

CN/EN-A01

Creator 4 金刚狼4系列

用户使用手册

USER GUIDE

中文P35

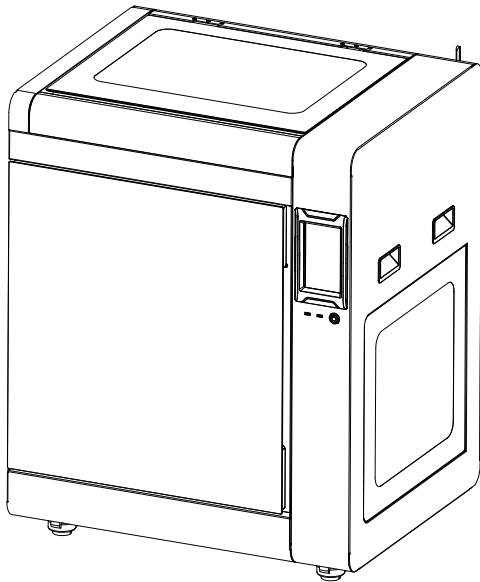

This guide is only applicable to FLASHFORGE Creator 4 3D printer

本手册仅适用于闪铸科技 金刚狼4 3D打印机

CONTENT

Notice	02
Equipment Parameter	05
1. Equipment Introduction	06
1.1 - Creator 4 Introduction	06
1.2 - Unpacking and Installation	07
1.3 - Packing List	09
2. Preparation Before Printing	11
2.1 - Filament Loading	11
2.2 - Equipment Calibration	12
2.3 - Internet Connection	13
2.3.1 - Wired Network Connection	13
2.3.2 - Wireless Network Connection	13
3. Software Installation	14
4. First Printing	14
4.1 - File Transfer: Wi-Fi Transfer	14
4.2 - Printing via USB Flash Drive	15
4.3 - Printing via FlashCloud	15
4.4 - Model Removal After Finishing Printing	15
5. Equipment Configuration and Operation	17
5.1 - Normal Mode	17
5.2 - Dual-extruder Printing Mode	17
5.3 - Mirror/Duplicate Mode	20
5.4 - Filament Configuration	21
5.5 - Filament Parameter Setting	22
5.6 - Removal Method of Water-soluble Support Material	23
5.7 - Camera Connection	23
6. Equipment Operation Interface Introduction	24
6.1 - Printing Screen	24
6.2 - Filament Screen	25
6.3 - Preheating Screen	26
6.4 - Tools Screen	26
6.5 - Setting Screen	27
7. Maintenance	28
7.1 - Maintenance Screen	28
7.2 - Extruder Maintenance Introduction	29
7.2.1 - Extruder Parts Diagram	29
7.2.2 - Clogged Nozzle Cleaning	29
7.2.3 - Platform Flatness Calibration	30
8. Q&A	32
9. Help and Support	34

NOTICE

Safety notice: Please strictly follow all the safety warnings and notices below all the time.

Note: Every 3D printer has undergone printing tests before leaving the factory. If there are some residues in the extruder of the equipment or some slight scratches on the build plate, it is normal and will not affect its use.

WORK ENVIRONMENT SAFETY

- ◆ Please keep the work table of the equipment clean and tidy.
- ◆ Please ensure that the equipment is away from combustible gases, liquids and dust when working. (The high temperature generated by the equipment operation may react with combustible gases, liquids, and airborne dust, thus causing fire)
- ◆ Children and untrained personnel are not allowed to operate the equipment alone.

ELECTRICAL SAFETY

- ◆ Be sure to ground the equipment. Do not modify the plug of the equipment. Ungrounded equipment/improperly grounded equipment/modified plug will inevitably increase the risk of electric leakage.
- ◆ Do not expose the equipment to damp or hot-sun environment. (Humidity will increase the risk of electric leakage.Exposure to sunlight will accelerate the aging of plastic parts)
- ◆ Make sure to only use the power cord provided by Flashforge.
- ◆ Do not use the equipment during an thunderstorm.
- ◆ Please shut down the equipment and unplug it if it is not in use for a long time.

PERSONAL SAFETY

- ◆ Do not touch the extruder and build plate, etc during printing.
- ◆ Do not touch the extruder and build plate when finishing printing in order to avoid high temperature burns or mechanical damage.
- ◆ Do not wear scarves, masks, gloves, jewelry ornaments or other objects that can easily get caught in the equipment when operating it.
- ◆ Do not operate the equipment while you are tired or under the influence of drugs, alcohol or medication.

CAUTIONS

- ◆ Keep the inside of the equipment clean and tidy. Do not drop metal objects into the slide chute at the bottom of the build plate.
- ◆ Please clean up the filament debris in time. It is recommended to operate this outside the equipment.
- ◆ Any modification of the equipment by yourself will result in that you will not be entitled to warranty rights anymore.
- ◆ Please keep the distance between the extruder and build plate for at least 50mm during filament loading operation. Too-close distance may cause clogged nozzle issue.
- ◆ Please operate the equipment in a well-ventilated environment.
- ◆ Do not use the equipment for illegal activities.
- ◆ Do not use the equipment to make any food storage products.
- ◆ Do not put the printed model into your mouth.

EQUIPMENT ENVIRONMENT REQUIREMENTS

- ◆ The room temperature should be between 15°C and 30°C.
- ◆ The humidity should be between 20RH% and 70RH%.

EQUIPMENT PLACEMENT REQUIREMENTS

- ◆ The equipment must be placed in a dry and ventilated environment. At least 30cm space must be reserved on the left side and rear side of the equipment, and at least 60cm space must be reserved on the right side and front side of the equipment. The storage temperature should be between 0°C and 40°C.

COMPATIBLE FILAMENT REQUIREMENTS

- ◆ When using the equipment, it is recommended to use Flashforge filaments. If non-Flashforge filaments are used, there will be certain differences in material characteristics, and thus printing parameters may need to be adjusted.

FILAMENT STORAGE REQUIREMENTS

- ◆ Please keep the storage environment of filaments dry and dust-free after unpacking. It is recommended to use the matching drying box for storage.

LEGAL STATEMENT

- ◆ The user has no right to make any modification to this user guide.
- ◆ Flashforge will not be responsible for any safety accidents caused by the disassembly or modification of the equipment by the customer. No one is allowed to modify or translate this guide without the permission of Flashforge. This guide is protected by copyright, and Flashforge reserves the right of the final interpretation of this guide.
- ◆ First Edition (August 2021)
@Copyright 2021 Zhejiang Flashforge 3D Technology Co., Ltd. All Rights Reserved.

Equipment Series

Creator 4F	Extruder F	Suitable for printing flexible filaments
Creator 4A	Extruder HT	Suitable for printing general/engineering filaments
Creator 4S	Extruder HT/Extruder HS	Suitable for printing composite filaments

Equipment Parameter

Build Volume	400*350*500mm
Layer Height	0.05mm-0.4mm
Printing Accuracy	±0.2mm or 0.002mm/mm (The larger values shall prevail.)
Printing Speed	10-200mm/s (it can be adjusted according to different materials and printing components)
Print Technology	FFF (Fused Filament Fabrication)
Maximum Platform Temperature	130°C
Maximum Chamber Temperature	65°C
Extruder	IDEX (Independent Dual Extruders)
Extruder Type	Direct Drive Extruder
Nozzle Diameter	0.4mm (default); 0.6/0.8mm (optional)
Maximum Extruder Temperature	F: 265°C; HT: 320°C; HS: 360°C
Supported Filament	TPU, PLA, PVA, PETG, TPU 98A, ABS, PP, PA, PC, PA12-CF, PET-CF
Filament Spool Capacity	1KG+2KG
Slicing Software	FlashPrint
Supported Format	Input: 3MF/STL/OBJ/FPP/BMP/PNG/JPG/JPEG; Output: GX/G
Connectivity	USB flash drive/Ethernet/Wi-Fi
Touch Screen	7-inch display screen with the resolution as 1024*600
Appropriate Temperature for Printing	15-30°C
Appropriate Humidity for Printing	20-70RH%
Power	2320W
Power Supply Input	AC 100-130V/200-240V; 50-60Hz
OCP (over-current protection)	30A
Net Weight	90kg
Printer Size	840X*675Y*1000Z(1050)mm
Installation Space Requirements	≥1400*1500*1600mm

1. Equipment Introduction

1.1 Creator 4 Introduction

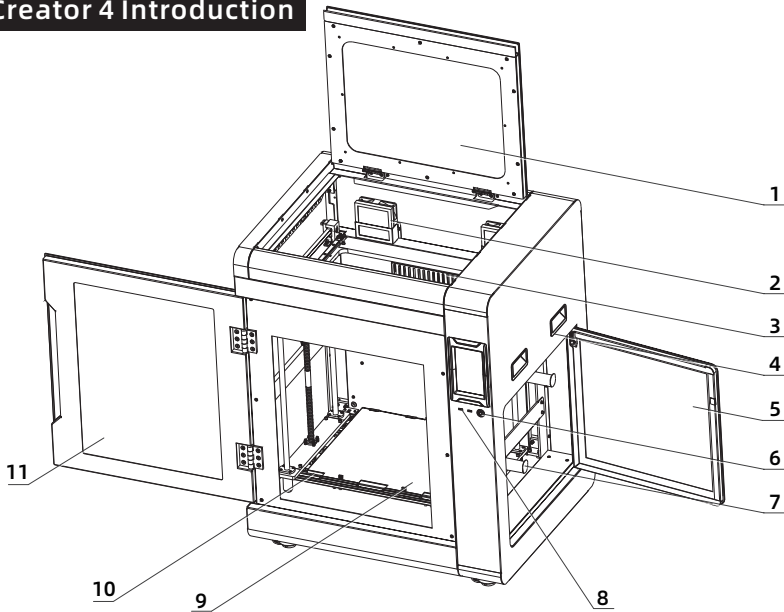

- 1. Upper Cover
- 2. Filter Fan
- 3. Inner Chamber Heating Assembly
- 4. Handle
- 5. Filament Door
- 6. Power Switch
- 7. Filament Spool Fixing Frame
- 8. USB Port
- 9. Flexible Steel Plate
- 10. Platform Plate
- 11. Front Door
- 12. Extruder
- 13. Camera
- 14. Ethernet Port
- 15. Power Port
- 16. LED Board

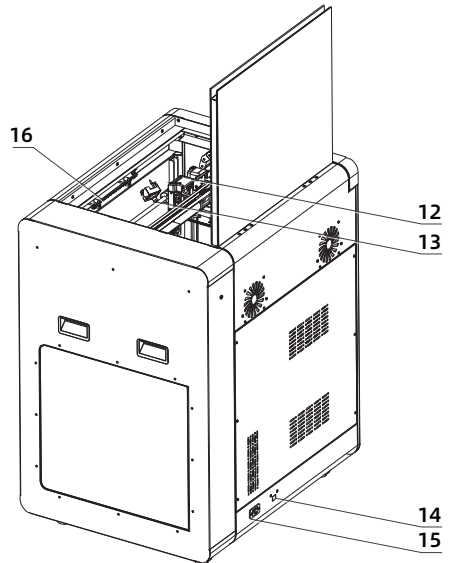

1.2 Unpacking and Installation



ATTENTION

- 1) To ensure the smooth transportation of the equipment, please use an automatic or manual forklift with appropriate specifications for handling.
- 2) Before unpacking, please make sure that the outer box of the equipment is intact.

Unpacking steps:

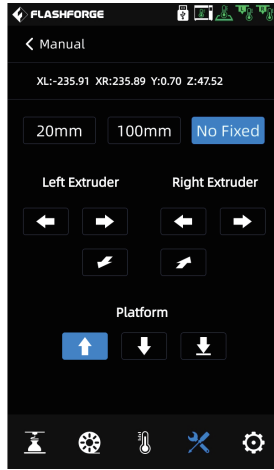
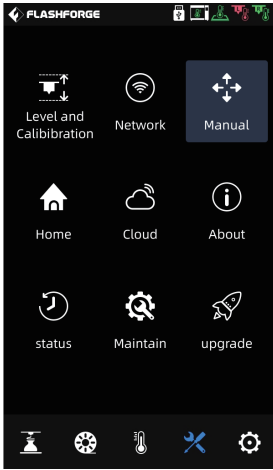
1. Use special tools to open the steel-edged wooden case;
2. Remove the steel-edged wooden case board and take off the protective foam;
3. Lift the equipment from the bottom of the wooden case;
4. Remove the protective wrapping film from the machine surface;
5. Open the front door of the machine and take out the power cord;
6. Connect the power cord to the socket and the equipment;
7. Touch the power switch slightly to start the machine;



8. Click the -[Manual] on the screen, select the "No Fixed", press and hold the  , the Z axis will rise to about 100 to 120mm, and then take out the inner pearl cotton;
9. Take out all pearl cotton and accessory boxes inside the equipment;
10. Use the accessory diagonal pliers to cut off the X-axis and Y-axis fixing ties (be careful not to cut off the ties of the filament guide tube and the extruder harness), and move the left and right extruders to ensure that they can move freely in X and Y directions;
11. Adjust the casters at the bottom of the equipment, make it rotate clockwise, and the foot pad will rise, so that the equipment can be pushed. Move the equipment to the position to be placed, and then adjust the casters counterclockwise to fix the equipment. At this time, the casters will not be able to rotate (when the equipment is installed, the installation space size should not be less than 1400*1500*1600mm);
12. Install the Wi-Fi antenna. Take out the Wi-Fi antenna from the accessory box, install it on the back of the equipment, and screw it tightly. The position is shown in the figure:

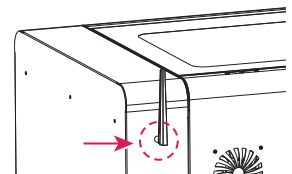

1.3 Packing List

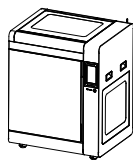

3D Printer



3D Printing Filament*2



Power Cord



After-sales Service Card



User Guide

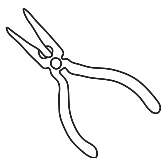

Nipper Pliers

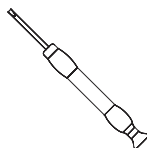

Straight Screwdriver

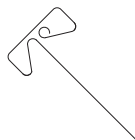

Unclogging Pin Tool



Allen Wrench

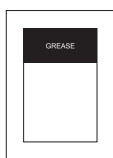

Lubricating Grease*2

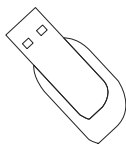

USB Flash Drive



Leveling Card

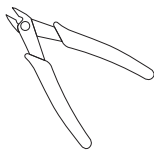

Diagonal Pliers

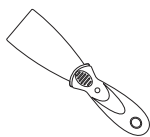

Scraper



Heat Insulating Gloves

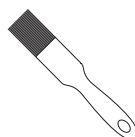

Cleaning Brush



Desiccant*2

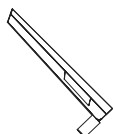

Wi-Fi Antenna

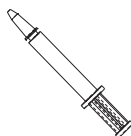

Thermally conductive adhesive*2

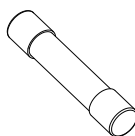

Fuse*5

Different equipment versions correspond to different equipment packaging configurations, with the following differences:

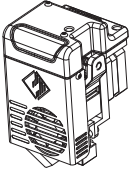
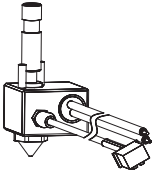
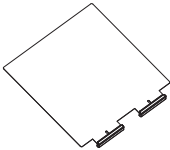
Equipment	Creator 4F	Creator 4A	Creator 4S
 <p>Extruder Assembly</p>	/	/	HT Extruder*2
 <p>Nozzle Assembly</p>	F Nozzle Assembly*2	HT Nozzle Assembly*2	HS Nozzle Assembly*2
 <p>Flexible Platform Steel Plate</p>	/	/	1

2.Preparation Before Printing

2.1 Filament Loading

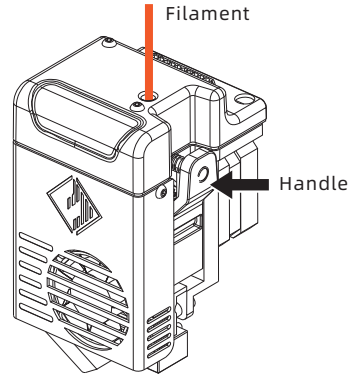
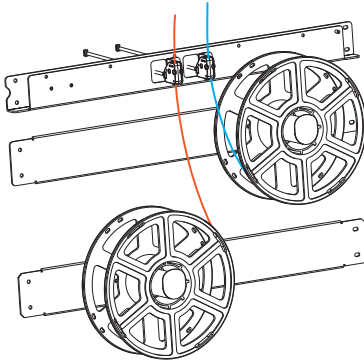

1. Open the door of the filament spool, hang the filament on the filament spool holder, and pass the filament through the corresponding filament sensors respectively until the filament is seen from the other end of the guide tube;

2. Press the filament feeding handle on the extruder to insert the filament into the extruder;

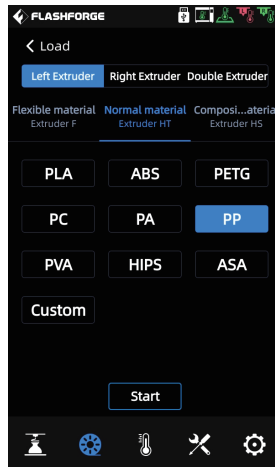
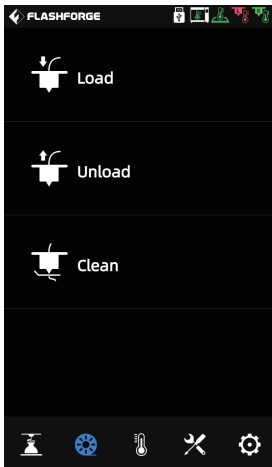

3. Click the  -[Load] on the screen, select the corresponding filament for each extruder, start filament feeding, and operate following the screen prompts.

2.2 Equipment Calibration

The equipment includes the following leveling and calibration operations:

Manual mode: Z-axis calibration, X,Y-axis calibration, expert mode calibration.

Auxiliary (Assist) mode: Sensor calibration, automatic leveling.



ATTENTION

Before the equipment leaves the factory, the extruder sensor calibration has been set, so it is unnecessary to operate again.

The equipment has been leveled and calibrated before leaving the factory, so it is generally unnecessary to calibrate again. However, the leveling plane may be damaged due to the vibration generated during transportation. It is recommended to perform a Z-axis calibration before printing.

Please proceed in the following order:

1. Click the  -[Level and Calibration] on the touch screen;
2. Select manual mode for Z-axis calibration;
3. Perform Z-axis calibration and operate following the screen prompts.

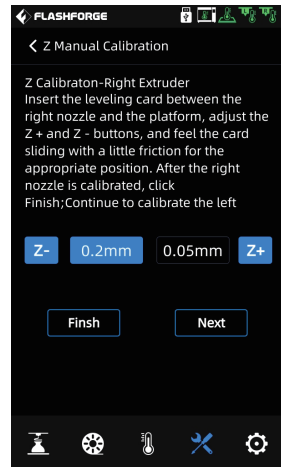
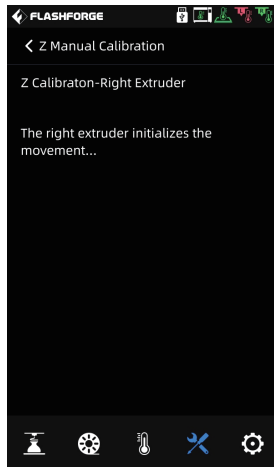
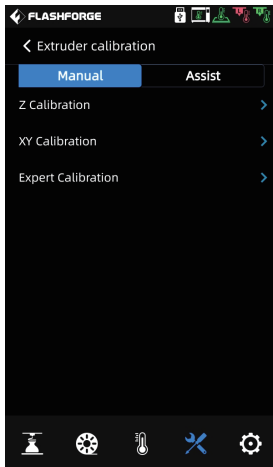

2.3 Internet Connection

2.3.1 Wired Network Connection

- 1) Plug the network cable into the network cable interface on the back of the equipment.
- 2) If the  icon appears in the upper right corner of the screen, it indicates that the equipment is successfully connected to the network.



2.3.2 Wireless Network Connection

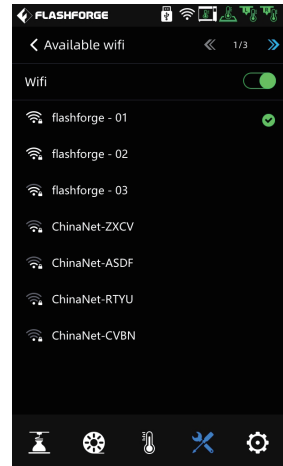
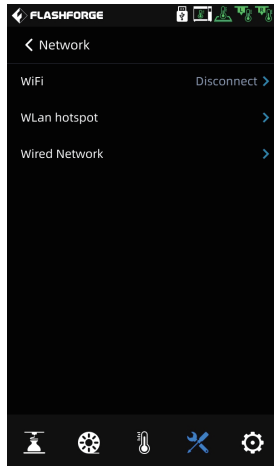
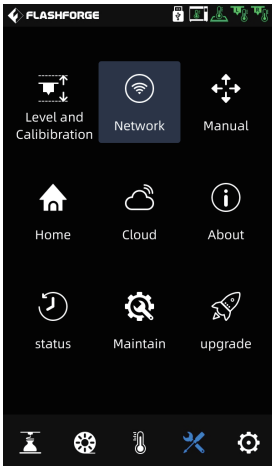

ATTENTION

Make sure Wi-Fi is installed before connecting to the wireless network, otherwise the wireless signal will be affected.



- 1) Click the  -[Network] on the touch screen, and select the "WiFi".
- 2) Click to connect to the corresponding wireless network. If the  icon appears in the upper right corner of the screen, it indicates that the equipment is successfully connected to the network.

3. Software Installation

Method 1: Find the FlashPrint software installation package in the USB flash drive and select the corresponding system version for installation.

Method 2: Download the latest slicing software from the official Chinese website (www.sz3dp.com) or the official English website (www.flashforge.com) for installation.

3D printing process:

Get the model file. - Slice it with the slicing software. - Transfer the file to the printer for printing.

4. First Printing

4.1 File Transfer: Wi-Fi Transfer

Import the file to FlashPrint for slicing, select the Creator 4 to connect to the machine (or by entering the IP address or by auto-scanning, while the IP address can be viewed in the [About] of the equipment). After slicing is completed, send the file directly to the printer for printing.

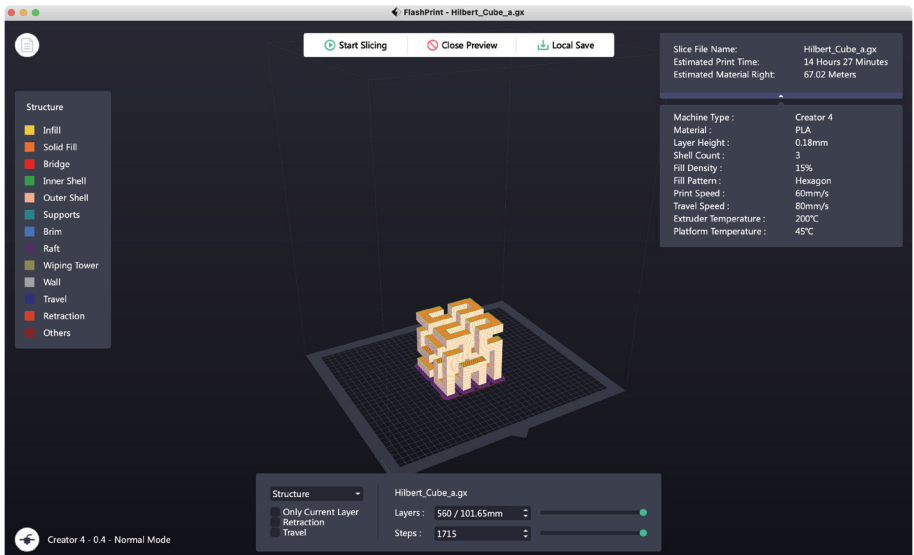

4.2 Printing via a USB Flash Drive

The equipment can perform printing via a USB flash drive: save the sliced file to the USB flash drive, insert the USB flash drive into the equipment, and select the corresponding file to print.

4.3 Printing via FlashCloud

Printing via FlashCloud

1. Enter the FlashCloud website, register your account, and then you can log in and use it after the email activation.

FlashCloud: <https://cloud.sz3dp.com>

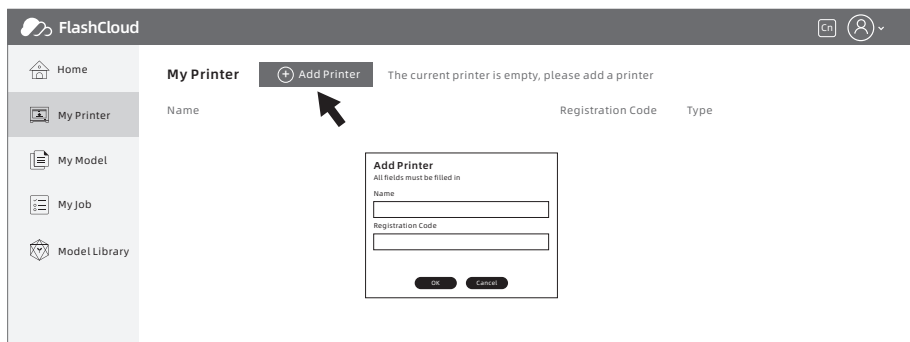

2. Click the [My Printer]-[Add Printer].

Fill in the registration number (cloud registration code) on the "Add Printer" page, and name the printer. After clicking the "OK", these information will appear in the FlashCloud interface of the printer.

4.4 Model Removal After Finishing Printing

Warning

- When removing the model from the build plate, please pay attention to the need to wait for the platform to cool down before operating. At this time, you can check the temperature icon on the status bar of the screen to confirm the platform temperature. The green icon indicates that the platform temperature is lower than 50°C, then you can operate it safely.
- The matching gloves can be used when removing the model, and attention must be paid to the high temperature of the equipment.

After finishing printing, lift the lock latch on the front of the platform plate upwards and rotate it 90 degrees, take out the whole platform plate, and bend the platform plate to remove the model.

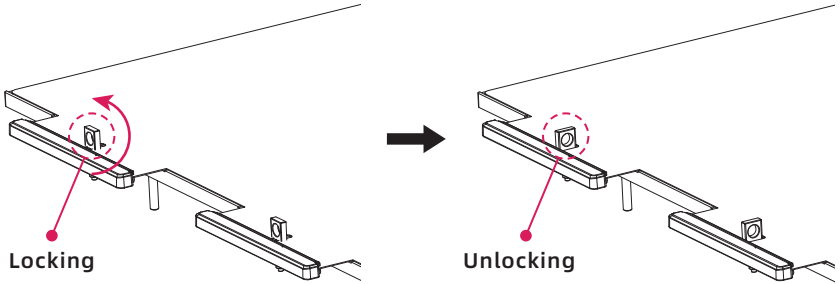

Remove the model and put the platform plate back into the equipment again. Operate as follows:

1. Install the flexible steel plate on the platform plate with the four snap hooks inserted at the rear end (note that they should be inserted on the inside of the snap hooks);
2. Rotate the lock latch 90 degrees and press the flexible steel plate.

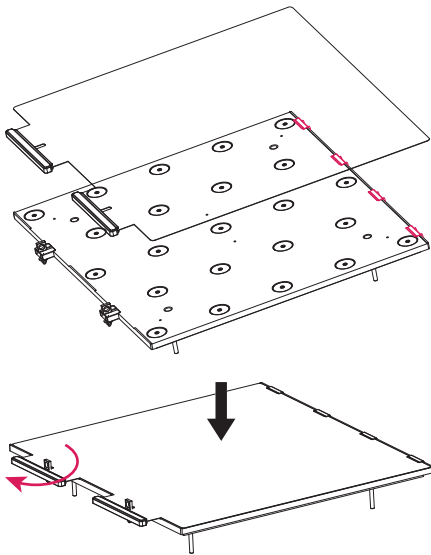

5.Equipment Configuration and Operation

5.1 Normal Mode

When the equipment uses a single extruder to print, set in the normal mode in the slicing software; The right extruder printing model is preferred by default. Users can also select suitable extruders to print according to actual needs. The model can be modified by moving, rotating and scaling. Click the [Start Slicing], select the corresponding printing material, and click the [Slice] and the sliced file can be generated.

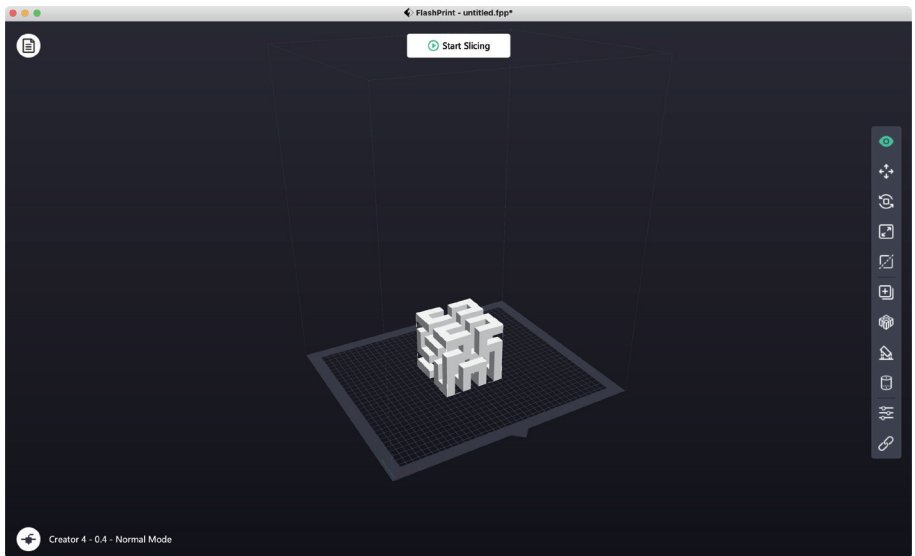

5.2 Dual-extruder Printing Mode

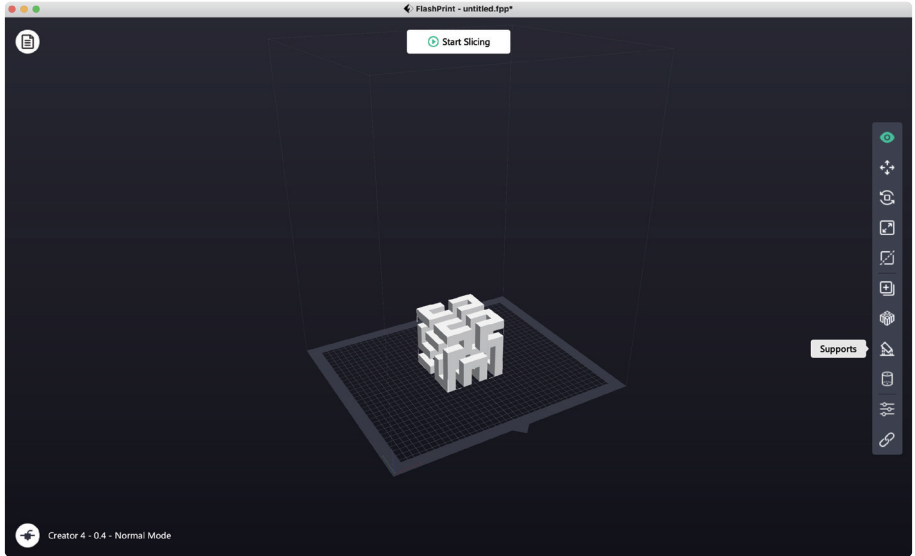

When printing dual-color/dual-filament models in the dual-extruder printing mode, please make sure that the nozzles are in contact with the anti-oozing plate, which will prevent the nozzles from oozing during the printing process; When printing single-color models, a single extruder is automatically used as the printing extruder by default if the user has not set the dual-extruder printing mode in advance.

The following settings can be made when printing dual-color / dual-filament models:

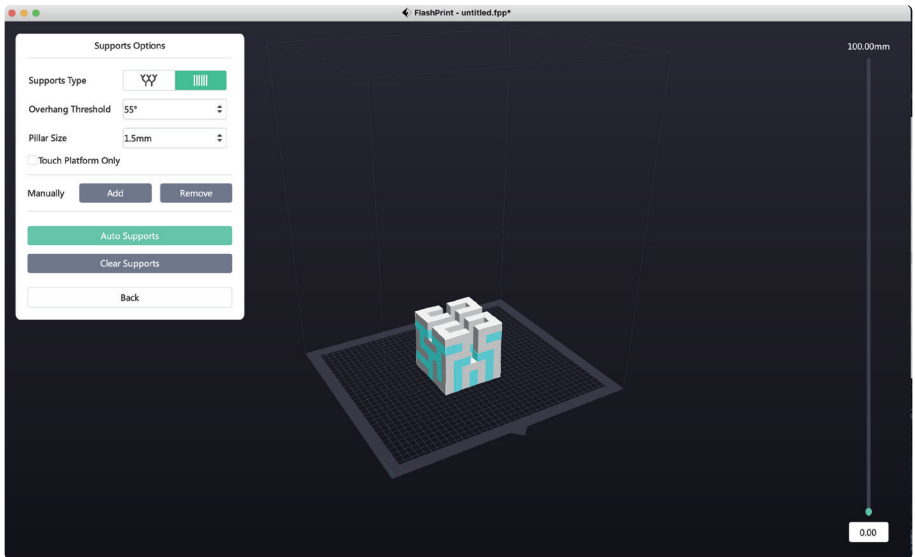

1. Load the model;



- 2. Click the  icon and select the support type as  ;
- 3. Click the [Auto Supports];

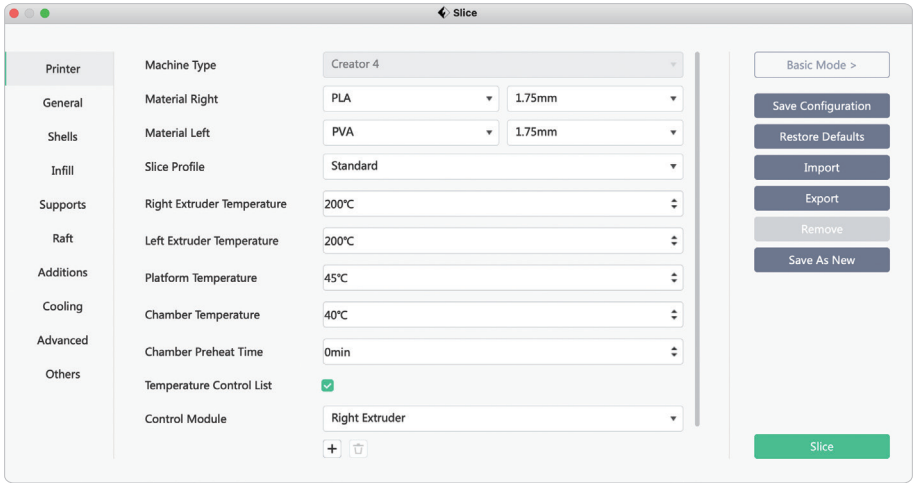

4. Click the [Start Slicing] to enter the parameter configuration screen;
5. Select the configured filaments (for example, Creator 4 PLA+PVA);
6. Click the [Slice].

⚠ ATTENTION

By default, the equipment prints the support and model with the same extruder. If different filaments are used for support (such as printing PVA support with the left extruder and printing PLA model with the right extruder), select the left extruder in the support options.

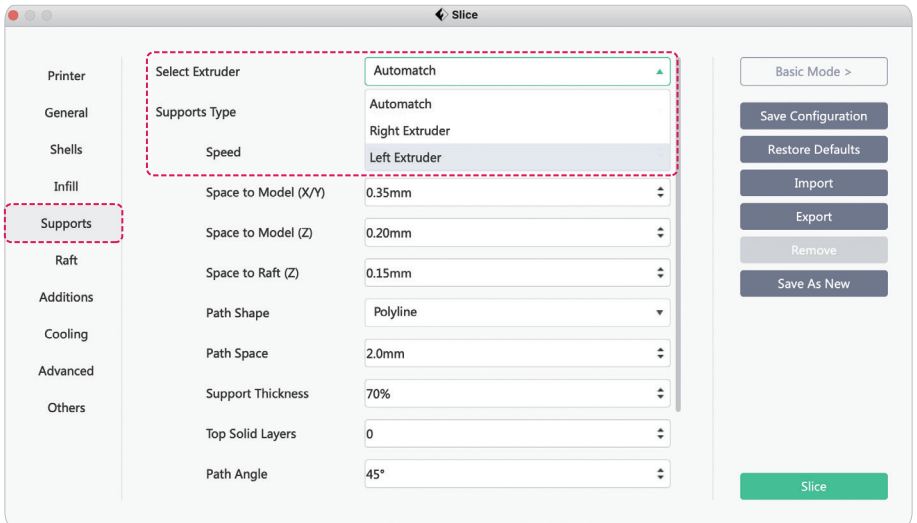

5.3 Mirror/Duplicate Mode

When you need to print two identical or mirrored models, just choose the mirror/duplicate mode in the slicing software. In this mode, the left and right extruders will print the models at the same time (**Note: only models with X-axis less than 183mm are supported in the mirror/duplicate mode**).

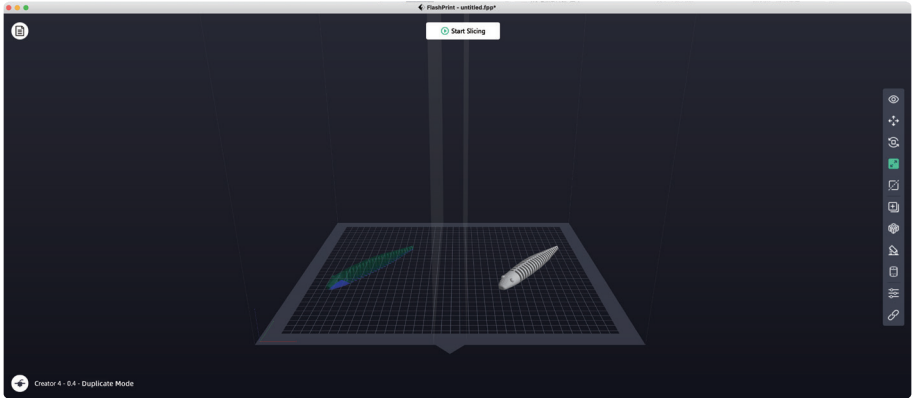

Compensation layer in the mirror/duplicate mode

Mirror/duplicate mode: Since the heights of the left and right extruders are different after installation, the software will automatically add a compensation layer to compensate for the height difference when slicing, so that the printing heights of the left and right sides are consistent. Z-axis calibration is based on the right extruder, and the height difference between the left and right extruders is recorded.

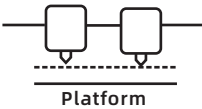

When the distance between the right extruder and the platform is smaller, the left extruder prints the compensation layer.

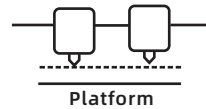

When the distance between the left extruder and the platform is smaller, the right extruder prints the compensation layer.

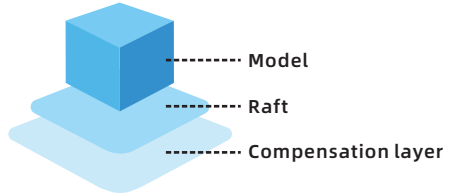

When the height difference is less than 0.2mm, the compensation layer will not be printed.

The compensation layer is printed first, and it is easy to be removed by adhering to the raft. If the raft printing is not added, the compensation layer will be directly applied to the model, which is difficult to remove.

5.4 Filament Configuration

Creator 4 series is equipped with two independent extruders;
 Creator 4 series contains three types of extruders, which can support different filaments separately.



Extruder-F
 180-265°C
 2.85mm



Extruder-HT
 200-320°C
 1.75mm



Extruder-HS
 265-360°C
 1.75mm

Different types of equipment are equipped with different types of extruders:

Creator 4F	Creator 4A	Creator 4S
Extruder-F	Extruder-HT	Extruder-HT/Extruder-HS
Suitable for printing flexible filaments	Suitable for printing engineering filaments	Suitable for printing composite filaments
TPU85A-95A	PLA/ABS/ASA/PETG/PC, etc.	PACF/PAGF/PET-CF, etc.

Please refer to the table below for the combination of independent dual-extruder extrusion filaments.

Soluble filament combination:

Left extruder	Right extruder
PVA	PLA
PVA	NYLON
HIPS	ABS
HIPS	ASA
HIPS	PC
HIPS	PETG
HIPS	HIPS

PVA: Soluble in water.

HIPS: Soluble in limonene.

Insoluble filament combination:

Left extruder	Right extruder
PLA	PLA
ABS	ABS
ASA	ASA
PC	PC
PA	PA
PETG	PETG
PA-CF	PA-CF
PA-GF	PA-GF

⚠ ATTENTION

As carbon fiber or glass fiber material is with strong strength, please use extruder-HS for printing this kind of material. The extruder is configured with a 0.6mm-nozzle by default; Carbon fiber composite materials are easy to cause blockage, so it is not recommended to use a 0.4mm-nozzle for printing this.

Storage of filaments such as PVA/PA/PACF

- As PVA is water-soluble and highly water-absorbent, and filaments will soften after absorbing water, it will easily cause printing failure. During printing, it is necessary to place desiccant in the filament bin, and it is recommended to keep the humidity of the filament bin within 15%; Humidity status can be viewed on the screen.
- PVA will soften when the temperature is higher than 50°C, so it is not recommended to dehumidify it during the chamber-heating state when printing PVA.
- PA/PVA/PACF all need to be stored in a sealed and dry environment. After finishing printing, it is recommended to store the filaments in a drying box.
- Filaments are easy to cause stringing and oozing when being exposed to moisture, which will cause poor printing quality of models.

5.5 Filament Parameter Setting

In order to obtain high-quality printing effect, different printing filaments require different parameter settings, and Flashforge will configure the corresponding printing parameters in the slicing software. If filaments of other brands are used, the characteristics of the filaments corresponding to different filament brands will be different, which may involve fine adjustment of parameters. You can use the expert mode to adjust different parameters when slicing. The following are some adjustment suggestions for reference only:

- Thickening the height of the first layer and increasing the filament extrusion amount of the first layer are beneficial to the adhesion of the first layer.
- When printing small models with PLA (or the printing environment temperature is lower than 25°C), it is recommended to set the raft temperature to 40°C.
- When printing large models with PLA (or the printing environment temperature is lower than 10°C), it is recommended to set the raft temperature to 50°C.
- Make sure to close the equipment door and front door when printing models with ABS.
- When printing partial and small models, different printing speeds can be set in the slicing software according to the layer height.
- If you need to strengthen the partial part of the model, different filling amounts can be set according to the layer height.
- If the model is required to feature strong performance, it is recommended to select 100% filling.
- If the support is easy to break, it is recommended that the thickness of the support should be more than 90%.
- If the support is difficult to remove, it is recommended to increase the Z-axis clearance of the support.
- If you need to improve printing efficiency, you can increase the layer thickness.

5.6 Removal Method of Water-soluble Support Material

Models using PVA as the support material require some subsequent treatment after finishing printing. Place the models in water to dissolve the PVA support.

1. Submerge the model in water

Place the model with PVA support in water and the PVA will slowly dissolve. This process can be quickened by using the following methods:

- Warm water will decrease the dissolving time. If PLA is used for the printed model, please ensure that the water is no hotter than 35 °C, otherwise the PLA may be deformed.
- Use stirring/running water to decrease the dissolving time. Moving water enables the PVA to dissolve more quickly.
- You can also speed up PVA dissolution by placing the model in water for approximately 10 minutes, then removing most of the support with pliers and placing the model back in the water.

2. Rinse with water

After PVA supports are totally dissolved, rinse the model with water to remove any excess PVA.

3. Let the model dry

Let the model dry completely and apply additional post-processing to the model if necessary.

4. Disposal of waste water

As PVA is a biodegradable material, therefore disposing the waste water afterwards is easy. The waste water can be disposed down the drain. After disposal, run hot water from the tap for approximately 30 seconds to remove any excess saturated PVA and to avoid longer-term clogging issues.

5.7 Camera Connection

1. Please remove the camera cover before using the camera;
2. Turn on the camera switch;
3. After the equipment is connected to FlashPrint, the real-time video screen can be viewed in the FlashPrint-[Multi-Machine Control].

6. Equipment Operation Interface Introduction

ATTENTION The firmware will be upgraded from time to time. Please refer to the actual display screen for the interface. The following is only a brief introduction of functions.

6.1 Printing Screen

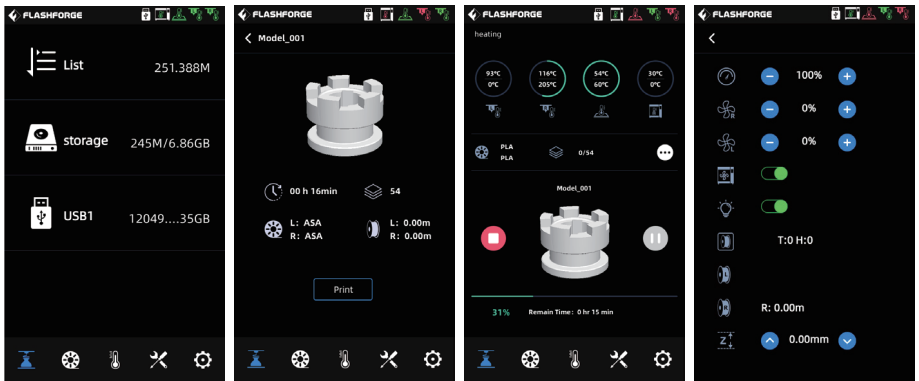

Some parameters can be adjusted during printing. Click the  icon for the control of the printing speed, fans and lights.

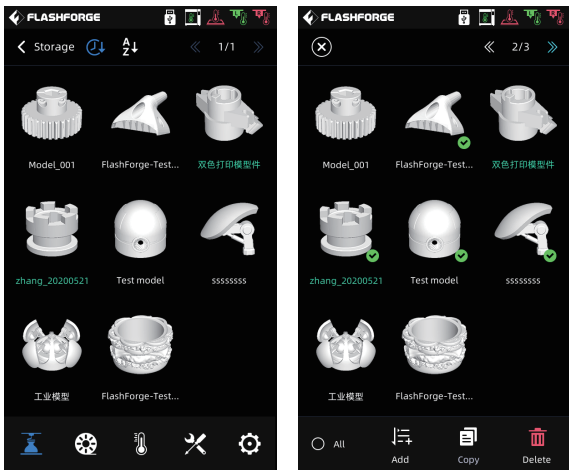

After finishing printing a file, if the color of the file name in the list changes, it means that the file has been printed; If you want to delete a file in memory, please long press the file in the file list, and then select it and click the [Delete].

6.2 Filament Screen

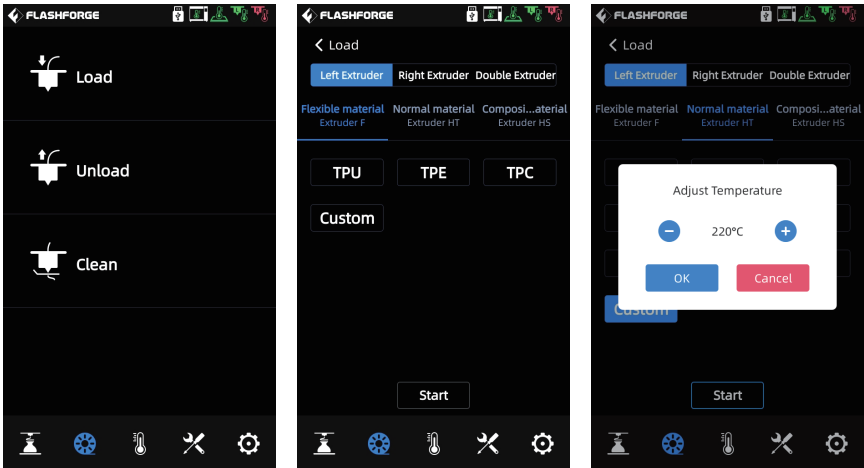

The filament screen includes: [Load], [Unload] and [Clean].

- During filament feeding and withdrawing, users can set according to the filament to be actually installed. If the currently required filament is not in the screen, users can customize the filament and set the required temperature for filament feeding.
- Filament cleaning: When the filaments printed in the last two times are different, please perform filament cleaning. In this way, it will avoid the situation that the filament is carbonized thus causing blockage or is not extruded due to different melting temperatures of the filaments. When switching from a high-temperature filament to a low-temperature filament, this operation must be performed; For example, when you need to switch it to PLA material after printing with PC material, it is necessary to clean the PC material from the nozzle, so it is necessary to set the temperature required for melting the PC material until all the PC material is extruded from the nozzle and there is no residue left in the nozzle.

6.3 Preheating Screen

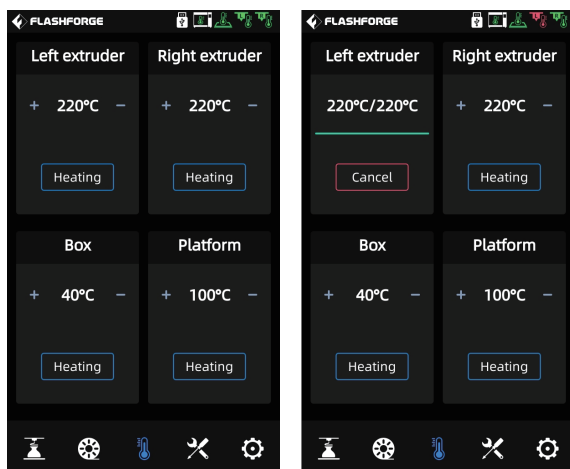

The temperature of the extruder, chamber and platform can be set in advance as required on the preheating screen.

6.4 Tools Screen

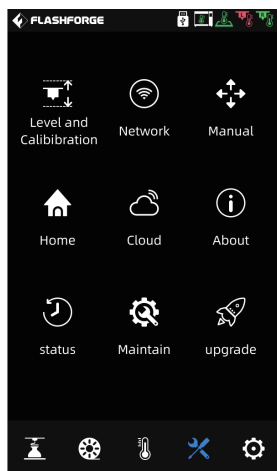

The tools screen includes:

[Level and Calibration]:

[Manual] (Manual calibration): Z-axis calibration, X,Y-axis calibration, expert mode calibration.

[Assist] (Auxiliary calibration): extruder sensor calibration, automatic leveling.

[Network]: Here you can connect the wireless network, wired network and hot spot.

[Manual] (Manual control): Here you can manually move the X,Y,Z axis of the equipment.

[Home]: Here you can make each axis of the equipment return to the zero position.

[Cloud]: Here you can connect to the FlashCloud.

[About]: Here displays the basic information about the equipment.

[status]: Here displays the running status of the equipment.

[Maintain] (Maintenance): Here lists some maintenance items. If users encounter any problems, you can check here.

[upgrade]: Here is for the firmware upgrade. You can upgrade to the latest firmware of the equipment when the wireless network is connected.

6.5 Setting Screen

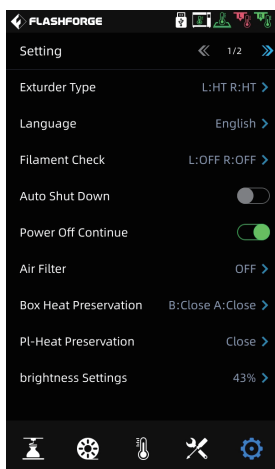

The functions can be turned on or off on the setting screen.

- [Extruder Type]: The selection of the extruder type is related to the setting of the filament feeding and printing temperature, so be sure to select the extruder that matches the equipment installation.
- [Filament Check]: When the filament detection function is turned on, the equipment will stop printing when the filament runs out in the middle of printing.
- [Auto Shut Down]: When the automatic shutdown function is turned on, the equipment will automatically shut down after finishing the model printing.
- [Power Off Continue]: When the resuming printing after recovering from power failure function is turned on, if the power is suddenly off during printing, the equipment will automatically store the current printing position data, and continue the printing of the current model after the power supply is recovered.
- [Air Filter]: When the air filtration function is turned on, the fan on the back of the equipment starts; The front of the fan is equipped with HEPA filter cotton and activated carbon filter cotton, which can filter the dust and peculiar smell produced during printing.
- [Box Heat Preservation]: When the chamber insulation function is turned on, the temperature insulation time before and after printing can be set. Due to the characteristics of some materials, it is necessary to maintain the thermal balance before and after printing.
- [PI-Heat Preservation]: When the platform insulation function is turned on, the platform insulation time before and after printing can be set. When in the transition state of removing the model, avoid increasing the time of reheating when the temperature drops. When this function is turned on, the platform remains the heating state when the model is removed after printing. Please pay attention to the high temperature and avoid burns.

7.Maintenance

7.1 Maintenance Screen

You can query the current encountered problem on the maintenance screen.

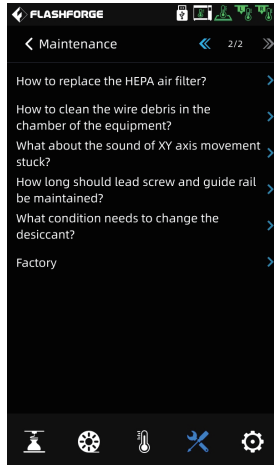
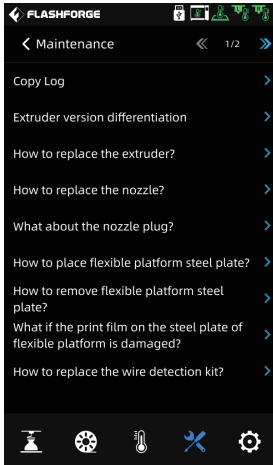

7.2 Extruder Maintenance Introduction

7.2.1 Extruder Parts Diagram



ATTENTION

When operating the extruder, the power supply must be disconnected.

Left Extruder Assembly

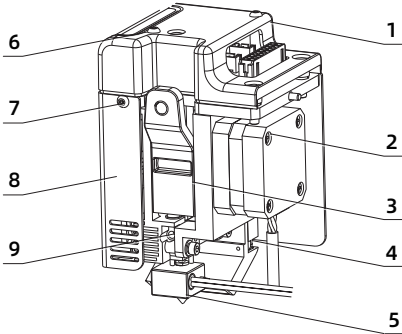

Right Extruder Assembly

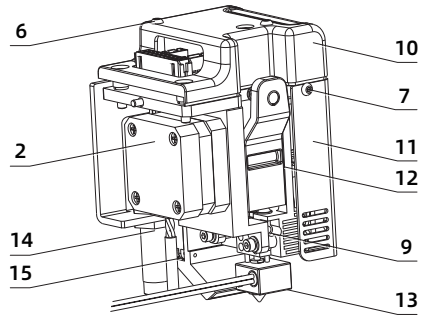

- | | |
|---|--------------------------------------|
| 1. Left Extruder Upper Cover | 9. M4*3 Screw |
| 2. Filament Feed Motor | 10. Right Extruder Upper Cover |
| 3. Left Handle | 11. Right Extruder Sheet Metal Shell |
| 4. Cooling Fan | 12. Right Handle |
| 5. Left Nozzle Assembly | 13. Right Nozzle Assembly |
| 6. M3*30 Hexagon Socket Button Head Screw M3*30 | 14. Proximity Sensor |
| 7. M3*6 Hexagon Socket Button Head Screw M3*6 | 15. Cooling Fan |
| 8. Left Extruder Sheet Metal Shell | |

As shown in the above figure, the device is equipped with two extruders. According to the direction, they are called the left extruder and the right extruder. The parts and numbers related to the extruder assembly are consistent, but they are left-right symmetric. Please note that they cannot be used interchangeably at will.

7.2.2 Clogged Nozzle Cleaning

Method 1:

1. Heat the nozzle to the matching temperature of the filament used;
2. Pull out the filament guide tube, press the handle and pull out the filament;
3. Observe whether the head of the filament is bent. If so, cut off the bent part of the head of the filament, then insert the filament guide tube and the filament into the nozzle again, and click the [Load], and the nozzle will re-extrude the filament.

Method 2:

Heat the nozzle and insert the unclogging pin tool into the throat and the nozzle to extrude the filament inside the nozzle.

Method 3:

If the method 1 and method 2 operations are ineffective, please replace the nozzle assembly. Click the [Maintain (Maintenance)]-[How to replace the nozzle?], and operate following the instructions on the screen. That is, as follows:

⚠ ATTENTION After checking the steps shown on the screen, power off the equipment before replacing the nozzle assembly.

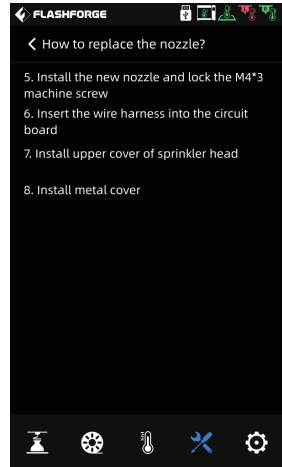
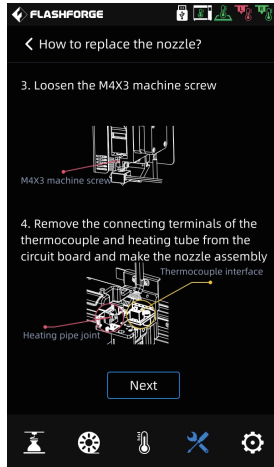
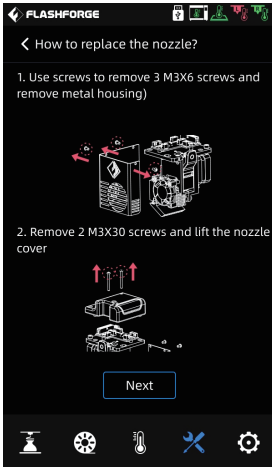

7.2.3 Platform Flatness Calibration

Generally, users do not need to operate this. When the flatness of the equipment that has undergone some calibration or the automatic leveling compensation is still incorrect, it may be that the flatness of the platform has been damaged during installation. At this time, the initial platform leveling is required.

♥ Special note For this operation, you can contact Flashforge after-sales personnel for remote assistance in the calibration.

Please operate as follows: There are 4 leveling points in total.

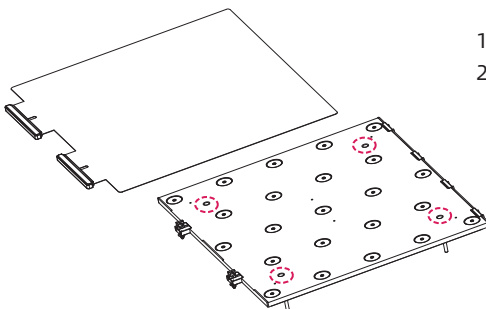

1. Remove the flexible steel plate;
2. Loosen (note that the screws only need to be loosened, and do not need to be removed) the four locking screws on the platform;

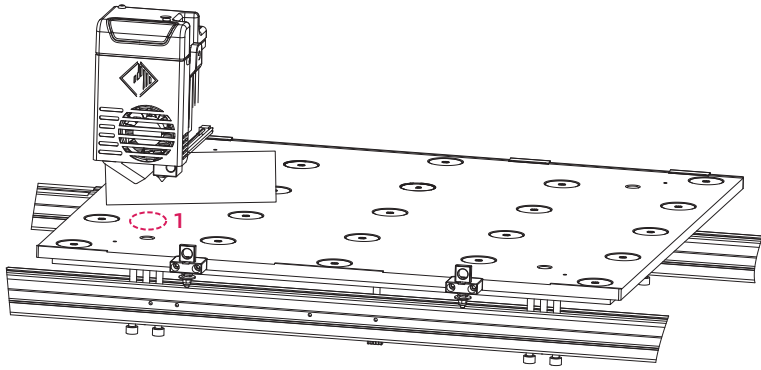

3. Click the  -[Manual] on the screen and click the Z-axis rising arrow to manually move the extruder to the Position 1 (that is, above the leveling screw); Stop when the Z axis rises to the position where it will touch the nozzle; Insert the leveling card between the platform plate and nozzle, and adjust M5*60 left screw under the profile at the same time; When feeling resistance during sliding the leveling card, it indicates that it is the appropriate position. Then adjust the right screw under the profile in the same way as the left screw;

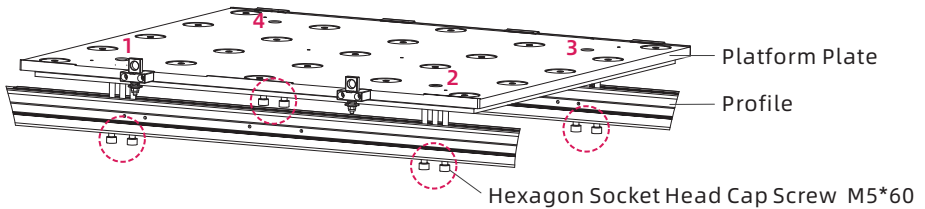

4. Move the extruder to the Position 2 manually, and be sure to move it slowly. If the extruder scratches the platform, it is necessary to adjust the M5*60 left screw under the profile at the Position 2, slide the leveling card to confirm that the distance between the nozzle and the platform is appropriate, and then adjust the right screw;
5. Adjust the Position 3 and Position 4 in the same operation method in turn;
6. After finishing the adjustment of the four positions, please tighten the four screws above the platform to lock the platform.

8.Q&A

Q1. Clogged nozzle issue.

Answer: Click the  -[Maintain (Maintenance)].

Q2. How to replace the nozzle?



Please shut down and cut off the power before replacing the nozzle. Please do not operate with electricity.

Answer: Click the  -[Maintain (Maintenance)].

Q3. Is there a need to calibrate the extruder after replacing the nozzle?

Answer: No.

Q4. Click to start printing the model, and the extruder moves, but there is no filament extrusion at the beginning of printing.

Answer:

1. Observe the filament guide tube to confirm whether the filament enters the extruder; If not, please click the [Load] button again until the filament is extruded from the extruder;
2. Check whether the nozzle is clogged. If so, please check the Q1 for the solution.

Q5. The relative position between the nozzle and the platform is too high (far away from the platform) or too low (touching the platform) during printing. How to level it?

Answer: Click the  -[Level and Calibration]-Z calibration, and operate according to the screen prompts.

Q6. Can the filaments of other brands be used?

Answer: The filaments of other brands can be used. But it needs parameter adjustment and configuration due to the temperature difference of different filaments.

Q7. Is the equipment compatible with all AC inputs?

Answer: The equipment is compatible with 220V-240V or 100-120VAC input voltage. If the input voltage is different between different regions, it cannot be directly powered on, that is, for countries with 110VAC voltage, it needs to purchase the equipment corresponding to 110VAC voltage.

Q8. Can the equipment automatically shut down after finishing printing?

Answer: Yes.

Q9. Is printing ABS material safe?

Answer: ABS material will release toxic gases during heating, so it is recommended to open the HEPA air filter for filtration during or after printing. If conditions permit, it is recommended to place the equipment in an open environment for printing. It is recommended to print PLA nontoxic materials in children's activity places.

Q10. The printed model is warping or not sticking well.

- Scheme 1: Increasing the platform temperature can effectively alleviate this problem, as the high temperature can increase the adhesion between the platform and the model.
- Scheme 2: Choosing to add a raft when slicing the model can effectively alleviate this problem.
- Scheme 3: Apply glue.
- Scheme 4: If the clearance between the nozzle and platform is too large, the clearance can be reduced accordingly, and the clearance can be adjusted by using extruder calibration in the expert mode or leveling and calibration function.
- Scheme 5: Confirm whether the platform is laid flat. The leveling and calibration function can be used, and it is recommended to perform a full-process automatic leveling.

Q11. Must a raft be added when printing a model?

Answer: Not necessary. When printing the raft, the filament extrusion amount is larger and the printing success rate is higher. Under the condition of raft heating, the adhesion between the model and the platform plate increases, which makes the model adhere to the platform well when printing, and also increases the printing success rate.

Q12. After inserting the USB flash drive, the print file can not be found, and the screen displays all as folders.

Answer: The format of the U disk is incorrect. The equipment supports FAT32 file system. Please format the U disk into FAT32 format.

Q13. What is the expert mode during calibration?

Answer: When in the expert mode, the clearance value can be directly adjusted and a whole calibration process can be skipped. The expert mode is suitable for experienced users. For details, please refer to the expert mode explanation in the screen calibration instructions.

Q14. Wi-Fi connection failure.

Answer:

1. Please check whether the Wi-Fi name contains special characters. If so, please modify it and try again.
2. Please check whether the password contains special characters. If so, please modify it and try again.

Q15. Matters needing attention in updating the firmware.

Answer: Please do not disconnect the power and the network when downloading or updating the firmware to prevent the update failure.

Q16. Why is the boot screen white?

Answer: If the start-up sound can be heard, please replace the screen or the flat cable; If not, please contact our after-sales personnel.

Q17. Equipment crash and black screen (blank screen) occur during printing.

Answer: Please reboot the equipment, copy the firmware log and send it to Flashforge after-sales engineers for troubleshooting.

9.Help and Support

Flashforge professional after-sales service personnel and salesmen are on standby for you at any time, and are very willing to help you solve any problems you encountered during use. If the answer can not be found from the user guide, you can go to our official website to search for the solution of your problem, or contact us by phone.

Some explanations and solutions of common problems can be found in our official website. Many of your problems can be solved in www.flashforge.com, the official English website of Flashforge.

The Flashforge after-sales team can be reached by email or phone from 8:00 a.m. to 5:00 p.m. from Monday to Saturday to solve your problems. In case you contact us during off-duty time, your inquiry will be answered the next following business day immediately. We are sorry for any inconvenience caused.

Note: Due to the replacement of different filaments, there will be a small amount of impurities left in the extruder, which will cause the clogged nozzle issue. As this can be solved by just unclogging it, this is not a quality problem. If users encounter this problem when using the equipment, please contact our after-sales personnel, and complete the unclogging operation under the guidance of our after-sales personnel.

After-sales Service Tel: +86-400-886-6023

E-mail: support@flashforge.com

Address: No. 518, Xianyuan Road, Wucheng District, Jinhua City, Zhejiang Province, China

Note: Please provide the product serial number which is the barcode at the back of the printer before contacting our after-sales personnel.



S/N: FFAD*****

目录

注意事项	36
设备参数	38
第一章 设备简介	39
1.1 - 整机介绍	39
1.2 - 开箱和安装	40
1.3 - 装箱清单	41
第二章 打印前准备	43
2.1 - 安装丝料	43
2.2 - 校准设备	44
2.3 - 网络连接	45
2.3.1 - 有线网络连接	45
2.3.2 - 无线网络连接	45
第三章 软件安装	46
第四章 首次打印	46
4.1 - 文件传输：Wi-Fi传输	46
4.2 - U盘打印	47
4.3 - 云打印	47
4.4 - 打印完成移除模型	48
第五章 设备的配置与操作	49
5.1 - 普通模式	49
5.2 - 设置双喷头打印模式	49
5.3 - 镜像/复制模式	52
5.4 - 材料配置	53
5.5 - 材料参数设置	54
5.6 - 水溶性支撑材料的去除方式	54
5.7 - 摄像头连接查看	55
第六章 设备操控界面简介	56
6.1 - 打印界面	56
6.2 - 丝料界面	57
6.3 - 预热界面	58
6.4 - 工具界面	58
6.5 - 设置界面	59
第七章 维护	60
7.1 - 维护界面	60
7.2 - 喷头维护详细介绍	61
7.2.1 - 喷头零件图示	61
7.2.2 - 喷嘴堵头清理	61
7.2.3 - 平台平面度校准	62
第八章 Q&A	64
第九章 帮助与支持	66

注意事项

安全提示：请确保认真阅读以下安全提示

注意：每台3D打印机在出厂前都经过打印测试，若设备喷头存在耗材残留或打印平台有轻微划痕，均属正常现象，不影响使用。

工作环境安全

- ◆ 请确保设备的工作台面干净整洁。
- ◆ 请确保设备工作时远离可燃性气体、液体及灰尘。设备运行产生的高温有可能会与可燃性气体、液体及空气中的粉尘发生反应从而引发火灾。
- ◆ 儿童及未经培训的人员请勿单独操作设备。

用电操作安全

- ◆ 请务必将设备接地，切勿改装设备的插头。未接地/未正确接地/改装插头必然会增加漏电风险。
- ◆ 请勿将设备暴露在潮湿或暴晒的环境中：潮湿的环境会增加漏电的风险，暴晒会加速设备的塑件老化。
- ◆ 请勿滥用电源线，务必使用闪铸科技提供的电源线。
- ◆ 切勿在雷雨天气使用设备。
- ◆ 如长时间不使用设备，请关闭设备并拔下电源线插头。

个人操作安全

- ◆ 在设备打印时，请勿触碰喷头、平台等位置。
- ◆ 在打印完成时，请勿触碰喷头与平台，以免高温烫伤或机械损伤。
- ◆ 在操作设备时，请勿穿戴围巾、口罩、手套、珠宝首饰等容易卷入设备的物件。
- ◆ 请勿在饮酒、服药之后操作设备。

设备使用提示

- ◆ 保持设备内部整洁，切勿将金属物体掉入打印平台底部的滑槽内。
- ◆ 请及时清理丝料碎屑，建议在设备外进行操作。
- ◆ 自行对设备进行任何改装将不再享有保修权利。
- ◆ 在设备进丝操作时，请将喷头和平台至少保持50mm的距离。距离过近可能会造成喷头堵塞。
- ◆ 请在通风的环境下操作设备。
- ◆ 请勿利用该设备进行违法犯罪活动。
- ◆ 请勿利用该设备制作食物储存类产品。
- ◆ 请勿将打印模型放入口腔。

设备运行环境要求

- ◆ 室内温度在15-30°C为宜；湿度在20-70RH%为宜。

设备放置要求

- ◆ 设备需要被放置于干燥通风的环境中。设备左侧和后侧必须预留至少30cm的空间距离，右侧和前侧必须预留至少60cm的空间距离。存储温度在0-40°C为宜。

设备兼容耗材要求

- ◆ 在使用该设备时，建议使用闪铸科技的耗材。如使用非闪铸科技的耗材，材料特性有一定差异，打印参数可能需要调整。

耗材存储要求

- ◆ 耗材拆封后请保持耗材的储存环境干燥及无尘，建议使用配套干燥盒存储。

法律申明

- ◆ 用户无权对此使用手册进行任何修改。
- ◆ 客户若自行拆装或改造设备造成任何安全事故，闪铸科技概不负责。未经闪铸科技允许，任何人不得对该手册进行修改或翻译。本手册受版权保护，闪铸科技对本手册保留最终解释权。
- ◆ 第一版（2021年8月）
@Copyright 2021浙江闪铸三维科技有限公司 版权所有

设备系列

金刚狼4F	金刚狼4A	金刚狼4S
喷头-F	喷头-HT	喷头-HT/喷头-HS
适合打印柔性耗材	适合打印常规/工程耗材	适合打印复合耗材

设备参数

成型尺寸	400*350*500mm
打印层厚	0.05mm-0.4mm
打印精度	±0.2mm或0.002mm/mm（以较大值为准）
打印速度	10-200mm/s（随材料与打印构件不同而调整）
成型原理	FFF（Fused Filament Fabrication）熔丝制造技术
平台最高温度	130℃
腔体最高温度	65℃
喷头	独立双喷头
喷头类型	近程送丝喷头
喷嘴口径	0.4mm（默认）；0.6/0.8mm（可选）
最高喷头温度	F：265℃；HT：320℃；HS：360℃
支持耗材类型	TPU, PLA, PVA, PETG, TPU 98A, ABS, PP, PA, PC, PA12-CF, PET-CF
耗材仓容量	1KG+2KG
匹配软件	FlashPrint
导入/导出格式	导入：3MF/STL/OBJ/FPP/BMP/PNG/JPG/JPEG；导出：GX/G
通讯	U盘/以太网/无线网
触控屏	7英寸显示屏幕，分辨率为1024*600
打印适宜温度	15-30℃
打印适宜湿度	20-70RH%
打印机功率	2320W
电源参数	AC 100-130V/200-240V；50-60Hz
过电流保护	30A
设备净重	90kg
设备尺寸	840X*675Y*1000Z(1050)mm
装机空间要求	≥1400*1500*1600mm

第一章 设备简介

1.1 整机介绍

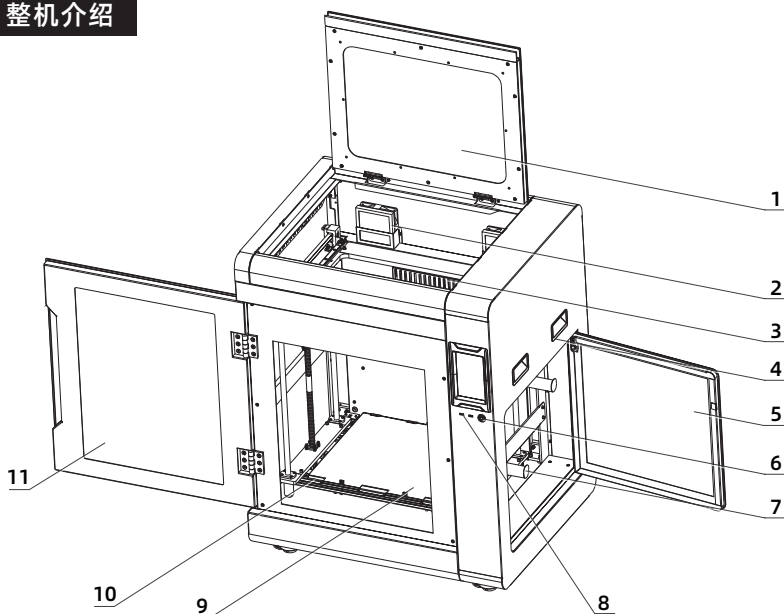

1. 上盖
2. 过滤风扇
3. 内腔加热组件
4. 机器抬手
5. 丝料窗门
6. 开关按钮
7. 丝料盘固定架
8. USB接口
9. 柔性钢板
10. 平台板
11. 前门
12. 喷头
13. 摄像头
14. 网口
15. 电源接口
16. LED灯板

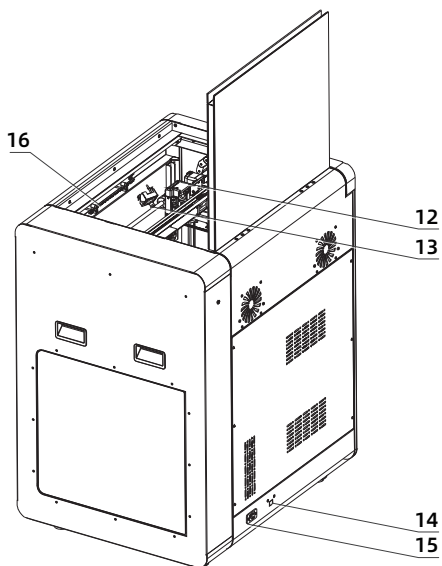

1.2 开箱和安装



⚠ 注意事项

- ① 为确保设备运输平稳，请选用合适规格的自动或手动叉车进行搬运。
- ② 拆箱前，请确认设备外箱完好无损。

拆箱步骤：

1. 使用专用工具打开钢边木箱；
2. 移除钢边木箱板，取下保护泡沫；
3. 将设备从木箱底托上抬下；
4. 去除机器表面保护缠绕膜；
5. 打开机器前门，取出电源线；
6. 将电源线连接插座与设备；
7. 轻触开关按钮，启动机器；



8. 点击屏幕  -【手动控制】，选择无固定值量程，长按 ，Z轴将会上升，大概上升到100-120mm处，取出内部珍珠棉；
9. 取出设备内部所有的珍珠棉以及配件盒；
10. 使用配件斜口钳，剪断X、Y轴固定扎带（注意请勿剪断导丝管与喷头线束的扎带），移动左右喷头，确保在X、Y方向可以自由移动；
11. 调节设备底部的福马轮，顺时针旋转，脚垫上升，设备可以被推动。将设备移动到要放置的位置，再逆时针调节福马轮，可固定设备，此时轮子将无法旋转（设备安装时，安装空间尺寸不小于：1400*1500*1600mm）；

12. 安装Wi-Fi天线。从配件盒中取出Wi-Fi天线，将其安装到设备背部位置，旋紧即可。如图所示位置：

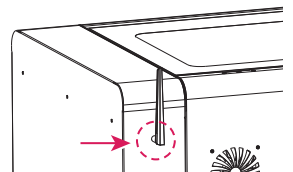

1.3 装箱清单

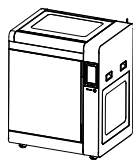

3D打印机



3D打印耗材*2

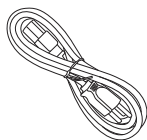

电源线



售后服务卡



说明书

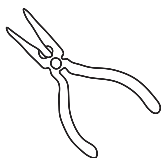

尖嘴钳

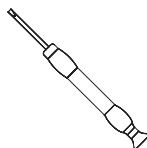

一字螺丝刀

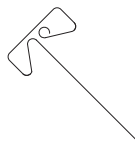

通针



内六角扳手套装

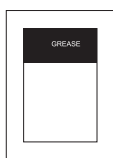

润滑脂*2

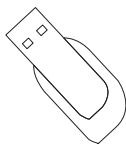

U盘

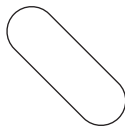

调平卡

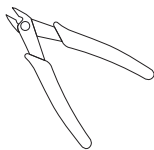

斜口钳

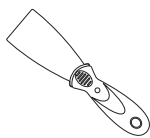

铲刀



隔热手套

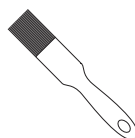

清理刷



干燥剂*2

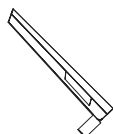

Wi-Fi天线

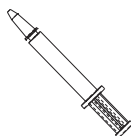

导热胶*2

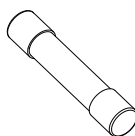

保险丝*5

不同设备版本对应设备包装配置不同，区别如下：

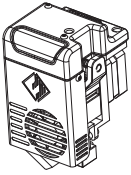
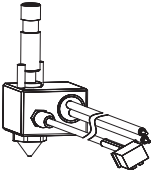
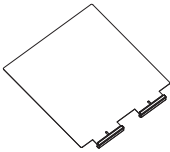
设备	金刚狼4F	金刚狼4A	金刚狼4S
 <p>喷头组件</p>	无	无	HT整体喷头*2
 <p>喷嘴组件</p>	F喷嘴组件*2	HT喷嘴组件*2	HS喷嘴组件*2
 <p>柔性平台钢板</p>	无	无	1

第二章 打印前准备

2.1 安装丝料

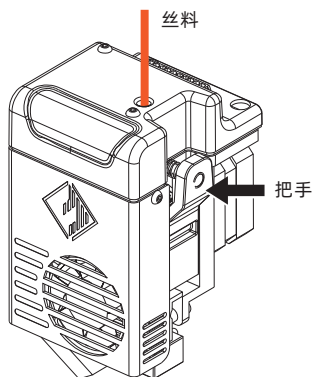
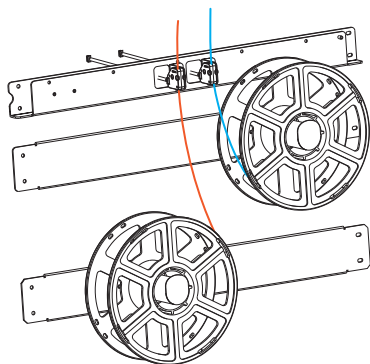

1. 打开丝料仓门，将丝料挂到丝料架，将丝料分别穿过对应的丝料传感器，直至从导丝管另一端看到丝料；

2. 按下喷头上的进丝把手，将丝料插入到喷头内部；



3. 点击屏幕【丝料】-【进丝】，选择各喷头对应材料，开始进丝，按屏幕提示操作。

2.2 校准设备

设备包含如下调平校准操作：

手动模式：Z轴校准，XY轴校准，专家模式

辅助模式：传感器校准，自动调平

⚠ 注意事项 设备在出厂前，喷头传感器校准已经设定完毕，无需再次操作。

设备在出厂前进行过调平校准，一般无需再次校准。但由于运输震动关系，调平面可能被破坏，建议在使用前进行一次Z轴校准。

请按如下顺序进行操作：

1. 在触控屏上点击【工具】-【调平-校准】；
2. 选择手动模式进行Z轴校准；
3. 进行Z轴校准，按屏幕提示进行操作。



2.3 网络连接

2.3.1 有线网络连接

- ① 将网线插到设备背部的网线接口。
- ② 若屏幕右上角出现  图标，则表明设备已经成功连接网络。

2.3.2 无线网络连接

⚠ 注意事项 连接无线网络前，请确保已安装Wi-Fi，否则无线信号将被影响。

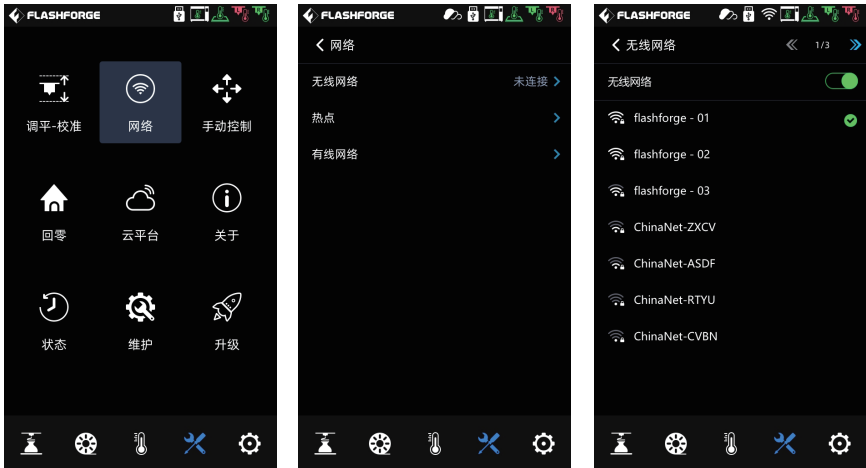

- ① 点击屏幕【工具】-【网络】，选择无线网络。
- ② 点击连接对应无线网络，若屏幕右上角出现  图标，则表明设备已经成功连接网络。

第三章 软件安装

方法一：在U盘中找到FlashPrint软件安装包，选择对应的系统版本进行安装。

方法二：从中文官方网站www.sz3dp.com下载最新的切片软件。

3D 打印过程：

获取模型文件 - 使用切片软件进行切片 - 文件传输至打印机打印。

第四章 首次打印

4.1 文件传输：Wi-Fi传输

将文件导入FlashPrint进行切片，选择金刚狼4设备关联机器（还可通过输入IP地址或自动扫描的方式，IP地址可在设备【关于】中查看）。切片完成后直接发送文件至打印机即可打印。

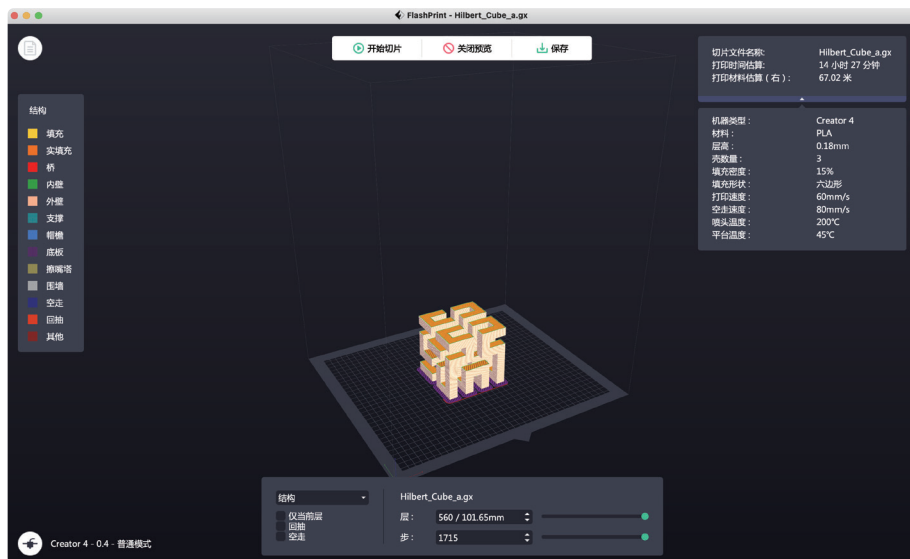

4.2 U盘打印

设备也可通过U盘打印。将切片好的文件保存至U盘，将U盘插入设备，选择对应文件即可打印。

4.3 云打印

闪铸云打印

1. 打开闪铸云网站，注册账号，经过邮箱激活后，即可登录使用。

闪铸云：<https://cloud.sz3dp.com>



2. 点击【我的打印机】- 【添加打印机】。

在添加打印机页面填写注册号（云注册码），为打印机起个名字，点击确定后，这些信息会出现在打印机的闪铸云界面。

4.4 打印完成移除模型

警告

- 从打印平台上移除模型时，请注意需要等待平台冷却后再操作。此时可查看屏幕状态栏温度图标来确认平台温度，绿色图标表示平台温度低于 50°C ，可进行安全操作。
- 移除模型时可以使用配套手套，同时务必注意设备高温。

打印完成后，将平台板前部锁扣向上提拉旋转90度，取出整个平台板，将平台板折弯即可取下模型。

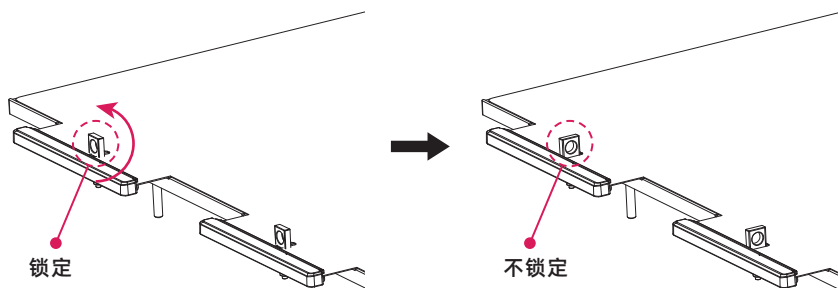

取下模型重新将平台板放回设备，操作如下：

1. 将柔性钢板安装到平台板上，后端插入四个弹扣（注意是插入弹扣的内侧）；
2. 旋转锁扣90度，压住柔性钢板。

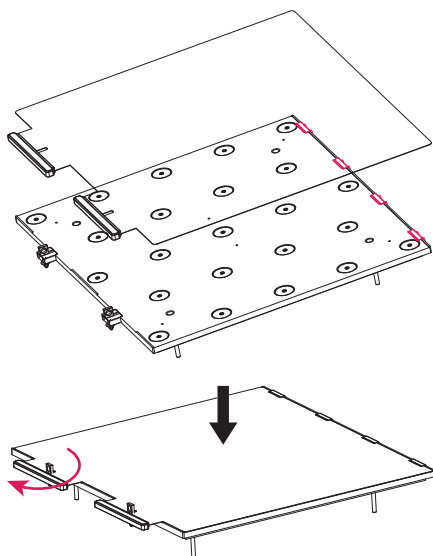

第五章 设备的配置与操作

5.1 普通模式

设备使用单喷头打印时，在切片软件中设置普通模式即可；软件默认首选右喷头打印模型。用户也可根据实际需要，选择合适的喷头打印。模型可进行移动、旋转、缩放等修改；点击【开始切片】，选择对应的打印材料，点击【切片】后生成切片文件。

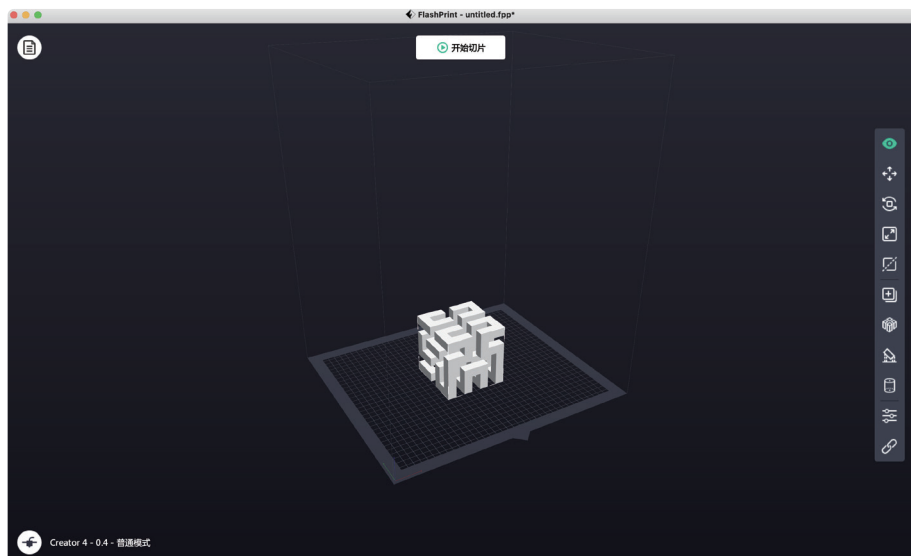

5.2 设置双喷头打印模式

若使用双喷头打印模式打印双色/双材料模型时，请确保喷嘴接触防溢丝板，这可以避免喷嘴在打印过程中溢料；

当打印单色模型时，若用户未提前进行双喷头打印模式设置，则默认进行单喷头打印。

打印双色或者双材料模型时可进行如下设置：

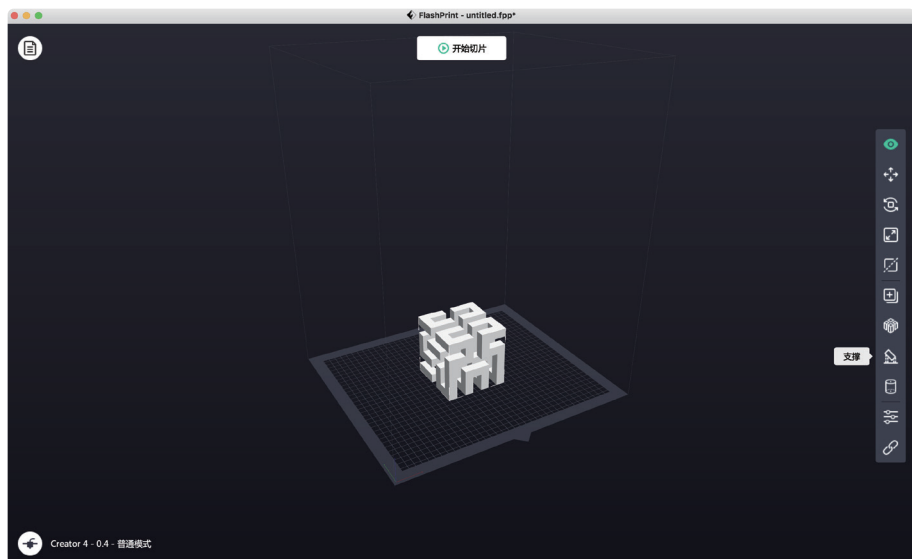

1. 载入模型；

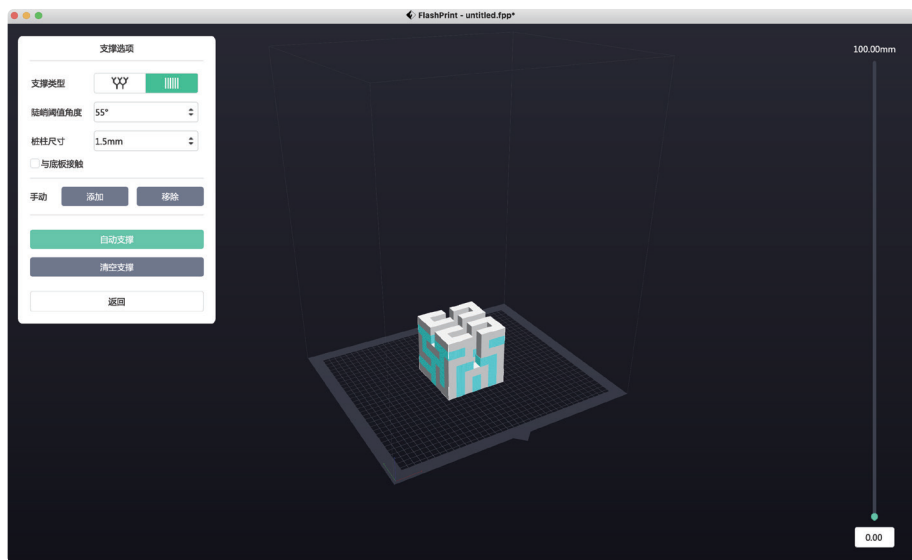

2. 点击【支撑】图标，选择支撑类型为【线性支撑】；

3. 点击【自动支撑】；

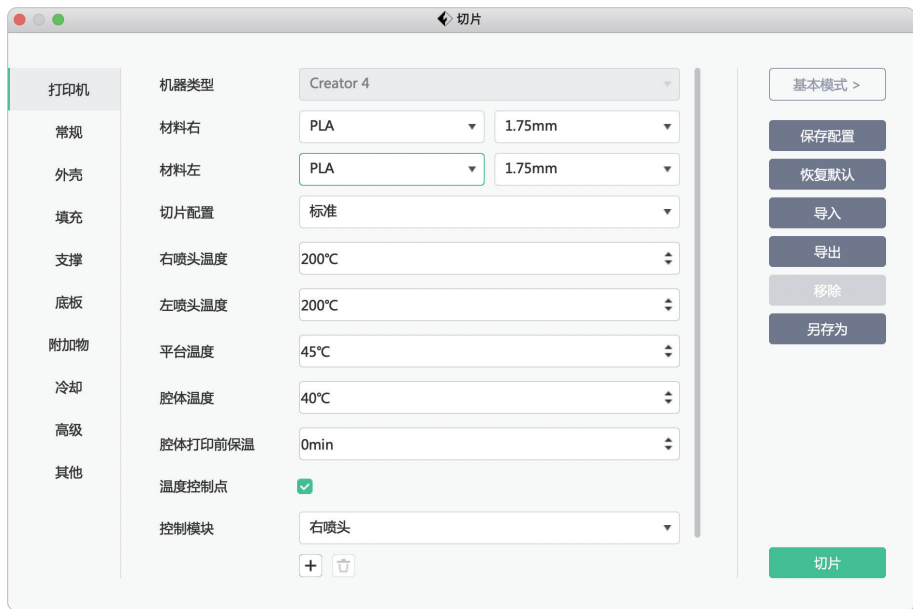

4. 点击【开始切片】，进入参数配置页面；
5. 选择配置材料（如Creator 4 PLA+PVA）；
6. 点击【切片】。



注意事项

设备默认同一喷头打印支撑及模型。若采用不同耗材支撑（如使用左喷头打印PVA支撑，使用右喷头打印PLA模型），则在支撑选项中选择左喷头。



5.3 镜像/复制模式

当需要打印两个相同或者镜像的模型时，可以在切片软件中选择镜像/复制模式。在此模式下，左右喷头将同时打印模型。（注意：镜像/复制模式下，仅支持X轴小于183mm的模型）

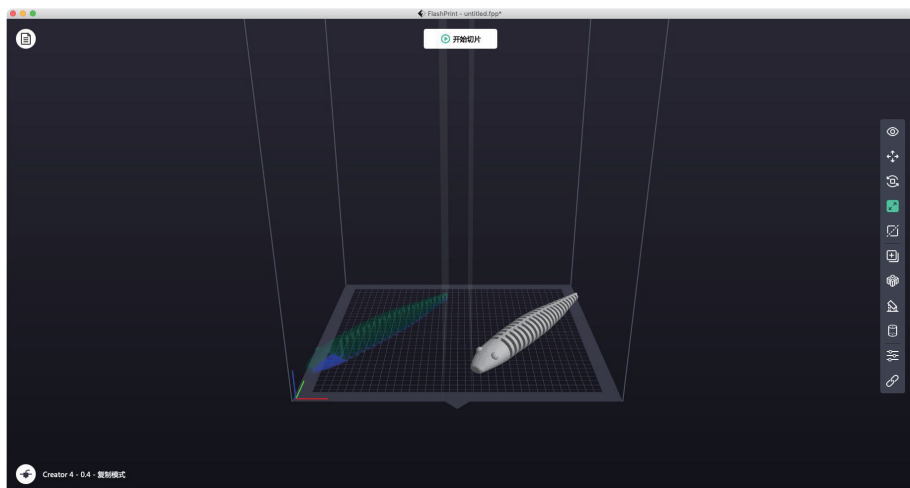

关于镜像/复制模式中的补偿层

镜像/复制模式：由于左右喷头安装后高度不相同，因此切片时软件会自动增加补偿层以补偿高度的差距，从而保证左右两边的打印高度一致。Z轴校准时以右喷头为基准，记录左右喷头的高度差。

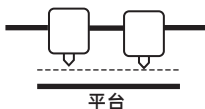

右喷头与平台距离小，左喷头打印补偿层。

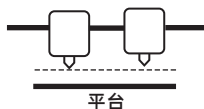

左喷头与平台距离小，右喷头打印补偿层。

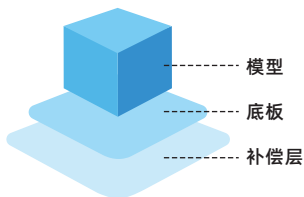

高度差小于0.2mm时，补偿层不打印。

补偿层最先打印，与底板粘附在一起容易拆除。若不增加底板打印，补偿层直接作用于模型底板，较难拆除。

5.4 材料配置

金刚狼4系列配置两个独立喷头；

金刚狼4系列包含3个型号的喷头，可分别支持不同的材料。



喷头-F
180-265°C
2.85mm



喷头-HT
200-320°C
1.75mm



喷头-HS
265-360°C
1.75mm

不同设备型号配置不同类型喷头：

金刚狼4F	金刚狼4A	金刚狼4S
喷头-F	喷头-HT	喷头-HT/喷头-HS
柔性耗材打印	工程材料打印	复合材料打印
TPU85A-95A	PLA/ABS/ASA/PETG/PC等	PACF/PAGF/PET-CF等

独立双头挤出材料可组合情况，请参见下表：

可溶性耗材组合：

左喷头	右喷头
PVA	PLA
PVA	NYLON
HIPS	ABS
HIPS	ASA
HIPS	PC
HIPS	PETG
HIPS	HIPS

PVA: 可溶解于水

HIPS: 可溶解于柠檬烯

非可溶性耗材组合：

左喷头	右喷头
PLA	PLA
ABS	ABS
ASA	ASA
PC	PC
PA	PA
PETG	PETG
PA-CF	PA-CF
PA-GF	PA-GF



注意事项

碳纤维或玻璃纤维材料强度较强，打印该类材料时请使用喷头-HS，该喷头默认配置0.6mm喷嘴；碳纤维复合材料容易堵头，不建议使用0.4mm喷嘴进行打印。

PVA/PA/PACF等耗材的存储

- 由于PVA是水溶性的，吸水性较强，耗材吸水后软化，容易造成打印失败。打印时需要在耗材舱放置干燥剂，同时建议将耗材舱湿度保持在15%以内；湿度状态可通过屏幕查看。
- PVA在温度高于50°C时会软化，因此不建议打印PVA时在加热舱温进行除湿。
- PA/PVA/PACF都需要在密封干燥的环境中存储。打印完成后，建议将耗材放入干燥盒中存储。
- 耗材受潮容易拉丝，会造成模型打印质量不佳。

5.5 材料参数设置

为获得优质打印效果，不同的打印耗材需要不同的参数设置，闪铸科技会在切片软件中配置相应的打印参数。若使用其他品牌的耗材，不同耗材品牌对应材料的特性会有差异，可能涉及参数微调。切片时可以使用专家模式对不同参数进行调整，以下是部分调整建议，仅供参考：

- 第一层层高加厚，加大第一层出丝量有利于第一层的粘附。
- 打印PLA小模型（或打印环境温度低于25°C）时建议设置底板温度为40°C。
- 打印PLA大模型（或打印环境温度低于10°C）时建议设置底板温度为50°C。
- 打印ABS模型时务必关闭设备的舱门以及前门。
- 打印局部细小模型时可以根据层高在切片软件中设置不同的打印速度。
- 若需要加强模型局部，可以根据层高度设置不同的填充量。
- 若需要模型具有较强性能，建议选择100%填充。
- 若支撑易断裂，建议设置支撑厚度为90%以上。
- 若支撑较难去除，建议加大支撑的Z轴间隙。
- 若需提升打印效率，可加大层厚设置。

5.6 水溶性支撑材料的去除方式

使用PVA为支撑材料的模型在打印完成后需要进行后续处理，将模型放置于水中可溶解PVA支撑。

1. 将模型浸泡于水中

将带有PVA支撑的模型放入水中，让PVA缓慢溶解来去除支撑。用户可以利用以下几种方法加快溶解过程：

- 使用热水可以减少溶解的时间。如果打印模型的材料是PLA，请确保水的最高温度不超过35°C，以免PLA变形。
- 搅拌/流动的水可大大减少溶解时间。当水流动时，PVA溶解得更快。
- 先将模型在水中浸泡约10分钟，拿出后用钳子去除大部分的支撑，再把模型放回水中，让PVA更容易溶解。

2. 用水冲洗

在PVA支撑完全溶解后，用水冲洗模型以去除剩余的PVA支撑。

3. 晾干模型

让模型完全干燥，如有必要再对模型进行额外的后处理。

4. 废水处理

由于PVA可生物降解，因此事后很容易处置废水，废水可通过废水管道排出。废水处理完毕后，用热水冲洗水管约30秒，以去除排水管中多余的PVA，避免长期堵塞。后续处理时使用的水可以重复用于浸泡多个模型，不过可能会增加溶解时间。因此建议使用新水以达到最快速效果。

5.7 摄像头连接查看

1. 使用摄像头前，请取下摄像头盖子；
2. 打开摄像头开关；
3. 设备与FlashPrint连接后可以在FlashPrint - 【多机控制】中查看到实时视频画面。

第六章 设备操控界面简介



注意事项

固件会不定期升级，界面请以实际显示页面为准，以下仅为功能简介。

6.1 打印界面

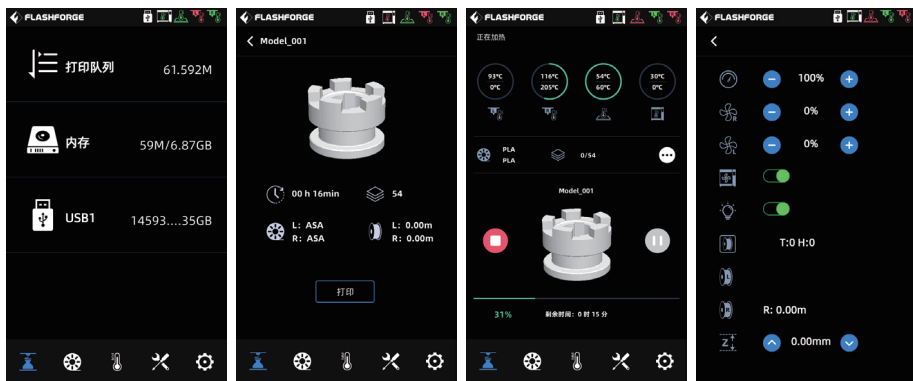

打印时可进行部分参数调整。

点击  图标可进行打印速度，风扇，灯的控制。

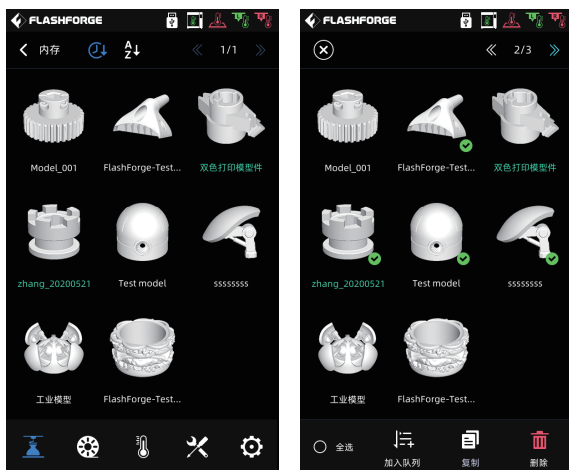

打印文件完成后，若列表中文件颜色发生变化，则表示该文件已被打印过；如需删除内存中的文件，请长按文件列表中的某个文件，进行【全选】【删除】。

6.2 丝料界面



丝料界面包含：进丝，退丝，清洗。

- 进丝与退丝时，用户可根据实际需要安装的丝料进行选择，若界面中无当前所需的丝料，用户可以自定义丝料，设置进丝时所需的温度。
- 丝料清洗：当前后两次打印的丝料不同时，请进行丝料清洗。如此可避免发生由于丝料的熔融温度不同造成丝料碳化堵头或不出丝的情况。从温度高的丝料切换到打印温度低的丝料时，此操作必须执行；例如使用PC材料打印后，切换为PLA材料，需将PC材料从喷嘴中清洗干净，因此需要设置PC熔化所需的温度，直至PC材料全部从喷嘴中被挤出，没有残留在喷嘴中。

6.3 预热界面



预热界面可以根据需要提前设置喷头，腔体，平台的温度。

6.4 工具界面



工具界面包含：

【调平-校准】：

手动校准：Z轴校准，XY轴校准，专家模式

辅助校准：喷头传感器校准，自动调平

【网络】：无线网络，有线网络，热点

【手动控制】：手动移动设备XYZ轴

【回零】：设备各轴回到零点位置

【云平台】：连接闪铸云平台

【关于】：关于设备的基本信息

【状态】：设备的运行状态

【维护】：维护条目，用户若遇问题，可在此处查看

【升级】：固件升级，可在无线网络连接时，升级到设备最新的固件

6.5 设置界面



在设置界面中可开启或关闭各项功能。

- 喷头型号的选择与设备进丝及打印温度设置有关，请务必选择与设备安装匹配的喷头。
- 丝料检测功能开启时，设备将会在打印中途丝料用完时停止打印。
- 自动关机功能开启时，设备将会在模型打印完成后自动关机。
- 断电续打功能开启时，若设备打印中途突遇断电，设备将会自动存储当前打印的位置数据，在电源恢复后可继续进行当前模型的打印。
- 空气过滤功能开启时，设备背部风扇启动；风扇前部装有HEPA滤棉以及活性炭滤棉，可以过滤打印时产生的粉尘和异味。
- 腔体保温功能开启时，可设置打印前后的温度保温时间。由于部分材料的特性，需要保持打印前后的热平衡。
- 平台保温功能开启时，可设置打印前后的平台保温时间。取模型过渡状态时，避免消耗温度下降需重新加热的的时间。此功能开启时，在打印完成后取模型时平台仍保持加热状态，请注意高温并避免烫伤。

第七章 维护

7.1 维护界面

可在维护界面中查询当前所遇问题项。

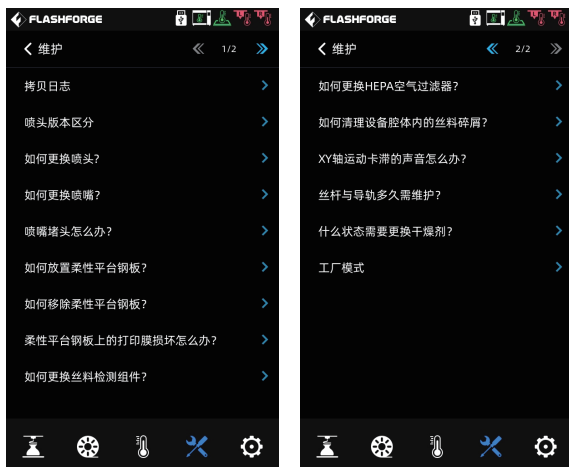

7.2 喷头维护详细介绍

7.2.1 喷头零件图示

⚠ 注意事项 操作喷头时，需断开电源。

左喷头组件

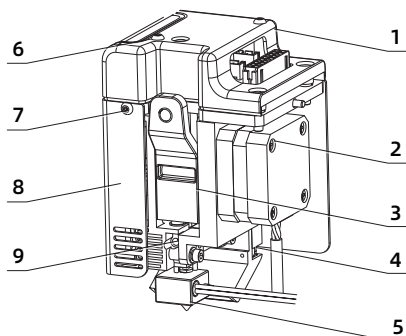

1. 左喷头上盖
2. 送丝电机
3. 左把手
4. 模型散热风扇
5. 左喷嘴组件
6. 内六角平圆头螺钉M3*30
7. 内六角平圆头螺钉M3*6
8. 左喷头钣金外壳

右喷头组件

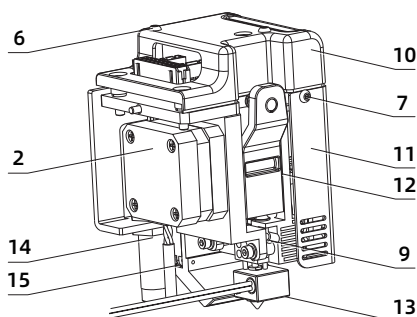

9. M4*3螺丝
10. 右喷头上盖
11. 右喷头钣金外壳
12. 右把手
13. 右喷嘴组件
14. 接近传感器
15. 模型散热风扇

如上图所示，设备带有2个喷头。按方向性，称为左喷头和右喷头。喷头组件相关的零件和数目一致，但左右对称，不可随意互换使用。

7.2.2 喷嘴堵头清理

方法一：

1. 把喷嘴加热至所用材料的匹配温度；
2. 拔出导丝管，按压把手，拔出丝料；
3. 观察丝料的头部是否有弯折，若有，剪掉丝料头部的弯折部分后将导丝管和丝料重新插入喷头，点击【进丝】，喷嘴会重新出丝。

方法二：

加热喷嘴，把通针插入喉管和喷嘴，挤出喷嘴内部丝料。

方法三：

若方法一和方法二操作无效，请更换喷嘴组件。点击【维护】-【如何更换喷嘴】，按屏幕示意操作。即如下方式：

⚠ 注意事项 查看完屏幕所示步骤后先将设备断电，再更换喷嘴组件。



7.2.3 平台平面度校准

用户一般无需进行此操作，当设备平面度经过各种校准或者自动调平补偿无效的时候，可能是平台安装的平面度已受到破坏，此时需要进行初始的平台调平。

♥ 特别提示 此操作可联系闪铸科技售后人员，进行远程协助校准。

请按如下操作：总计调平点位置4个。

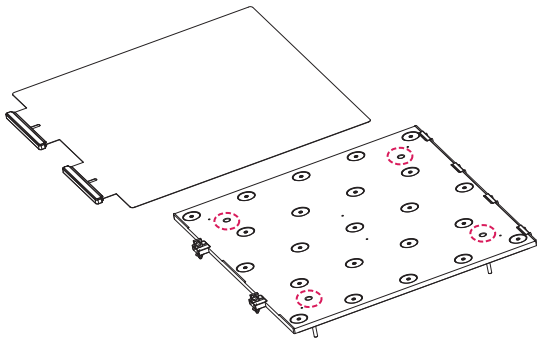

1. 移除柔性钢板；
2. 松开（注意仅需要松开，不需要卸下螺丝）平台上的4颗锁定螺丝；

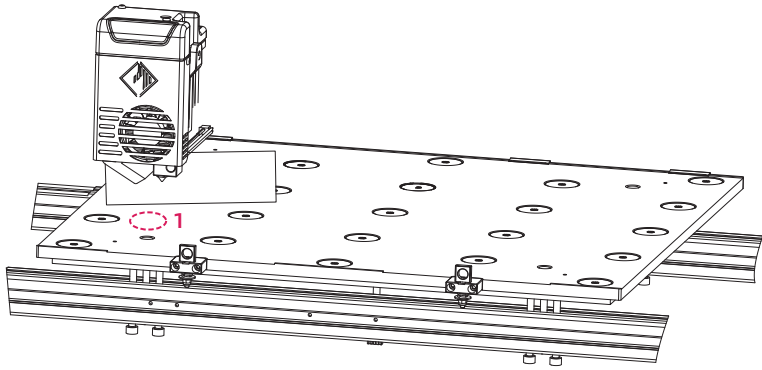

3. 点击屏幕【工具】-【手动控制】点击Z轴上升箭头，手动将喷头移动到位置1（即调平螺丝上方）；在Z轴上升到快要触碰喷嘴的位置时停止；在平台板与喷嘴之间插入调平卡，同时调节型材下方M5*60的左螺丝；滑动调平卡感受有阻力时即为合适位置。然后调节型材下方的右螺丝，调节方式与左螺丝一致；

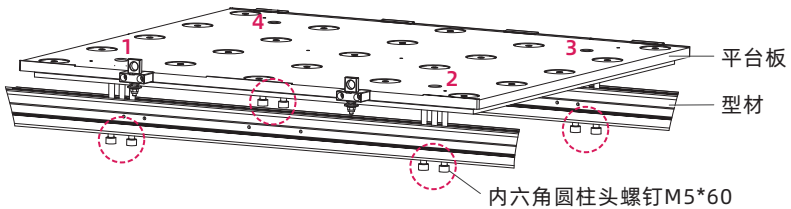

4. 手动移动喷头到位置2，请务必慢慢移动，若喷头划到平台，需要对应调整位置2型材下方M5*60的左螺丝，滑动调平卡确认喷嘴与平台间距合适，然后调节右螺丝；
5. 依次按同样的操作方式调节位置3，位置4；
6. 4个位置都调节完成后，请拧紧平台上方的4颗螺丝，锁定平台。

第八章 Q&A

Q1. 喷嘴堵头怎么办？

点击【工具】-维护说明。

Q2. 如何更换喷嘴？

⚠ 注意事项 更换喷嘴请先关机断电，请勿带电操作。

点击【工具】-维护说明。

Q3. 更换喷嘴后需要校准喷头吗？

不需要。

Q4. 点击打印模型，喷头运动，但打印一开始就没有出丝怎么办？

1. 观察导丝管，确认丝料是否已进入喷头，若无，请再点击进丝按钮，直至丝料从喷头中吐出；
2. 查看喷头是否堵头，若是，解决方案请查看Q1。

Q5. 打印时发现喷嘴与平台相对位置过高（远离平台）或过低（顶到平台）怎么办？如何调平？

在工具页面，选择【调平-校准】-Z轴校准，按页面提示操作。

Q6. 可以使用其他品牌的丝料吗？

可以使用其他品牌丝料，但由于不同材料参数温度略有区别，需要经过参数调整配置。

Q7. 产品兼容所有AC输入吗？

产品适配220V-240V或100-120VAC的输入电压。不同区域之间若输入电压不同不能直接上电使用，即110VAC电压的国家需购买对应110VAC电压的设备。

Q8. 产品打印完成后可以自动关机吗？

可以。

Q9. 打印ABS材料安全吗？

ABS在加热过程中会释放有毒气体，建议打印时或打印后开启HEPA空气过滤器进行过滤。如条件允许，建议将设备置放在开阔环境下打印。儿童活动场所建议打印PLA无毒材料。

Q10. 打印模型发生翘边或粘不牢现象怎么办？

方案1： 增加平台温度可有效缓解此问题，高温可增加平台与模型的粘附力。

方案2： 模型切片时选择添加底板可有效缓解此问题。

方案3： 涂抹胶水。

方案4： 喷嘴与平台的间隙过大，可相应减小间隙，使用喷头校准专家模式或调平校准功能进行间隙调整。

方案5： 确认平台是否放平。可使用调平校准功能，建议执行完全流程的自动调平。

Q11. 打印模型时必须增加底板吗？

不一定。打印底板时出丝量较多，打印成功率较高。在底板加热的条件下，模型与平台板的粘附性增加，使得模型打印时能很好的粘附在平台上，同样也能增加打印成功率。

Q12. 插入U盘后找不到打印文件，屏幕显示全为文件夹怎么办？

U盘格式不正确，设备支持FAT32格式的文件系统，请将U盘格式化成FAT32格式。

Q13. 校准何为专家模式？

专家模式可直接调整间隙数值，跳过完整的校准步骤，适合有经验的用户操作。详情可查看屏幕校准说明中的专家模式讲解。

Q14. Wi-Fi连接不上怎么办？

1. 请检查Wi-Fi名称是否含有特殊字符，如果有，请修改之后再次尝试；
2. 请检查密码是否含有特殊字符，如果有，请修改之后再次尝试。

Q15. 更新固件注意事项

请不要在下载或更新固件时断电断网，防止更新失败。

Q16. 为什么开机屏幕白屏？

如果听到开机声音，请更换屏幕或者排线；否则请联系售后人员。

Q17. 设备打印过程中发生死机黑屏？

请重新开机，拷贝固件log后发送给闪铸科技售后工程师进行对接处理。

第九章 帮助与支持

闪铸专业的售后服务人员及业务员随时为您待命，非常乐意为您解决在您使用过程中遇到的任何问题。如果您无法从用户手册中找到答案，您可以进入我们的官方网站来搜索问题的解决方案，或者通过电话联系我们。

在我们的官网中可以找到一些常见问题的说明和解决方法。您的许多问题都可以在闪铸科技中文官方网站www.sz3dp.com得到解决。

您可以在周一到周六上午8:00到下午5:00通过电话来联系闪铸售后团队，为您解决问题。如果您在下班时间联系我们，闪铸将在下一个工作日的第一时间给您反馈。若造成不便，我们万分抱歉。

提示：由于更换不同的丝料，会有少量杂质残留在喷头中造成喷头堵塞，疏通后即可，不属于质量问题。若用户使用时存在该问题，请联系售后，并在售后的指导下完成疏通工作。

售后服务热线：400-886-6023

邮箱：support@flashforge.com

公司地址：浙江省金华市婺城区仙源路518号

提示：联系售后时，需提供产品序列号，即打印机背部的条形码





Follow us

Zhejiang Flashforge 3D Technology Co., Ltd.

Address: No.518 XianYuan Road, Jinhua City, Zhejiang Province, China

Service Hotline: +86 579 82273989

support@flashforge.com