

CHARCOAL BARBECUE GRILL

WITH WEATHER RESISTANT ENAMELLED BOWL

CLEARLINE[®]
APPLIANCES

LIFE MADE SMART

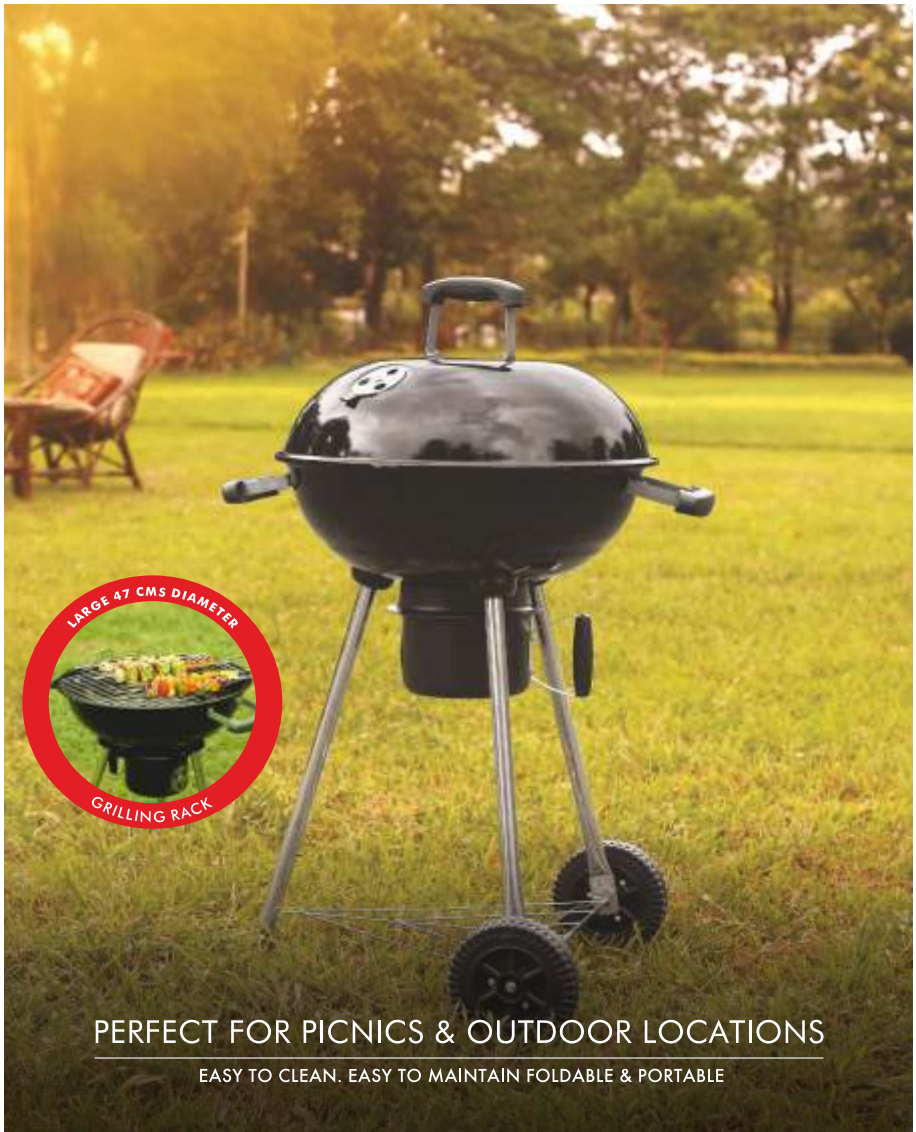

LARGE 47 CMS DIAMETER

GRILLING RACK

PERFECT FOR PICNICS & OUTDOOR LOCATIONS

EASY TO CLEAN. EASY TO MAINTAIN FOLDABLE & PORTABLE

IMPORTANT: Read these instructions fully before using the Appliance.
Retain these instructions for future reference.

DESCRIPTION OF PARTS -

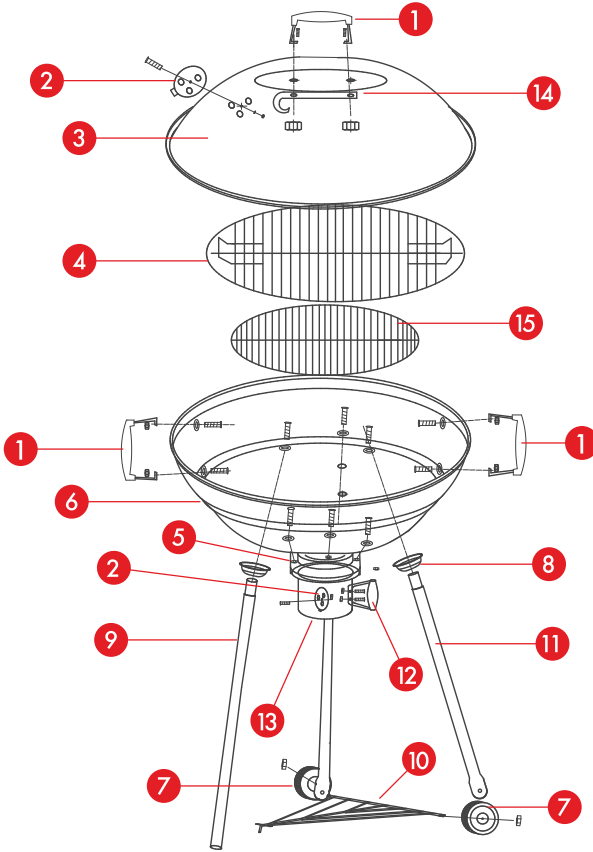

1	
2	
3	
4	
5	
6	
7	
8	
9	
10	
11	
12	
13	
14	
15	

- | | | | |
|---|----------------------|----|------------------------------|
| 1 | Handle | 8 | Bowl Shaped Cups to fix Legs |
| 2 | Air Vents / Dampers | 9 | Leg without Wheel |
| 3 | Top Cover | 10 | Triangle Support |
| 4 | Grill Rack | 11 | Legs with Wheels |
| 5 | Ash Collector Holder | 12 | Ash Collector Handle |
| 6 | Main Grill Base | 13 | Ash Collector |
| 7 | Wheels | 14 | C Shaped Metal Strip |
| | | 15 | Charcoal Rack |

FOR YOUR SAFETY -

- The Grill may get very hot when it is being used.
- For outdoor use only. The grill should not be used in a room, house, building or any enclosed area.
- Always ensure that there is at least 3 feet clearance around all sides while the grill is in use.
- Do not move the grill when it is hot i.e. when it is in use.
- Always place the grill on a firm and level surface.
- Keep away from wooden fences, trees, sheds and fuel tanks.
- When handling the grill, it is advisable to use heat resistant gloves.
- Read all instructions carefully prior to assembly and use.
- Do not use the grill unless it is completely assembled as per instructions.
- Keep all combustible items and surfaces at least 3 feet away from the grill at all times.
- DO NOT use this grill near an explosive atmosphere.
- DO NOT TOUCH hot metal parts of grill until it has completely cooled to avoid burns, unless you are wearing protective gear (BBQ mittens, pot-holders, etc.)
- Do not alter this grill in any manner.
- The use of alcohol, prescription, or non-prescription drugs may impair the operator's ability to properly assemble or safely operate the grill.
- DO NOT LEAVE A LIT GRILL UNATTENDED. Keep children and pets away from the grill at all times.
- DO NOT place this grill on any type of tabletop surface.
- Do not use the grill in high winds.
- All cleaning should be done when grill is cool.

HOW TO ASSEMBLE -

1. Start by laying down all the parts on a table and familiarize yourself with the different parts and the different screws.
2. Place the Main Grill Base (part No.6) upside down and start off by attaching the 3 legs (part Nos. 9 &11) with the help of the 3 Cups (part No.8) Use Screw A + Washer for this.



3. Now place the Ash Collector Holder (part No.12) between the 3 legs and align it with the holes in the Grill Base) and use Screw B + Washer to tighten it.



4. If you look closely, the ends of the 3 legs have holes in them. The Triangle Support (part No.10) will fit perfectly in there. Make sure that the pointed end faces upwards (when the grill is kept upside down) for it to be tight.

Note: The pointed end will fix in the leg which does not have provision for fixing of wheel.



5. Now place the Wheels (part No.7) at the ends of the two sides of the Triangle Support and tighten using Nut A'.



6. Place the grill in an upright position.
7. Next, with the help of screws and washers in the packet labelled Screw C + Washer , fit 2 Handles (part No.1) on each side of the Main Grill Base (part No.6).



8. Please note the C Metal Strip (part No.14) will be fixed inside the Top Cover (part No.3) while fitting the handle. The Metal Strip helps in resting the Top Cover on the side of the Main Grill Base while using the grill.



9. There are 2 Air Vents/Dampers (part No.2). One will be fixed on the Top Cover and the other one will fit onto the ash collector (part No.13) . Use Screw D + Washer to fix these. The Air Vents/Dampers help you control the temperature of the coal by letting in more/less oxygen.



10. The Ash Collector has a handle for easy removal and insertion. Attach the Handle (part No.1) using screw D + Washer .



11. Slide in the Ash Collector into the Ash Collector Holder.



COOKING WITH CHARCOAL –

Arrange a small quantity of charcoal in a pyramid shape, in the body center of your BBQ. Sprinkle a little cooking oil or kerosene onto the charcoal and set it alight. Fan the flames till the charcoal catches fire and starts to glow. You can also use a hair dryer to “fan the flames”. Alternatively you can use a starter to light the charcoal and pour in the grill.

In around 20 to 30 minutes the charcoal will reach cooking temperature. Start to spread the charcoal when ash begins to form on the pyramid of charcoal. You can also add some more charcoal to the top and side till it covers the entire cooking area.

TIPS:

- Coat the grill with some oil to prevent food from sticking to the grill.
- Sometimes, the fire can flare when oil/fat drips on the fire. Do not get alarmed by this, the flame will extinguish on its own.

CLEANING & MAINTAINENCE -

- After the grill has cooled down, sweep the ash/charcoal into the Ash Collector.
- All accessories should be soaked in hot water after use to prevent food from being stuck to them.
- All metal parts should be wiped with warm soapy water and then dried thoroughly by using a soft cloth.

CLEARLINE CUSTOMER SERVICE

This product carries a Warranty of 12 months from the date of purchase against defects caused by faulty workmanship and materials. The Warranty excludes defects caused by the product not being used in accordance with instructions, misuse, accidental damage and tampering with by unauthorized persons. In the event of any defect arising during Warranty Period, the same should be taken to your nearest dealer or wholesaler. It will then be taken care of as per the discretion of the company's representative. The warranty does not cover normal wear and tear, enamel and rusting of metal parts over a period of time.

WARRANTY CARD

Serial No. _____ Bill No. _____

Model No. CHARCOAL BARBECUE GRILL - ROUND 47 CM _____

Customer's Name : _____

Address : _____

Date of Purchase : _____

Dealer's Name & Stamp



L I F E M A D E S M A R T

Manufactured & Marketed by:

CLEARLINE APPLIANCES LIMITED

177G, Industrial Area, Phase-I, Chandigarh - 160002

Incase of any complaints please contact: +91 172 4647707

or email us at customercare@clearline.co.in or write to us at the above mentioned address

www.clearline.co.in
