



BEVERAGE-AIR

Project: _____

AIA#

Item: _____

Location: _____

SIS#

Approved: _____

WTRD REFRIGERATORS WITH DRAWERS

WTRD72AHC Four Drawer Worktop Refrigerators Hydrocarbon Series

MODELS:
WTRD72AHC-4



WTRD72AHC-4

3 Year Parts/Labor Warranty
Additional 2 Year Compressor Warranty

CABINET CONSTRUCTION

- Stainless steel front, sides, door and drawers (*galvanized back & bottom*)
- Interior liner is made of corrosion resistant aluminum
- Stainless steel worktop for added durability
- Full electronic control
- Interior thermometer is standard
- 4" Removable backsplash for flexibility and ease of cleaning
- Two (2) epoxy coated shelves
- Painted aluminum door and drawer handles
- Snap-in door and drawer gaskets
- Upper and lower pull-out drawers accommodate 6" deep pans
- Stainless steel drawer frames supported on telescoping drawer slides
- Drawer slides include locking mechanism that prevents drawer from being inadvertently pulled off cabinet
- 6" Casters, (2) with brakes standard
- Maintains product temperature between 36°F and 38°F

OPTIONS & ACCESSORIES

- Stainless steel back and grille
- Stainless steel interior
- Right or left hinged door
- Locks (solid doors only)
- Bun rack
- Wire shelf divider
- Cutting board
- Thermometer digital or stem type dial
- 3" Casters or 6" legs
- Low profile casters
- Remote option

REFRIGERATION SYSTEM

- Refrigeration system uses R290 refrigerant to comply with all environmental concerns
- Automatic, non-electric defrost
- Epoxy coated evaporator coil

WTRD72AHC-4 Refrigerators With Drawers: Worktop Series



3779 Champion Blvd., Winston-Salem, NC 27105
1-888-845-9800 Fax: 1-336-245-6453
Beverage-Air.com sales@bevair.com



BEVERAGE-AIR

| MODEL | WTRD72AHC-4 |
|----------------------------------|---|
| EXTERNAL DIMENSIONAL DATA | |
| Width Overall | 72" |
| Depth Overall | 32" |
| Height Overall with 6" Casters | 39 5/8" |
| Number of Doors | 1 |
| Depth with Door Open 90 ° | 52 3/8" |
| Clear Door Opening (inches) | Upper 19 1/2" x 11 1/4" Lower 19 1/2" x 7 1/2" |
| Drawer Open Extender | 48" |
| Number of Drawers | 4 |
| INTERNAL DIMENSIONAL DATA | |
| NET Capacity (cubic ft.) | 17.88 |
| Internal Width Overall (in) | 68" |
| Internal Depth Overall (in) | 23 1/2" |
| Internal Depth Useable (in) | Upper 18 1/2" Lower 15 3/8" |
| Internal Height Overall (in) | 23" |
| Number of Shelves | 2 |
| ELECTRICAL DATA | |
| Full Load Amperes 115/60/1 | 3.0 |
| REFRIGERATION DATA | |
| Horsepower | 1/5 |
| Capacity (BTU/Hr)* | 1350 |
| WEIGHT DATA | |
| Gross Weight (Crated lbs) | 370 lbs |
| Height - Crated | 35" |
| Width - Crated | 74" |
| Depth - Crated | 33" |

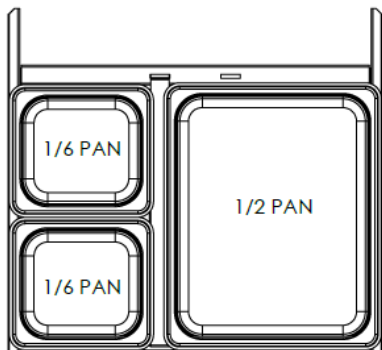

Worktop Refrigerators – With Drawers Models: WTRD72AHC-4 Removable Backsplash

Model Views

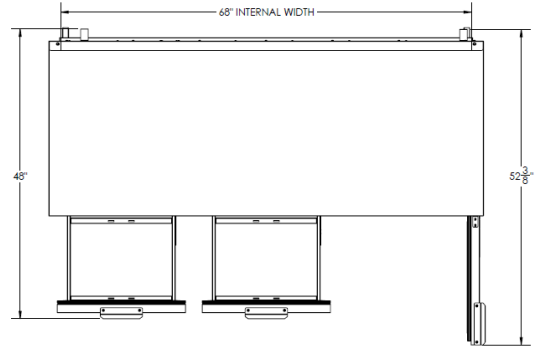

Plan View

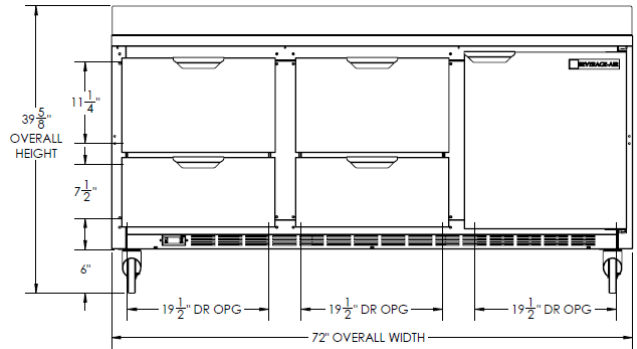

Elevation View

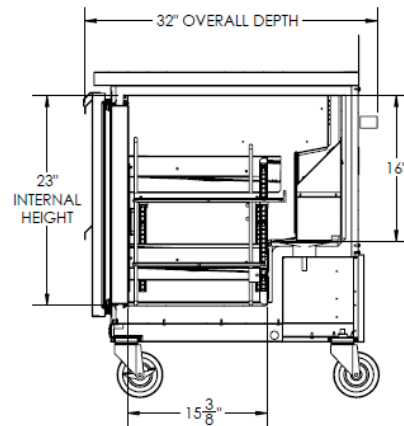

Side View

ELECTRICAL CONNECTION



115/60/1
NEMA-5-15P

Units pre-wired at factory and include 8' long cord and plug set.



an Ali Group Company



The Spirit of Excellence

3779 Champion Blvd., Winston-Salem, NC 27105
1-888-845-9800 Fax: 1-336-245-6453
Beverage-Air.com sales@bevair.com