



BEVERAGE-AIR

Project: _____

AIA#

Item: _____

Location: _____

SIS#

Approved: _____

WTRD REFRIGERATORS WITH DRAWERS

WTRD72AHC Two Drawer Flat Worktop Refrigerator
Hydrocarbon Series

MODELS:
WTRD72AHC-2-FLT



WTRD72AHC-2-FLT

3 Year Parts/Labor Warranty
Additional 2 Year Compressor Warranty

CABINET CONSTRUCTION

- Stainless steel front, sides, doors and drawers (*galvanized back & bottom*)
- Interior liner is made of corrosion resistant aluminum
- Stainless steel worktop for added durability
- Full electronic control
- Interior thermometer is standard
- Flat worktop
- Painted aluminum door and drawer handles
- Four (4) epoxy coated shelves
- Snap-in door and drawer gaskets
- Upper and lower pull-out drawers accommodate 6" deep pans
- Stainless steel drawer frames supported on telescoping drawer slides
- Drawer slides include locking mechanism that prevents drawer from being inadvertently pulled off cabinet
- 6" Casters, 2 with brakes standard
- Maintains product temperature between 36°F and 38°F

OPTIONS & ACCESSORIES

- Stainless steel back and grille
- Stainless steel interior
- Right or left hinged door
- Locks (solid doors only)
- Bun rack
- Wire shelf divider
- Cutting board
- Thermometer digital or stem type dial
- 3" Casters or 6" legs
- Low profile casters
- Remote option

REFRIGERATION SYSTEM

- Refrigeration system uses R290 refrigerant to comply with all environmental concerns
- Automatic, non-electric defrost
- Epoxy coated evaporator coil

WTRD72AHC-2-FLT Refrigerators With Drawers: Worktop Series



3779 Champion Blvd., Winston-Salem, NC 27105
1-888-845-9800 Fax: 1-336-245-6453
Beverage-Air.com sales@beva.com



BEVERAGE-AIR

MODEL	WTRD72AHC-2-FLT
EXTERNAL DIMENSIONAL DATA	
Width Overall	72"
Depth Overall	32"
Height Overall with 6" Casters	35 5/8"
Number of Doors	2
Depth with Door Open 90 °	52 3/8"
Depth with Drawer Extended	48"
Number of Drawers	2
Drawer Openings (in)	Upper 19 1/2" x 11 1/4" Lower 19 1/2" x 7 1/2"
INTERNAL DIMENSIONAL DATA	
NET Capacity (cubic ft.)	17.88
Internal Width Overall (in)	68"
Internal Depth Overall (in)	23 1/2"
Internal Depth Useable (in)	Upper 18 1/2" Lower 15 3/8"
Internal Height Overall (in)	23"
Number of Shelves	4
ELECTRICAL DATA	
Full Load Amperes 115/60/1	3.0
REFRIGERATION DATA	
Horsepower	1/5
Capacity (BTU/Hr)*	1350
WEIGHT DATA	
Gross Weight (Crated lbs)	370 lbs
Height - Crated	35"
Width - Crated	74"
Depth - Crated	33"

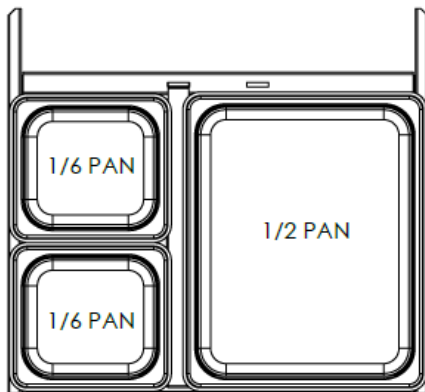

Worktop Refrigerators – With Drawers

Models: WTRD72AHC-2-FLT

Model Views

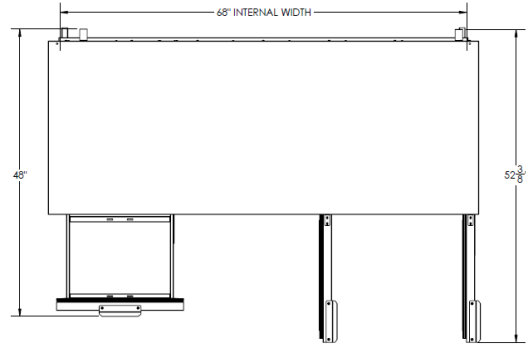

Plan View

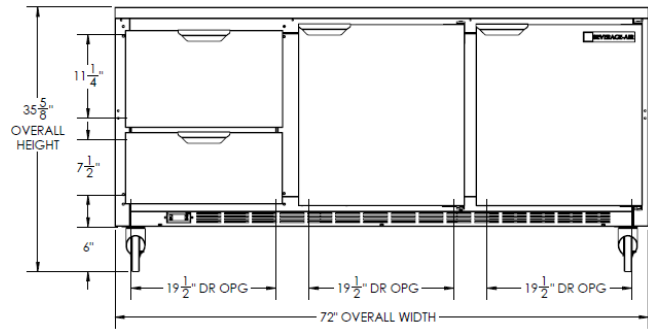

Elevation View

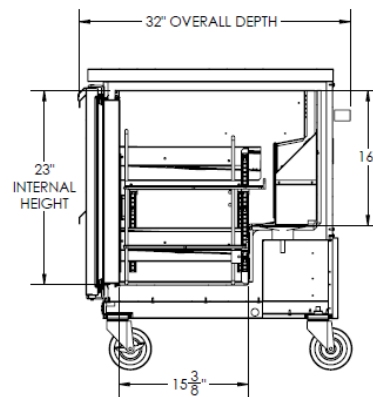

Side View

ELECTRICAL CONNECTION



115/60/1
NEMA-5-15P

Units pre-wired at factory and include 8' long cord and plug set.



an Ali Group Company



The Spirit of Excellence

3779 Champion Blvd., Winston-Salem, NC 27105
1-888-845-9800 Fax: 1-336-245-6453
Beverage-Air.com sales@bevair.com