



BEVERAGE-AIR

Project: _____

AIA#

Item: _____

Location: _____

SIS#

Approved: _____

WTRD REFRIGERATORS WITH DRAWERS

WTRD67AHC Four Drawer Worktop Refrigerators
Hydrocarbon Series

MODELS:
WTRD67AHC-4

WTRD67AHC Refrigerators With Drawers: Worktop Series

3 Year Parts/Labor Warranty
Additional 2 Year Compressor Warranty

CABINET CONSTRUCTION



WTRD67AHC-4

- Stainless steel front, sides and drawers (*galvanized back & bottom*)
- Interior liner is made of corrosion resistant aluminum
- Stainless steel worktop for added durability
- Full electronic control
- Interior thermometer is standard
- 100 % Front breather
- 4" Built-in backsplash
- Painted aluminum drawer handles
- Snap-in drawer gaskets
- Upper and lower pull-out drawers accommodate 6" deep pans
- Stainless steel drawer frames supported on telescoping drawer slides
- Drawer slides include locking mechanism that prevents drawer from being inadvertently pulled off cabinet
- 6" Casters, (2) with brakes standard
- Operates at 36° –38°F for optimum food preservation

OPTIONS & ACCESSORIES

- Stainless steel back and grille
- Stainless steel interior
- Combination units available
- 6" Legs
- 3" Casters
- Low profile casters
- Food service pans
- Cutting board
- Remote option

REFRIGERATION SYSTEM

- Refrigeration system uses R290 refrigerant to comply with all environmental concerns
- Automatic, non-electric evaporator
- System is serviceable from front
- Epoxy coated evaporator coil



3779 Champion Blvd., Winston-Salem, NC 27105
1-888-845-9800 Fax: 1-336-245-6453
Beverage-Air.com sales@bevair.com



BEVERAGE-AIR

Worktop Refrigerators – With Drawers

Models: WTRD67AHC-4

MODEL	WTRD67AHC-4
EXTERNAL DIMENSIONAL DATA	
Width Overall	67"
Depth Overall with Countertop & Bumper	34"
Height Overall with 6" Casters	39 1/2"
Number of Drawers	4
Depth with Drawers Open Extended	55 1/2"
Drawers Opening (in)	Upper 21 5/8" x 10 3/8" Lower 21 5/8" x 10 3/8"
INTERNAL DIMENSIONAL DATA	
NET Capacity (cubic ft.)	18.97
Internal Width Overall (in)	48"
Internal Depth Overall (in)	26"
Internal Height Overall (in)	25"
ELECTRICAL DATA	
Full Load Amperes 115/60/1	3
REFRIGERATION DATA	
Horsepower	1/5
Capacity (BTU/Hr)*	1350
WEIGHT DATA	
Gross Weight (Crated lbs)	450 lbs
Height - Crated	46 1/2"
Width - Crated	70"
Depth - Crated	37"

Model Views

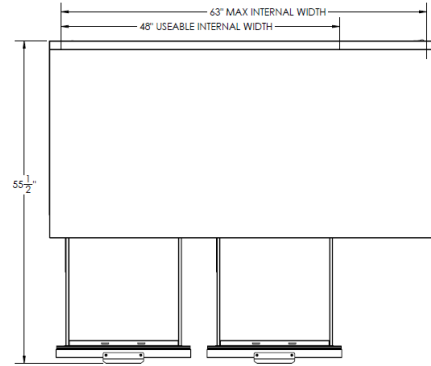

Plan View

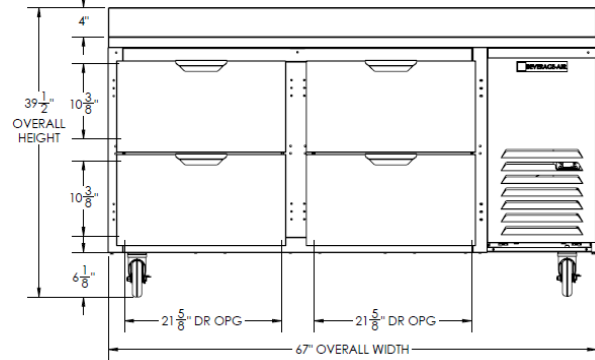

Elevation View

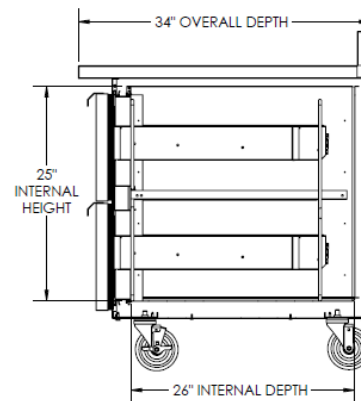

Side View

ELECTRICAL CONNECTION



115/60/1
NEMA-5-15P

Units pre-wired at factory and include 8' long cord and plug set.



an Ali Group Company



The Spirit of Excellence

3779 Champion Blvd., Winston-Salem, NC 27105
1-888-845-9800 Fax: 1-336-245-6453
Beverage-Air.com sales@bevair.com