



# BEVERAGE-AIR

Project: \_\_\_\_\_

AIA#

Item: \_\_\_\_\_

Location: \_\_\_\_\_

SIS#

Approved: \_\_\_\_\_

## WTRD REFRIGERATORS WITH DRAWERS

### WTRD119AHC Eight Drawer Worktop Refrigerators

### Hydrocarbon Series

**MODELS:**

**WTRD119AHC-8**



**WTR119AHC-8**

**3 Year Parts/Labor Warranty**  
**Additional 2 Year Compressor Warranty**

### CABINET CONSTRUCTION

- Stainless steel front, sides and drawers (*galvanized back & bottom*)
- Interior liner is made of corrosion resistant aluminum
- Stainless steel worktop for added durability
- Full electronic control
- Interior thermometer is standard
- 4" Built-in backsplash
- Painted aluminum drawer handles
- Snap-in drawer gaskets
- Upper and lower pull-out drawers accommodate 6" deep pans
- Stainless steel drawer frames supported on telescoping drawer slides
- Drawer slides include locking mechanism that prevents drawer from being inadvertently pulled off cabinet
- 6" Casters, three (3) with brakes standard
- Operates at 36° -38°F for optimum food preservation

### OPTIONS & ACCESSORIES

- Stainless steel back and grille
- Stainless steel interior
- Combination models available
- 6" Legs
- 3" Casters
- Low profile casters
- Food service pans
- Cutting board
- Remote option

### REFRIGERATION SYSTEM

- Refrigeration system uses R290 refrigerant to comply with all environmental concerns
- Automatic, non-electric evaporator
- System is serviceable from front
- Epoxy coated evaporator coil

WTRD119AHC Refrigerators with Drawers: Worktop Series



3779 Champion Blvd., Winston-Salem, NC 27105  
1-888-845-9800 Fax: 1-336-245-6453  
Beverage-Air.com sales@bevair.com



# BEVERAGE-AIR

MODEL	WTRD119AHC-8
<b>EXTERNAL DIMENSIONAL DATA</b>	
Width Overall	119"
Depth Overall with Handle & Bumper	34"
Height Overall with 6" Casters	39 1/2"
Depth with Drawer Extended	55 1/2"
Drawer Opening (in)	Upper 21 5/8" x 10 3/8" Lower 21 5/8" x 10 1/4"
<b>INTERNAL DIMENSIONAL DATA</b>	
NET Capacity (cubic ft.)	40.12
Internal Width Overall (in)	99 7/8"
Internal Depth Overall (in)	26"
Internal Height Overall (in)	25"
Number of Drawers	8
<b>ELECTRICAL DATA</b>	
Full Load Amperes 115/60/1	4.9
<b>REFRIGERATION DATA</b>	
Horsepower	1/3
Capacity (BTU/Hr)*	2629
<b>WEIGHT DATA</b>	
Gross Weight (Crated lbs)	604 lbs
Height - Crated	46 1/2"
Width - Crated	122"
Depth - Crated	37"

## Worktop Refrigerators – With Drawers

Models: WTRD119AHC-8

### Model Views

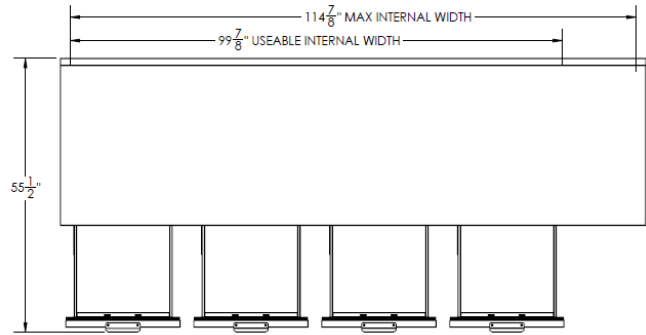

### Plan View

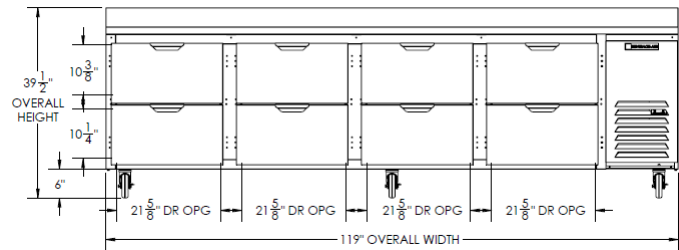

### Elevation View

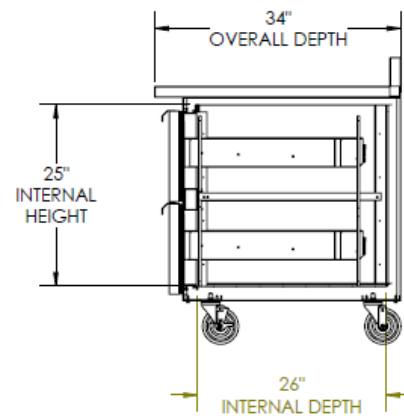

### Side View

### ELECTRICAL CONNECTION



115/60/1  
NEMA-5-15P

Units pre-wired at factory and include 8' long cord and plug set.



an Ali Group Company



The Spirit of Excellence

3779 Champion Blvd., Winston-Salem, NC 27105  
1-888-845-9800 Fax: 1-336-245-6453  
Beverage-Air.com sales@bevair.com