



# BEVERAGE-AIR

Project: \_\_\_\_\_

AIA#

Item: \_\_\_\_\_

Location: \_\_\_\_\_

SIS#

Approved: \_\_\_\_\_

## WTRD REFRIGERATORS WITH DRAWERS

### WTRD119AHC Two Drawer Worktop Refrigerators Hydrocarbon Series

**MODELS:**  
WTRD119AHC-2

**3 Year Parts/Labor Warranty**  
**Additional 2 Year Compressor Warranty**

### CABINET CONSTRUCTION



WTR119AHC-2

- Stainless steel front, sides, doors and drawers (*galvanized back & bottom*)
- Interior liner is made of corrosion resistant aluminum
- Stainless steel worktop for added durability
- Full electronic control
- Interior thermometer is standard
- 100% Front breather
- 4" Built-in backsplash
- Six (6) epoxy coated shelves
- Painted aluminum door and drawer handles
- Snap-in door and drawer gaskets
- Upper and lower pull-out drawers accommodate 6" deep pans
- Stainless steel drawer frames supported on telescoping drawer slides
- Drawer slides include locking mechanism that prevents drawer from being inadvertently pulled off cabinet
- 6" Casters, three (3) with brakes standard
- Maintains product temperature between 36°F and 38°F

### OPTIONS & ACCESSORIES

- Stainless steel back and grille
- Stainless steel interior
- Right or left hinged door
- Locks (solid doors only)
- Bun rack
- Wire shelf divider
- Cutting board
- Thermometer digital or stem type dial
- 3" Casters or 6" legs
- Low profile casters
- Remote option

### REFRIGERATION SYSTEM

- Refrigeration system uses R290 refrigerant to comply with all environmental concerns
- Automatic, non-electric defrost
- Epoxy coated evaporator coil

WTRD119AHC-2 Refrigerators With Drawers: Worktop Series



3779 Champion Blvd., Winston-Salem, NC 27105  
1-888-845-9800 Fax: 1-336-245-6453  
Beverage-Air.com sales@bevair.com



# BEVERAGE-AIR

MODEL	WTRD119AHC-2
<b>EXTERNAL DIMENSIONAL DATA</b>	
Width Overall	119"
Depth Overall	34"
Height Overall with 6" Casters	39 1/2"
Number of Doors	3
Depth with Door Open 90 °	55 1/8"
Number of Drawers	2
Depth with Drawer Extended	55 1/2"
Door Opening (in)	Upper 21 5/8" x 10 3/8" Lower 21 5/8" x 10 1/4"
<b>INTERNAL DIMENSIONAL DATA</b>	
NET Capacity (cubic ft.)	40.12
Internal Width Overall (inches)	99 7/8"
Internal Depth Overall (inches)	26"
Internal Height Overall—(inches)	25"
Number of Shelves	6
<b>ELECTRICAL DATA</b>	
Full Load Amperes 115/60/1	4.9
<b>REFRIGERATION DATA</b>	
Horsepower	1/3
Capacity (BTU/Hr)*	2629
<b>WEIGHT DATA</b>	
Gross Weight (Crated lbs)	604 lbs
Height - Crated	45 1/2"
Width - Crated	122"
Depth - Crated	37"

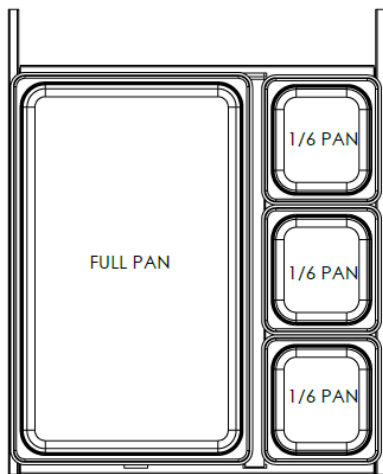

## Worktop Refrigerators – With Drawers

Models: WTRD119AHC-2

### Model Views

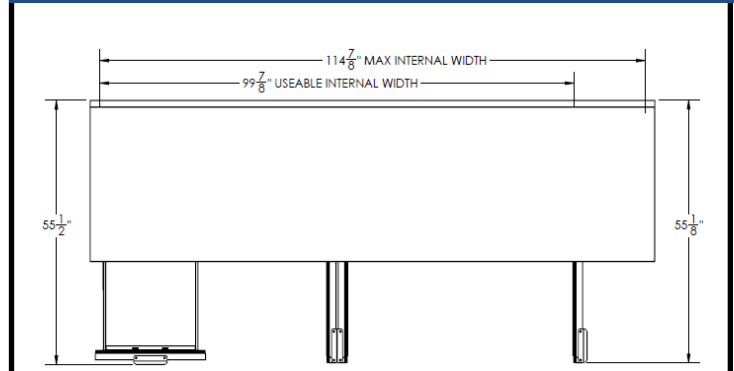

### Plan View

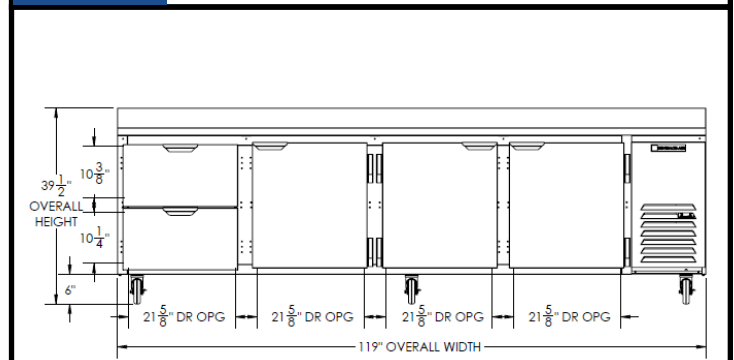

### Elevation View

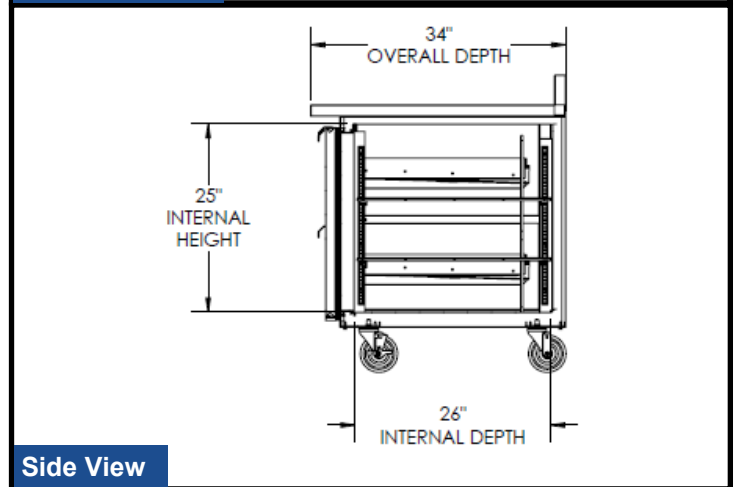

### Side View

### ELECTRICAL CONNECTION



115/60/1  
NEMA-5-15P

Units pre-wired at factory and include 8' long cord and plug set.



an Ali Group Company



The Spirit of Excellence

3779 Champion Blvd., Winston-Salem, NC 27105  
1-888-845-9800 Fax: 1-336-245-6453  
Beverage-Air.com sales@bevair.com