



# BEVERAGE-AIR

Project: _____	AIA#
Item: _____	
Location: _____	SIS#
Approved: _____	

## CHEF BASE REFRIGERATOR

**MODEL:**  
**WTRCS48HC**

WTRCS48HC Two Drawer Chef Base  
Hydrocarbon Series

**WTRCS48HC CHEF BASES REFRIGERATOR**

**3 Year Parts/Labor Warranty**  
**Additional 2 Year Compressor Warranty**

### CABINET CONSTRUCTION



- Stainless steel front, sides, drawers and grille (galvanized back & bottom)
- Interior liner is made of corrosion resistant aluminum
- Top has full marine edge to prevent spills from dripping over sides
- Full electronic control
- 12-Gauge stainless steel drawer slides with Delrin® rollers rated at 275 lbs
- Lifetime warranty on all drawers and slides
- Heavy duty, fire-proof, reinforced insulated 16 gauge top
- No heat shield required (must adhere to proper clearance per owners manual)
- Accommodates 6" deep full size food service pans (not included)
- Self-closing drawer feature
- 3" Casters, 2 with brakes standard
- One-piece, snap-in magnetic drawer gasket

### OPTIONS & ACCESSORIES

- Stainless steel back
- Stainless steel interior
- Additional pan supports
- 6" Adjustable legs, 6" seismic legs
- 6" Casters
- Gasket guards
- Flat top overhang  
(up to 6" overhang on each side)
- Remote option\*  
(refrigerant must be specified at time of order, see note on back on page)

### REFRIGERATION SYSTEM

- Uses environmentally friendly, energy efficient R290 refrigerant, and meets all regulatory requirements for CARB, SNAP, DOE & more
- Adaptive defrost
- Non-electric defrost with hot gas condensate evaporation
- Maintains product temperature 36°F to 38°F



Please verify qualifying units by visiting:  
[www.energystar.gov/cfs](http://www.energystar.gov/cfs)

3779 Champion Blvd., Winston-Salem, NC 27105  
1-888-845-9800 Fax: 1-336-245-6453  
Beverage-Air.com Sales@bevair.com



# BEVERAGE-AIR

MODEL	WTRCS48HC
<b>EXTERNAL DIMENSIONAL DATA</b>	
Width Overall	48"
Depth Overall (with handle & bumper)	34 3/4"
Height Overall (with casters)	24 3/8"
Number of Drawers	2
Depth with Drawers Extended	57 3/4"
Drawer Opening (in)	27 3/8" x 6 1/2"
<b>INTERNAL DIMENSIONAL DATA</b>	
NET Capacity (cubic ft.)	8.59
Internal Width Overall (in)	34 7/8"
Internal Depth Overall (in)	26"
Internal Height Overall (in)	16 3/8"
<b>ELECTRICAL DATA</b>	
Full Load Amperes	1.70
<b>REFRIGERATION DATA</b>	
Horsepower	1/6
Capacity (BTU/Hr)*	1110
<b>WEIGHT DATA</b>	
Gross Weight	374 lbs
Height - Crated	27"
Width - Crated	39"
Depth - Crated	57"

\*NOTE: Remote units are field wired and comes with 6" legs. Refrigerant must be specified at time of order.

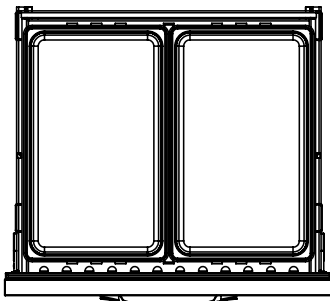

(Per drawer)

## Chef Base Refrigerator Model: WTRCS48HC

### Model Views

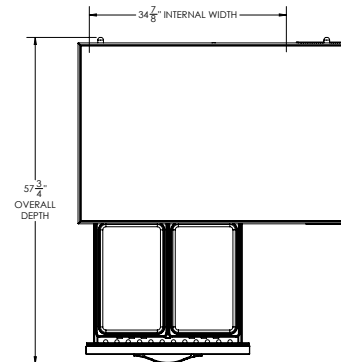

### PLAN VIEW

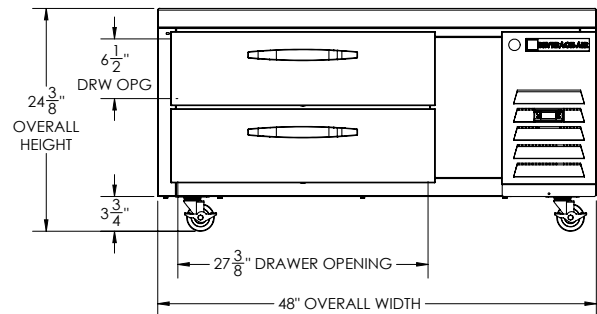

### ELEVATION VIEW

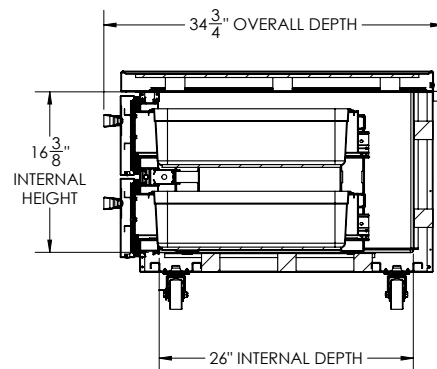

### SIDE VIEW

### \*ELECTRICAL CONNECTION



115/60/1

NEMA-5-15P

Units pre-wired at factory and include 10' long cord and plug set.



an Ali Group Company



The Spirit of Excellence

3779 Champion Blvd., Winston-Salem, NC 27105  
1-888-845-9800 Fax: 1-336-245-6453  
Beverage-Air.com Sales@bevair.com