



BEVERAGE-AIR

Project: _____

AIA#

Item: _____

Location: _____

SIS#

Approved: _____

WTR SHALLOW DEPTH WORKTOP

WTR34HC Solid Door Worktop Refrigerators
Hydrocarbon Series

MODELS:
WTR34HC



WTR34HC

3 Year Parts/Labor Warranty
Additional 2 Year Compressor Warranty

CABINET CONSTRUCTION

- Stainless steel front, sides and doors, (*galvanized back & bottom*)
- Interior liner is made of corrosion resistant aluminum
- Full electronic control
- Stainless steel worktop
- 4" Removable backsplash for flexibility and ease of cleaning
- Interior thermometer is standard
- Self-closing doors with 120° Stay-open feature, on cartridge style hinges
- Magnetic gasket attached to each door for positive seal
- Painted aluminum door handles
- 6" Casters, two (2) with brakes standard
- Two epoxy-coated steel wire shelves standard
- Field-reversible doors
- Operates at 36° –38°F for optimum food preservation

OPTIONS & ACCESSORIES

- Stainless steel back and grille.
- Stainless steel interior available
- Glass doors
- Solid doors with locks
- 6" Legs
- 3" Casters
- Low profile casters
- Foot pedal door opener
- Remote option

REFRIGERATION SYSTEM

- Refrigeration system uses R290 refrigerant to comply with all environmental concerns
- Automatic, non-electric evaporator
- System is serviceable from rear
- Epoxy coated evaporator coil

WTR34HC Shallow Depth Worktop: Food Prep Series



3779 Champion Blvd., Winston-Salem, NC 27105
1-888-845-9800 Fax: 1-336-245-6453
Beverage-Air.com sales@bevair.com



BEVERAGE-AIR

Worktop Refrigerators - Shallow Depth Models: WTR34HC

MODEL	WTR34HC
EXTERNAL DIMENSIONAL DATA	
Width Overall	34"
Depth Overall with Handle & Bumper	24 5/8"
Height Overall with 6" Casters	36 1/8"
Number of Doors	2
Depth with Door Open 90 °	38 1/8"
Door Opening (in)	13 1/8" x 18"
Shelf Area (sq. in)	186 35/94"
INTERNAL DIMENSIONAL DATA	
NET Capacity (cubic ft.)	3.88
Internal Width Overall (in)	30"
Internal Depth Overall (in)	16 3/8"
Internal Depth Useable (in)	Upper 11" Lower 8 1/4"
Internal Height Overall (in)	19 1/2"
Internal Height Useable (in)	12 1/2"
Number of Shelves	2
ELECTRICAL DATA	
Full Load Amperes 115/60/1	2
REFRIGERATION DATA	
Horsepower	1/6
Capacity (BTU/Hr)*	994
WEIGHT DATA	
Gross Weight (Crated lbs)	171 lbs
Height - Crated	32"
Width - Crated	36"
Depth - Crated	25"

Model Views

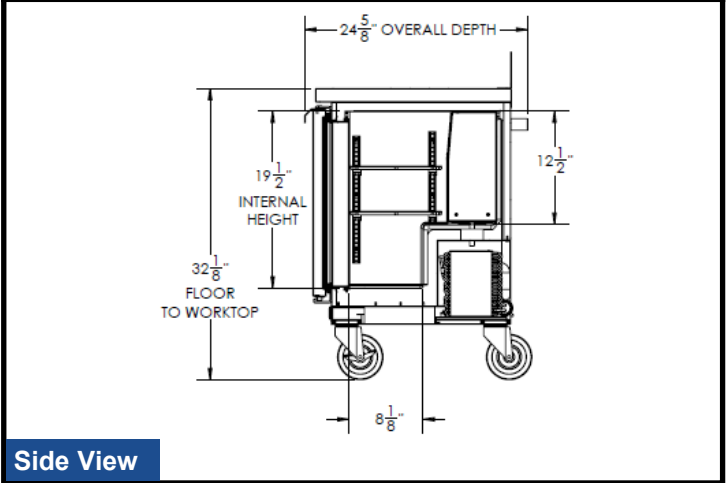
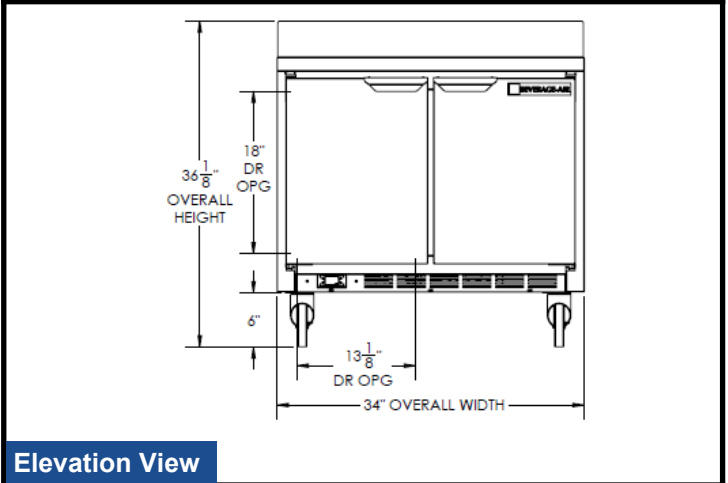
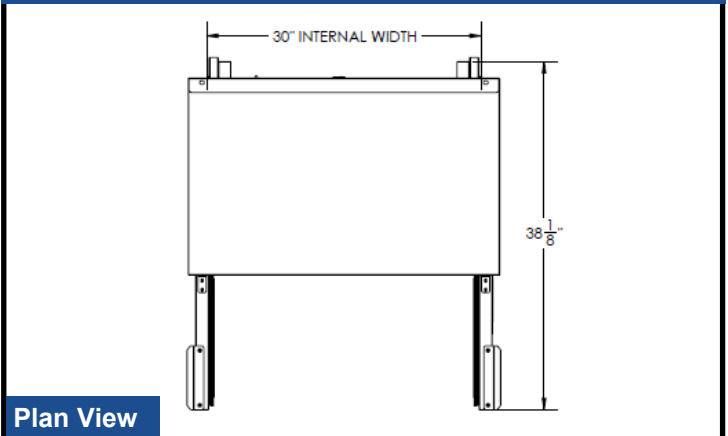

ELECTRICAL CONNECTION



115/60/1
NEMA-5-15P

Units pre-wired at factory and include 8' long cord and plug set.



an Ali Group Company



The Spirit of Excellence

3779 Champion Blvd., Winston-Salem, NC 27105
1-888-845-9800 Fax: 1-336-245-6453
Beverage-Air.com sales@bevair.com