



# BEVERAGE-AIR

Project: \_\_\_\_\_

AIA#

Item: \_\_\_\_\_

Location: \_\_\_\_\_

SIS#

Approved: \_\_\_\_\_

## WTR SHALLOW DEPTH WORKTOP

### WTR27HC Flat Worktop Refrigerators

### Hydrocarbon Series

MODELS:

WTR27HC-FLT



WTR27HC-FLT

**3 Year Parts/Labor Warranty**  
**Additional 2 Year Compressor Warranty**

### CABINET CONSTRUCTION

- Stainless steel front, sides and door, (*galvanized steel back & bottom*)
- Interior liner is made of corrosion resistant aluminum
- Full electronic control
- Flat worktop
- Interior thermometer is standard
- Self-closing doors with 120° stay-open feature, on cam-lift hinges
- Easy door removal for service and cleaning
- Magnetic gasket attached to each door for positive seal
- Painted aluminum door handle
- 6" Casters, two (2) with brakes standard
- Two epoxy-coated steel wire shelves standard
- Field reversible door
- Operates at 36° –38°F for optimum food preservation

### OPTIONS & ACCESSORIES

- Stainless steel back and grille.
- Stainless steel interior available
- Solid doors with lock
- Cutting board top option
- Shelf dividers
- 6" Legs
- 3" Casters
- Low profile casters
- Foot pedal door opener
- Remote option

### REFRIGERATION SYSTEM

- Refrigeration system uses R290 refrigerant to comply with all environmental concerns
- Automatic, non-electric evaporator
- System is serviceable from rear
- Epoxy coated evaporator coil

WTR27HC-FLT Shallow Depth Worktop: Food Prep Series



3779 Champion Blvd., Winston-Salem, NC 27105  
1-888-845-9800 Fax: 1-336-245-6453  
Beverage-Air.com sales@bevair.com



# BEVERAGE-AIR

MODEL	WTR27HC-FLT
<b>EXTERNAL DIMENSIONAL DATA</b>	
Width Overall	27"
Depth Overall with Handle & Bumper	29 7/8"
Height Overall with 6" Casters	35 5/8"
Number of Doors	1
Depth with Door Open 90°	53 1/8"
Door Opening (in)	22 5/8" x 21 5/8"
Shelf Area (sq. in)	186 35/64"
<b>INTERNAL DIMENSIONAL DATA</b>	
NET Capacity (cubic ft.)	3.88
Internal Width Overall (in)	23"
Internal Depth Overall (in)	21 1/2"
Internal Depth Useable (in)	Upper 16" Lower 13 1/8"
Internal Height Front (in)	23"
Internal Height Rear (in)	16"
Number of Shelves	2
<b>ELECTRICAL DATA</b>	
Full Load Amperes 115/60/1	2
<b>REFRIGERATION DATA</b>	
Horsepower	1/6
Capacity (BTU/Hr)*	994
<b>WEIGHT DATA</b>	
Gross Weight (Crated lbs)	172 lbs
Height - Crated	34"
Width - Crated	30"
Depth - Crated	32"

## Worktop Refrigerators - Shallow Depth

Models: WTR27HC-FLT

### Model Views

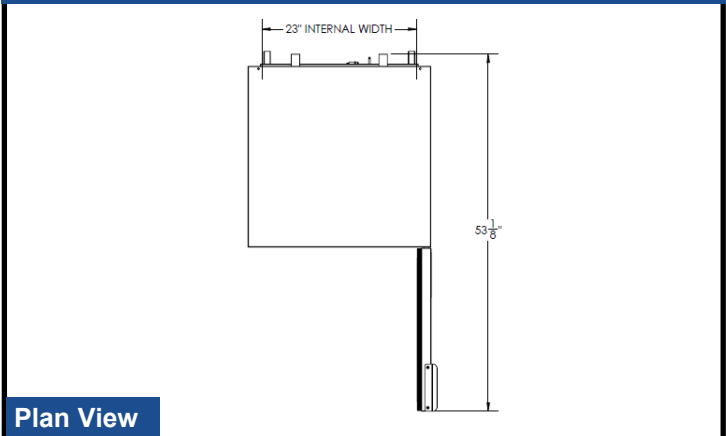

Plan View

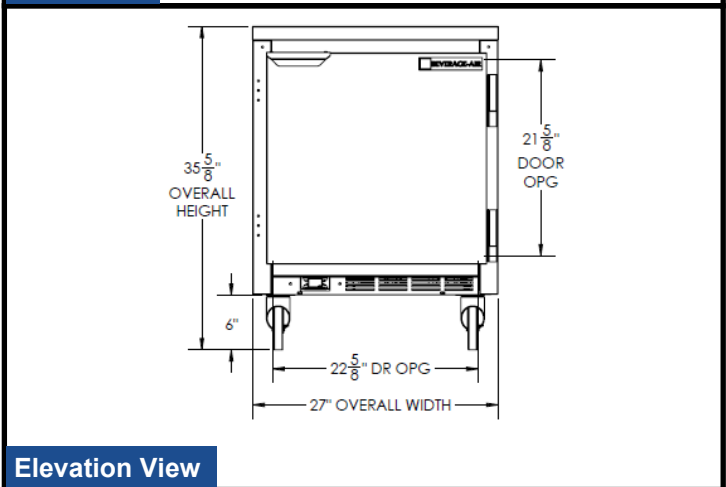

Elevation View

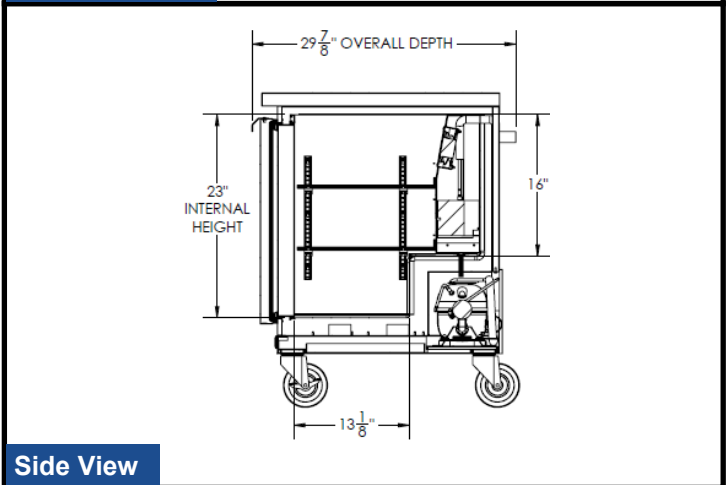

Side View

### ELECTRICAL CONNECTION



115/60/1  
NEMA-5-15P

Units pre-wired at factory and include 8' long cord and plug set.



an Ali Group Company



The Spirit of Excellence

3779 Champion Blvd., Winston-Salem, NC 27105  
1-888-845-9800 Fax: 1-336-245-6453  
Beverage-Air.com sales@bevair.com