



BEVERAGE-AIR

Project: _____

AIA#

Item: _____

Location: _____

SIS#

Approved: _____

WTR 29" DEPTH WORKTOP

WTR24AHC Solid Door Worktop Refrigerators
Hydrocarbon Series

MODELS:
WTR24AHC

WTR24AHC 29" Depth Worktop: Food Prep Series



WTR24AHC

3 Year Parts/Labor Warranty
Additional 2 Year Compressor Warranty

CABINET CONSTRUCTION

- Stainless steel front, sides and door, (*galvanized steel back & bottom*)
- Interior liner is made of corrosion resistant aluminum
- Stainless steel worktop
- 4" Removable backsplash for flexibility and ease of cleaning
- Full electronic control
- Interior thermometer is standard
- Self-closing doors with 120° stay-open feature, on cartridge style hinges
- Easy door removal for service and cleaning
- Magnetic gasket attached to each door for positive seal
- Painted aluminum door handle
- 6" Casters, two (2) with brakes standard
- Two epoxy-coated steel wire shelves standard
- Field reversible door
- Operates at 36° -38°F for optimum food preservation

OPTIONS & ACCESSORIES

- Stainless steel back and grille.
- Stainless steel interior available
- Glass door models available
- Solid door with lock
- 6" Legs
- 3" Casters
- Low profile casters
- Foot pedal door opener
- Remote option

REFRIGERATION SYSTEM

- Refrigeration system uses R290 refrigerant to comply with all environmental concerns
- Automatic, non-electric evaporator
- System is serviceable from rear
- Epoxy coated evaporator coil



3779 Champion Blvd., Winston-Salem, NC 27105
1-888-845-9800 Fax: 1-336-245-6453
Beverage-Air.com sales@bevair.com



BEVERAGE-AIR

MODEL	WTR24AHC
EXTERNAL DIMENSIONAL DATA	
Width Overall	24"
Depth Overall with Handle & Bumper	32"
Height Overall with 6" Casters	39 5/8"
Number of Doors	1
Depth with Door Open 90°	52 1/4"
Door Opening (in)	19 5/8" x 21 5/8"
Shelf Area (sq. in)	Upper 332 1/2" Lower 275 1/2"
INTERNAL DIMENSIONAL DATA	
NET Capacity (cubic ft.)	5.46
Internal Width Overall (in)	20"
Internal Depth Overall (in)	23 1/2"
Internal Depth Useable (in)	Upper 18 1/2" Lower 15 3/8"
Internal Height Front (in)	23"
Internal Height Rear (in)	16"
Number of Shelves	2
ELECTRICAL DATA	
Full Load Amperes 115/60/1	2
REFRIGERATION DATA	
Horsepower	1/6
Capacity (BTU/Hr)*	1010
WEIGHT DATA	
Gross Weight	168 lbs
Height - Crated	41"
Width - Crated	30"
Depth - Crated	32"

Worktop Refrigerator - 29" Depth

Models: WTR24AHC

Model Views

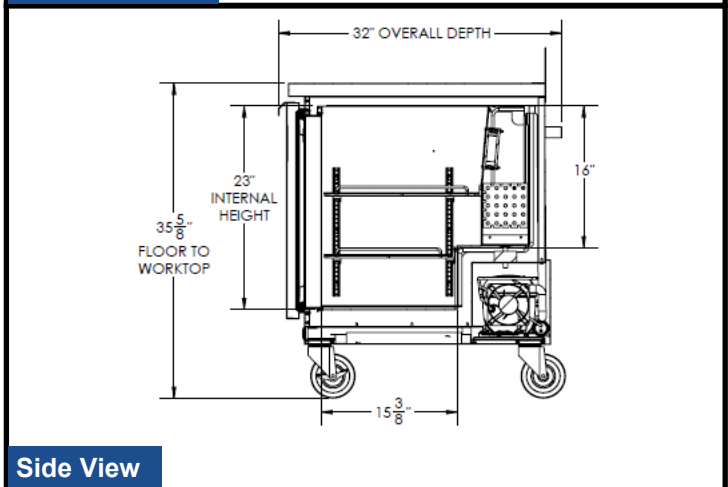
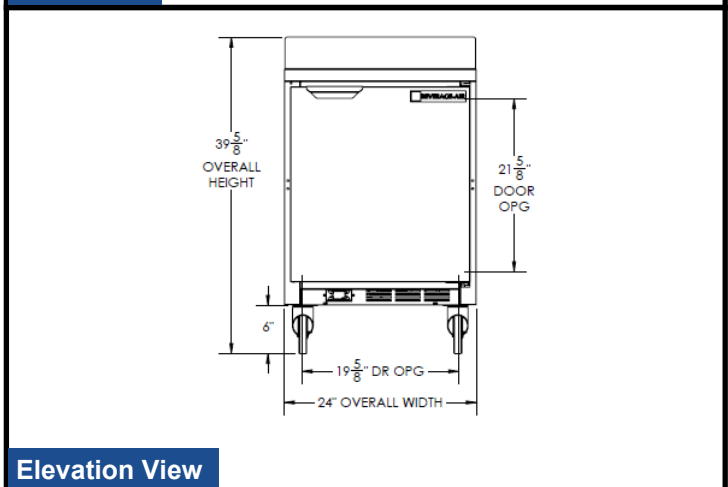
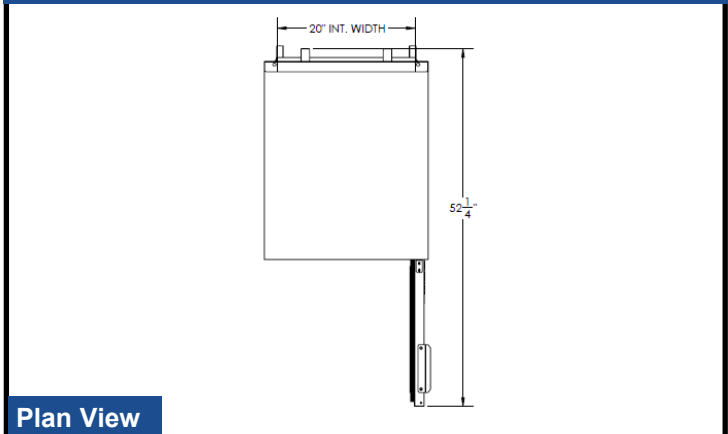

ELECTRICAL CONNECTION



115/60/1
NEMA-5-15P

Units pre-wired at factory and include 8' long cord and plug set.



an Ali Group Company



The Spirit of Excellence

3779 Champion Blvd., Winston-Salem, NC 27105
1-888-845-9800 Fax: 1-336-245-6453
Beverage-Air.com sales@bevair.com