



BEVERAGE-AIR

Project: _____	AIA#
Item: _____	SIS#
Location: _____	
Approved: _____	

WTFD FREEZER WITH DRAWERS

WTFD48AHC Four Drawer Worktop Freezer
Hydrocarbon Series

MODELS:
WTFD48AHC-4

3 Year Parts/Labor Warranty
Additional 2 Year Compressor Warranty

CABINET CONSTRUCTION



WTFD48AHC-4

- Stainless steel front, sides and drawers (*galvanized back & bottom*)
- Interior liner is made of corrosion resistant aluminum
- Stainless steel worktop for added durability
- Full electronic control
- Interior thermometer is standard
- 4" Removable backsplash for flexibility and ease of cleaning
- Painted aluminum drawer handles
- Snap-in drawer gaskets
- Upper and lower pull-out drawers accommodate 6" deep pans
- Stainless steel drawer frames supported on telescoping drawer slides
- Drawer slides include locking mechanism that prevents drawer from being inadvertently pulled off cabinet
- 6" Casters, two (2) with brakes standard
- Freezer model temperature is held at 0°F and below

OPTIONS & ACCESSORIES

- Stainless steel back and grille
- Stainless steel interior available
- Combination models available
- 6" Legs
- 3" Casters
- Low profile casters
- Food service pans
- Cutting board
- Remote option

REFRIGERATION SYSTEM

- Refrigeration system uses R290 refrigerant to comply with all environmental concerns
- Automatic, non-electric evaporator
- System is serviceable from rear
- Epoxy coated evaporator coil

WTFD48AHC-4 Freezer with Drawers: Worktop Series



3779 Champion Blvd., Winston-Salem, NC 27105
1-888-845-9800 Fax: 1-336-245-6453
Beverage-Air.com sales@bevaair.com



BEVERAGE-AIR

MODEL	WTFD48AHC-4
EXTERNAL DIMENSIONAL DATA	
Width Overall	48"
Depth Overall with Handle & Bumper	31 7/8"
Height Overall with 6" Casters	39 5/8"
Number of Drawers	4
Depth with Drawer Extended	47 7/8"
Drawer Opening (in)	Upper 19 5/8" x 11 1/4" Lower 19 5/8" x 7 1/2"
INTERNAL DIMENSIONAL DATA	
NET Capacity (cubic ft.)	11.6
Internal Width Overall (in)	44"
Internal Depth Overall (in)	23 1/2"
Internal Depth Useable (in)	Upper 18 1/2" Lower 15 3/8"
Internal Height Overall (in)	23"
ELECTRICAL DATA	
Full Load Amperes 115/60/1	7
REFRIGERATION DATA	
Horsepower	1/2
Capacity (BTU/Hr)*	1861
WEIGHT DATA	
Gross Weight (Crated lbs)	356 lbs
Height - Crated	35"
Width - Crated	51"
Depth - Crated	33"

Worktop Freezer – With Drawers

Models: WTFD48AHC-4

Model Views

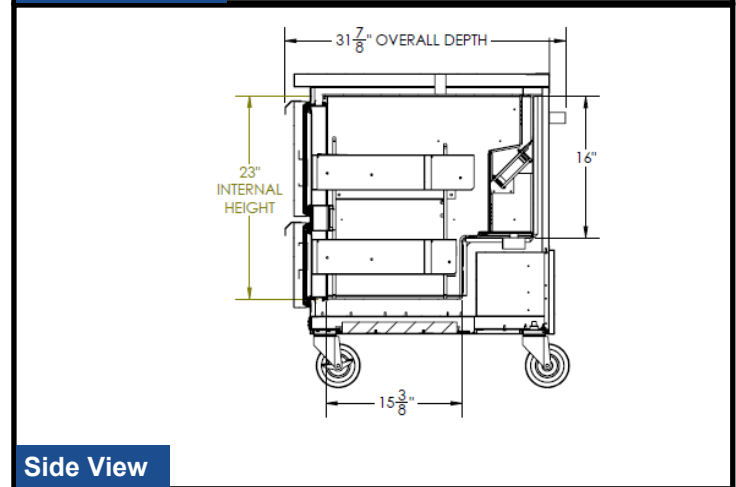
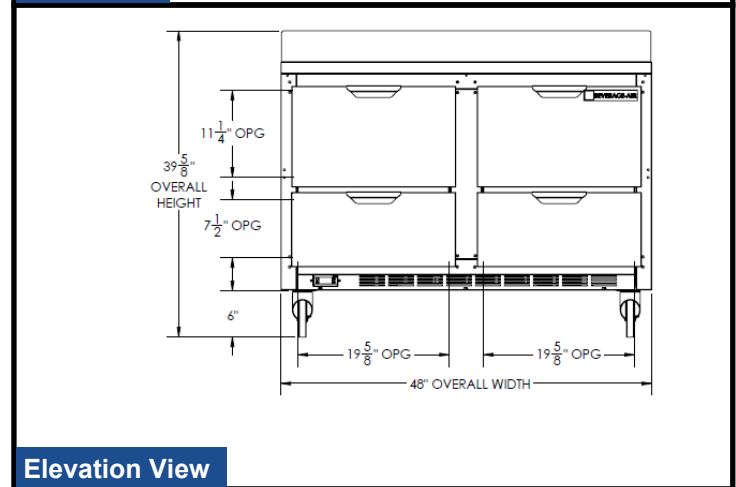
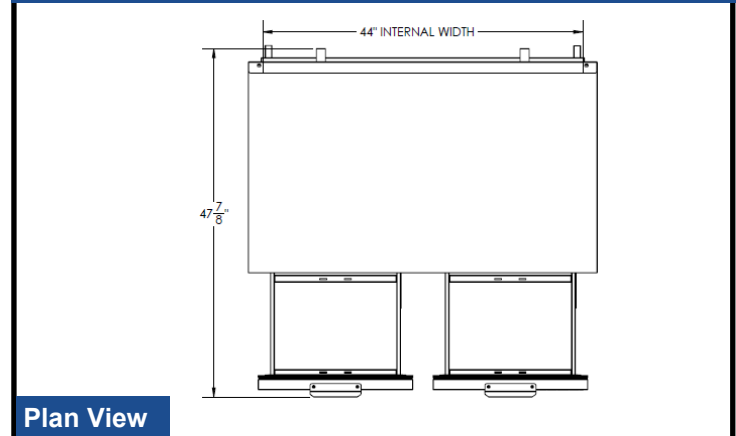

ELECTRICAL CONNECTION



115/60/1
NEMA-5-15P

Units pre-wired at factory and include 8' long cord and plug set.



an Ali Group Company



The Spirit of Excellence

3779 Champion Blvd., Winston-Salem, NC 27105
1-888-845-9800 Fax: 1-336-245-6453
Beverage-Air.com sales@bevair.com