



BEVERAGE-AIR

Project: _____

AIA#

Item: _____

Location: _____

SIS#

Approved: _____

WTF SHALLOW DEPTH WORKTOP

WTF27HC Solid Door Worktop Freezer

Hydrocarbon Series

MODELS:
WTF27HC

WTF27HC Shallow Depth Worktop: Food Prep Series

3 Year Parts/Labor Warranty
Additional 2 Year Compressor Warranty

CABINET CONSTRUCTION

- Stainless steel front, sides and door, *(galvanized back & bottom)*
- Interior liner is made of corrosion resistant aluminum
- Stainless steel top for added durability
- Full electronic control
- Interior thermometer is standard
- 4" Removable backsplash for flexibility and ease of cleaning
- Self-closing doors with 120° stay-open feature, on cartridge style hinges
- Door opening includes low wattage, anti-condensate heaters
- Easy door removal for service and cleaning
- Magnetic gasket attached to each door for positive seal
- Painted aluminum door handle
- 6" Casters, two (2) with brakes standard
- Two epoxy-coated steel wire shelves standard
- Field-reversible door
- Freezer temperature operates at 0°F and below

REFRIGERATION SYSTEM

- Refrigeration system uses R290 refrigerant to comply with all environmental concerns
- Automatic, non-electric evaporator
- System is serviceable from rear
- Epoxy coated evaporator coil



WTF27HC

OPTIONS & ACCESSORIES

- Stainless steel back and grille
- Stainless steel interior available
- Glass door option
- Drawer unit available
- Cutting board option
- 6" Legs
- 3" Casters
- Low profile casters
- Foot pedal door opener
- Remote option



3779 Champion Blvd., Winston-Salem, NC 27105
1-888-845-9800 Fax: 1-336-245-6453
Beverage-Air.com sales@bevair.com



BEVERAGE-AIR

Worktop Freezer - Shallow Depth Models: WTF27HC

MODEL	WTF27HC
EXTERNAL DIMENSIONAL DATA	
Width Overall	27"
Depth Overall with Handle & Bumper	29 7/8"
Height Overall with 6" Casters	39 5/8"
Number of Doors	1
Depth with Door Open 90°	53 1/8"
Door Opening (in)	22 5/8" x 21 5/8"
INTERNAL DIMENSIONAL DATA	
NET Capacity (cubic ft.)	5.49
Internal Width Overall (in)	23"
Internal Depth Overall (in)	21 1/4"
Internal Depth Useable (in)	Upper 16" Lower 13 1/8"
Internal Height Front (in)	23"
Internal Height Rear (in)	16"
Number of Shelves	2
ELECTRICAL DATA	
Full Load Amperes 115/60/1	2.5
REFRIGERATION DATA	
Horsepower	1/3
Capacity (BTU/Hr)*	857
WEIGHT DATA	
Gross Weight (Crated lbs)	185 lbs
Height - Crated	43 1/2"
Width - Crated	30"
Depth - Crated	32 1/4"

Model Views

Plan View

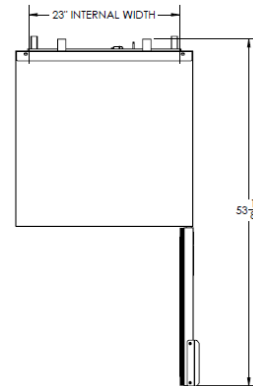

Elevation View

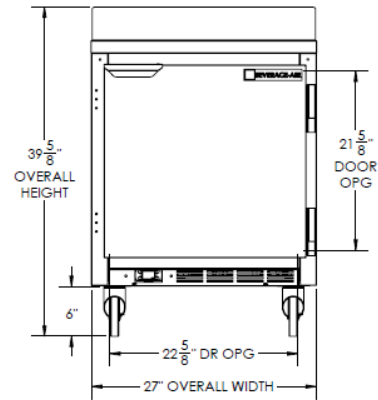

Side View

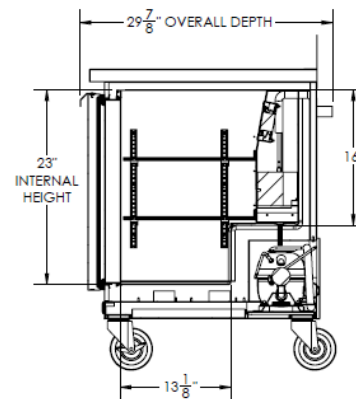

ELECTRICAL CONNECTION



115/60/1
NEMA-5-15P

Units pre-wired at factory and include 8' long cord and plug set.



an Ali Group Company



The Spirit of Excellence

3779 Champion Blvd., Winston-Salem, NC 27105
1-888-845-9800 Fax: 1-336-245-6453
Beverage-Air.com sales@bevair.com