



# BEVERAGE-AIR

Project: \_\_\_\_\_

AIA#

Item: \_\_\_\_\_

Location: \_\_\_\_\_

SIS#

Approved: \_\_\_\_\_

## WTF 29" DEPTH WORKTOP

### WTF24AHC Solid Door Worktop Freezer

### Hydrocarbon Series

**MODELS:**

**WTF24AHC**



**WTF24AHC**

**3 Year Parts/Labor Warranty**  
**Additional 2 Year Compressor Warranty**

### CABINET CONSTRUCTION

- Stainless steel front, sides and door, *(galvanized back & bottom)*
- Interior liner is made of corrosion resistant aluminum
- Stainless steel top for added durability
- Full electronic control
- Interior thermometer is standard
- 4" Removable backsplash for flexibility and ease of cleaning
- Self-closing doors with 120° stay-open feature, on cartridge style hinges
- Door opening includes low wattage, anti-condensate heaters
- Easy door removal for service and cleaning
- Magnetic gasket attached to each door for positive seal
- Painted aluminum door handle
- 6" Casters, two (2) with brakes standard
- Two epoxy-coated steel wire shelves standard
- Field-reversible door
- Freezer temperature operates at 0°F and below

### OPTIONS & ACCESSORIES

- Stainless steel back and grille
- Stainless steel interior available
- Glass door models available
- Solid door with lock
- 6" Legs
- 3" Casters
- Low profile casters
- Foot pedal door opener
- Remote option

### REFRIGERATION SYSTEM

- Refrigeration system uses R290 refrigerant to comply with all environmental concerns
- Automatic, non-electric evaporator
- System is serviceable from rear
- Epoxy coated evaporator coil

WTF24AHC 29" Depth Worktop: Worktop Series



3779 Champion Blvd., Winston-Salem, NC 27105  
1-888-845-9800 Fax: 1-336-245-6453  
Beverage-Air.com sales@bevair.com



# BEVERAGE-AIR

| MODEL                              | WTF24AHC                         |
|------------------------------------|----------------------------------|
| <b>EXTERNAL DIMENSIONAL DATA</b>   |                                  |
| Width Overall                      | 24"                              |
| Depth Overall with Handle & Bumper | 32"                              |
| Height Overall with 6" Casters     | 39 5/8"                          |
| Number of Doors                    | 1                                |
| Depth with Door Open 90°           | 52 1/4"                          |
| Door Opening (in)                  | 19 5/8" x 21 5/8"                |
| Shelf Area (sq. in)                | Upper 332 1/2"<br>Lower 275 1/2" |
| <b>INTERNAL DIMENSIONAL DATA</b>   |                                  |
| NET Capacity (cubic ft.)           | 5.38                             |
| Internal Width Overall (in)        | 20"                              |
| Internal Depth Overall (in)        | 23 1/2"                          |
| Internal Depth Useable (in)        | Upper 18 1/2"<br>Lower 15 3/8"   |
| Internal Height Front (in)         | 23"                              |
| Internal Height Rear (in)          | 16"                              |
| Number of Shelves                  | 2                                |
| <b>ELECTRICAL DATA</b>             |                                  |
| Full Load Amperes 115/60/1         | 2.5                              |
| <b>REFRIGERATION DATA</b>          |                                  |
| Horsepower                         | 1/3                              |
| Capacity (BTU/Hr)*                 | 857                              |
| <b>WEIGHT DATA</b>                 |                                  |
| Gross Weight                       | 190 lbs                          |
| Height - Crated                    | 43"                              |
| Width - Crated                     | 41"                              |
| Depth - Crated                     | 32"                              |

## Worktop Freezer - 29" Depth

Models: WTF24AHC

### Model Views

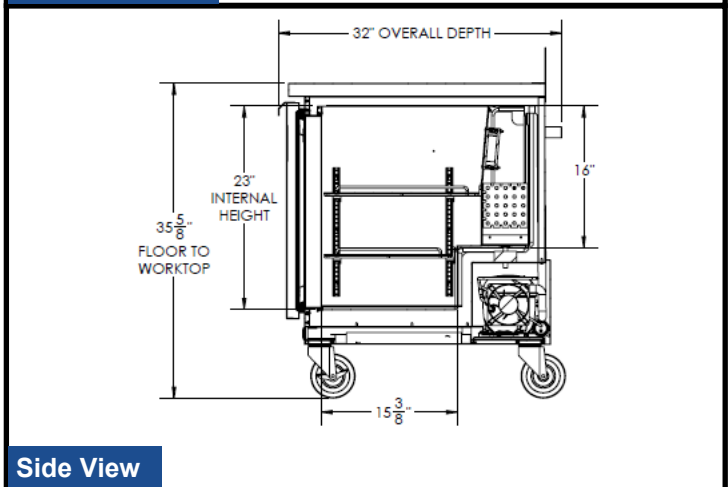
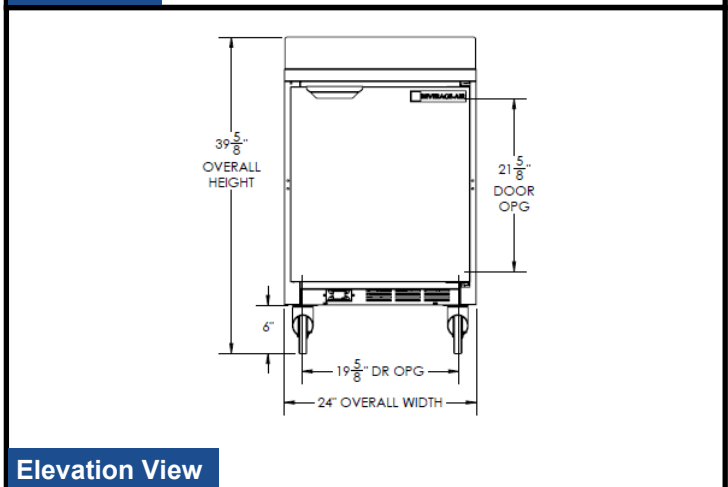
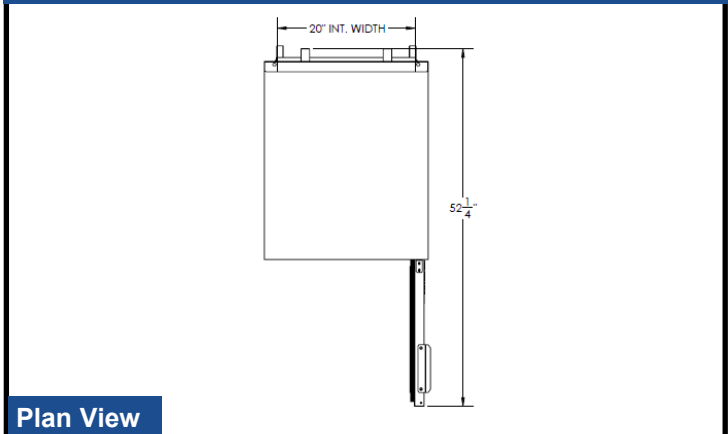

### ELECTRICAL CONNECTION



115/60/1  
NEMA-5-15P

Units pre-wired at factory and include 8' long cord and plug set.



an Ali Group Company



The Spirit of Excellence

3779 Champion Blvd., Winston-Salem, NC 27105  
1-888-845-9800 Fax: 1-336-245-6453  
Beverage-Air.com sales@bevair.com