



BEVERAGE-AIR

Project: _____	AIA#
Item: _____	SIS#
Location: _____	
Approved: _____	

UCRF DUAL-TEMP UNDERCOUNTER

UCRF48A Undercounter Freezer/Refrigerator

MODELS:
UCRF48A1-SA-A
UCRF48A1-SA-B



UCRF48A1-SA

3 Year Parts/Labor Warranty
Additional 2 Year Compressor Warranty

CABINET CONSTRUCTION

- Stainless steel front, sides, doors, and grille (*galvanized back & bottom*)
- Interior liner is made of corrosion resistant aluminum
- Dual Temp: left side freezer, right side refrigerator units provide two different operating temperature zones for different types of products
- Full electronic control
- Undercounter feature a 1/2" thick sub-top
- Interior thermometer is standard
- Self-closing doors with 120° stay-open feature, on cartridge style hinges
- Easy door removal for service and cleaning
- Magnetic gasket attached to each door for positive seal
- Painted aluminum door handles
- 6" Casters, two (2) with brakes standard
- Four (4) epoxy-coated steel wire shelves standard
- Field reversible doors
- Refrigerator maintains product temperatures between 36°F and 38°F
- Freezer maintains product temperature from 0°F and below

OPTIONS & ACCESSORIES

- Stainless steel back and grille
- Stainless steel interior
- Right or left hinged door
- Locks (solid doors only)
- Bun rack
- Wire shelf divider
- Thermometer digital or stem type dial
- 3" Casters or 6" legs
- Low profile casters
- Remote option

REFRIGERATION SYSTEM

- Freezer: Refrigeration system uses R404A refrigerant to comply with all environmental concerns
- Automatic, electric defrost
- Refrigerator: Refrigeration system uses R134A refrigerant to comply with all environmental concerns
- Automatic, non-electric defrost
- Epoxy coated evaporator coil

UCRF48A Undercounter Freezer/Refrigerator: Food Prep Series



3779 Champion Blvd., Winston-Salem, NC 27105
 1-888-845-9800 Fax: 1-336-245-6453
 Beverage-Air.com sales@bevair.com



BEVERAGE-AIR

MODEL	UCRF48A-1-SA
EXTERNAL DIMENSIONAL	
Width Overall	48"
Depth Overall	32"
Height Overall with 6" casters	34 1/2"
Number of Doors	2
Depth with Door Open 90°	52 1/4"
Door Opening (in)	19 1/2" x 21 5/8"
INTERNAL DIMENSIONAL	
NET Capacity (cubic ft.) Refrigerator	5.31
NET Capacity (cubic ft.) Freezer	5.31
Internal Width Overall (in)	21"
Internal Depth Overall (in)	15 3/8"
Internal Height Overall (in)	23"
Number of Shelves	4
ELECTRICAL DATA	
Full Load Amperes Refrigerator 115/60/1	4.0
Full Load Amperes Freezer 115/60/1	5.5
REFRIGERATION DATA	
Horsepower Refrigerator	1/4
Horsepower Freezer	1/2
Capacity (BTU/Hr)* Refrigerator	848
Capacity (BTU/Hr)* Freezer	739
WEIGHT DATA	
Gross Weight (Crated lbs)	297 lbs
Height - Crated	36"
Width - Crated	51"
Depth - Crated	32"

Undercounter Dual Temp Freezer/Refrigerator

Models: UCRF48A-1-SA-A, UCRF48A1-SA-B

Model Views

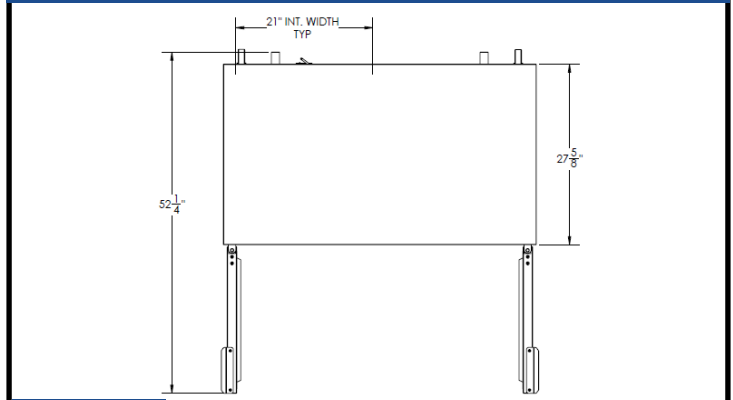

Plan View

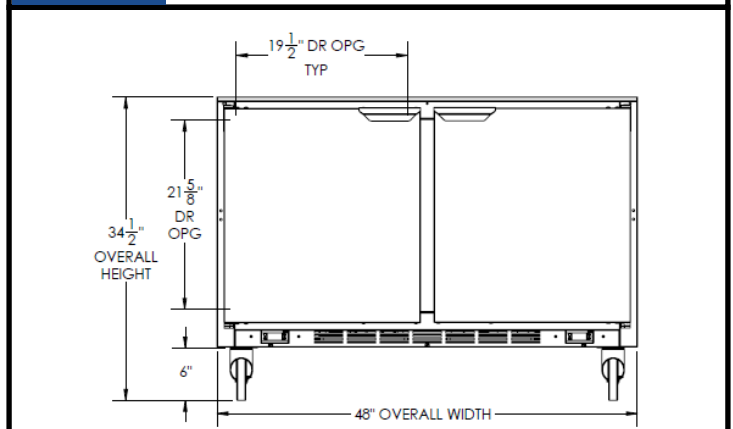

Elevation View

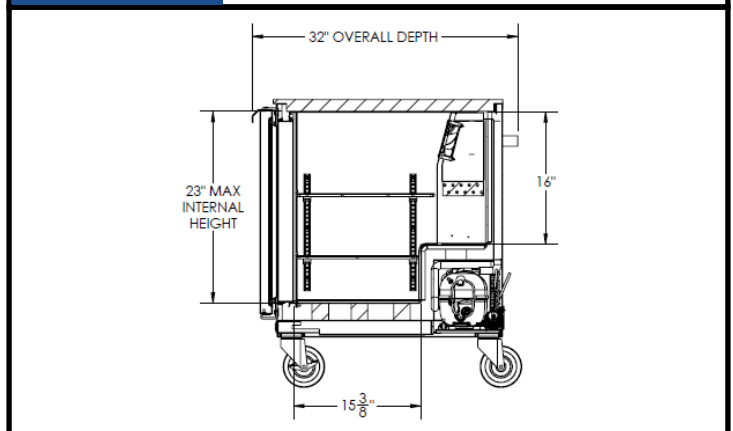

Side View

FLEXIBLE DOOR CONFIGURATIONS

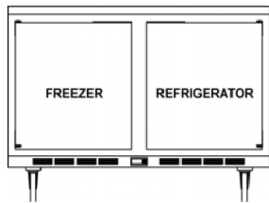

UCRF48A-1-SA-A

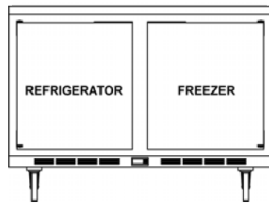

UCRF48A-1-SA-B

ELECTRICAL CONNECTION



115/60/1
NEMA-5-15P

Units pre-wired at factory and include 8' long cord and plug set.



an Ali Group Company



The Spirit of Excellence

3779 Champion Blvd., Winston-Salem, NC 27105
1-888-845-9800 Fax: 1-336-245-6453
Beverage-Air.com sales@bevair.com