



TC 32 CALIFORNIA

*tritacarne
meat grinders*



- Tritacarne solido, robusto e performante adatto a piccoli laboratori, collettività, mense e grandi cucine.
- Dotato di gambe e ruote in acciaio inox con freno per una sicura stabilità e grande praticità.
- Corpo macchina totalmente in acciaio inox AISI 304.
- Grande tramoggia di carico 410x610x76 mm con micro per una maggior sicurezza.
- Potenti motori IP 55 autoventilati per uso continuo.
- Riduttore a bagno d'olio con ingranaggi rettificati.
- Riduttore con doppio sistema di protezione dai liquidi.
- Rapido fissaggio bocca senza utensili.
- Gruppo macinazione completamente in acciaio inox facilmente e totalmente smontabile per pulizia.
- Tramoggia rimovibile interbloccata (CE).
- Comandi inox, 24 Volt IP67.

Opzioni:

- Bocche Unger parziale o totale.
- *Heavy-duty meat grinder with high capacity, suitable for all kitchens.*
- *The machine is on stand with stainless steel casters and therefore very stable and easy to move.*
- *AISI 304 stainless steel construction.*
- *Large mm 410x610x76 feeding tray with safety microswitch.*
- *Powerful IP 55 insulated and fan-cooled motors for continuous use.*
- *Endless screw motor-reducer running in an oil-bath enables a long service life.*
- *Motor-reducer equipped with a double seal for long, trouble-free service.*
- *Head can be locked in with no tools.*
- *Stainless steel head with high output capacity, completely removable for cleaning.*
- *Feed tray provided with safety interlock CE versions.*
- *Stainless steel IP 67 protected, 24 V controls.*

Optionals:

- *Partial or total Unger system mincing head.*

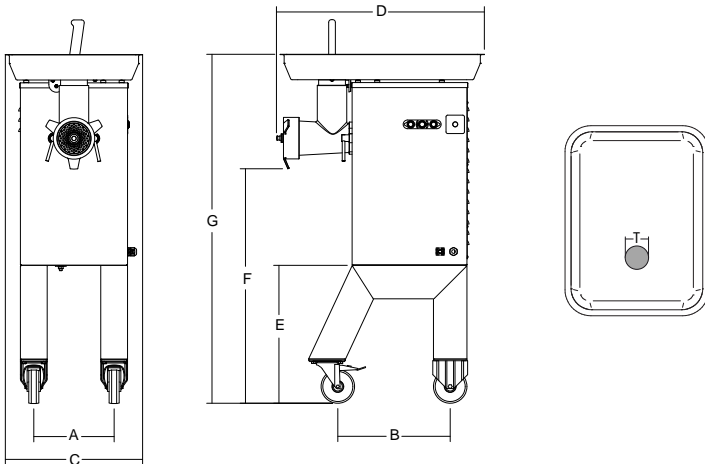

					A	B	C	D	E	F	G	T	KG		
	watt/Hp	3ph	kg/h.	ø mm	mm	mm	mm	mm	mm	mm	mm	mm	kg	mm	kg
TC 32 California	2.205/3		400	6	240	336	410	621	412	700	1042	77	55	720x570x1180	70



Standard/
enterprise

1/2
Unger

Unger
Totale