



## MODELS

KGL-IS-110-S

KGL-IS-110-R

## GRAB AND GO LOW PROFILE CASE ISLAND COMBINATION

CASE HOLDS 36°F TO 40°F • FORCED AIR REFRIGERATION • OPEN FRONT  
FRONT LOADING • LED LIGHTING IN CANOPY AND UNDER ALL SHELVES  
PULL DOWN NIGHT CURTAIN



Intertek



Intertek



AUTODESK®  
REVIT®

SELF CONTAINED	Model	Width (in)	Depth (in)	Front Capacity Cu.ft	Electrical 115 Volts / 220 Volts			NEMA Plug	Weight lbs		Crate Size (inches)		
					Compressor		Total Amps		Crated	Uncrated	L"	W"	H"
					H.P	F.L.A							
KGL-IS-110-S	112	78	52	2 x 5/8	2 x 8.9	2 x 17	HARD WIRED	2 x 507	2 x 357	2 x 43.8	2 x 34.5	67.8	
				2 x 1-1/4	9.2	2 x 14.1	HARD WIRED	2 x 1,015	2 x 714	2 x 87	2 x 34.5	67.8	

REMOTE	Model	Width (in)	Depth (in)	B.T.U	115 Volts Total Amps	Nema Plug	Weight lbs	
							Crated	Uncrated
KGL-IS-110-R	112	78	2 x 4125	2 x 0.4	HARD WIRED	2 x 441	2 x 291	
								2 x 8000

**This unit is a combination of 4 units:**  
**(2) KGL-OF-40**  
**(2) KGL-OF-70**

**STANDARD FEATURES**

- Silver colored PVC coated steel front panel
- Special ducts to remove hot air from the condensing units
- Pull down night curtain
- CFC free injected foam insulation
- PVC coated steel gray interior
- Black steel kick plate
- Foamed polystyrene black end panels
- Tempered side glass
- Height adjustable shelves can be tilted
- Products stop on shelves
- Temperature and defrost regulated by a digital controller
- Digital thermometer
- Slide out condensing unit on self-contained units
- Removable condensate evaporating pan for easy cleaning c
- Cord and plug
- Leveling feet

**OPTIONAL FEATURES**

- Stainless steel exterior and / or interior
- Other colors available
- Extra shelves optional with LED
- Additional shelves
- Price tag molding
- Joining kit
- Partition or product dividers
- Condensate evaporating pan for remote cases
- Casters-add 4-3/8" to height
- Stainless steel legs are adjustable from 5-1/8" to 7-5/8"

**WARRANTY**

One year parts and labor with an additional four years on the compressor (part only)

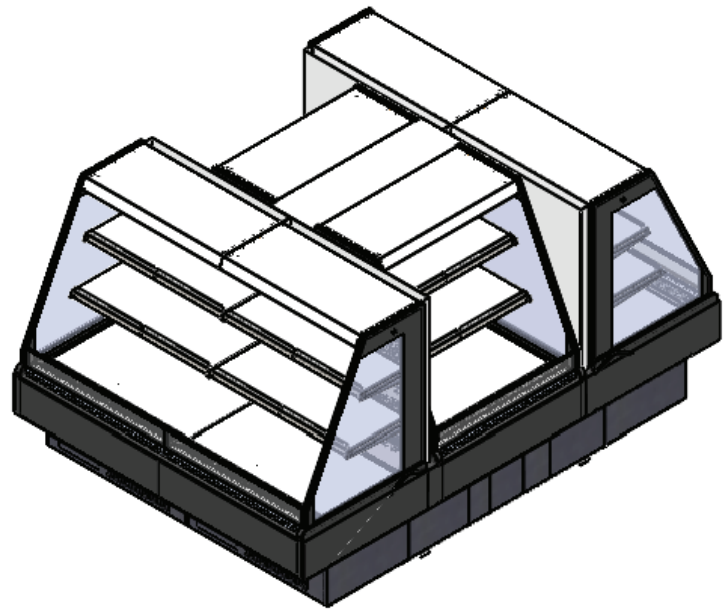

Standard Mounting



Levelling Feet

Optional Mounting



Adjustable Legs

Casters

**NOTE**

These cases are engineered to operate in locations not exceeding 75°F and 55% R.H. These cases are designed to operate using R452a refrigerant. Alternate refrigerants available by special order. O.A. length includes (2) ends at 1-1/2" each. Ventilation grills at front and back cannot be blocked. B.T.U.'s are calculated at 14°F (evaporator) and 90°F (ambient). Remote cases are provided with an expansion valve and a liquid solenoid for pump down cycle. On remote cases, if no floor drain is provided, a condensate evaporating pan must be ordered and 6.7 amps added to the amp load. Remote cases must be hard wired – no plugs.



3560 NW 56th St  
 Fort Lauderdale, FL USA 33309  
 Tel: 786.600.4687 / Toll Free: 844.218.8477 / Fax: 786.661.4100



5659 Royalmount Ave.  
 Montreal, QC, Canada H4P 2P9  
 Tel: 514.737.9701 / Toll Free: 888.275.4538 / Fax: 514.342.3854  
 Toll free: 877.453.8832  
 sales@mvpgroupcorp.com / mvpgroupcorp.com



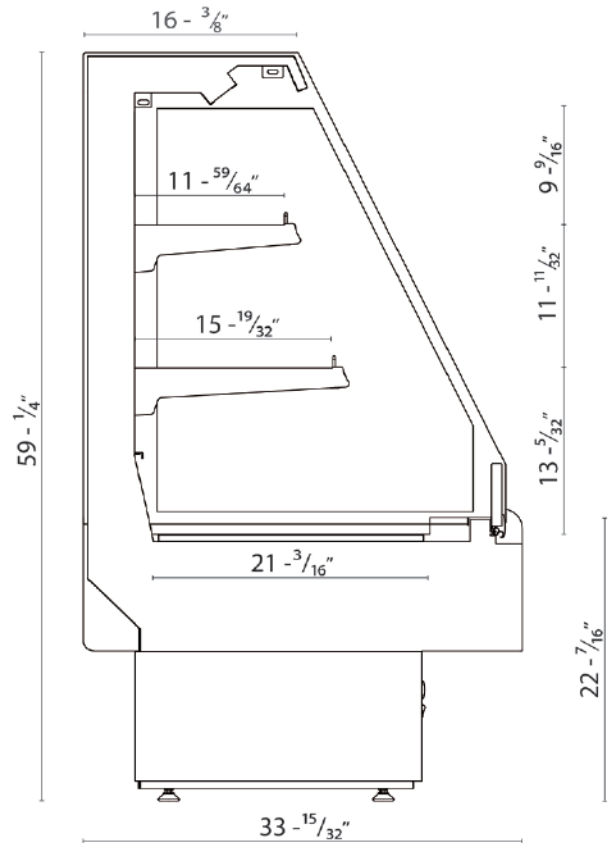
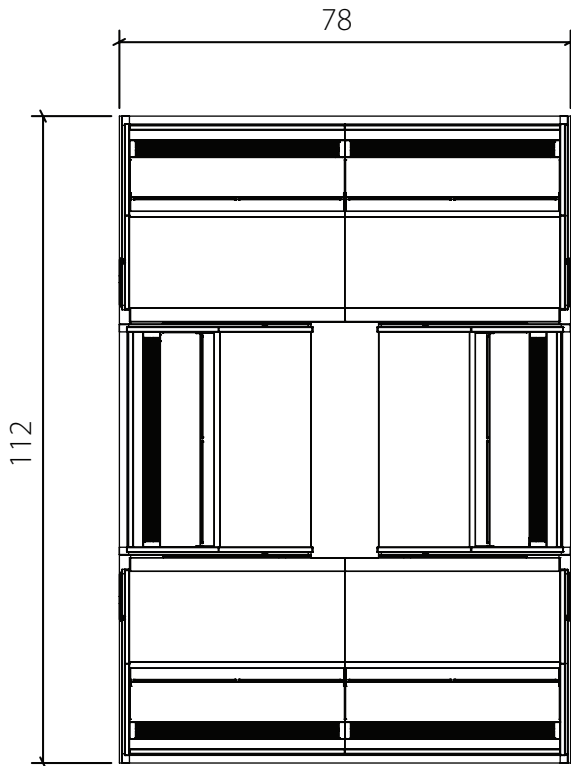
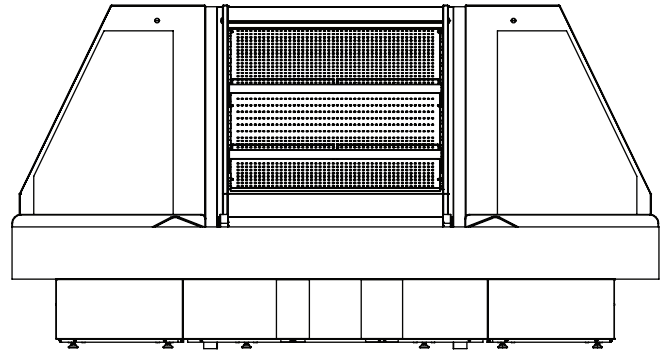
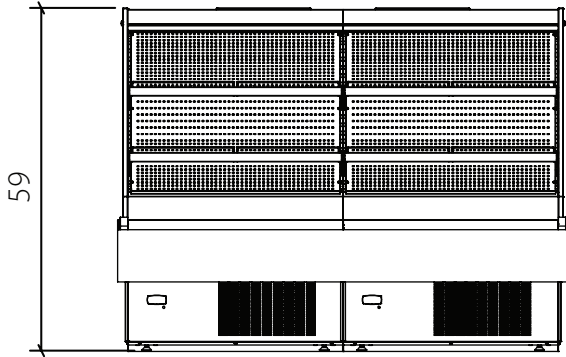

**This unit is a combination of 4 units:**  
**(2) KGL-OF-40**  
**(2) KGL-OF-70**



3560 NW 56th St  
 Fort Lauderdale, FL USA 33309  
 Tel: 786.600.4687 / Toll Free: 844.218.8477 / Fax: 786.661.4100



5659 Royalmount Ave.  
 Montreal, QC, Canada H4P 2P9  
 Tel: 514.737.9701 / Toll Free: 888.275.4538 / Fax: 514.342.3854  
 Toll free: 877.453.8832  
[sales@mvpgroupcorp.com](mailto:sales@mvpgroupcorp.com) / [mvpgroupcorp.com](http://mvpgroupcorp.com)



Hydra - Kool is a registered trademark of MVP Group Corp.  
 SPECIFICATIONS SUBJECT TO CHANGE WITHOUT NOTICE