



MODELS

KBD-FG-(40, 50, 60, 80)-S

KBD-FG-(40, 50, 60, 80)-R

KBD-FG-(40, 50, 60, 80)-D

FLAT GLASS BAKERY DELI CASE

CASE HOLDS 36°F TO 40°F • FORCED AIR REFRIGERATION
TEMPERED GLASS FRONT, SIDE AND REAR SLIDING DOORS
LED LIGHTING IN CANOPY AND UNDER ALL SHELVES
CASES CAN BE MULTIPLEXED



Intertek



Intertek



AUTODESK[®]
REVIT[®]

SELF CONTAINED	Model	O.A. Length (inches)	Volume FT ³	Electrical 115 Volts					NEMA 115 V Plug	Weight lbs		Crate Size (inches)		
				Front	Compressor		LIGHTS Fans HTRS	EVAP Pan		Total Amps	No Crate	With Crate	L"	W"
			H.P		F.L.A									
	KBD-FG-40-S	40.4	15.55	3/8	8.4	1.4	3.3	13.2	5-15P	397	543	43.4	34.5	62.3
	KBD-FG-50-S	52.2	20.49	1/2	9.6	1.6	3.3	14.6	5-20P	461	638	55.2	34.5	62.3
	KBD-FG-60-S	60	23.78	1/2	9.6	1.8	3.3	14.8	5-20P	505	703	63	34.5	62.3
	KBD-FG-80-S	77.5	31.1	1/2	9.6	2.65	3.3	15.6	5-20P	588	823	80.5	34.5	62.3

REMOTE	Model	O.A. Length (inches)	115 Volts Total Amps	B.T.U	Weight lbs	
					No Crate	With Crate
					KBD-FG-40-R	40.4
KBD-FG-50-R	52.2	1.19	3110	403	580	
KBD-FG-60-R	60	1.36	3268	447	645	
KBD-FG-80-R	77.5	2.2	3987	530	773	

NON-REFRIGERATED	Model	O.A. Length (inches)	115 Volts Total Amps	NEMA 115 V Plug	Weight lbs	
					No Crate	With Crate
					KBD-FG-40-D	40.4
KBD-FG-50-D	52.2	0.33	5-15P	381	549	
KBD-FG-60-D	60	0.41	5-15P	423	611	
KBD-FG-80-D	77.5	0.46	5-15P	530	773	

STANDARD FEATURES

- Silver colored PVC coated steel front panel
- CFC free injected foam insulation
- PVC coated steel gray interior
- Black steel kick plate
- Foamed polystyrene black end panels
- Removable rear tempered glass sliding door
- Height adjustable, tempered glass shelves can be tilted
- Temperature and defrost regulated by a digital controller
- Removable condensate evaporating pan for easy cleaning on self contained units
- Digital temperature display
- Anti-condensate system for front glass
- Cord and plug on self-contained and dry units
- Levelling feet

OPTIONAL FEATURES

- Stainless steel exterior and / or interior
- Other colors available
- Additional shelves
- Joining kit
- Partition or product dividers
- Scale stand with 120 V receptacle
- Condensate evaporating pan for remote cases
- Casters-add 4-3/8" to height
- Stainless steel legs are adjustable from 5-1/8" to 7-5/8"

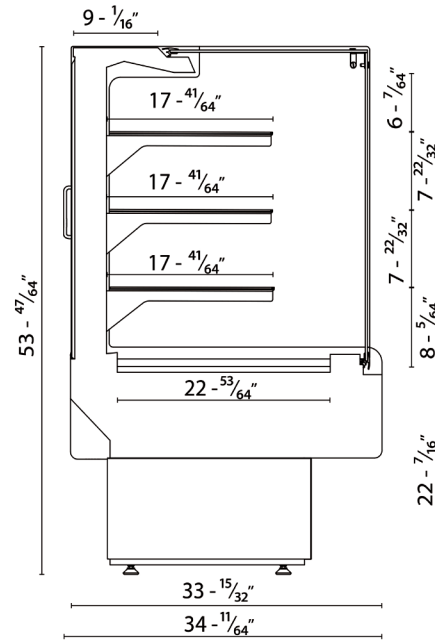

NOTE

These cases are engineered to operate in locations not exceeding 75°F and 55% R.H. These cases are designed to operate using R452a refrigerant. Alternate refrigerants available by special order. O.A. length includes (2) ends at 1-1/2" each. Ventilation grills at front and back cannot be blocked. B.T.U.'s are calculated at 14°F (evaporator) and 90°F (ambient). Remote cases are provided with an expansion valve and a liquid solenoid for pump down cycle. On remote cases, if no floor drain is provided, a condensate evaporating pan must be ordered and 3.3 amps added to the amp load. Remote cases must be hard wired – no plugs.



3560 NW 56th St
Fort Lauderdale, FL USA 33309
Tel: 786.600.4687 / Toll Free: 844.218.8477 / Fax: 786.661.4100



5659 Royalmount Ave.
Montreal, QC, Canada H4P 2P9
Tel: 514.737.9701 / Toll Free: 888.275.4538 / Fax: 514.342.3854
Toll free: 877.453.8832
sales@mvpgroupcorp.com / mvpgroupcorp.com

