



TILT OUT FRONT GLASS

MODELS

KBD-CG-(40, 50, 60, 80)-S
KBD-CG-(40, 50, 60, 80)-R
KBD-CG-(40, 50, 60, 80)-D

CURVED GLASS BAKERY DELI CASE

CASE HOLDS 36°F TO 40°F • FORCED AIR REFRIGERATION • TEMPERED TILT-OUT CURVED FRONT GLASS • TEMPERED SIDE GLASS AND REAR SLIDING DOORS
LED LIGHTING IN CANOPY AND UNDER ALL SHELVES
CASES CAN BE MULTIPLEXED



AUTODESK®
REVIT®

SELF CONTAINED	Model	O.A. Length (inches)	Volume FT ³	Electrical 115 Volts					NEMA 115 V Plug	Weight lbs		Crate Size (inches)			
				Front	Compressor		LIGHTS Fans HTRS	EVAP Pan		Total Amps	No Crate	With Crate	L"	W"	H"
					H.P	F.L.A									
	KBD-CG-40-S	40.4	13.28	3/8	8.4	1.3	3.3	13.0	5-15P	375	514	43.04	34.5	62.3	
	KBD-CG-50-S	52.2	17.50	1/2	9.6	1.5	3.3	14.4	5-20P	436	604	55.02	34.5	62.3	
	KBD-CG-60-S	60	20.31	1/2	9.6	1.6	3.3	14.5	5-20P	478	666	63	34.5	62.3	
	KBD-CG-80-S	77.5	26.56	1/2	9.6	2.7	3.3	15.6	5-20P	557	787	80.5	34.5	62.3	

REMOTE	Model	O.A. Length (inches)	115 Volts Total Amps	B.T.U	Weight lbs	
					No Crate	With Crate
					KBD-CG-40-R	40.4
KBD-CG-50-R	52.2	1.06	3110	381	549	
KBD-CG-60-R	60	1.10	3268	423	611	
KBD-CG-80-R	77.5	2.20	3987	502	732	

NON-REFRIGERATED	Model	O.A. Length (inches)	115 Volts Total Amps	NEMA 115 V Plug	Weight lbs	
					No Crate	With Crate
					KBD-CG-40-D	40.4
KBD-CG-50-D	52.6	0.33	5-15P	381	549	
KBD-CG-60-D	60	0.41	5-15P	423	611	
KBD-CG-80-D	77.5	0.46	5-15P	502	732	

STANDARD FEATURES

- Silver colored PVC coated steel front panel
- CFC free injected foam insulation
- PVC coated steel gray interior
- Black steel kick plate
- Foamed polystyrene black end panels
- Removable rear tempered glass sliding door
- Anti-condensate system for front glass
- Removable condensate evaporating pan for easy cleaning on self contained units
- Height adjustable, tempered glass shelves can be tilted
- Temperature and defrost regulated by a digital controller
- Digital temperature display
- Cord and plug on self-contained and dry units
- Leveling feet

OPTIONAL FEATURES

- Stainless steel exterior and / or interior
- Other colors available
- Additional shelves
- Joining kit
- Partition or product dividers
- Scale stand with 120 V receptacle
- Condensate evaporating pan for remote cases
- Casters-add 4-3/8" to height
- Stainless steel legs are adjustable from 5-1/8" to 7-5/8"

WARRANTY

One year parts and labor with an additional four years on the compressor (part only)

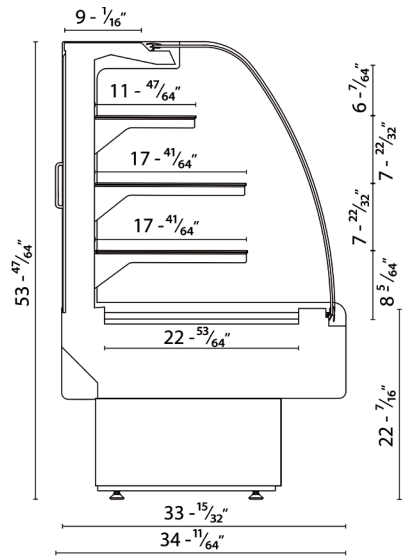

Standard Mounting

Optional Mounting



Levelling Feet



Adjustable Legs



Casters

NOTE

These cases are engineered to operate in locations not exceeding 75°F and 55% R.H. These cases are designed to operate using R452a refrigerant. Alternate refrigerants available by special order. O.A. length includes (2) ends at 1-1/2" each. Ventilation grills at front and back cannot be blocked. B.T.U.'s are calculated at 14°F (evaporator) and 90°F (ambient). Remote cases are provided with an expansion valve and a liquid solenoid for pump down cycle. On remote cases, if no floor drain is provided, a condensate evaporating pan must be ordered and 3.3 amps added to the amp load. Remote cases must be hard wired – no plugs.



3560 NW 56th St
Fort Lauderdale, FL USA 33309
Tel: 786.600.4687 / Toll Free: 844.218.8477 / Fax: 786.661.4100



5659 Royalmount Ave.
Montreal, QC, Canada H4P 2P9
Tel: 514.737.9701 / Toll Free: 888.275.4538 / Fax: 514.342.3854
Toll free: 877.453.8832
sales@mvpgroupcorp.com / mvpgroupcorp.com

