

Model Numbers

ITG-24
ITG-36
ITG-48
ITG-60
ITG-72

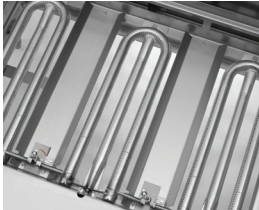

Aeration baffles between burners spread heat across the griddle plate for even heating.



Thick highly polished steel griddle plate maintains selected temperatures.



Full width rear flue distributes heat uniformly across the griddle surface.

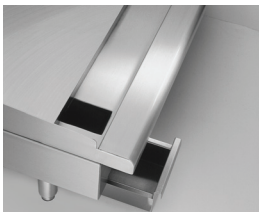

Stainless steel grease gutter and 1 gal. (3.8 L) grease can.



ITG-36

BURNERS - Thermostat maintains selected temperature during peak hours.

- Each griddle burner is rated at 30,000 BTU (9KW).
- Aeration baffles between burners spread the heat evenly across the entire griddle surface.
- Burners are located every 12" (305 mm).
- Each burner has an adjustable gas valve and continuous pilot for instant ignition.

GRIDDLE PLATE - Highly polished 1" (25 mm) thick steel plate holds temperature and has a quick recovery.

- Full 24" (610 mm) plate depth for more cooking surface.
- Surface is ideal for a large range of menu items.
- Optional chrome griddle top is available as an option.

GREASE MAINTENANCE - Stainless steel grease gutter is 4" (102 mm) wide.

- Large 1 gal (3.8 L) capacity grease can has a weep hole to indicate when full.
- 60" and 72" (1524 and 1829 mm) models include 2 grease cans.
- Grease can(s) removes easily.

EXTERIOR - Stainless steel front, sides, splash guard, and ledge.

- Stainless steel ledge is one piece rolled for cleaning convenience.
- Range match profile when placed on a refrigerated base or equipment stand.
- Control knobs are cast aluminum with a Valox™ heat protection grip.
- 4" (102 mm) stainless steel legs are included.
- One year parts and labor warranty.

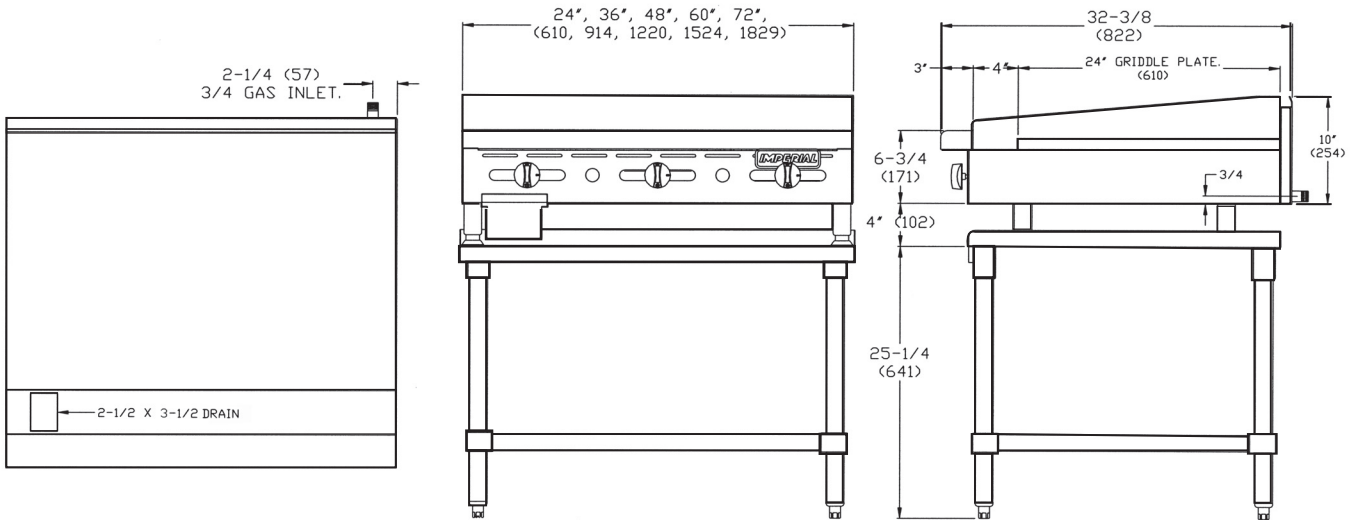

THERMOSTATIC CONTROLLED GRIDDLES

MODEL	WIDTH	NUMBER OF BURNERS	GAS OUTPUT		SHIP WEIGHT	
			BTU	(KW)	(KG)	LBS
ITG-24	24" (610 mm)	2	60,000	(18)	(136)	300
ITG-36	36" (914 mm)	3	90,000	(26)	(195)	430
ITG-48	48" (1219 mm)	4	120,000	(35)	(261)	575
ITG-60	60" (1524 mm)	5	150,000	(44)	(328)	725
ITG-72	72" (1829 mm)	6	180,000	(53)	(396)	875

Measurements in () are metric equivalents.

MODEL	GRIDDLE PLATE DIMENSIONS		CRATED DIMENSIONS	
	DIMENSIONS	DIMENSIONS	DIMENSIONS	DIMENSIONS
ITG-24	24" w x 24" d (610 x 610 mm)	24" w x 32-3/8" d x 14" h (610 x 822 x 356 mm)	26-1/2" w x 36" d x 16-1/2" h (673 x 914 x 419 mm)	
ITG-36	36" w x 24" d (914 x 610 mm)	36" w x 32-3/8" d x 14" h (914 x 822 x 356 mm)	38-1/2" w x 36" d x 16-1/2" h (978 x 914 x 419 mm)	
ITG-48	48" w x 24" d (1219 x 610 mm)	48" w x 32-3/8" d x 14" h (1219 x 822 x 356 mm)	50-1/2" w x 36" d x 16-1/2" h (1283 x 914 x 419 mm)	
ITG-60	60" w x 24" d (1524 x 610 mm)	60" w x 32-3/8" d x 14" h (1524 x 822 x 356 mm)	62-1/2" w x 36" d x 16-1/2" h (1588 x 914 x 419 mm)	
ITG-72	72" w x 24" d (1829 x 610 mm)	72" w x 32-3/8" d x 14" h (1829 x 822 x 356 mm)	74-1/2" w x 36" d x 16-1/2" h (1892 x 914 x 419 mm)	

MANIFOLD PRESSURE		MANIFOLD SIZE
NATURAL GAS	PROPANE GAS	
5.0" W.C.	10.0" W.C.	3/4" (19 mm)

Specify elevation, if over 2,000 ft.

CLEARANCE REQUIREMENTS
For use only on non-combustible surfaces. Provide 0" clearance from non-combustible surfaces and 6" (152 mm) from combustible surfaces.

- OPTIONS AND ACCESSORIES**
- Stainless steel equipment stands
 - 6" (152 mm) casters for equipment stands
 - Open burners available, set of 2 burners, add 12" (305 mm) to width and "OB-2" to model number
 - Open burners available, set of 4 burners, add 24" (610 mm) to width and "OB-4" to model number
 - 7" (178 mm) deep, stainless steel front landing ledge
 - 9" (229 mm) deep, stainless steel front landing ledge
 - Chrome griddle top, (add "-CG" to model number)
 - Extra grease can



1128 Sherborn Street Corona, CA 92879
800.343.7790 Ph: 951.281.1830 Fx: 951.281.1879
www.imperialrange.com
E-mail: imperialsales@imperialrange.com

Model Numbers

ITG-24-OB-2

ITG-36-OB-2

ITG-48-OB-2

ITG-60-OB-2

ITG-72-OB-2

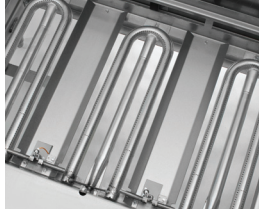

Aeration baffles between burners spread heat across the griddle plate for even heating.



Thick highly polished steel griddle plate maintains selected temperatures.

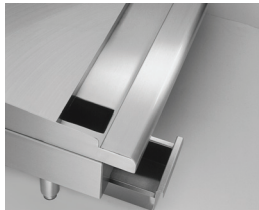

Stainless steel grease gutter and 1 gal. (3.8 L) grease can.



Two rings of flame for even cooking no matter the pan size.

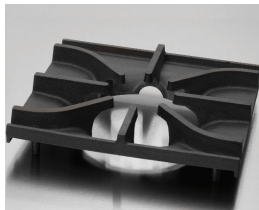

Front grate with anti-clogging pilot shield protects the pilot from grease and debris.



ITG-36-OB-2 shown

GRIDDLE BURNERS - Thermostat maintains selected temperature during peak hours.

- Each griddle burner is rated at 30,000 BTU (9 KW).
- Aeration baffles between burners spread the heat evenly across the entire griddle surface.
- Burners are located every 12" (305 mm).
- Each burner has an adjustable gas valve and continuous pilot for instant ignition.

GRIDDLE PLATE - Highly polished 1" (25 mm) thick steel plate holds temperature and has a quick recovery.

- Full 24" (610 mm) plate depth for more cooking surface.
- Surface is ideal for a large range of menu items.
- Optional chrome griddle top is available as an option.

GREASE MAINTENANCE - Stainless steel grease gutter is 4" (102 mm) wide.

- Large 1 gal (3.8 L) capacity grease can has a weep hole to indicate when full.
- Grease can removes easily.

OPEN BURNERS - PyroCentric™ 32,000 BTU (9 KW) anti-clogging burner with a 7,000 BTU/hr. (2 KW) low simmer feature. Two rings of flame for even heating.

- Cast iron PyroCentric burners are standard.
- Burners are anti-clogging and lift-off for easy cleaning. No gaskets or screws.
- One standing pilot per burner for instant ignition.

GRATES - Front grates measure 12" x 11" (305 x 279 mm). Back grates are 12" x 13" (305 x 330 mm).

- Back grates are sized for positioning large stock pots directly over burner and feature a hot air dam.
- Pots slide easily from section to section and onto landing ledge.
- Grates are cast iron for a long service life.

EXTERIOR - Stainless steel front, sides, splash guard and ledge.

- Stainless steel ledge is one piece rolled for cleaning convenience.
- Range match profile when placed on a refrigerated base or equipment stand.
- Control knobs are constructed of virtually unbreakable plastic for protection grip.
- 4" (102 mm) stainless steel legs are included.
- One year parts and labor warranty.



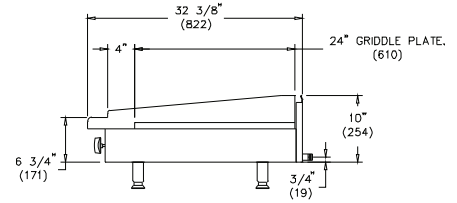
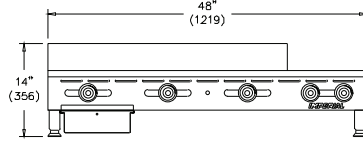
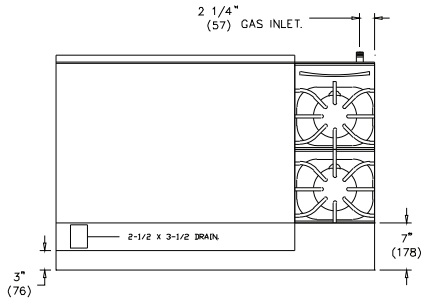

THERMOSTATIC CONTROLLED GRIDDLES and OPEN BURNER COMBO

MODEL	WIDTH	GRIDDLE BURNERS	GAS OUTPUT		SHIP WEIGHT	
			BTU	(KW)	(KG)	LBS
ITG-24-OB-2	36" (914 mm)	2	124,000	(36)	(159)	350
ITG-36-OB-2	48" (1219 mm)	3	154,000	(45)	(222)	490
ITG-48-OB-2	60" (1524 mm)	4	184,000	(54)	(288)	635
ITG-60-OB-2	72" (1829 mm)	5	214,000	(63)	(355)	785
ITG-72-OB-2	84" (2133 mm)	6	244,000	(72)	(423)	935

Measurements in () are metric equivalents.

MANIFOLD PRESSURE		MANIFOLD SIZE
NATURAL GAS	PROPANE GAS	
5.0" W.C.	10.0" W.C.	3/4" (19 mm)

Specify elevation, if over 2,000 ft.

CLEARANCE REQUIREMENTS

For use only on non-combustible surfaces. Provide 0" clearance from non-combustible surfaces and 6" (152 mm) from combustible surfaces.

MODEL	GRIDDLE PLATE DIMENSIONS	DIMENSIONS	CRATED DIMENSIONS
ITG-24-OB-2	24" w x 24" d (610 x 610 mm)	36" w x 32-3/8" d x 14" h (914 x 822 x 356 mm)	38-1/2" w x 36" d x 16-1/2" h (978 x 914 x 419 mm)
ITG-36-OB-2	36" w x 24" d (914 x 610 mm)	48" w x 32-3/8" d x 14" h (1219 x 822 x 356 mm)	50-1/2" w x 36" d x 16-1/2" h (1283 x 914 x 419 mm)
ITG-48-OB-2	48" w x 24" d (1219 x 610 mm)	60" w x 32-3/8" d x 14" h (1524 x 822 x 356 mm)	62-1/2" w x 36" d x 16-1/2" h (1588 x 914 x 419 mm)
ITG-60-OB-2	60" w x 24" d (1524 x 610 mm)	72" w x 32-3/8" d x 14" h (1829 x 822 x 356 mm)	74-1/2" w x 36" d x 16-1/2" h (1892 x 914 x 419 mm)
ITG-72-OB-2	72" w x 24" d (1829 x 610 mm)	84" w x 32-3/8" d x 14" h (2133 x 822 x 356 mm)	86-1/2" w x 36" d x 16-1/2" h (2197 x 914 x 419 mm)

OPTIONS AND ACCESSORIES

- Stainless steel equipment stands
- 6" (152 mm) casters for equipment stands
- Set of 4 burners, add 12" (305 mm) to width and "OB-4" to model number
- 7" (178 mm) deep, stainless steel front landing ledge
- 9" (229 mm) deep, stainless steel front landing ledge
- Chrome griddle top, (add "-CG" to model number)
- Extra grease can

