



# BEVERAGE-AIR

Project: \_\_\_\_\_

AIA#

Item: \_\_\_\_\_

Location: \_\_\_\_\_

SIS#

Approved: \_\_\_\_\_

## BOTTOM MOUNT REACH-IN FREEZER

FB49HC Glass Door Reach-in Freezer  
Hydrocarbon Series

MODEL:

FB49HC-1G



FB49HC-1G

**3 Year Parts/Labor Warranty**  
**Additional 2 Year Compressor Warranty**

### CABINET CONSTRUCTION

- Stainless steel front and doors, gray painted sides
- Gray painted aluminum interior
- Full electronic control
- LED lighting standard
- Anti-microbial door handles
- Self-closing doors with 120° Stay-open feature, on spring-loaded hinges
- One -piece grille allow easy removal/installation for preventative maintenance
- Six (6) heavy duty epoxy coated wire shelves per section
- 6" casters standard with (2) brakes
- Maintains product temperatures of 0° F

### OPTIONS & ACCESSORIES

- Stainless steel universal tray slide pair, 1 tray slide set for (1) 18" x 26" or (2) 14" x 18" pans (AC)
- Epoxy shelves
- Shelf clips
- 3" caster or 6" legs
- Door locks
- Remote option

### REFRIGERATION SYSTEM

- Refrigeration system uses R290 refrigerant to comply with all environmental concerns
- Automatic, electric defrost
- Epoxy coated evaporator coil

FB49HC Bottom Mount Models: Vista Series



3779 Champion Blvd., Winston-Salem, NC 27105  
1-888-845-9800 Fax: 1-336-245-6453  
Beverage-Air.com sales@bevair.com



# BEVERAGE-AIR

MODEL	FB49HC-1G
<b>EXTERNAL DIMENSIONAL DATA</b>	
Width Overall	52"
Depth Overall with Handle	33 3/4"
Height Overall with 6" Casters	84 1/4"
Number of Doors	2
Depth with Door Open 90°	56 1/8"
Door Opening	22 3/4" x 52 5/8" (2)
<b>INTERNAL DIMENSIONAL DATA</b>	
NET Capacity (cubic ft.)	46.2
Internal Width Overall (in)	49"
Internal Depth Overall (in)	25 7/8"
Internal Height Overall (in)	61 5/8"
Internal Height Useable (in)	53"
Number of Shelves	6
<b>ELECTRICAL DATA</b>	
Full Load Amperes 115/60/1	11
<b>REFRIGERATION DATA</b>	
Horsepower	3/4
Capacity (BTU/Hr)*	2312
<b>WEIGHT DATA</b>	
Gross Weight (Crated lbs)	564 lbs
Height - Crated	85"
Width - Crated	54"
Depth - Crated	36"

## Vista Series Bottom Mount Reach-in Freezer Model: FB49HC-1G

### Model Views

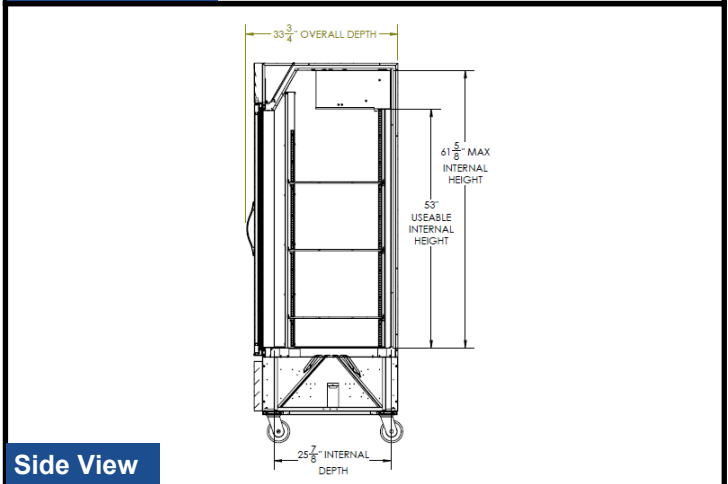
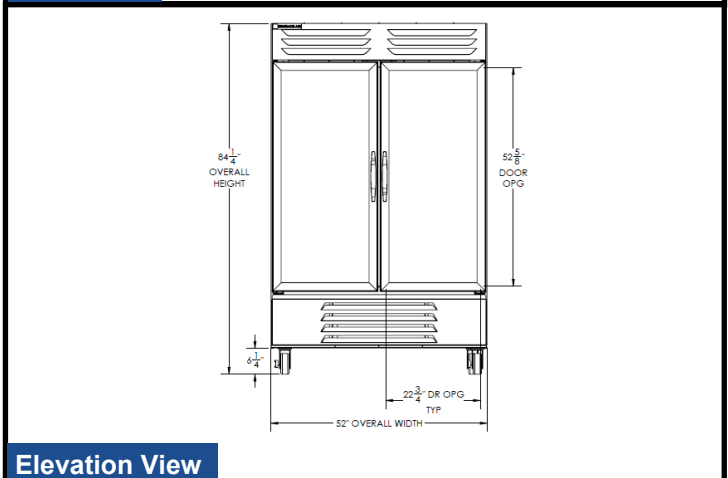
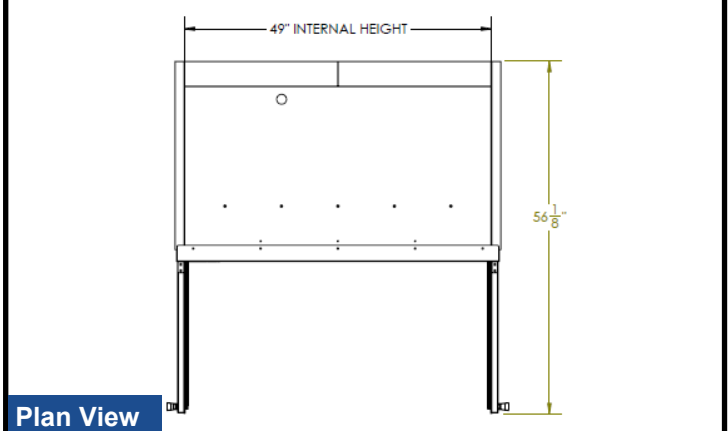

### ELECTRICAL CONNECTION



115/60/1  
NEMA-5-15P

Units pre-wired at factory and include 8' long cord and plug set.



an Ali Group Company



The Spirit of Excellence

3779 Champion Blvd., Winston-Salem, NC 27105  
1-888-845-9800 Fax: 1-336-245-6453  
Beverage-Air.com sales@bevair.com