



# BEVERAGE-AIR

Project: _____	AIA#
Item: _____	
Location: _____	SIS#
Approved: _____	

**MODELS:**  
**DPD67HC-4**

## DPD FOOD PREPARATION SERIES

DPD67HC Deli/Pizza Prep Table with Four Drawers  
Hydrocarbon Series



**DPD67HC-4**

**3 Year Parts/Labor Warranty**  
**Additional 2 Year Compressor Warranty**

### CABINET CONSTRUCTION

- Stainless steel front, sides, top, drawers and grille (*galvanized back & bottom*)
- Interior liner is made of corrosion resistant aluminum
- Aluminum top interior liner prevents spill from falling into cabinet
- Stainless steel top
- Removable hoods and insulated lid assemblies are made of matching stainless steel
- Magnetic gaskets provide positive seal on drawers
- 3" Casters, 2 with brakes standard
- 19" Wide reversible cutting board is removable for easy cleaning
- Units will accept pans up to 6" deep (pans are not included)
- Drawer frames are heavy duty stainless steel
- Telescoping slides, with locking mechanism to prevent drawers from being pulled off of cabinet
- Heavy duty pan locking divider supports are standard in drawers
- Maintains product temperatures between 36° - 38°F

### OPTIONS & ACCESSORIES

- Stainless steel back and grille
- Stainless steel interior
- Combination models available
- Clear lid models
- Door locks
- Bun tray rack
- Composite cutting board
- 6" Casters
- 6" Legs
- Remote option

### REFRIGERATION SYSTEM

- Refrigeration system uses R290 refrigerant to comply with all environmental concerns
- Automatic, non-electric defrost
- Epoxy coated evaporator coil

DPD67HC Food Preparation Series: Deli/Pizza Prep Model



3779 Champion Blvd., Winston-Salem, NC 27105  
1-888-845-9800 Fax: 1-336-245-6453  
Beverage-Air.com sales@bevair.com



# BEVERAGE-AIR

MODEL	DPD67HC-4
<b>EXTERNAL DIMENSIONAL DATA</b>	
Width Overall	67"
Depth Overall with Cutting Board	37"
Height Overall with 3" Casters	53"
Number of Drawers	4
Depth with Drawers Extended	56 1/8"
Drawers Opening (in)	(4) 21 5/8" x 10"
Depth, Cutting Board	19"
<b>INTERNAL DIMENSIONAL DATA</b>	
NET Capacity (cubic ft.)	20.68
Internal Width Useable (in)	48"
Internal Depth Overall (in)	26"
Internal Height Overall (in)	23 3/4"
<b>ELECTRICAL DATA</b>	
Full Load Amperes 115/60/1	4.5
<b>REFRIGERATION DATA</b>	
Horsepower	1/3
Capacity (BTU/Hr)*	3088
<b>WEIGHT DATA</b>	
Gross Weight (Crated lbs)	484 lbs
Height - Crated	47 1/2"
Width - Crated	70"
Depth - Crated	37"

## Deli/Pizza Preparation Table

Models: DPD67HC-4

### Model Views

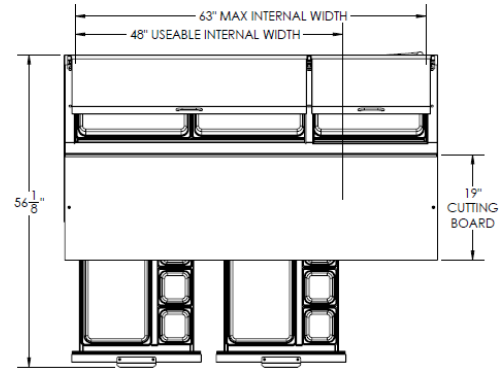

### Plan View

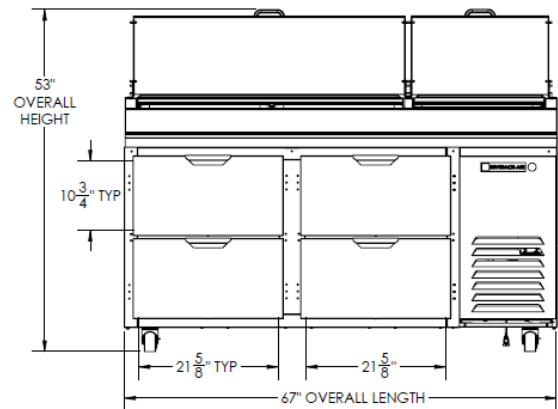

### Elevation View

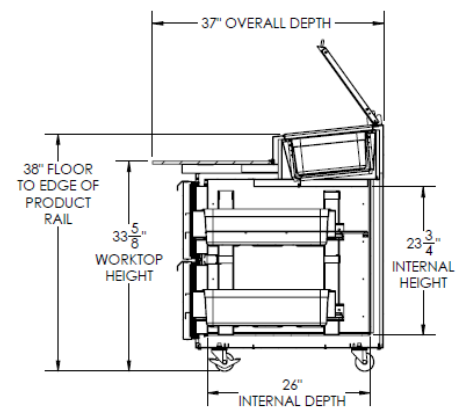

### Side View

### ELECTRICAL CONNECTION



115/60/1  
NEMA-5-15P

Units pre-wired at factory and include 8' long cord and plug set.



an Ali Group Company



The Spirit of Excellence

3779 Champion Blvd., Winston-Salem, NC 27105  
1-888-845-9800 Fax: 1-336-245-6453  
Beverage-Air.com sales@bevair.com