



AX-CL06M

Full Size Combi Oven
Manual Controls - Reversing Fans - 6 Shelves



	Time, temperature, steam	Features
Manual controls	Time, temperature, steam	
Load capacity	6 shelves for full size sheet pans	• Advanced airflow design
High speed reversing fans	2 (3,200 rpm)	• Automatic high speed reversing fans
Space between shelves	3.14" (80 mm)	• Manual control: 120 minute timer or continuous ON
Power requirements	10.5Kw/208V/60/3 32A 14.0Kw/240V/60/3 36A Oven supplied with power cord only / no plug	• Interior halogen light
Temperature	86° - 545° F	• Includes electro valve for direct water connection
Equipped with	120 minute timer Signal at end of cycle	• Adjustable steam percentage (0-100%)
Cavity size (inches)	28.35 x 22.20 x 24.10 (WxDxH)	• Micro safety switch shuts oven off when door is open
Unit dimensions (inches)	38.60 x 33.64 x 36.35 (WxDxH)	• Heavy duty stainless steel body construction
Shipping dimensions (inches)	41.35 x 40.55 x 39.37 (WxDxH)	• "Cold Door" design with double pane glass
Net / Ship weight	220 lb / 263 lb	• Reinforced door hinges
		• Oven cavity is insulated with ultra-high temperature fiberglass insulation
		• 3 Stainless steel wire shelves
		• Hand spray for cleaning is included
		• Ovens can be stacked (kit required)
		• Warranty: 2 year parts & 1 year labor exclusive of lights, gaskets and glass (60 days)

COMBI ACCESSORIES



AX-C10ST OVEN STAND

- Heavy duty oven stand with tray support
- Slides accommodate full size pans
- Dimensions: 33.47" x 24.40" x 31.50"
- Heavy duty stainless steel (assembly required)
- Ship weight: 54 lbs
- Shipping dimensions: 38.60" x 28.35" x 8.66"



**125-R15
R15 CASTERS**

Set of 4
(2 with brakes)
For stand only



**124-KITC
STACKING KIT**



**125-0323
STACKING KIT
CASTERS**

Set of 4
(2 with brakes)



**125-0325
STACKING
CASTER SET**

(4 casters- 2 braked)
(2 support brackets)



**139-0002
DEGREASER**



**139-0001
COMBI CLEANER**



**124-WDFA
WATER FILTER**

COMBI OVEN TRAYS

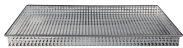

**124-GP31
FRY GRID**



**124-GP32
GRIDDLE GRID**



**124-GP28
GRANITE
MULTI-BAKING
TRAY**



**124-GP36
MULTIFUNCTIONAL
NON STICK
ALUMINUM TRAY**



**124-PT12
60X40
ALUMINUM
PERFORATED TRAY**



**124-PT13
60X40
ALUMINUM
TRAY**



**124-PG15
SHELF RACK**

LINE DRAWINGS

AX-CL06M

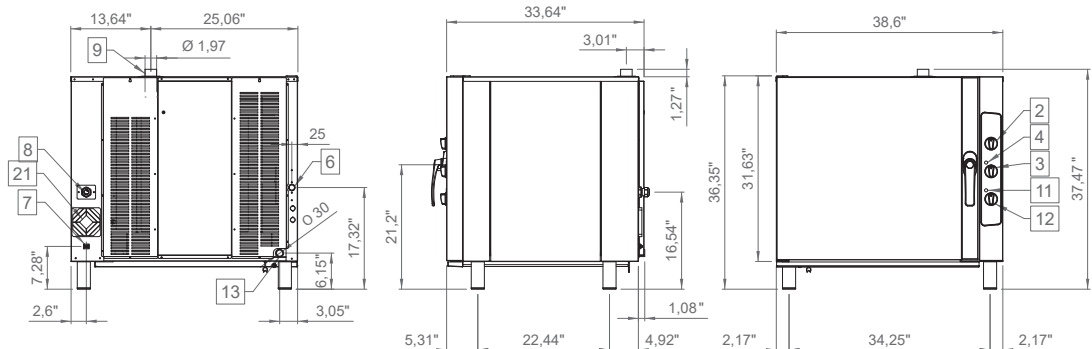

3560 NW 56th Street
Fort Lauderdale, FL, United States 33309
Telephone: 786.600.4687 / Toll Free: 844.218.8477
Fax: 786.661.4100

5659 Royalmount Ave.
Montreal, QC, Canada H4P 2P9
Telephone: 514.737.9701 / Toll Free: 888.275.4538
Fax: 514.342.3854 / Toll Free: 877.453.8832
sales@mvpgroupcorp.com / mvpgroupcorp.com