

Model Numbers
IFS-50-E IFS-50-EU



Immersed element models are the lowest cost alternative for electric fryers.



Tilt-up elements provide full access to the frypot for cleaning.



Stainless steel exterior (except back) is easy to clean and has a professional look.



IFS-50-E shown

ELECTRIC ELEMENTS - Elements are located inside the stainless steel frypot, below the fry zone.

- Element output is 15.25 KW.
- Two element styles are available, immersed elements are the most economical, the tilt-up elements offer complete access to the frypot for cleaning.
- Direct heat-to-element contact heats oil quickly resulting in less absorption and better tasting food.
- Snap acting electronic thermostat has a 200°F - 400°F. (93°C - 204°C) temperature range that extends oil life and produces a uniformly cooked product.

LARGE COOL ZONE - Captures and holds particles out of the fry zone.

- Reduces taste transfer.

STAINLESS STEEL FRYPOTS - Large 14" x 14" (356 x 356 mm) frying area.

- Frypot sides are robotically welded stainless steel to virtually eliminate leaks.
- Fine mesh wire crumb screen is included.
- Deep drawn bottom facilitates draining, slants toward the drain.
- 1-1/4" (32 mm) full port drain valve empties frypot quickly and safely.
- Two large, nickel-plated fry baskets with vinyl coated heat protection handles are included.
- 304 stainless steel frypot.

EXTERIOR FEATURES - Stainless steel front, door, sides and basket hanger.

- Welded and polished stainless steel seams.
- Full heat shield protects control panel.
- Full bottom chassis provide structural support.
- Plate mounted 6" (152 mm) heavy duty stainless steel legs or optional casters assure secure support.
- One year parts and labor warranty. Limited warranty on frypot, stainless steel frypot is five years pro-rated.



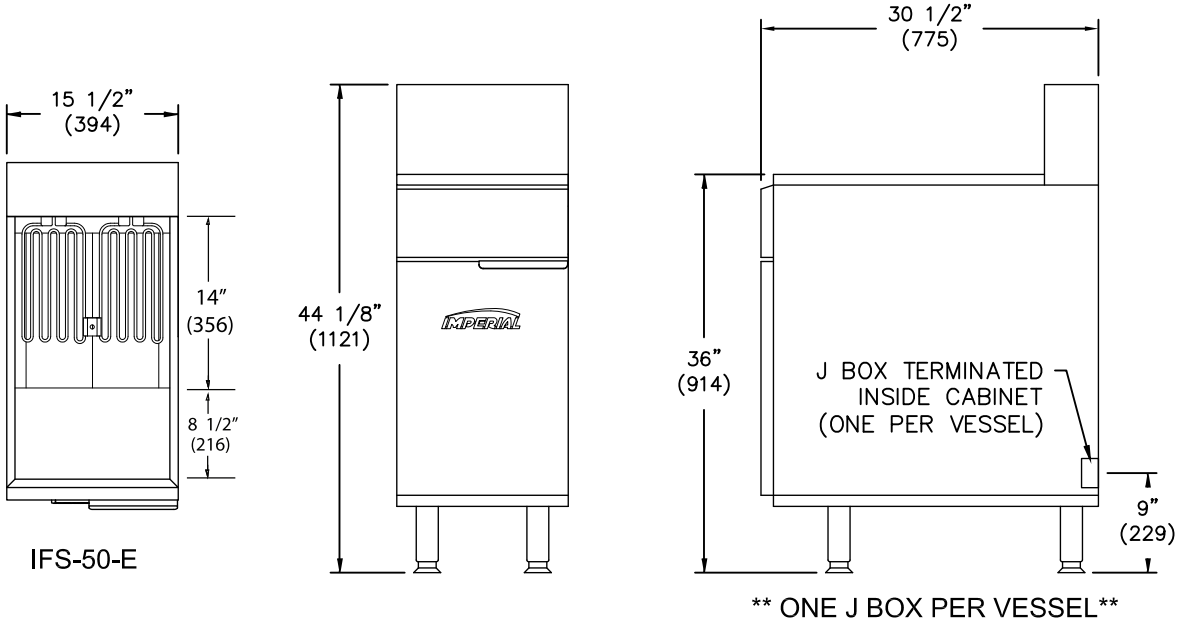

50 LB. ELECTRIC FRYERS

MODEL	DESCRIPTION	OIL CAPACITY	TOTAL OUTPUT	SHIP WEIGHT (KG)	LBS
IFS-50-E	Immersed	50 lbs (22 L)	15.25 KW	(114)	253
IFS-50-EU	Tilt-up	50 lbs (22 L)	15.25 KW	(114)	253
IFS-DS	Top draining section with storage cabinet, no filter	N/A	N/A	(60)	130

Measurements in () are metric equivalents.

NOTES

- "DS" drain station with storage cabinet, no filter. Includes a 4" (102 mm) deep stainless steel drain pan

MODEL	FRYING AREA	DIMENSIONS	CRATED DIMENSIONS
IFS-50-E	14" x 14" (356 x 356 mm)	15-1/2" w x 30-1/2" d x 44-1/8" h (394 x 775 x 1121 mm)	18" w x 34" d x 35" h (457 x 864 x 889 mm)
IFS-50-EU	14" x 14" (356 x 356 mm)	15-1/2" w x 30-1/2" d x 44-1/8" h (394 x 775 x 1121 mm)	18" w x 34" d x 35" h (457 x 864 x 889 mm)
IFS-DS	N/A	15-1/2" w x 30-1/2" d x 44-1/8" h (394 x 775 x 1121 mm)	18" w x 34" d x 35" h (457 x 864 x 889 mm)

ELECTRIC AMPERAGE REQUIREMENTS

MODEL	TOTAL KW	VOLTAGE	PHASE	AMPS
IFS-50-E	15.25 KW	208	3	43
	15.25 KW	240	3	37
	15.25 KW	480*	3	19
IFS-50-EU	15.25 KW	208	3	43
	15.25 KW	240	3	37
	15.25 KW	480*	3	19

* For export only, additional charge

CLEARANCE REQUIREMENTS

For use only on non-combustible floors. Legs or casters are required for non-combustible floors; or 2" (51 mm) overhang is required when curb mounted. Provide 0" clearance from non-combustible surfaces and 6" (152 mm) from combustible surfaces.

OPTIONS AND ACCESSORIES

- Fryer drain station with storage cabinet
- Heat lamp for drain station
- Stainless steel joiner strips
- 20-1/2" (521 mm) high backguard, no shelf
- Automatic basket lifts (for IFS-50-E only)
- Computer controls
- Manual timer
- Catering package for easy transporting
- Extra fry baskets with vinyl coated handles
- 6" (152 mm) casters

