

# Real-time Release of Pharmaceutical Waters with On-line Microbial Monitoring

Measuring bioburden contamination in Purified Water (PW), Ultrapure Water (UPW) and Water for Injection (WFI) has almost exclusively depended on time-consuming and error-prone culture-based lab measurements. Recent developments in spectroscopic technology now offer accurate, continuous, on-line quantification of microbial contamination in pharmaceutical water systems.

## Introduction

Increasing competition, expiring patents and changes in regulations are placing ever-growing pressures on pharmaceutical companies. These stresses are resulting in an increasing focus, from regulators to drug manufacturers, on how modern production methodologies can be applied in the pharmaceutical industry that will enable greater efficiencies alongside increased product safety.

The FDA's Process Analytical Technology (PAT) initiative, EMA Guidance on Real Time Release, ICH Guidelines Q8–10, etc. all offer opportunities to increase production efficiency for even the most conservative drug companies. It is not surprising then, that there has been growing adoption of continuous analytical technologies that can rapidly identify out-of-specification conditions and eliminate the time delay associated with laboratory testing.

## The requirement for real-time microbial detection

Maintaining the quality of Purified Water and Water for Injection is vital in the pharmaceutical industry. Here, on-line analytics plays a major role in real-time monitoring of



water conductivity and total organic carbon (TOC). However, due to a lack of such instrumentation for the measurement of microbial contamination, this vital measurement has been dominated by laboratory culture-based methods. This situation causes great frustration as on-line conductivity and TOC sensors allow real-time release of pharmaceutical waters, yet any bioburden contamination requires days to be detected.

Further, manual sampling of a pharmaceutical water distribution loop or multiple points-of-use (POU) to conduct traditional bacterial culture tests can result in a high percentage of false-positive results. The investigation of false-positive events is time-consuming and expensive, with some industry estimates putting the cost per event from USD 5,000 to 18,000.

Due to the high number of POUs in a production facility and the time involved in plate counting, a single point may only be tested a few times in a month. This can make identification and remediation of local microbial issues very challenging. This is compounded by the fact that when a sample is collected for testing, it represents only a small volume of the water system or point-of-use at that specific time.

The pharmaceutical industry welcomes the advances in technology that have led to the development of microbial

analyzers that offer real-time results and decrease the delays and risks associated with the plate count method.

#### Cutting-edge fluorescence technology

Laser-induced fluorescence is an optical measurement technique in which a molecule is excited to a higher energy level by the absorption of photons from an excitation source. The molecule then releases the photons resulting in the emission of light at a longer wavelength than the excitation source, producing fluorescence.

All microorganisms contain metabolites, NADH and riboflavin, to regulate growth and development. These metabolites can fluoresce when exposed to an excitation source of certain wavelengths. The 7000RMS utilizes this phenomenon as part of its measurement technique to detect microbial presence.

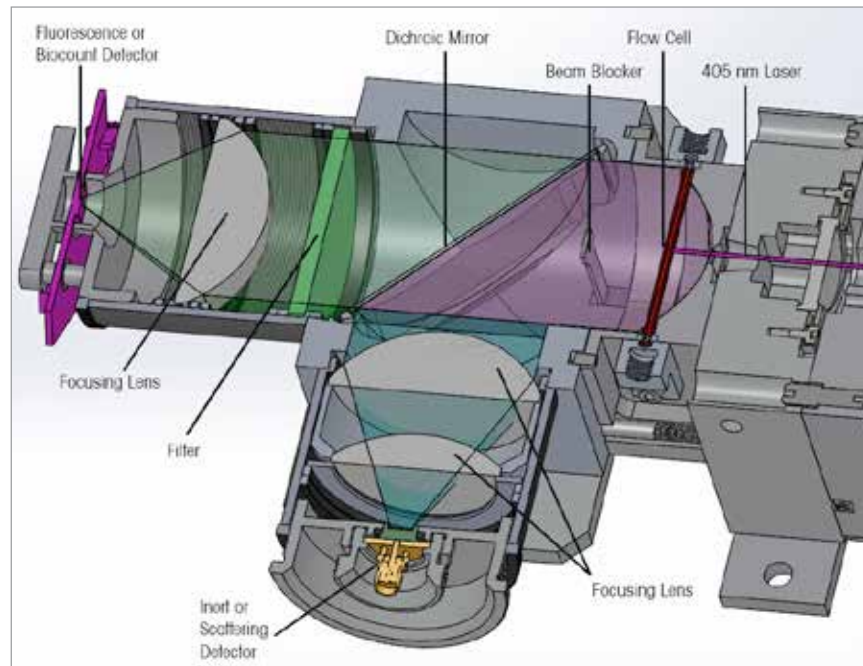

Analysis of fluorescence and scattered light distinguishes microorganisms from inert material.



#### **Real-time microbial detection analyzer**

METTLER TOLEDO Thornton's 7000RMS™ is an at-line analyzer for real-time, continuous measurement of bio-burden in pharmaceutical waters. It uses laser induced fluorescence to instantly measure microbial contamination without any requirement for consumables or incubation periods.

A sample stream from the water supply is connected to the instrument's overflow chamber. From here water is pumped into the analyzer at a controlled flow rate of 30 mL/min. As water flows through the flow cell it is illuminated by a 405 nm laser, causing fluorescence of the metabolites NADH and riboflavin. This fluorescence signal is then detected (captured) by a photodiode. At the same time Mie scattering occurs when any microorganism or particle is illuminated by the laser. The Mie scattering signal is then detected (captured) by a separate photodiode. The data from both detectors is processed using advanced algorithms to determine if an Auto Fluorescent Unit (AFU) or cell is present. When both signals meet a specific set of criteria at the same time, an AFU is reported.

The analyzer's touchscreen interface displays the AFU results in cells/volume. The 7000RMS offers user-defined volume report intervals as well as alert, action and breach

limits. It also offers SCADA connectivity with Modbus TCP, analog outputs and Wi-Fi capability.

#### **Lower risk, greater process control**

"USP < 1231 > Water for Pharmaceutical Purposes" recommends that pharmaceutical water systems should be monitored at a frequency that ensures the system is in control and continues to produce water of acceptable quality. The general information chapter endorses operating monitoring instruments continuously in order that historical in-process data can be recorded for examination. Over time, trend analysis can be used as a basis for conducting loop maintenance.

Real-time and historical data from the 7000RMS enables rapid identification of deteriorating or improving microbiological control. Use of 7000RMS analyzers at various POU's or distribution sampling points will help pinpoint the source of any problems and provide rapid assurance of successful remediation.

The 7000RMS enables risk reduction and greater process control, while offering significant costs savings from the combined decrease in laboratory testing and false-positive results. A facility operating eight water systems and ten 7000RMS analyzers can more than recoup the investment cost in less than a year.

### Conclusions

Initiatives such as PAT and QBD, and the pharmaceutical industry's recognition of a need for increased, real-time monitoring of pure pharmaceutical waters has led to instrumentation that allows companies to rely less on time-consuming, culture-based lab measurements of bacteria.

Rapid microbiological methods hold the potential to accelerate and even improve microbe quality control of Pharmaceutical Water Systems. The improved testing and speed of response will allow pharmaceutical products to reach the market faster and improve the understanding of the water process. Rapid microbiology detection will permit timely and effective investigations of any microbial event and enable corrective actions to be taken swiftly.

The advanced Laser Induced Fluorescence technology employed in METTLER TOLEDO Thornton's 7000RMS microbial detection analyzer provides continuous and accurate detection of bioburden in pharmaceutical grade water. Assurance of in-specification microbial levels and real-time detection of contamination leads to improved product quality, greater process understanding, risk reduction and lower operating costs.

1. "Advancing Regulatory Science at FDA – A Strategic Plan: August 2011" [www.fda.gov/regulatoryscience](http://www.fda.gov/regulatoryscience)

2. "Novel Concept for Online Water Bioburden Analysis: Key Considerations, Applications, and Business Benefits for Microbiological Risk Reduction" *American Pharmaceutical Review*, May/June 2013.

► [www.mt.com/7000RMS](http://www.mt.com/7000RMS)



[www.mt.com/pro](http://www.mt.com/pro)

Visit for more information

#### METTLER TOLEDO Group

Process Analytics Division

Local contact: [www.mt.com/pro-MOs](http://www.mt.com/pro-MOs)

Subject to technical changes

©12/2017 METTLER TOLEDO. All rights reserved.

7000RMS is a trademark of the METTLER TOLEDO Group.

58 087 116 Rev A 12/17