

Product Information ILM-4**FOOD**

Inductive Conductivity Meter ILM-4

Application/Specified Usage

- Inductive measurement of the specific conductivity of liquid media in the range of 0...1000 mS/cm.
- Designed for hygienic applications in food-, beverage- and pharmaceutical industries.

Application Examples

- Controlling of CIP processes (e. g. phase separation detergents/water)
- Concentration measurement (e. g. Alkali and acid concentration in remaking)
- Monitoring of product quality, quality control

Hygienic Design/Process Connection

- Hygienic process connection with CLEANadapt
- Versions available with EHEDG approval
- Versions available to conform to 3-A Standard 74-
- All wetted materials are FDA-conform
- Sensor completely made of stainless steel, sensor tip of PEEK material
- Complete overview of process connections: see order code
- The Anderson-Negele CLEANadapt system offers a flow-optimized, hygienic and easily sterilizable installation solution for sensors.

Features/Advantages

- CIP/SIP cleaning up to 150 °C (302 °F)/maximum 60 minutes
- Wear-free, inductive measurement
- In contrast to conductive measurement procedures, no problems with electrode deterioration or polarization.
- Accurate measurement through compensation of temperature influences.
- High reproducibility of $\leq 0.2\%$ of measurement value.
- Analog outputs for conductivity and temperature are a standard feature.
- Analog outputs for conductivity, temperature or concentration are freely adjustable.
- Hybrid technology with digital and analog interface
- Short reponse time of 1.2 s for highest efficiency
- Installation in tube diameters from DN 40

Options/Accessories

- Version with longer toroid housing for pipes \geq DN 65 or for installation into T-fitting
- Preassembled cable for M12 plug-in connector
- Display module Simple User Interface (SUI) and Large User Interface (LUI)
- Remote version with cable length up to 30 m

Communication

IO-Link

4...20 mA
ILM-4 / L20 Compact Version**ILM-4R / L20 Remote Version****Large User Interface (LUI)**

| Specification | | |
|--------------------------------|---|--|
| Process connection | CLEANadapt Tri-Clamp Varivent | G1" 1½", 2", 2½", 3" DN 25 (type F), DN 40/50 (type N) |
| Materials | Connecting head Threaded connector Immersible body Plastic cap/sight glass | Stainless steel 1.4308 (AISI CF-8) Stainless steel 1.4305 (AISI 303) PEEK, FDA number 21 CFR 177.2415 Polycarbonate |
| Temperature ranges | Ambient Process CIP/SIP cleaning | -10...+70 °C (14...158 °F) -10...+130 °C (14...266 °F) Up to 150 °C (302 °F) max. 60 min |
| Operating pressure | | Max. 16 bar |
| Protection class | | IP 69 K |
| Reproducibility | of conductivity | ≤ ±0,2 % of measured value |
| Resolution/measurement range | ≤ 1 mS/cm ≤ 10 mS/cm ≤ 100 mS/cm ≤ 1000 mS/cm | 0.001 mS/cm 0.01 mS/cm 0.1 mS/cm 1 mS/cm |
| Accuracy | Slope Offset | ±1 % of measurement range (plus additional inaccuracy of calibration fluid) ±20 µS/cm |
| Long-term stability | | ±0.5 % of upper range limit |
| Accuracy of temperature output | ≤ 100 °C (212 °F) 100...150 °C (212...302 °F) | Max. 0.5 °C (0.9 °F) Max. 1.0 °C (1.8 °F) |
| Response time | Conductivity Temperature (t ₉₀) | < 1.2 s < 20 s |
| Electrical connection | Cable gland Cable connection Power supply | 2x M16 x 1.5 2x M12 connector 1.4301 (AISI 304) 18...36 V DC max. 190 mA |
| Remote cable (ILM-4R only) | PVC-cable | 8 pin, twisted pair, unshielded, with M12 coupling/straight plug |
| Communication | Analog Digital | 2x Analog output 4...20 mA, short circuit proof 1x Digital input (24 V DC) IO-Link |
| LCD display | Backlit display | 5 lines |
| Measuring principle | Wear-free | Inductive |

Measuring Principle of the Inductive Conductivity Meter

An alternating current generates a magnetic field in the primary coil (sender) which induces a current in the circumfluent medium. The current flow in the medium generates another magnetic field in the secondary coil (receiver). The strength of the induced current in the secondary coil depends on the conductivity of the medium. The conductivity of the liquid medium is temperature dependent. To compensate the temperature error, an additional sensor (Pt1000) in the sensor tip is used for monitoring the temperature of the medium. The temperature coefficient (TC-value) of the liquid can be set up in the electronics of the ILM which is used for automatic compensation of the temperature error.

Inductive Conductivity Measurement

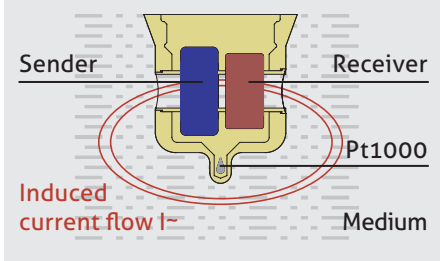

ILM-4 / G1" horizontal

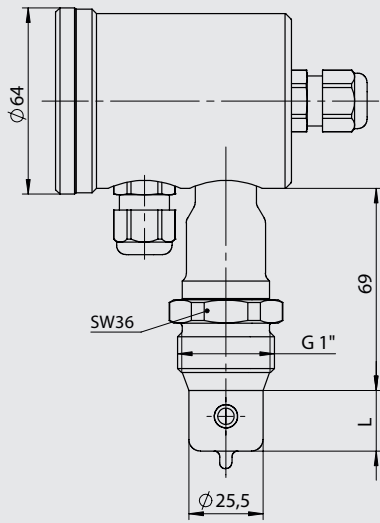

ILM-4 / G1" vertical

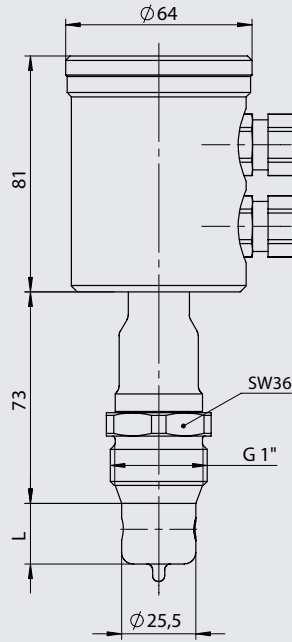

ILM-4 / Tri-Clamp vertical

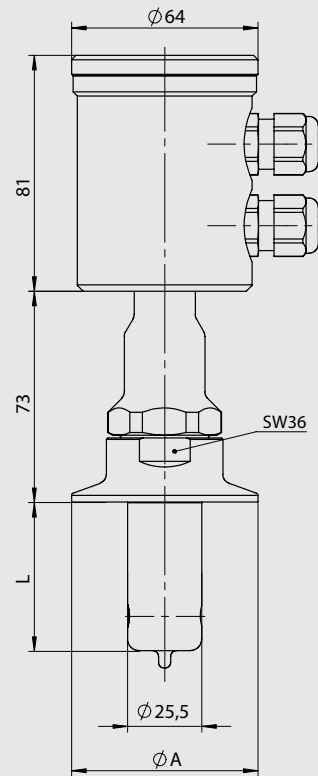

HUR / Head Unit Remote Version

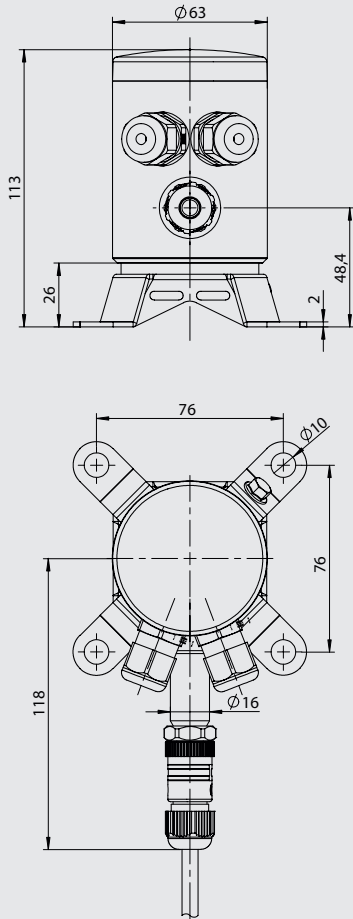

ILM-4S / G1" CLEANadapt

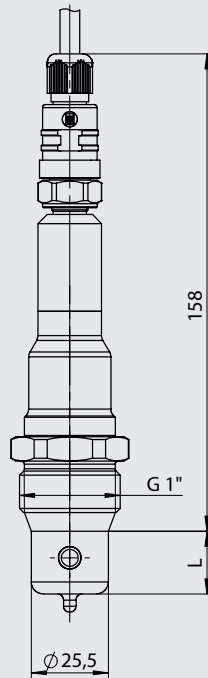

ILM-4S / Tri-Clamp

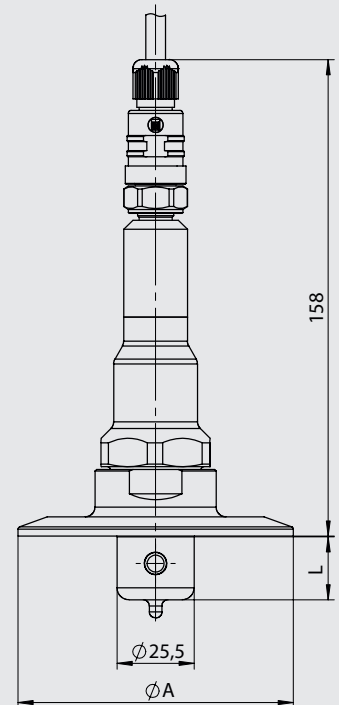

Submersion length

| Type | L [mm / inch] |
|-------------|---------------|
| ILM-4 / L20 | 20.0 / 0.79 |
| ILM-4 / L50 | 50.0 / 1.97 |

Tri-Clamp size

| Type | Ø A [mm / inch] |
|------|-----------------|
| TC1 | 50.5 / 1.99 |
| TC2 | 64.0 / 2.52 |
| T25 | 77.5 / 3.05 |
| TC3 | 91.0 / 3.54 |

Note

This product information is not an operating manual. Please note the information on device safety, installation and operation in the product operating manual.

Mechanical Connection / Installation

- The sensor has to be installed in that way that the bobbin case is entirely washed around by media and no bubbles can occur.
Installation in a rising pipe is recommended.
- The inscription "FLOW" on the bottom side of the sensor has to show in flow direction of the medium.
- Very heavy vibrations can cause measurement errors
(e. g. installation very near a pump).
- Use Negele CLEANadapt system for safe operation of measuring point!
- Attention: The maximum tightening torque for mounting is 20 Nm!
- Use a welding mandril for correct installation of CLEANadapt weld-in fittings.
Please pay attention to the weld-in and installation details in the CLEANadapt product information.

Note on 3-A Sanitary Standard 74-

Information on installation according to 3-A standard is available on our website:
www.anderson-negele.com/3A74.pdf





Click on the PDF icon to download the document.

Information

The components ILM-4S / sensor and HUR / Head Unit Remote can be purchased as spare parts separately.
The valid configuration can be seen on the product labels.

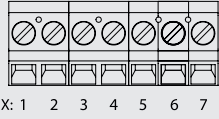
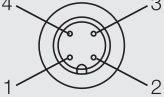
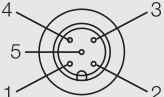
| Application / Function | Signal module | I42 | I62 | I63 |
|---|---------------|-----|-----|-----|
| IO-Link communication X3 | | ✓ | ✓ | ✓ |
| 2x analog output X45 and X67 for conductivity and temperature | | — | ✓ | ✓ |
| 1x digital input X3 for external range switching | | — | — | ✓ |

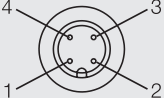
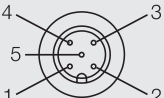
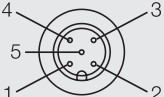
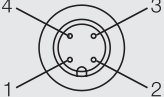
Table electrical connection

| Type | Connection | Pin assignment | | | |
|------------------------|---|--|---|---|---|
| P (1x PG) D (2x PG) |  X: 1 2 3 4 5 6 7 | Clamps 1: Power supply +24 V DC 2: Power supply - 3: Digital input X3 4: Analog output X45 + 5: Analog output X45 - 6: Analog output X67 + 7: Analog output X67 - | ✓ | ✓ | ✓ |
| A (2x M12) |  | 4 pin 1: Analog output X45 - 2: Analog output X45 + 3: Power supply +24 V DC 4: Power supply - | — | ✓ | ✓ |
| |  | 5 pin 1: Analog output X67+ 2: Not assigned 3: Not assigned 4: Analog output X67 - 5: Digital input X3 | | | |
| M (1x M12) |  | 4 pin 1: Power supply +24 V DC 2: Analog output X45 + 3: Analog output X45 - 4: Power supply - | ✓ | — | — |
| N (2x M12) |  | 4 pin 1: Analog output X45 + 2: Analog output X67 + 3: Analog output X67 - 4: Analog output X45 - | — | ✓ | ✓ |
| |  | 5 pin 1: Power supply +24 V DC 2: Not assigned 3: Not assigned 4: Power supply - 5: Digital input X3 | | | |
| C (1x M12) IO-Link |  | 5 pin 1: Power supply +24 V DC 2: Analog output X45 - 3: Power supply - 4: IO-Link 5: Analog output X45 + | ✓ | — | — |
| R (2x M12) IO-Link |  | 4 pin 1: Analog output X45 + 2: Analog output X67 + 3: Analog output X67 - 4: Analog output X45 - | — | ✓ | ✓ |
| |  | 3 pin 1: Power supply +24 V DC 3: Power supply - 4: IO-Link / Digital input X3 | | | |

Order code

ILM-4 Inductive conductivity sensor
ILM-4R Inductive conductivity sensor - remote version, remote cable must be ordered separately

Submersion length of toroid

L20 20 mm
L50 50 mm

Process connection (Ⓐ: 3-A conform, Ⓔ: EHEDG approval)

S01 CLEANadapt G1" Ⓐ Ⓔ
TC1 Tri-Clamp 1½" Ⓐ Ⓔ
TC2 Tri-Clamp 2" Ⓐ Ⓔ
T25 Tri-Clamp 2½" Ⓐ Ⓔ
TC3 Tri-Clamp 3" Ⓐ Ⓔ
V25 Varivent type F, DN 25 Ⓐ Ⓔ
V40 Varivent type N, DN 40/50 Ⓐ Ⓔ

Head orientation (not selectable for ILM-4R)

H Horizontal head orientation
V Vertical head orientation

Signal module

I42 IO-Link and 1x 4...20 mA conductivity
I62 IO-Link and 2x 4...20 mA conductivity/temperature selectable
I63 IO-Link and 2x 4...20 mA conductivity/temperature selectable, external range switching

Electrical connection

P Cable gland M16x1.5
D 2x cable gland M16x1.5
M 1x M12 connector, 4 pin output/power supply
N 2x M12 connector, 4 pin output, 5 pin input/power supply
A 2x M12 connector, 4 pin output/power supply, 5 pin output/input
C 1x M12 connector, 5 pin analog output and IO-Link
R 2x M12 connector, 4 pin analog and switching output, 3 pin IO-Link and input

Interface/Display

X Without
S Simple User Interface with small display (not for ILM-4R)
L Large User Interface with big display

Enclosure

X Plastic cap without sight glass
P Plastic cap with sight glass
M Stainless steel cap without sight glass
W Stainless steel cap with sight glass

Configuration

X Default factory settings
S Special customer settings

ILM-4 / L20 / S01 / V / I63 / D / S / P / X
 ILM-4R / L20 / S01 / I63 / D / L / P / X

Remote cable for remote version

PVC-cable, 8 pin, twisted pair unshielded, IP69K
 Length selectable in steps of 1 meter, 30 m max.

M12-PVC / 8-PBT M12 plug/coupling made of PBT plastic
M12-PVC / 8-SS M12 plug/coupling made of stainless steel

Remote cable

