

IMI PBM IGENIX® TWO-WAY BALL VALVES

SI Cast Series 9/Forged Series 8, 1/4" - 6"



DESIGN FEATURES:

- Unique Adjust-O-Seal® feature allows in-line valve adjustment to compensate for normal wear on valve seats
- **SI SERIES VALVES DO NOT HAVE O-RINGS**
- Valves are a three-piece "swing-out" body design
- Upstream and downstream bubble-tight sealing capability allows valve body cleaning, purging, and draining
- Stem assembly accommodates IMI PBM Direct Mount Actuation for accurate alignment and increased cycling life
- Forged and cast valves are low-controlled ferrite
- True-Bore® (valve bore same as connecting tubing) – no puddling (Except 1/4" & 3/8")
- ASME BPE compliant
- USP Class VI elastomers and FDA compliant materials
- Valves are rated to full vacuum
- Material Test Report (MTRs) provided for wetted components
- Surface finishes are achieved without the use of ADIs (Animal Derived Ingredients)

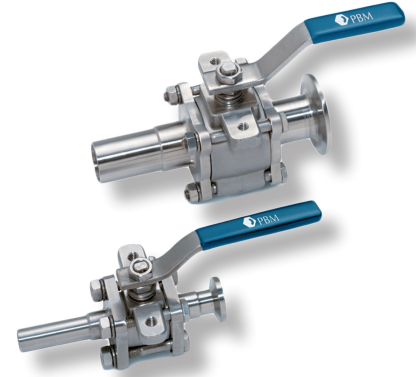

SPECIFICATIONS	2-Way Valves
Sizes	1/4" - 6" Series 9, 1/2" - 4" Series 8 (1/4" & 3/8" in Series 8 is Ext. tube only)
Material	Low ferrite cast and forged 316L material. Castings (Series 9) comply with A351, Alloy CF3M and/or A479, Alloy S31603. Forgings (Series 8) comply with A182, Alloy F316L/1.4404 and/or A479, Alloy S31603. Also available are Hastelloy™, AL6XN™, others available
End Connections	Extended tube, hygienic clamp, please refer to PB-CE89 for compression ends, others available
Seats & Seals	White V-TEF™ standard, others available
Stem Packing Material	V-TEF™ and S-TEF®, others available
Body Bolts & Nuts	18-8 Stainless Steel standard, special bolting optional
Maximum Working Pressure	See table below
Temperatures	Up to 450°F depending on seat and seal material
Finish	Standard internal finish of 20 Ra ID Series 8 (SF1), 30 Ra ID Series 9 (SF3), other finishes available

CV Values (gpm), Series 8/Series 9		
Size	End Connections	
	F-	X-
1/4"	1.5	1.9
3/8"	4.4	5.4
1/2"	6.5	8
3/4"	23	28
1"	55	65
1-1/2"	160	193
2"	365	420
2-1/2"	700	800
3"	900	1,040
4"	1,800	2,080
6"	4,200	5,000

ID Surface Finish, Ra Readings for Valves per ASME BPE		
Surface Finish	IMI PBM Polish Code	µ-in.
Mechanical Polish		
SF 1	A	20
SF 2	A	25
SF 3	-	30
Mechanical Polish and Electropolish		
SF 4	G	15
SF 5	F	20

316L S/S Pressure Ratings at Ambient (PSIG)		
SIZE	SERIES 8	SERIES 9
1/4"	600	900
3/8"	600	900
1/2"	600	900
3/4"	600	900
1"	600	900
1-1/2"	600	900
2"	600	720
2-1/2"	600	720
3"	600	720
4"	600	720
6"	N/A	250

Sanitary clamps & gaskets may limit pressure ratings to less than shown above. Foreign regulatory agencies may also limit the pressure ratings above.

How To Order:

PRODUCT (1-2) MATERIAL (3-4)		SIZE (5) SERIES (6)	END CONNECTIONS (7-8)		SEAT & SEAL (9)	PURGE PORT BALL OPTIONS	BALL & STEM (12)	OPERATOR (13-14)	POLISH OPTIONS (15)								
SI	HL	Cast (Ser. 9) 316L S/S	A	1/4"	9	F-	Ext. Butt weld for Tube	G	V-TEF™ Seats / Seals	--	No Purge Port or Ball Option	-	Standard Ball and Stem	--	W/ Standard Lever Handle	-	30 Ra ID (Std. Series 9)
	HF	Forged (Ser. 8) 316L S/S	B	3/8"	8	FX	Ext. Butt weld for Tube by Hygienic Clamp	J	V-TEF™ Seats / Seals VTFE Cavity Fillers	-8	Self Flushing Ball	F	Internal / External Grounding	02	W/O Handle W/ Stem Actuator Prep	A	20 Ra ID (Std. Series 8)
		Other material options available - Contact PBM.	C	1/2"		X-	Hygienic Clamp	H	S-TEF® Seats / Seals	-V	Slotted V-Ball	G	17-4PH Stem	04	Locking Lever Handle	D	15 Ra ID
			D	3/4"		G-	Female Cherry Burrell			-W	30° V-Ball			08	Gear Operator (Req'd for 6")	E	10 Ra ID
			E	1"		H-	Male Cherry Burrell			-X	45° V-Ball			16	Extended Handle (1/2" thru 4")	F	20 Ra ID after Electro Polish
			G	1-1/2"				I	S-TEF® Seats / Seals VTFE Cavity Fillers	-Y	60° V-Ball			19	Extended Oval Handle (1/2" thru 2")		
			H	2"				K	UHMWPE Seats / Seals	Other Purge Port & Ball Options - Contact PBM.				20	DA 80psig actuator	G	15 Ra ID after Electro Polish
			J	2-1/2"				L	UHMWPE Seats / Seals VTFE Cavity Fillers					27	DA 60psig actuator		
			K	3"										34	SR 80psig actuator	H	10 Ra ID after Electro Polish
			L	4"										41	SR 60psig actuator		
			M*	6"													

* Not available in forged.

Other seat/seal options available - Contact PBM.

Other operator options available - Contact PBM.

More polish available - Contact PBM.

IMI PBM Igenix® Cast Series 9/Forged Series 8 Manual

2-Way Valve with Locking Handle

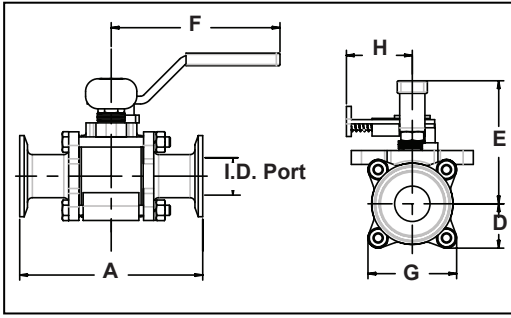

2-Way Valve with Extended Lockable Handle

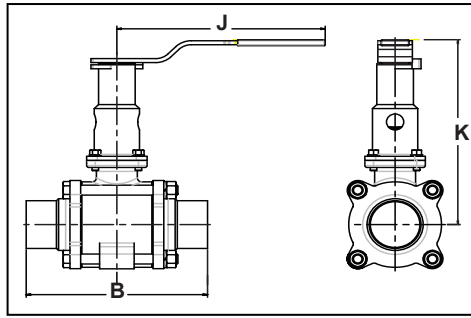

2-Way Valve with Gear Operator (6" only)

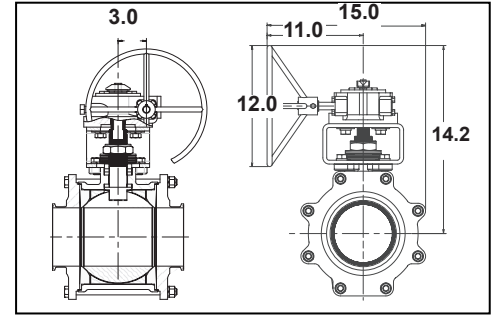

2-Way Sanitary Dimensioned valves in inches										Locking Handle		Ext. Lockable Handle		
Valve Size	Size Code	I.D. Port	A	B	D	E	F	G	Approx. Wgt (lbs)	H	Hole Dia. for Lock	J	K	Hole Dia. for Lock
1/4"	A	0.18	3.50	5.50	0.75	2.05	4.00	1.50	1.10	1.55	0.28	5.09	4.00	0.31
3/8"	B	0.31	3.50	5.50	0.75	2.05	4.00	1.50	1.10	1.55	0.28	5.09	4.00	0.31
1/2"	C	0.37	3.50	5.50	0.75	2.05	4.00	1.50	1.10	1.55	0.28	5.09	4.00	0.31
3/4"	D	0.62	4.00	6.00	0.85	2.23	4.00	1.68	1.40	1.55	0.28	5.09	4.14	0.31
1"	E	0.87	4.50	6.50	1.09	3.01	4.15	2.18	2.70	1.62	0.25	5.09	5.44	0.31
1-1/2"	G	1.37	5.50	7.50	1.68	5.02	8.81	3.31	8.90	2.57	0.38	8.00	7.46	0.31
2"	H	1.87	6.25	8.00	2.15	4.47	8.03	4.30	15.0	2.57	0.38	8.00	7.74	0.31
2-1/2"	J	2.37	8.00	11.50	2.79	6.51	12.06	5.58	36.0	3.47	0.38	12.06	9.36	0.31
3"	K	2.87	8.00	10.50	2.78	6.77	12.06	5.58	33.0	3.47	0.38	12.06	9.61	0.38
4"	L	3.83	10.00	13.00	3.66	7.53	12.06	7.33	67.0	3.47	0.38	12.06	10.38	0.38
6"*	M	5.78	13.00	17.00	6.18	NA	NA	12.37	164.0	NA	NA	NA	NA	NA

*Cast Series 9 Only

ACTUATED DIMENSIONS

Unit of Measure = inches
Dimensions based on actuators used with V-TEF™ seats.

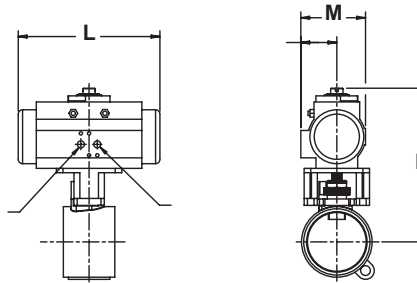

Size	80 PSI Spring Return					60 PSI Spring Return					60, 80 PSI Double Acting				
	L	M	N	P	R	L	M	N	P	R	L	M	N	P	R
1/4"	5.55	2.80	5.45	1.61	1/8 NPT	6.46	3.17	5.90	1.77	1/8 NPT	5.55	2.80	5.45	1.61	1/8 NPT
3/8"	5.55	2.80	5.45	1.61	1/8 NPT	6.46	3.17	5.90	1.77	1/8 NPT	5.55	2.80	5.45	1.61	1/8 NPT
1/2"	5.55	2.80	5.45	1.61	1/8 NPT	6.46	3.17	5.90	1.77	1/8 NPT	5.55	2.80	5.45	1.61	1/8 NPT
3/4"	5.55	2.80	5.59	1.61	1/8 NPT	6.46	3.17	6.04	1.77	1/8 NPT	5.55	2.80	5.59	1.61	1/8 NPT
1"	6.46	3.17	6.51	1.77	1/8 NPT	8.27	3.72	7.22	2.07	1/8 NPT	5.55	2.80	6.06	1.61	1/8 NPT
1-1/2"	9.47	4.17	9.65	2.30	1/8 NPT	10.83	4.85	10.16	2.68	1/4 NPT	8.27	3.72	9.10	2.07	1/8 NPT
2"	10.83	4.84	10.45	2.68	1/4 NPT	13.11	5.39	11.80	2.87	1/4 NPT	8.27	3.72	9.39	2.07	1/8 NPT
2-1/2"	13.11	5.39	13.48	2.87	1/4 NPT	14.65	5.83	13.96	3.15	1/4 NPT	13.11	5.39	13.48	2.87	1/4 NPT
3"	14.65	5.83	14.21	3.15	1/4 NPT	16.85	6.46	15.10	3.44	1/4 NPT	13.11	5.39	13.73	2.87	1/4 NPT
4"	16.85	6.46	15.86	3.44	1/4 NPT	19.69	7.36	16.80	3.94	1/4 NPT	13.11	5.39	14.51	2.87	1/4 NPT
6"	22.78	8.54	23.02	4.29	1/4 NPT	22.46	11.42	27.74	5.71	1/4 NPT	22.78	8.54	23.02	4.29	1/4 NPT

Manual Valves with Tube Ends when used with insulation		
Tube OD	Insulation max with no extension	Insulation max with extension
0.50	0.76	2.68
0.75	0.79	2.72
1.00	1.45	3.88
1.50	3.10	5.57
2.00	2.31	5.60
2.50	4.00	8.88
3.00	4.08	8.88
4.00	4.35	9.12



www.PBMValve.com

PBM, Inc. • 1070 Sandy Hill Road, Irwin, PA 15642

Phone: 800.967.4PBM • 724.863.0550

E-mail: info.pbmvalve@imi-critical.com

