

## Rear Track Hub Maintenance Instructions

To ensure maximum life and performance from your Phil Wood track hub(s), periodic maintenance is required. If you are not comfortable with performing any of the following instructions, contact our sales or service department and we will do our best to find a bicycle shop in your area that will be able to assist you. (See Service Information at the end of these instructions)

On the backside of this page, you will find a diagram showing the assembly order and part names we will be using in these instructions.

In general, you should perform these basic maintenance tasks a minimum of every three months. Actual frequency may vary depending on riding conditions and the amount of use. Failure to maintain your hub could result in premature failure and will void the hub warranty. Please visit [www.philwood.com/support](http://www.philwood.com/support) for up-to-date product care instructions, warranty, service and return policy information. Thank you for your support.

### TOOLS NEEDED:

6 mm Hex Wrench

8 mm Hex Wrench

Torque Wrench (recommended, not required)

Chain Whip

Phil Wood Lockring Tool (Classic Phil Shop Track Lockring Tool, for classic locking: Part# UG-LRP), (Pro Phil Shop Track Lockring Tool, for pro locking: Part# UG-LRQ) or other compatible lockring tool

Mild Degreaser (cleaning/rubbing alcohol)

Small, soft brush

Phil Wood Tenacious Oil (Phil Wood Part# LTO000)

Phil Waterproof Grease (Phil Wood Part# GPT000)

### Part 1: Securing End Caps and Bolts

1. To tighten end caps that have already been installed on your track hub(s), insert an 8 mm hex wrench into both end caps (G) and simultaneously turn clockwise, tightening them to 22 N-m.
2. If you are installing new end caps onto your track hub, it is best to first clean the threads on your axle. Do this by using a mild degreaser and a small, soft brush to clean grease, oil and dirt from the axle threads. (Avoid flushing degreaser into bearings.)
3. Using a clean, dry towel and mild degreaser, wipe down the axle threads and end caps.
4. After cleaning, let the parts dry completely before continuing.
5. Apply 1 drop of Phil Tenacious Oil to the axle threads and hand tighten the end caps back on to the axle.
6. Insert an 8 mm hex wrench into both end caps (G) and tighten them to 22 N-m.
7. Rotate the end cap clockwise and then counter-clockwise to ensure the axle and bearings turn smoothly and are functioning normally.
8. Before reinstalling the track bolts (A) into the hub, make sure that the threads are clean and undamaged. Installing dirty and/or damaged bolts into your track hub axle can result in axle damage. You can clean the bolt(s) with a mild degreaser and a small, soft brush as you did with the axle threads.
9. After the bolts are clean and dry, apply 4-6 drops of Phil Tenacious Oil onto the track bolt threads (A) and hand tighten the bolts into the axle.  
-Rear bolts (A) and rear washers (B) come as two separate parts. You will need to slide the rear track washer onto the bolt before installing the bolt back into your rear track axle.

**PLEASE NOTE:** When installing the rear washer (B) onto the rear track bolt (A), make sure that the orientation matches the diagram on the back of these instructions. The knurling on the rear track washers (B) should be facing the hub.

10. After properly installing your rear track wheel into your frame, insert a 6 mm hex wrench into both bolts (A) and simultaneously turn clockwise, tightening them to 25 N-m.

### Part 2: Phil Wood Track Cog and Lockring Installation

**PLEASE NOTE:** We recommend using only a Phil Wood track cog and lockring with our track hubs. Some manufacturers produce cogs and lockrings that are not ideal due to their varied thickness and thread depth. Installing another manufacturer's track cog or lockring will void the warranty on your hub.

1. Use a mild degreaser and a small, soft brush to clean grease, oil, and dirt from the hub's track cog thread (D), lockring thread (E), and the threads in your track cog (H) and lockring (I). (Avoid flushing degreaser into bearings.)
2. Using a clean, dry towel with mild degreaser, wipe down the threads (D,E) and the threads in the track cog (H) and lockring (I).
3. After cleaning, let the parts dry completely before continuing.
4. Inspect the threads on the track hub (D,E) and the threads in the cog (H) and lockring (I) for damage or dirt that might still be left behind after the initial cleaning. Existing damage to any of the threads could transfer onto new or undamaged parts (if you see something damaged, do not continue with the installation; replace the damaged part before proceeding). Damage can also occur if you try installing any parts with dirt or debris on them.
5. Apply a fresh coating of Phil Wood Waterproof grease to the track cog thread (D), lockring thread (E), and the threads in the track cog (H) and lockring (I).
6. Carefully hand tighten the Phil Wood track cog (H) onto the hub's track cog thread (D) by turning it clockwise. The track cog should thread smoothly onto the hub. If it becomes difficult to thread on or stops, do not force the track cog on to the hub. Stop and inspect the hub and cog for any issues. Forcing the cog onto the hub could result in irreparable damage.
7. After hand tightening the cog onto the hub, use a chain whip to tighten the cog onto the hub the rest of the way. Do not over tighten.
8. Carefully hand tighten the Phil Wood lockring (I) onto the lockring thread (E) by tuning it counter clockwise. The track lockring should smoothly thread onto the hub. If it becomes difficult to thread on or stops, do not force the lockring onto the hub. Stop and inspect the hub and lockring for any issues. Forcing the lockring on to the hub could result in irreparable damage.

9. After hand tightening the locking onto the hub, use a Phil Wood Lockring Tool to tighten the locking the rest of the way.

**PLEASE NOTE:** After your first or second ride, double check that the track cog and locking are still tight. The track cog (H) may tighten down more after the first few rides due to additional torque from your legs. This could result in the locking no longer being flush with the cog. If you do not tighten the locking after the cog tightens down, it could strip the track cog or locking threads (D,E).

### Part 3: Additional Maintenance

1. Every few rides, make sure to check that your rear hub end caps are torqued to 22 N-m and your bolts are torqued to 25 N-m. They may loosen over time.
2. Every few rides, make sure to check that your track cog and locking are tight. They may loosen over time.

### Rear Track Hub Overview

- A. Rear bolt (Phil Wood Part# MBA40)
- B. Rear washer (Phil Wood Part# MBWR)
- C. Hub shell
- D. Track Cog Thread (1.370" x 24 tpi)
- E. Lockring Thread (1.32" x 24 tpi LH Thread)
- F. R8 bearing (Phil Wood Part# PWXR8)
- G. Rear end cap (Phil Wood Part# A2DBH13, for 120mm spacing)
- H. Track cog
- I. Lockring (Phil Wood Part# AAVLR0, for Classic Locking)

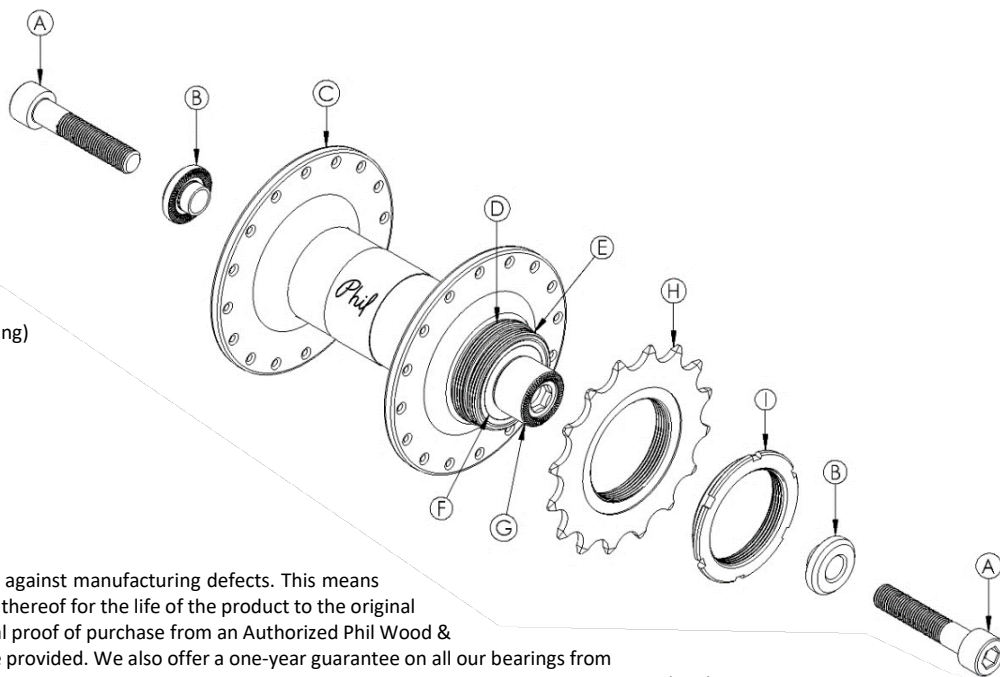

### Torque Specifications

- A. Rear bolt (torque to 25 N-m)
- G. Rear end cap (torque to 22 N-m)

### Limited Warranty

Phil Wood & Co. provides a limited lifetime warranty against manufacturing defects. This means that we offer a guarantee on material and production thereof for the life of the product to the original owner. In order to be considered for warranty, original proof of purchase from an Authorized Phil Wood & Co. Retailer/Dealer showing date of purchase must be provided. We also offer a one-year guarantee on all our bearings from the date of purchase. Bearings that fail due to contamination, misuse, improper tampering, or improper maintenance are not covered under warranty even if failure occurs within one year from date of purchase. **Please Note:** Our *Classic*, stainless steel cassette bodies have a one-year guarantee and our *Pro*, aluminum cassette bodies and all other *Pro*, aluminum parts have a one-year guarantee. All Phil Wood & Co. products have an intended purpose. Products used outside of that purpose will not be warranted and Phil Wood cannot be held responsible for any damage that may occur due to misuse. It is the end user's responsibility to examine the product on a regular basis to determine if it requires service and or replacement. (See included maintenance instructions for further information.)

### NOT COVERED UNDER THIS LIMITED WARRANTY ARE THE FOLLOWING:

1. Normal wear of parts that are subject to wear (e.g. bearings and ratchet mechanisms)
2. Incorrect re-assembly
3. Use in combination with other products that are not compatible (e.g. threading a FW onto the fixed side of a track hub)
4. Insufficient maintenance, tampering, misuse, and neglect.

\*Phil Wood & Co. does not cover the cost of shipping on repair or warranty items back to us beyond 90 days from the original purchase date.

### Return Policy

All returns, regardless of reason or cause, must have a return authorization number (RA#). We will not accept or process any item(s) without an RA#. Please contact us for RA# information via email at sales@philwood.com or call us at (408) 298-1540.

- RA#s are good for up to 60 days from the day they are issued.
- Items returned for credit are subject to a 15% restocking fee unless the item is returned due to our mis-shipment.
- Product and parts can be returned for credit (less restocking fee) if the product was never installed, used, altered, or damaged in any way. The return must be within 90 days of the original date of purchase.
- Items returned for exchange due to an ordering error are subject to a 15% restocking fee and all shipping fees for up to 30 days from the date of purchase.
- Product and parts returned more than 30 days after date of purchase can be returned for credit (less a 30% restocking fee) for up to 90 days from the day of purchase.
- After 90 days, item(s) may not be returned for credit or exchange.
- Customer is responsible for properly packaging the returning item(s).
- Customer is responsible for any damages incurred due to improper packaging. Customer is also responsible for shipping fees.
- Partial credit may be given for returned item(s) that suffered cosmetic damages resulting from installation or shipping. Eligibility for credit will be determined by Phil Wood & Co.'s warranty and technical personnel. Any damage to a product that may compromise the integrity of the part will void any applicable credit.

### Service Information

All services must have a return authorization number (RA#). We will not accept or process any item(s) without an RA#. Your issued RA# should be clearly written on the outside of your package so our service department can match your item(s) to the service information on file. Items sent to Phil Wood & Co. for service without a valid and legible RA# on the outside of the package will be REFUSED and returned to sender at their cost. (Depending on how busy our service department is, standard services can take 1-2 days to complete. Standard services can take longer to complete depending on service department workload and part availability.) Once issued, an RA# is valid for 60 days.

**PLEASE NOTE:** Items sent to Phil Wood & Co. for service without a valid and legible RA# placed on the outside of the package will be REFUSED and returned to sender at their cost. Phil Wood & Co. does not cover the cost of shipping on repair or warranty items sent back to us beyond 90 days from the original purchase date.