



Toll Free: 1-877-718-0808

www.revolveled.com

DUSK TO DAWN LED

Dusk to Dawn LED Barn Light / Street Light combines optical performance, energy efficiency and versatility to meet the needs of any area. Weatherproof and 3G vibration rated construction. This LED solution provides uniform and energy conscious illumination for buildings, barns, docks, rural streets, commercial and perimeter lighting. 120° Beam spread. Durable, die-cast aluminum housing, silver gray polyester powder-coat finish. Dusk to Dawn Photocell included. Mounts directly to wall surface or to pole with optional mounting arm.



PHOTOMETRICS:

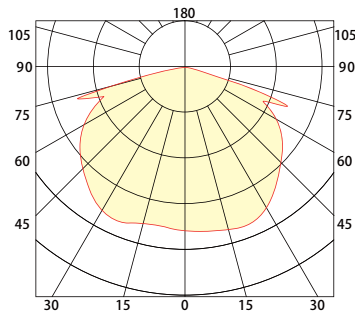

DIMENSIONS

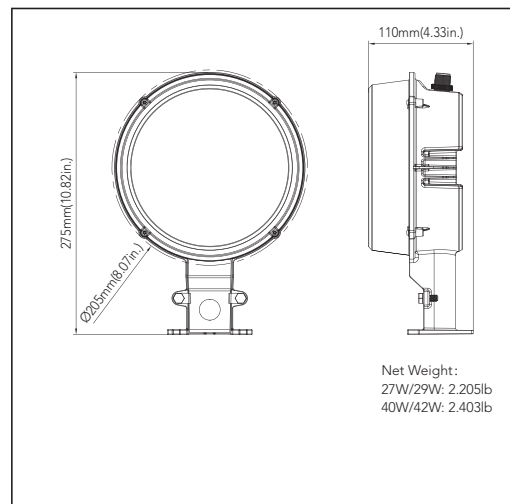

SPECIFICATIONS:

PART #:	Wattage	Lumens	0-10V Dim	Voltage	CCT	PF	THD	CRI	Weight
RDBL02030275KNPWMLF	27W	3850 LM	YES	120-277V	5000K	≥0.9	≤ 20%	> 70	2.2 lb
Silver Gray / Optional pole mounting arm									
Operating Temp:	-40°F to 122°F								
Lifetime:	> 50,000 hr								
Dimensions:	See Diagram with Mount								
Warranty:	5 Years								
Certifications:	UL Wet Certified								