

EV-ML-500XT

EXTERNAL IP RATED 500KG MAGNETIC LOCK

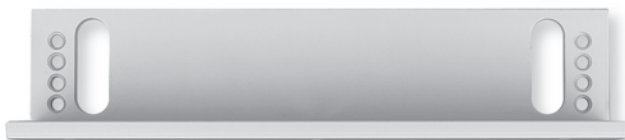

EV-ML-500XT Diagram

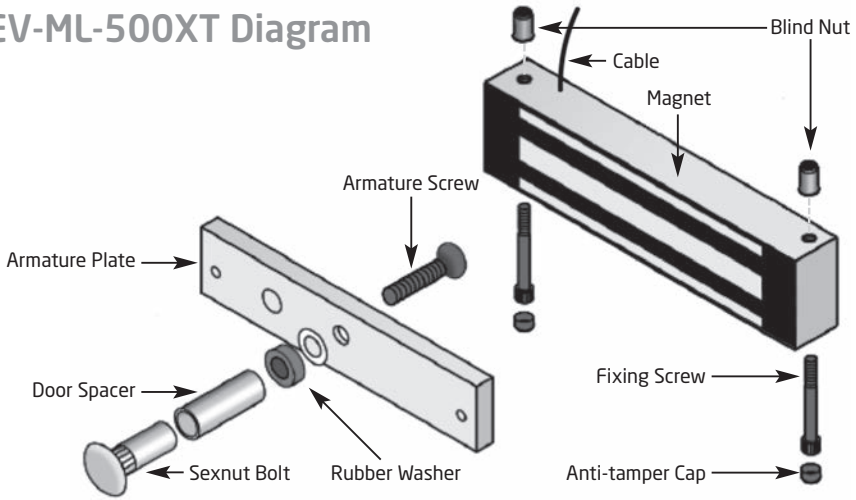

Mounting Configurations

Please identify the type of installation required, for example; which way the door/gate will swing. Refer to the installation diagrams for the blind nut, magnetic lock, bracket & armature to complete the install.

Standard mounting

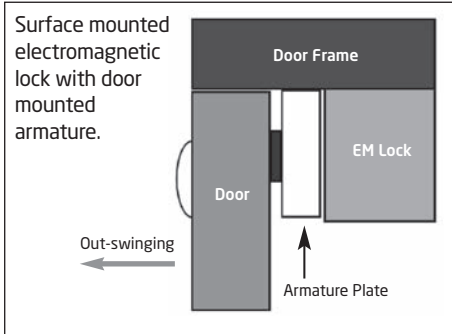

'L' Bracket mounting

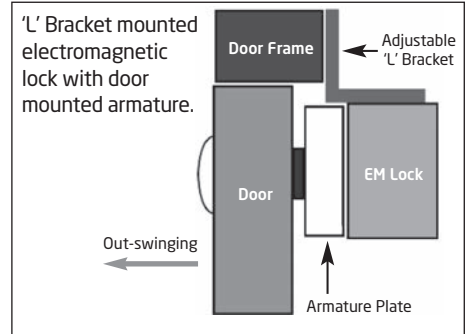

'Z' Bracket mounting

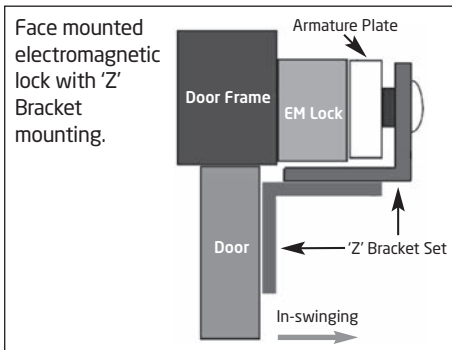

Swinging gate

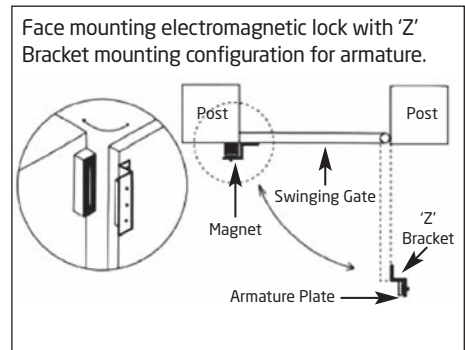

Sliding gate

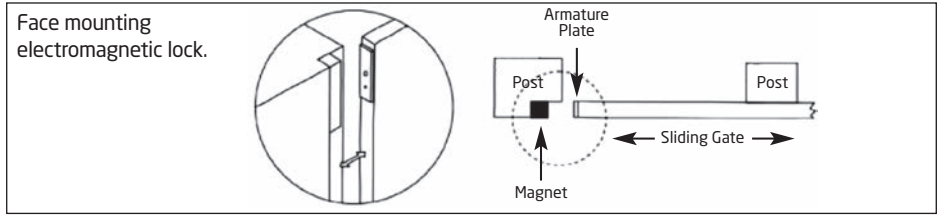

Installation Instructions

Blind nut installation x2

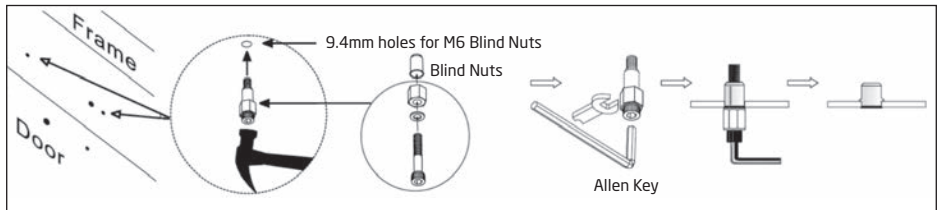

Blind nut and electromagnetic lock installation

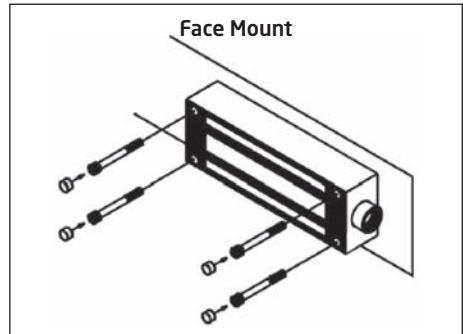
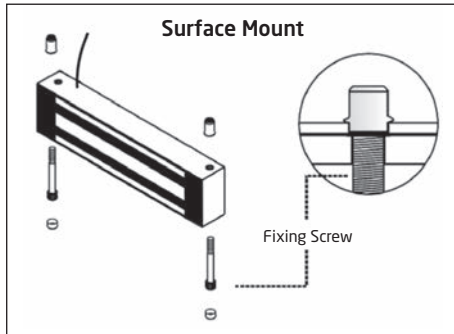

Blind nut and bracket installation

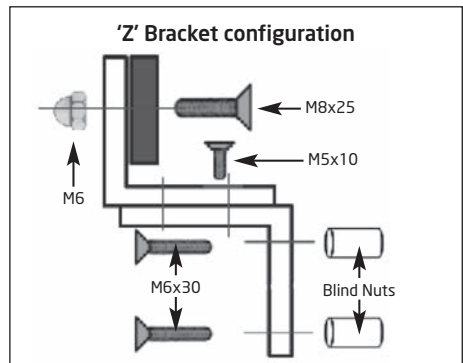
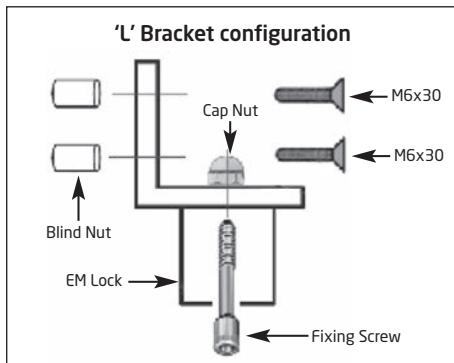

Armature installation

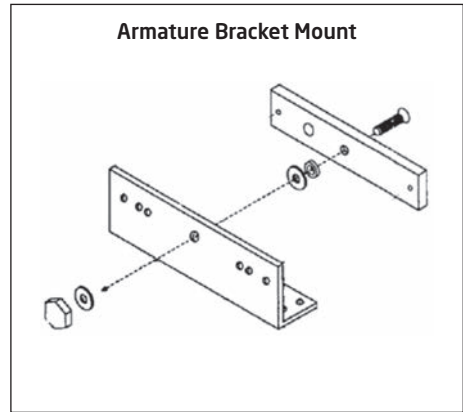
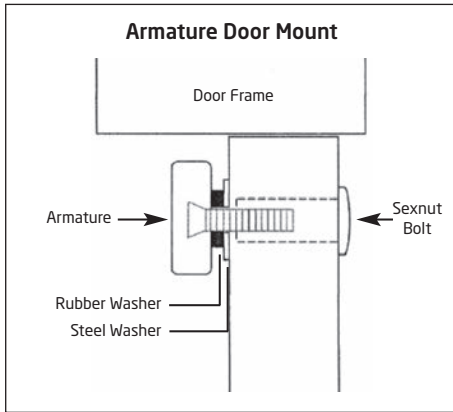

Wiring configuration

It is recommended to install the electromagnetic lock inside the property and conceal the cable inside the door frame to avoid unlawful entry.

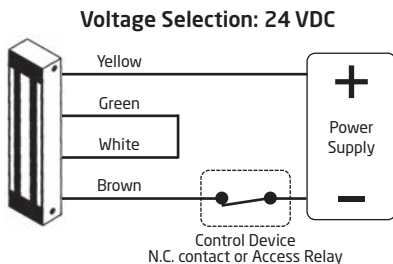
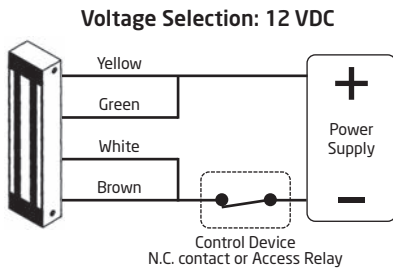

Rubber washer installation

The rubber washer allows the armature plate to pivot to compensate for door misalignment.

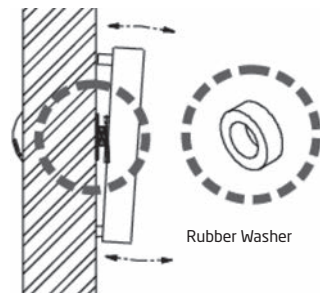

Fig. 8

Technical Specifications

Holding force	500kg / 1100lbs max
Housing	Stainless Steel
Weather resistant rating	IP67
Dual voltage	12 & 24 VDC
Current drawn	420mA @ 12VDC 240mA @ 24VDC
Safety approval	CE
Magnet Dimension	220(L) x 62(W) x 43(D)mm
Armature Plate Dimension	185(L) x 61(W) x 17(D)mm