

LE220 (-plus, R-plus, and Rsc) Setup & Instruction Manual

Instrument and Software Developed for High-performance Sample
Preparation using Adaptive Focused Acoustic® (AFA®) Energy

For Research Only

Model Numbers: LE220-plus, LE220R-plus, and LE220Rsc | Software: SonoLab 8



UNIVERSAL PRECAUTIONS

Universal Precautions should be followed on all specimen samples, regardless of whether a sample is known to contain an infectious agent. Laboratories handling specimen samples are advised to comply with applicable parts of the following government and clinical standards, or their equivalent in the country of use:

- Centers for Disease Control (CDC), Universal Precautions for Prevention of Transmission of HIV and Other Bloodborne Infections, published 1987, updated 1996
- Clinical and Laboratory Standards Institute (CLSI), GP17-A2 Clinical Laboratory Safety; Approved Guideline - Second Edition, published 2004, ISBN 1-56238-530-5
- Clinical and Laboratory Standards Institute (CLSI), M29-A3 Protection of Laboratory Workers from Occupationally Acquired Infections; Approved Guideline, Third Edition, published 2005, ISBN 1-56238-5674
- Occupational Safety and Health Administration (OSHA), 29 CFR 1910.1030 Bloodborne Pathogens
- International Standards Organization (ISO) 15190:2003 Medical Laboratories – Requirements for Safety

Trademarks

Patented or patent pending and registered or registration-pending trademarks of Covaris are protected.

Registered names and trademarks used in this document, even when not specifically marked as such, are not to be considered unprotected by law.

WCS and AFA are either registered trademarks or trademarks of Covaris, Inc. in the United States and/or other countries. Teflon is a registered trademark of The DuPont Company.

Information subject to change without notice

For Research Use Only (RUO)

Not for use in Diagnostic Procedures Publication

PN 010398

Revision H, November 2019

Product covered by Patent No. US6, 719,449, US6, 948,843, and other pending applications 2019©

Covaris Inc., All Rights Reserved

Covaris, Inc.

14 Gill St, Unit H Woburn,

Massachusetts 01801-

1721 USA

Warnings

For the Safety of Operating Personnel:

- Make sure that the equipment is properly grounded. *DO NOT* operate if it's not properly grounded.
- The unit is equipped with a power plug appropriate for the destination country. *DO NOT*, under any circumstances, remove the grounding prong from the power cord.
- *DO NOT* run an acoustic treatment with the sample cover in the OPEN position or without a water bath - the acoustic system will not work.
- If there is any indication that the Safety System is not functioning properly, *DO NOT* operate the equipment and contact Covaris immediately.
- If the equipment is used in a manner not specified by the manufacturer, the protection provided by the equipment may be impaired.

To Prevent Damage to the Equipment:

- The instruments are designed to operate in ambient laboratory conditions e.g., 19 to 25 °C (66 to 77 °F). *DO NOT* operate the instrument in a cold room environment. The system is designed to operate with a water bath and re-circulating heater/chiller apparatus to control sample temperature.
- *NEVER* run a method without water in the bath since this could damage the transducer. The instrument is equipped with a water level sensor to protect the transducer and degassing pump. The system will not allow the degassing pump to operate or the acoustic treatment to start unless an adequate volume of water is detected.
- Distilled or deionized water should be used to fill the water bath.
- Unless a Water Conditioning System 3.0 (WCS) is actively employed, empty the water bath and wipe it dry *EVERY DAY* with a lint-free cloth. *DO NOT* leave water in the tank for an extended time as there is no water filtration or water cleaning system within the apparatus (unless WCS is employed).
- *DO NOT* employ isopropyl alcohol, ammonia-based or abrasive cleaners in the system, as these will damage the acrylic surfaces.
- Establish a standard of operation and test the equipment periodically, as described in the maintenance section of this manual.

CAUTION: All WCS 3 components have pressure ratings above Covaris' specified maximum operating pressure which have been extensively tested. However, if plant DI water is connected to the WCS, a catastrophic failure may result in substantial plant water spillage. *It is the user's responsibility to specify and implement appropriate containment/alarm schema for their facility.*

Warranty

When used in accordance with written instruction and under normal operating conditions, the Covaris instruments are guaranteed to be free of defects in MATERIAL and WORKMANSHIP for one (1) year from the date of original delivery by an authorized representative. Any component proven defective during the stated period will be repaired free of charge or replaced at the sole discretion of Covaris, F.O.B., Woburn, Massachusetts, U.S.A. provided that the defective component is returned properly packaged with all transportation charges prepaid. The customer is expected to perform basic diagnostics and component replacement via telephone support from Covaris personnel. If Covaris personnel are required to perform on-site repair, all travel related costs are paid by the customer. A limited warranty as specified may apply to certain components of the equipment.

Warranty Exceptions

This warranty is void if failure of the software or hardware has resulted from accidents, abuse, improper maintenance or repair, or by misapplication from the customer. It is also void if damage is caused by any unauthorized attachments or if modifications are made to the equipment. Removing or tampering with the Safety Enclosure will void the warranty, and the customer will assume all liabilities.

This warranty is limited to the original purchaser and is not transferable.

The software will perform according to the accompanying written materials and the medium on which the software is delivered is free of defects in materials under normal use and service. The warranty is void if damage has resulted from third party software not intended for use with the system.

The high-power focused transducer is designed to give maximal mechanical energy output in water. Permanent damage to the transducer and electronic circuits could result if the transducer is operated without water. Operation of the system without water in the water bath voids the warranty.

CONTACT COVARIS, INC. SHOULD YOU HAVE QUESTIONS OR CONCERNS PERTAINING TO THE USE OF OUR EQUIPMENT.

Warranty Services

The purchased equipment is covered by a twelve (12) month warranty which includes all the necessary services and support necessary so that the customer can successfully operate their equipment. Extended warranties are available at the end of the original 12 month warranty period.

Services included with the original purchase of the system are:

Technical Support – Ongoing assistance with the operation or application of the equipment and/or troubleshooting is provided via:

- Telephone
 - United States: Tel: +1 781.932.3959 during the hours of 9:00 a.m. to 5:00 p.m., Monday through Friday, Eastern Standard Time (EST), Greenwich Mean Time (GMT-05:00)
 - Europe: Tel: 44 (0) 845 872 0100, during the hours of 9:00 a.m. to 5:00 p.m., Monday through Friday, Greenwich Mean Time
- E-mail queries to techsupport@covaris.com or applicationsupport@covaris.com

Parts Replacement – Replacement of parts (excluding consumables) from normal operation of equipment are provided on a priority basis. All labor and shipping charges are included. Failure due to accident, abuse, or improper operation is not covered.

This manual includes maintenance guidelines and troubleshooting tips.

Table of Contents

1. Introduction	6
1.1 Overview of the Instruction Manual	6
1.2 The LE220-plus Instrument.....	6
1.3 The LE220R-plus Instrument	6
1.4 The LE220Rsc Instrument	6
2. Installation and Setup	7
2.1 Assembly.....	7
3. Getting Started.....	11
3.1 Fill the Water Bath.....	11
3.2 Start the System	11
3.3 Preparing your System for Use.....	13
3.4 Running a Method.....	22
3.5 Daily System Shutdown	23
4. Create and Edit Methods	24
4.1 Create New Method	24
4.2 Creating Methods using Repeat Function	30
4.3 Scanning Treatments (LE220Rsc Only)	33
4.4 Modifying Existing Methods.....	34
5. SonoLab™ Application Software	35
5.1 Home Screen	35
5.2 History Tab	35
5.3 About Tab	37
5.4 Admin Tab	38
6. System Specifications.....	42
7. Maintenance	43
7.1 Cooling Air Intake	43
7.2 Water Bath	43
7.3 Transducer	44
7.4 Safety System	44
7.5 Degassing System	44
7.6 Cleaning the System	44
7.7 System Shutdown.....	44
8. Troubleshooting	46
9. Appendix	48
Appendix A: LE220R-plus (LE220-plus) Series Site or Transport Preparation	48
Appendix B: Installing SonoLab 8 and Required Support Software	49
Appendix C: Humidity and Water Management for the Covaris LE220-plus	54
Appendix D: Connecting AutoFill to Plant Water	56
Addendum for LE220Rsc.....	57

1. Introduction

1.1 Overview of the User Manual

This manual contains operation and maintenance instructions for the Covaris LE220-plus, LE220R-plus, and LE220Rsc Focused- ultrasonicators. This document contains information essential to the proper use and care ,of your equipment. Should any unforeseen problems occur with the normal operation of the equipment, contact Covaris Technical Support immediately.

The following definitions apply in this manual:

NOTE: Inconvenience if disregarded.	WARNING: Personal injury may occur.	CAUTION: Equipment damage may occur.
--	--	---

There is also a PDF version of this manual, typically available on the computer desktop. Open the manual by double clicking the user manual icon.

1.2 The LE220-plus Instrument

The LE220-plus Focused-ultrasonicators are based on Covaris Adaptive Focused Acoustics (AFA) technology. These instruments are designed to provide researchers an integrated stand-alone tool to be used in a laboratory environment. The instrument is ideal for those who work with tissue homogenization, cell lysis, DNA or chromatin shearing, and other sample preparation steps.

The system is comprised of the:

- *Treatment System* which delivers the acoustic energy to the sample
- *Safety System* which protects users from inadvertently contacting the high intensity acoustic energy
- *Computer and Application Software* which provides an interface to control the device via the API
- *Water Management System;* which consists of a cooler/heater and a UV treatment chamber with particulate filter to maintain water quality in the instrument bath

1.3 The LE220R-plus Instrument

In addition to the features of the LE220-plus described above, the LE220R-plus is designed to be integrated with a sample handling robot in an automated work cell. The front door of the safety enclosure contains a cutout providing the robot arm access to the inside of the LE220R-plus cabinet. The LE220R-plus presents the sample tray at the opening, and the robot arm loads or unloads the sample through the opening. The LE220R-plus is controlled by custom software built using the Covaris Integration Toolkit.

A light curtain has been added as an additional safety interlock. The light curtain is wired into a safety rated relay controller the output of which is connected to the Covaris controller board. If an operator reaches through the robot access opening while the system is running, motor power and acoustics are immediately disabled.

The light curtain consists of invisible, infrared light and an infrared detector. Beams of light on 14 mm spacing are transmitted between the source and detector. Blocking one or more beams of light trigger the safety interlock system. Acoustics and motion will remain paused until the beams are unobstructed.

1.4 The LE220Rsc Instrument

The LE220Rsc is an enhanced version of the LE220R-plus. In addition to the features of the LE220-plus and LE220R-plus, the LE220Rsc contains an extended travel X axis motion stage. This longer travel stage allows treatment of 96 and 384 position well plates using the Covaris scanning treatment method.

2. Installation and Setup

2.1 Assembly

The following items should be found in the crate containing the instrument:

- Main unit
- Notebook computer with AC adapter
- Cables
 - USB cable
 - Instrument power cord
 - Computer AC adapter power cord
- Accessories
 - AFA ultraCUBE, consisting of:
 - Water Conditioning System 2.0 (WCS)
 - CH05 Chiller
 - Chiller hose kit
 - Sample tubes & racks (varies by application)
 - Water tank (installed in main unit)
 - AutoFill accessory kit



LE220-plus Focused-ultrasonicator



LE220R-plus Focused-ultrasonicator

- 2.2.1 Unpack the instrument, the Water Conditioning System 2.0 (WCS), and the CH05 chiller. Refer to the WCS User Manual to install the quartz tube and UV lamp into the WCS. The quartz tube and lamp are shipped separately to prevent breakage during shipment. Arrange the instrument, WCS, and chiller on a bench as shown below. The chiller and WCS may be installed on either side of the system. The CH05 and WCS may also be placed on the floor, if they can be located such that the hoses reach the front of the water bath.

CAUTION: When positioning the system, please keep the fan and rear panel vents free of obstructions that may block the flow of air.

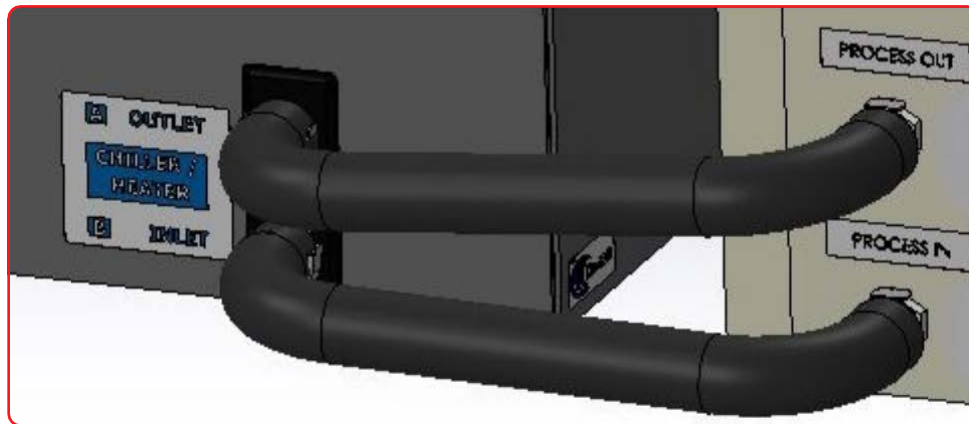
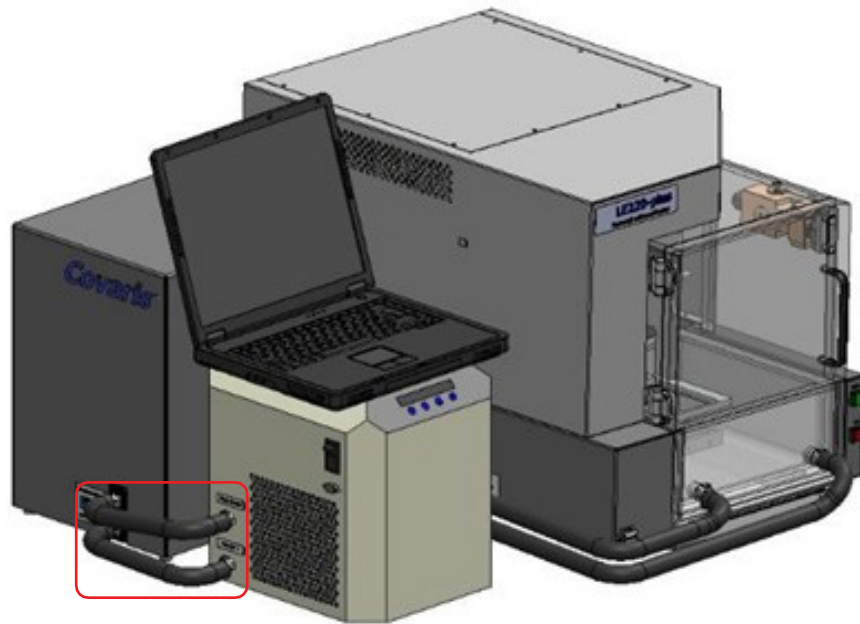

Connect the hoses between the WCS and the CH05 as shown above.

Connect the remaining two hoses between the two ports on your LE220R-plus or LE220-plus water bath and the remaining two ports on the opposite side of the WCS. It doesn't matter which bath port connects to which WCS port for these two hoses.

NOTE: See the addendum at the end of the manual for connecting the hoses to the LE220Rsc water bath. The connections are not interchangeable on the LE220Rsc.

The WCS contains a particulate filter and UV lamp to prevent biological growth. This allows the water bath to be changed just once per month. Refer to the User Maintenance section of this manual for details.

- 2.2.2 The AutoFill option allows plant deionized water to be plumbed directly to the LE220R-plus and LE220-plus to allow automatic filling of the water bath without any operator intervention. If the AutoFill option is going to be used, refer to the instructions included with the AutoFill accessory kit or *Appendix D* of this manual to assemble the components of the AutoFill Accessory Kit, and connect plant water to the system.
- 2.2.3 Plug the instrument into a power source using the enclosed line cord. The instrument is a “universal input” device and automatically employs any worldwide line voltage or frequency (100 to 240 volts AC, 50 or 60 Hz). Leave the instrument power and notebook power switched OFF at this time.
- 2.2.4 Plug one end of the USB cable into the instrument USB Port and the other end into any USB port on the notebook computer.
- 2.2.5 Connect the temperature control cable between the D-connector at the rear of the LE220-plus or LE220R-plus and the D-connector on the CH05 chiller.



- 2.2.6 Connect the CH05 to a power source. The CH05 is a universal input device. Do not turn on the CH05 at this time.
- 2.2.7 Locate the WCS power supply and line cord. Connect the WCS power supply to the port provided on the WCS and connect the line cord to a power source. The power supply is a universal input device. Leave the WCS turned off at this time.
- 2.2.8 Connect the computer to a power source. Connect the mouse or other accessories to the computer.
- 2.2.9 Refer to the rear of the instrument’s right-side panel and identify the following features as necessary:

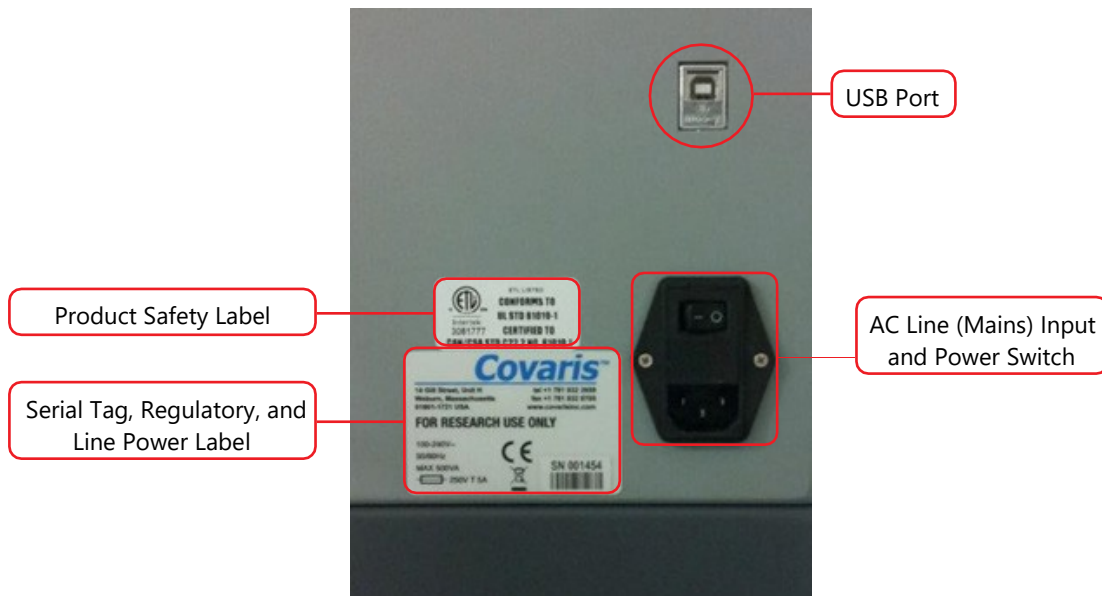

The Rear Right Panel of the System

2.2.10 Refer to the figure below and identify the following items:

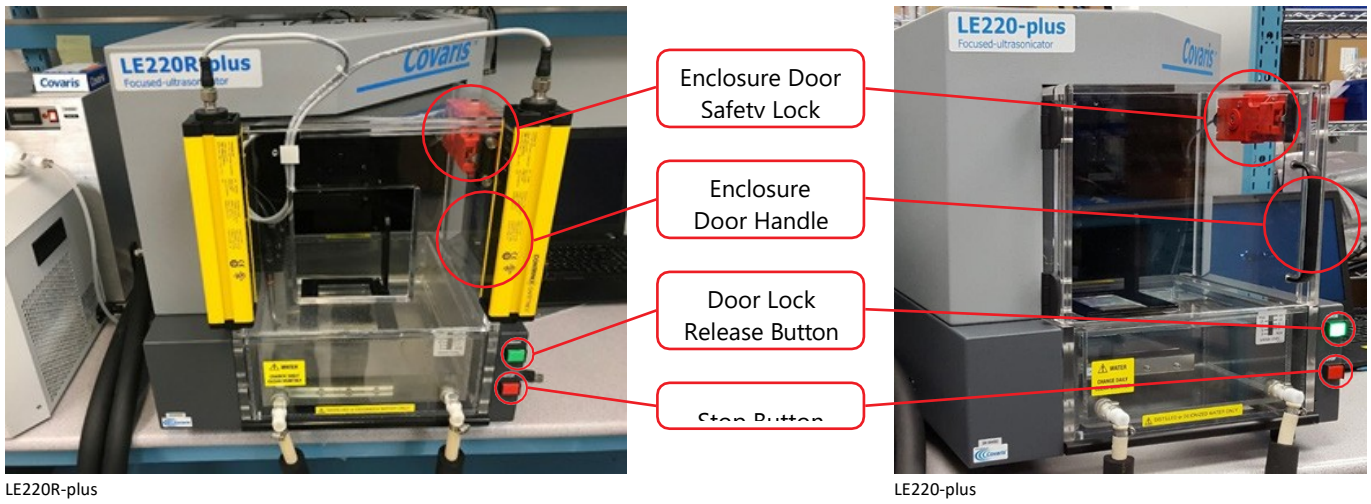

2.2.11 Power on the instrument using the power switch at the right rear, at the power entry module.

2.2.12 Press and hold the green 'Door' button while pulling the door handle to open the safety enclosure front door. Slide out the water tank and remove it from its plastic shipping bag. Remove and discard the desiccant pack.

The instrument is now ready to be started.

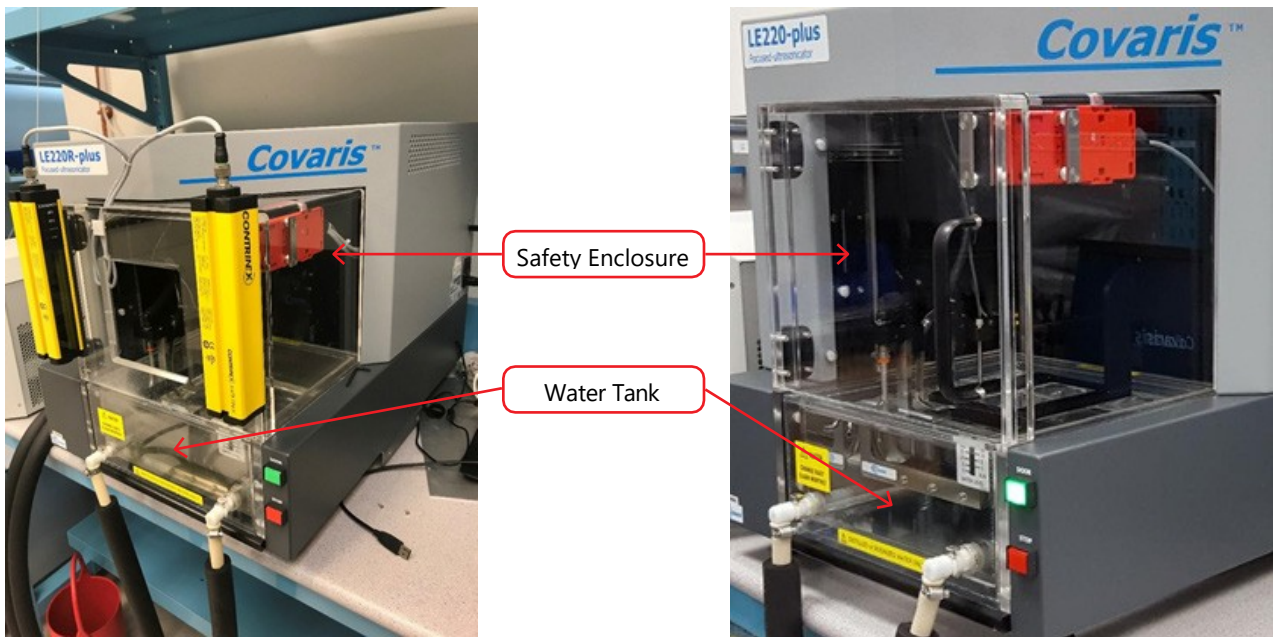

3. Getting Started

3.1 Fill the Water Bath

The instrument's transducer must be immersed in a water bath to transmit high-frequency, focused acoustic energy to the sample tube. For best performance, employ only clean, distilled or deionized water in the bath.

Open the front door, remove the tank and the first time your system is operated, fill the bath initially about half full. The first time the WCS and chiller is operated, a substantial amount of air is forced from the WCS into the bath, which may cause a full bath to overflow. This only occurs the first time an empty WCS is used.

Once the WCS is filled with water, the bath should be filled to a level of 15. If the transducer is in the raised position, out of the bath, fill to 15 on the "Fill" side of the gauge. If the transducer is submerged, fill to 15 on the "Run" side of the gauge.



If the AutoFill option is enabled, after the initial filling of the bath, AutoFill will maintain a sufficient water level in the bath automatically.

3.2 Start the System

Turn the instrument power ON using the power switch located on the rear, right side of the instrument at the power entry module. When power is ON, the green door-lock release switch will illuminate and the ventilation fans in the rear panels will run.



Power on the WCS and CH05 chiller. SonoLab software will perform its temperature control; it is not necessary to adjust temperature set points from the CH05 control panel.

The first time the chiller and WCS are operated, the WCS filter and UV treatment chamber are empty, and this air is purged as described above. This is normal, and only occurs the first time the chiller/WCS assembly are operated.

Start the system computer. The computer employs a Windows 10 (or later) Operating System.

SonoLab is an application used to control a Covaris Focused-ultrasonicator for processing a biological or chemical sample. It is designed to create, edit, and run a processing program called a method. It has provisions to run, pause or stop a method and view execution histories which contain a record of key instrument parameter values during a run. It also contains editors for customizing system settings and performing maintenance functions.

SonoLab is installed on the computer purchased with the instrument. No further installation or configuration is required.

Find the SonoLab icon on the desktop:



If the icon is not visible, or if SonoLab is not installed, please refer to *Appendix B* or contact the Covaris Technical Support for installation instructions.

Double-click on the *SonoLab icon* to start SonoLab; the splash screen will appear:



Following the splash screen, the SonoLab Home Screen will appear with the login dialog box in front of it.

SonoLab is preconfigured with a single administrative user named "Administrator" whose password is "admin". User Authentication and creating new users and their permissions are described in Section 5.4, the ADMIN Tab.

Enter the username and password and click 'LOGIN'



Following login, the motion system homing dialog appears:



Click 'Yes'. The transducer and sample holder mechanical assemblies will move into position and the SonoLab Home Screen will display.

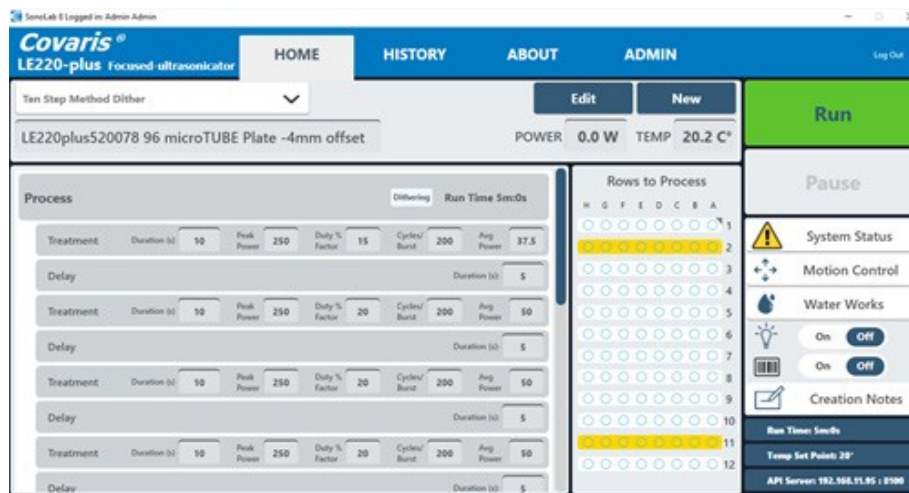

If SonoLab does not connect to the instrument, the following screen appears allowing SonoLab to be run in emulation mode without an instrument.

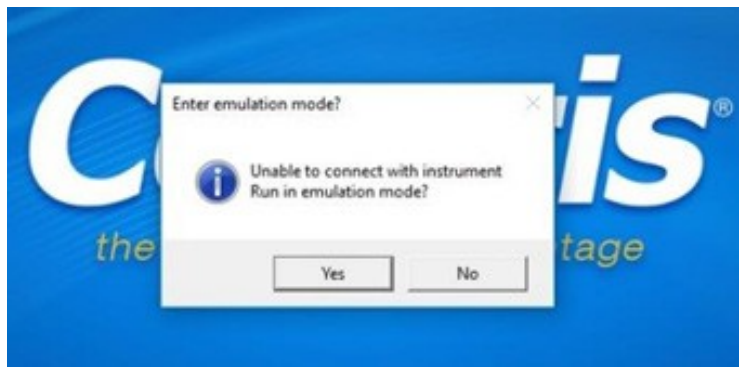

Click “Yes”, and the normal SonoLab login and Homing screens are presented, allowing the user to operate SonoLab as if an instrument is present. This is useful for training purposes or for creating methods off-line.

3.3 Preparing your System for Use

3.3.1 Instrument Status & Basic Controls

To run an acoustic treatment, a number of conditions must be met, including:

- a) The motion system must be initialized.
- b) There must be an acoustic method selected in the Method box.
- c) Water temperature must be within acceptable Min and Max limits.
- d) The bath water must be degassed.
- e) Water should be approximately at level 15.
- f) The safety enclosure door must be closed.

NOTE: The proper plate and consumables must be in place on your system’s sample tray.

The “Run” button will remain gray and inactive until a method is selected and all necessary conditions are met. Your system automatically sets the temperature when a method is selected. After a specific user’s initial log in, SonoLab will automatically select the last method run by this user the next time they log in. The bath water temperature will then be set according to this method.

To achieve an acceptable status on the other conditions:

- a) Your system’s motion system normally initializes when SonoLab starts, unless the user purposely skipped this step. In this case, the motion system can be homed from the Motion Control pane.

Click on the Motion Control button to display the Motion Control pane.

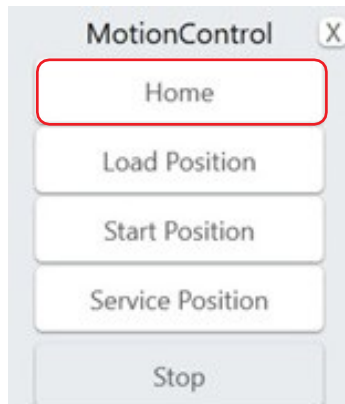

Click on “Home” to initialize the motion system. See additional information for the Motion Control pane in this section of the manual under ‘Other Controls on the Home Screen’.

- b) To select and load an acoustic method, click on the panel displaying the currently loaded method, as shown below, and a list of existing method names will be displayed in a drop-down list. Navigate through the list with the vertical scroll bar and select a method.

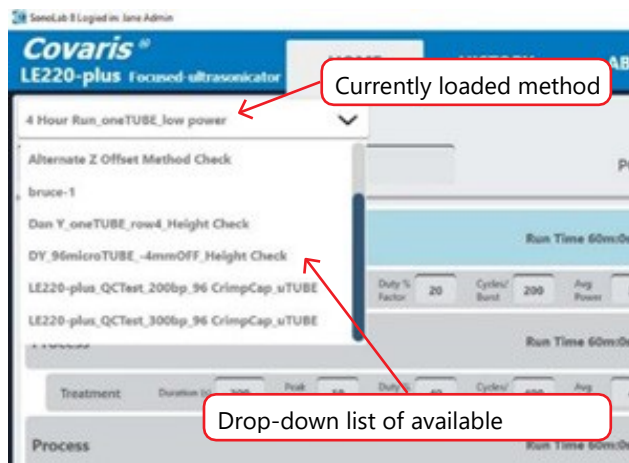

The method’s run time (minutes and seconds) and temperature set point will be displayed in the lower right corner of the main screen as shown.

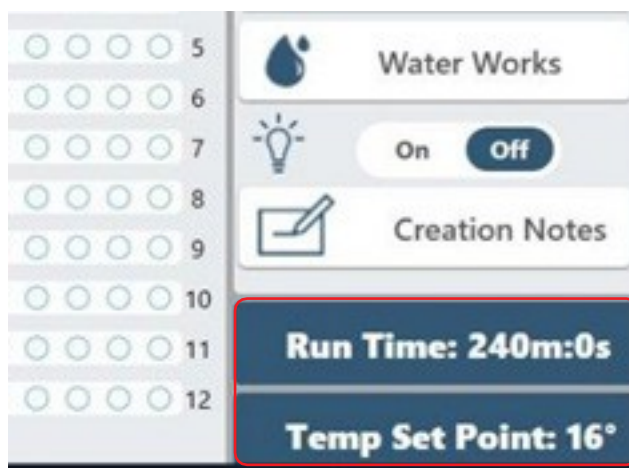

c) An important principal of the Covaris Focused-ultrasonicator is isothermal temperature control. Your system automatically adjusts the water temperature, as necessary, to match the method temperature set point once a method is selected. Water Temperature status will turn green when temperature is within the Min and Max limits (by default 5 degrees above or below the set point). The default set point (in the absence of a selected method) is 20 °C.

Bath cool down from room temperature to below 10 degrees takes about 30 minutes. Once a method starts, if the bath temperature rises beyond the user specified limit, your system finishes the current row being treated, pauses treatment, and automatically resumes when the temperature is back within limits, with no operator intervention required.

d) Properly degassed water is important for efficient transfer of acoustic energy from the instrument's transducer to the sample being treated. If water is detected in the bath, the degassing pump is automatically turned on when SonoLab is started. The pump should be allowed to run until the Degas indicator on the Status Screen turns green (60 minutes) prior to an acoustic treatment. The degas pump can be manually turned on and off from the Water Works pane. See additional information below in section Other Controls on the Home Screen.

e) When the "Run" button is clicked to start the method, SonoLab checks that the bath water is at an appropriate level for the consumables employed in the method. If the water level is incorrect, the method is paused and a message to adjust the water level is presented.

The remaining conditions, along with their related status, are displayed in the Instrument Status panel. Click the "System Status" button to display the Instrument Status panel. An acceptable condition is indicated by a green check mark in the Status box.

If a condition is not acceptable, the status will show X.

If any of the items other than "Water Level" and "Temperature within Limits" in the Status list display X, a red X will also be displayed in the System Status button, as shown below. Water level and temperature will be adjusted as necessary once a specific method is started.

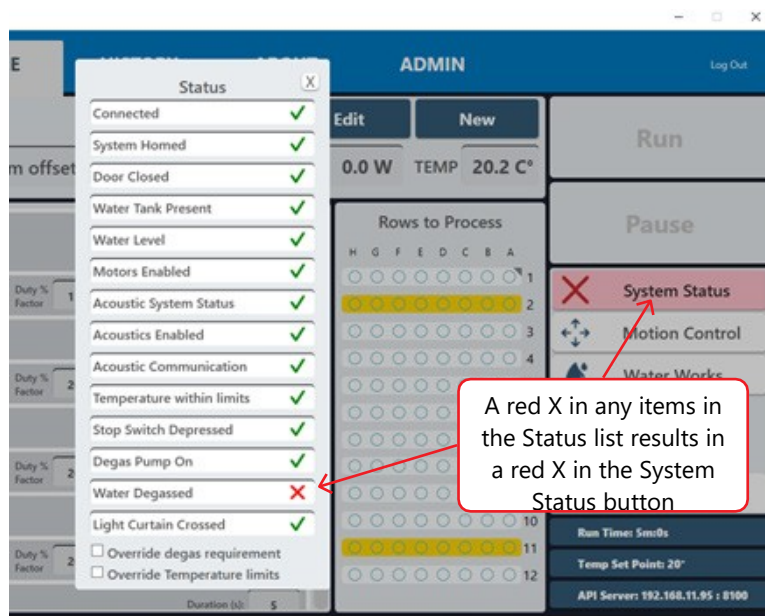

A checkbox is provided at the bottom of the status screen to override the degas timer and temperature limits to allow your system to run a method without waiting for these conditions to be met. With the temperature and degas override boxes checked, the display changes to yellow caution indicators as shown.

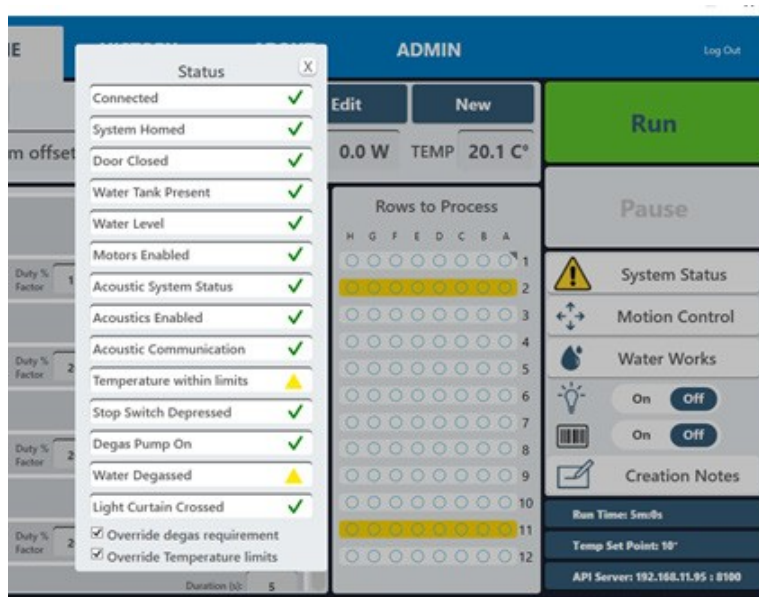

Once a method has been loaded and all conditions are acceptable, the 'Run' button will turn green and the selected acoustic Method can be started.

To modify an existing method, see Section 5 Create and Edit Methods.

3.3.2 Other Controls on the HOME Screen

- **Lightbulb:** This is both a control and indicator. The enclosure light is off when SonoLab starts. Clicking on the light bulb image will turn the light ON, clicking again will turn it OFF.
- **Barcode Scanning:** Your system allows barcoded samples to be scanned prior to treatment. The barcode data is then associated with the specific method run and stored in the both the .csv and .xhst history files found in Public Documents\Covaris\SonoLab 8\History.

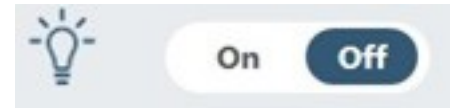

Plates, in which all tubes are integrated into a single assembly, allow a single barcode entry for the entire plate. Racks allow separate entries for each row to be treated by the method.

When the barcode scanning button is switched on, the green "Run" button changes to a yellow "Scan" button.

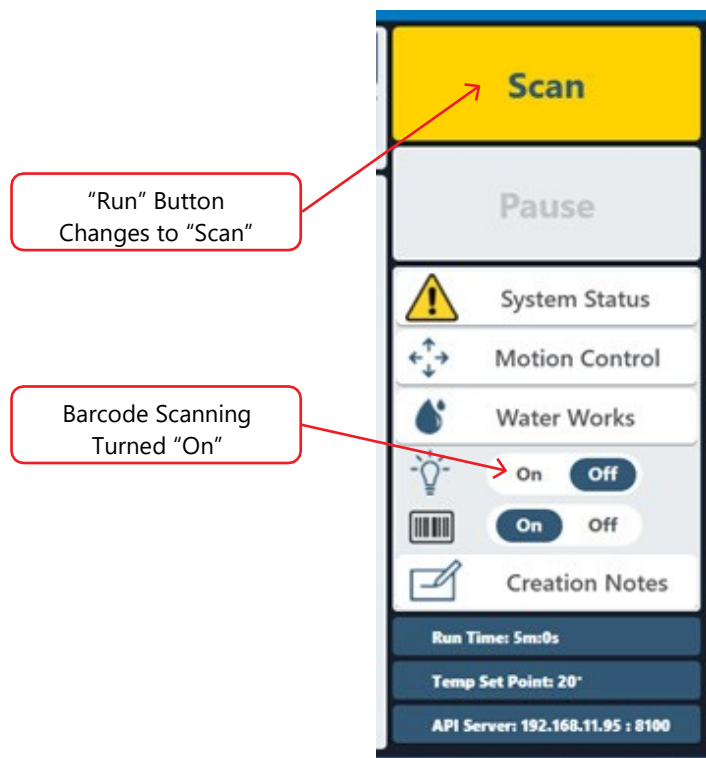

Click the "Scan" button, then click "Yes" when prompted to confirm scanning. The "Scan/Enter Barcode" box displays. Scan the barcode, or, optionally, enter a value or label using the computer keyboard.

Click "Next Position". If a plate is being treated, the "Scan/Enter" box closes and the "Scan" button changes to a green "Run" button.

If a rack is being treated, clicking the "Next Position" button provides an entry field for the next row to be treated. Enter its barcode and click "Next Position". Repeat until all rows to be treated have been scanned. After the last row has been scanned, the entry window closes, and the yellow "Scan" button becomes a green "Run" button, as described above.

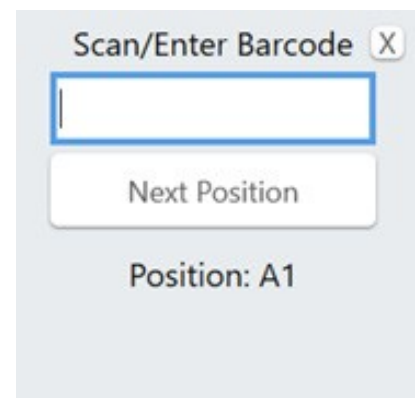

- **RFID:** Beginning in SonoLab version 8.4, RFID scanning is implemented. When a method employing the Covaris AFA-TUBE® is started, the sample tray is passed near an RFID reader mounted to the back of the water bath. An encrypted chip embedded in the AFA-TUBES's barcode label is read. The AFA-TUBE's serial number, date of manufacture, and proof of authenticity is stored in the LIMS folder. Methods employing the Covaris AFA-TUBE will not execute if the barcode label is not present.
- **Water Works Button:** Water Works allows the user to control the chiller and degas pump either manually or by automatic scheduling. For example, the schedule can be set to begin the degassing and chilling early in the morning so that your system will be ready to use when personnel arrive. Click on the "Water Works" button at the lower right of the Home screen to display the Water Works pane.

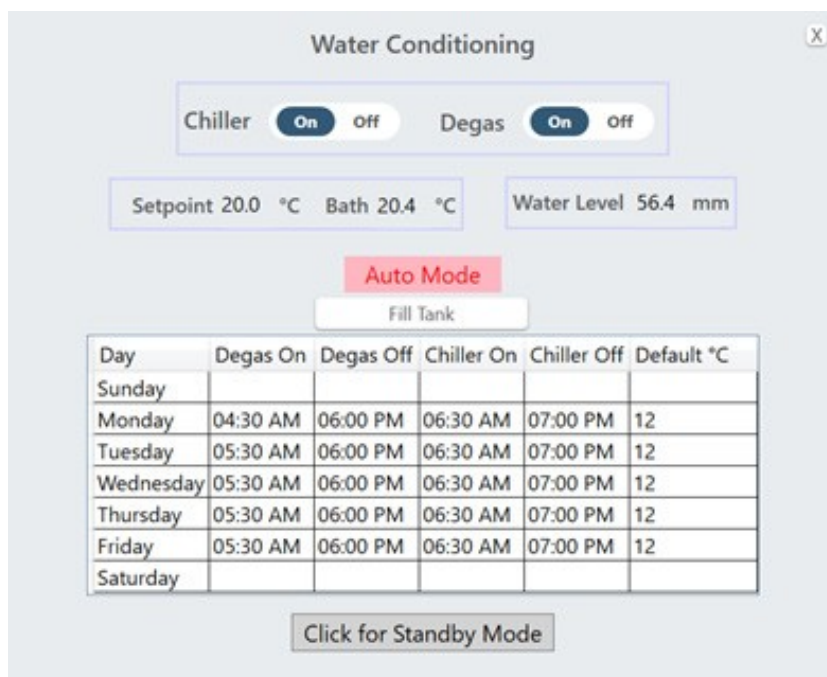

The Water Works pane contains the following:

- ON/OFF switches for chiller and degas pump: these are both switches and indicators. The current status is highlighted in blue, as shown above. These switches are disabled when operating in Auto (scheduled) Mode.
- Current chiller set point, current system bath temperature, and current system bath water level.
- Enable/disable switch for automatic temperature and degas pump control: this is both a switch and indicator. It toggles between Auto Mode, as shown above, and "Auto is Off" when automatic control is not active. In Auto Mode, the chiller, chiller temperature set point, and degas pump are controlled by the user defined schedule.
- Enable/disable Standby Mode button: this is both a switch and indicator. It toggles between "Click for Standby Mode" and Standby Mode. In Standby Mode, the chiller cooler/heater element is disabled, and the transducer is raised out of the water bath. Scheduled temperature control and degassing are disabled when the instrument is in Standby Mode.
- Fill Tank button (optional): if the AutoFill option for the instrument bath is enabled on the system, this button will be present in the Water Works pane. Clicking the button fills the bath. Depending on the amount of water added, a degassing delay will occur, during which methods cannot be run. The following table summarizes the degassing delay time.

Volume added	Degas time
< 1 liter	No wait time
1 to 2 liters	30 minutes
> 2 liters	45 minutes

- *Automatic Water Level Control (AutoFill)*: The AutoFill option consists of hardware to implement connection of plant deionized water to your system so that sufficient bath water is automatically maintained to allow instrument operation. Refer to the appendix of this manual for instructions on making connections to AutoFill. AutoFill is enabled by an entry in a configuration file. The water level is checked every 15 minutes when the instrument is idle, and before each method is run. If necessary, water should be added to the bath followed by a delay to allow degassing of the added water to be executed. Degassing time is determined according to the table below.

Volume added	Degas time
< 1 liter	No wait time
1 to 2 liters	30 minutes
> 2 liters	45 minutes

- *Automatic Chiller/Degas Operation*: An automatic schedule for degassing and chilling your system's water bath is a convenient way to have the instrument ready to use at the beginning of the day. Under software control, your system's water bath will automatically activate degassing and adjust to the user specified temperature at the beginning of the schedule period. It will also turn off the degas pump and place the chiller in standby mode at the end of the scheduled period. In standby mode, the chiller's heating/cooling circuit is disabled while the pump continues to operate, circulating bath water through the WCS filter. Refer to the ultraCUBE User Manual for details about the operation of the chiller and WCS.

NOTE: All accounts must be logged out of SonoLab for the automatic temperature control operation. At the time scheduled for cooling to turn on or off, any logged in user's method will override the automatic settings. The automatic settings will not then immediately take effect when this user logs out. The automatic settings will only take effect at the next scheduled change.

To configure a schedule, perform the following steps:

- Double click anywhere in table shown in the image above to display the *Automations Settings* window.
- Note:* To configure a schedule for just one specific day, Sunday through Monday, double-click on that day in the table.

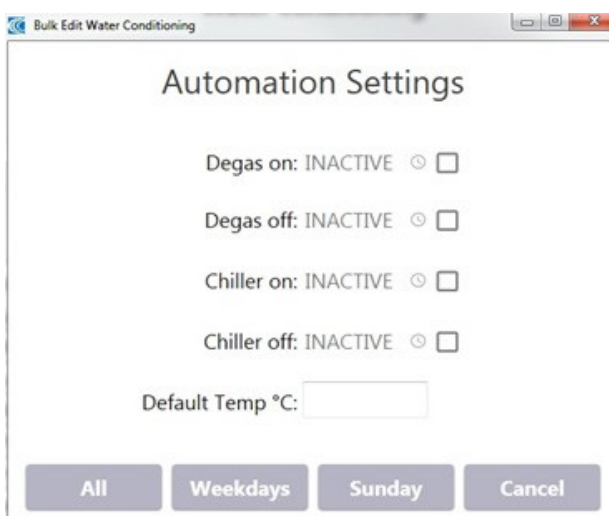

- Click in the check boxes for the functions to be scheduled. Normally, all four boxes will be checked.

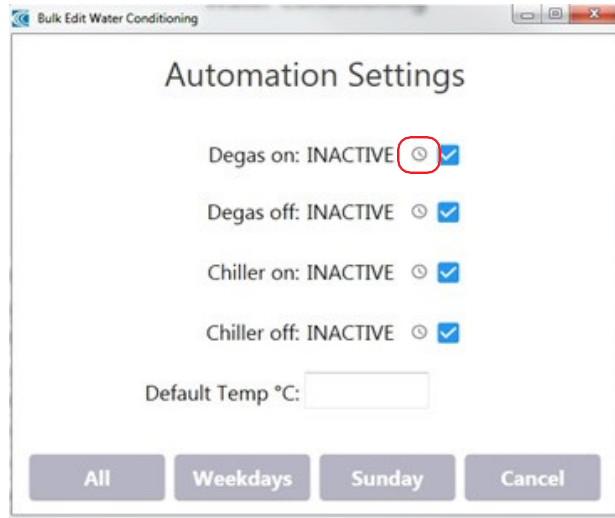

- Click on the clock icon for Degas on, circled above. This displays a clock.

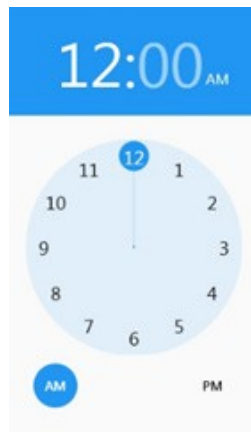

- Click on either AM or PM, then on the hour the degas pump is to start. The clock changes to display the hour selected (7 o'clock in this example) and the minutes part of the time highlighted.

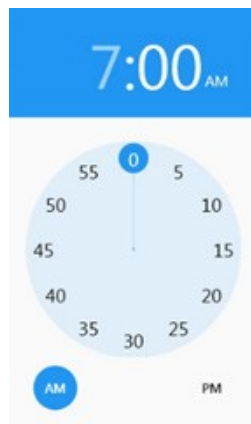

- Click on the number of minutes after the hour. The clock display closes, and the user is returned to the Automation Settings screen.
- Repeat the above steps for Degas off, Chiller on, and Chiller off.

Note: The scheduler forces the chiller start time to be at least 30 minutes after the degas start time. Cold bath water does not degas efficiently. The 30 minute delay permits the water to be sufficiently degassed before it is too cold. Once degassed, the system will maintain a sufficiently degassed condition regardless of water temperature.
- Enter the desired chiller set point, in whole degrees, in the Default Temp °C field.
- Click on either All, Weekdays, or the single day, in this example Sunday, button at the bottom of the Automation Settings screen. The Automation Settings screen closes and the Water Works pane is displayed.

Auto Is Off					
Day	Degas On	Degas Off	Chiller On	Chiller Off	Default °C
Sunday					
Monday	7:30 AM	4:00 PM	8:00 AM	4:00 PM	10
Tuesday	7:30 AM	4:00 PM	8:00 AM	4:00 PM	10
Wednesday	7:30 AM	4:00 PM	8:00 AM	4:00 PM	10
Thursday	7:30 AM	4:00 PM	8:00 AM	4:00 PM	10
Friday	7:30 AM	4:00 PM	8:00 AM	4:00 PM	10
Saturday					

In this example, the Weekdays button was clicked.

- Click Auto Is Off. The button changes to a red Auto Mode button, and chilling and degas will start and stop as scheduled on weekdays. In Auto Mode, the chiller and degas buttons at the top of the Water Works pane are disabled.

NOTE: All accounts must be logged out of SonoLab for the automatic temperature control operation. At the time scheduled for cooling to turn on or off, any logged in user's method will override the automatic settings. The automatic settings will not then immediately take effect when this user logs out. The automatic settings will only take effect at the next scheduled change.

- **Manual Chiller and Degas Control:** To manually control degassing and chiller operation, click the red Auto Mode button. The button will change to Auto Is Off, indicating that manual control is enabled.

In Manual Mode, the chiller and degas pump may be toggled on and off by clicking the buttons at the top of the window.

Clicking the "Click for Standby Mode" button places your system and ultraCUBE in standby. The transducer and sample tray move to the service position, the degas pump turns off, and the chiller heating/cooling unit turns off. The chiller pump will continue to operate, circulating the bath water through the WCS unit.

Note: If your system is left in Standby mode, i.e., the transducer is up and out of the water bath, automatically scheduled events will not occur.



• *Motion Control Button:*

- *Home:* Moves all motion axes to their initialized position, as occurs when the software starts.
- *Load Position:* Moves the tray to the front of the safety enclosure to facilitate loading samples.
- *Start Position:* Takes the sample tray to the treatment position of the first row of the currently selected method. This position may be used to verify that the water level in the bath is correct.
- *Service Position:* Raises the sample tray and the transducer assembly allowing the water bath to be removed from the instrument.
- *Stop:* Stops any motion currently in progress.

3.4 Running a Method

When the “Run” button is green, the selected method may be started. Click the “Run” button to start. The instrument will verify that water level is appropriate for the specified for the method, and begin the treatment.



Once a method starts, if the bath temperature rises beyond the user specified limit, your system finishes the acoustic treatment of the current row of the plate, then pauses, and automatically resumes treating the remaining rows when the temperature is within limits, with no operator intervention required.

As the method runs, the graphic for the row under treatment flashes green, and the actual average incident power and temperature data are displayed, as shown.

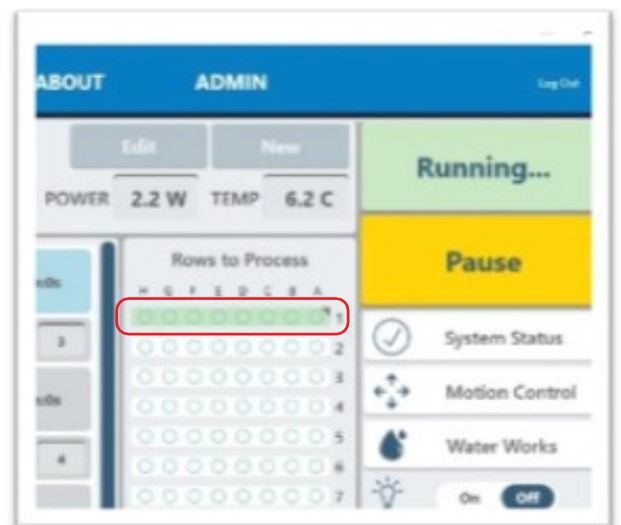

The user may, at any time while running a method, click “Pause” to interrupt a running method.



When the method is paused, the user may continue the method by clicking the *Resume* button or terminate the method by clicking the *Abort* button.



When the method has finished, the message “Method Complete” is displayed. Click “OK”, then press the green door lock button and open the safety enclosure door. Remove the treated sample plate.

For methods with high wattage (> 125 watts) and low bath temperature, it is recommended to allow 5 to 10 minutes between plates to allow bath to cool.

3.5 Daily System Shutdown

If the instrument will be idle for an extended period of time (e.g. longer than two weeks), refer to the system shutdown procedure in the User Maintenance section of this manual.

When your system is finished being used for the day, leave the transducer submerged in the bath if automatic scheduling is active.

At the end of the scheduled period, the scheduler will turn off the degas pump and disable cooling in the chiller, then automatically restart both as scheduled for the next day. SonoLab software must be left running and the system and ultraCUBE powered on for the scheduled events to occur.

If automatic scheduling is not in use, click on the ‘Water Works’ button and then the ‘Click for Standby’ button. The transducer will rise out of the bath and the ultraCUBE chiller’s heater/cooler will turn off, but the chiller’s pump will continue to operate, circulating bath water through the ultraCUBE water conditioning system.

Note: No scheduled events will occur when the instrument is in “Standby” mode, regardless of whether or not SonoLab is in “Automatic” (scheduled) mode.

CAUTION: Do not turn off either the WCS or CH05 chiller. These must remain powered on to treat the bath water against bio-growth. Leaving water in the water bath for an extended time without the WCS operating may promote algal growth in the tank and lines, this growth can interfere with water quality and sample processing.

4. Create and Edit Methods

The SonoLab Method Editor supports the creation of new methods and editing of existing ones.

A method consists of one or more Processes. A Process contains at least one Treatment. Most methods will contain a single process, containing a single treatment step.

If more complex methods are required, they can be easily constructed.

4.1 Create a New Method

To create a new method, click the “New” button on the main screen.



Figure 4.1 New Method Button on Main Screen

The Method Editor window will appear.

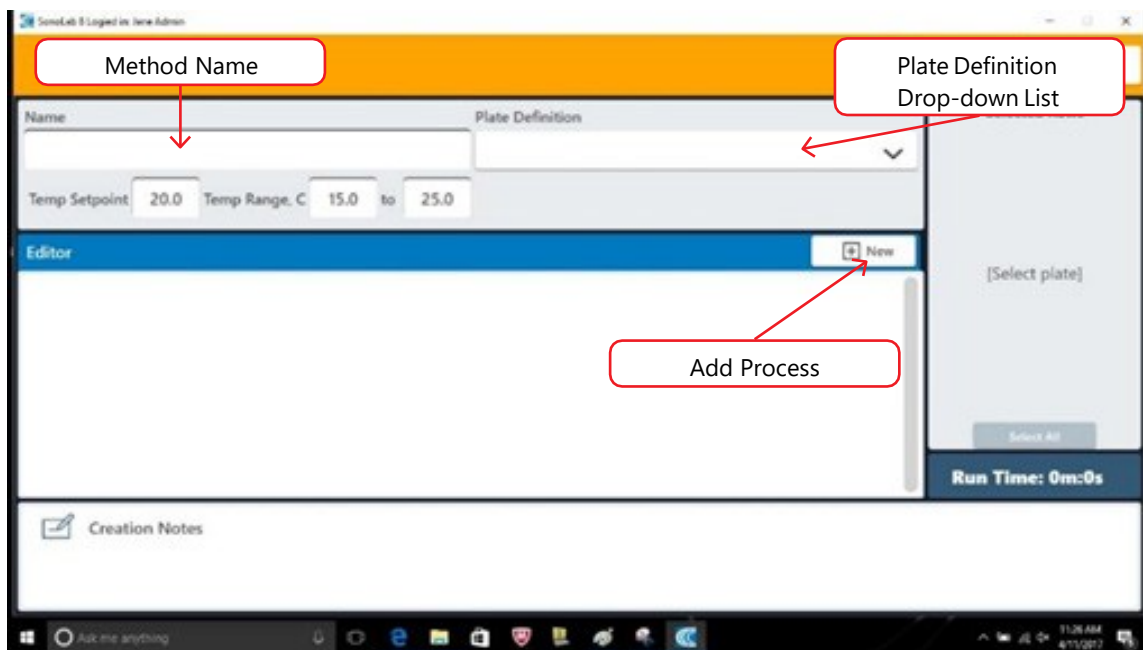
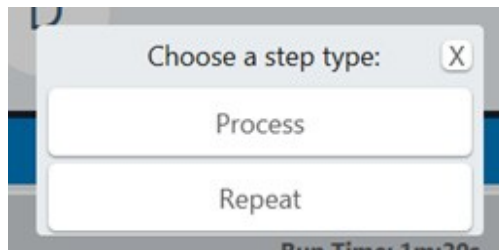

Figure 4.2 Method Editor Window

- 1) Enter the name of the new method in “Name” box as shown.
- 2) Select the appropriate plate for the consumables used in this method from the “Plate Definition” drop-down list.

4.1.1 Create or Add a Step in the Method

Click the + New button. The “Choose a Step Type” pop-up is displayed.



Click “Process”. The process bar is displayed. See section 4.2 below for a discussion of the Repeat function.

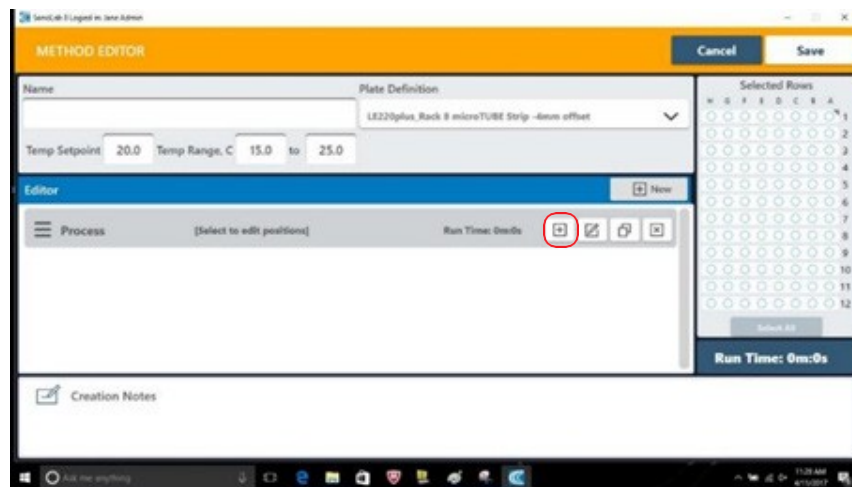

Click the + button inside the process bar to display the step type menu.

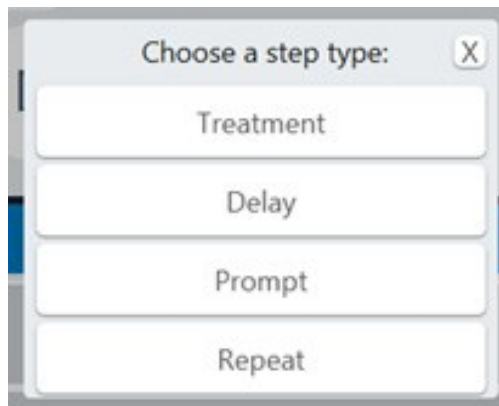

4.1.2 Choosing a Treatment

Choosing Treatment allows editing of the four acoustic parameters: Duration, Peak Incident Power, Duty Factor, and Cycles per Burst.

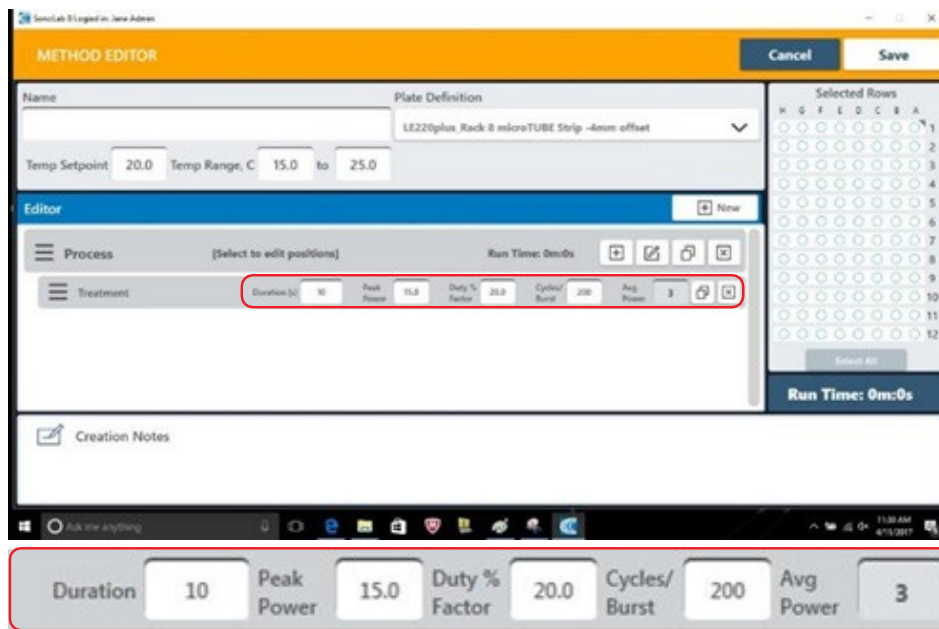

Figure 4.3 Add a Treatment

Add a Treatment: Treatment parameters are chosen by directly editing the Value box. The treatment parameters are:

- *Peak Incident Power (PIP)*: This parameter measures the peak electrical power used to drive the ultrasound transducer. In your system, the adjustable range of Peak Incident Power is 0.1 to 500 Watts.
- *Duty Factor*: This parameter defines the ratio between the on-time of the transducer and total operation time and is expressed as a percentage. For a given Peak Incident Power, a larger Duty Factor results in more acoustic energy generated from the transducer. Users can define the Duty Factor from 0.1% to 50%.

The product of the Peak Power and Duty Factor gives the approximate Average Incident Power (AIP) generated from transducer. For example, if Peak Incident Power is set to 10 Watts and Duty Factor is set to 15%, the Average Incident Power will be approximately 1.5 Watts. However, the real average incident power from the transducer may vary due to factors such as sample tube type, water level, and water temperature.

- *Cycles per Burst*: This parameter indicates the number of electrical signals used in each acoustic “burst” of the transducer. On your system, you may define Cycles per Burst (cycles/burst) from 50 to 1000 for different applications. Advanced users may use this parameter to fine tune their experiments.
- *Duration*: This parameter defines the amount of time for which the sample is under a treatment. The measurement of the Duration is in seconds. The maximum time for any treatment is 3600 seconds. Should a longer treatment be necessary, “Duplicate Steps” can be used to extend the treatment. SonoLab displays the Average Incident Power, calculated from the Peak Incident Power and Duty Factor, adjacent to the treatment parameters in the treatment step bar. In the LE220- plus, the maximum Average Incident Power is 250 Watts (500 watts Peak Incident Power and 50% Duty Factor).

- *Dithering*: The LE220 motion system provides dithering motion capability in the X axis (fore-&-aft), Y axis (left-to-right), and Z axis (up-and-down). If a treatment specifies dithering, click on the “Pen-&-Paper” icon on the right end of the Process bar to display the Dithering Parameters pane.



The image shows a dialog box titled "Dither Parameters". It contains five input fields with numerical values: X +/- (mm) is 0.0, Y +/- (mm) is 0.0, Z +/- (mm) is 0.0, Speed (mm/s) is 10.0, and Pause Duration (s) is 0.0. At the bottom, there are two buttons: "OK" and "Cancel".

Figure 4.4 Dither Parameter Pane

Enter the specified dithering parameters and click “OK”.

- *Temperature Set Point and Range*: Enter the temperature set point for the protocol and the allowable range into the text entry fields. SonoLab allows a minimum range of plus/minus 3 degrees.

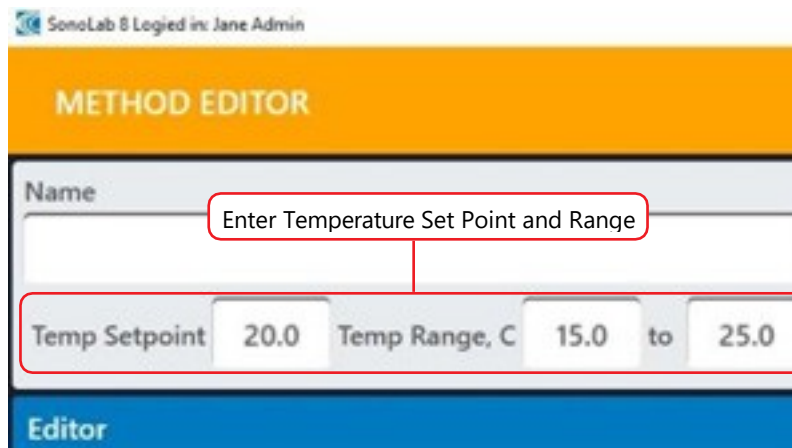

The image shows a screenshot of the "METHOD EDITOR" interface. At the top, it says "SonoLab 8 Logged in: Jane Admin". Below that is a yellow header with "METHOD EDITOR" in white text. Underneath is a "Name" field with a red box around it containing the text "Enter Temperature Set Point and Range". Below the name field is a row of input fields: "Temp Setpoint" with the value "20.0", "Temp Range, C" with the value "15.0", and "to" with the value "25.0". A red box highlights this entire row. At the bottom, there is a blue bar with the word "Editor" in white text.

Figure 4.5 Entering Temperature Set Point and Range from lower to upper limits

4.1.3 Entering Temperature Set Point and Range from Lower to Upper Limits

Once the treatment parameters have been defined, click in the process bar to highlight it, then click in the treatment well graphic to define which plate positions will be treated. Your system can treat an entire row at a time. Therefore, clicking anywhere in a row causes the row to be selected. Any number of rows may be selected for treatment; rows selected for treatment turn from white to yellow. Clicking on a row a second time removes it from the list to be treated. When the method is run, the graphic for the position being treated flashes green, indicating which position is under treatment.

Rows 1, 3, 6, and 9 Selected for Treatment

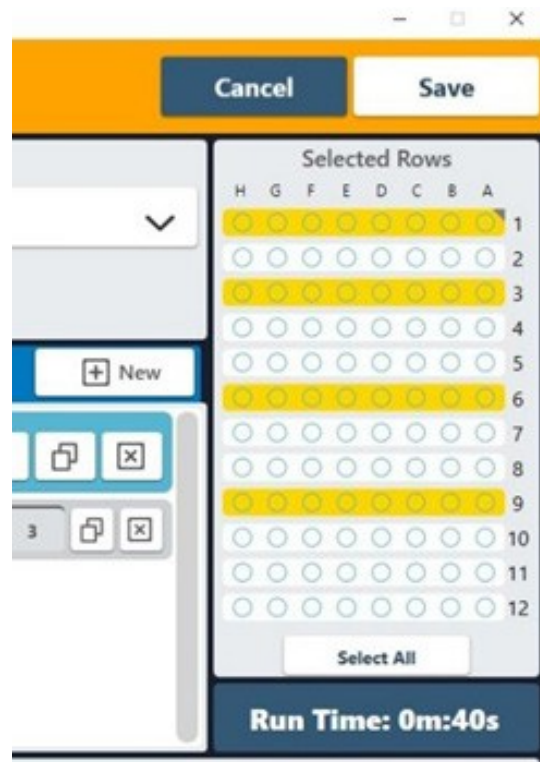

Figure 4.6 Rows 1, 3, 6, and 9 Selected for Treatment

4.1.4 Choosing a Delay Step

As an example, choosing a Delay step introduces a fixed time delay into a method which allows the sample to settle between two different treatment steps. The delay is specified in seconds.

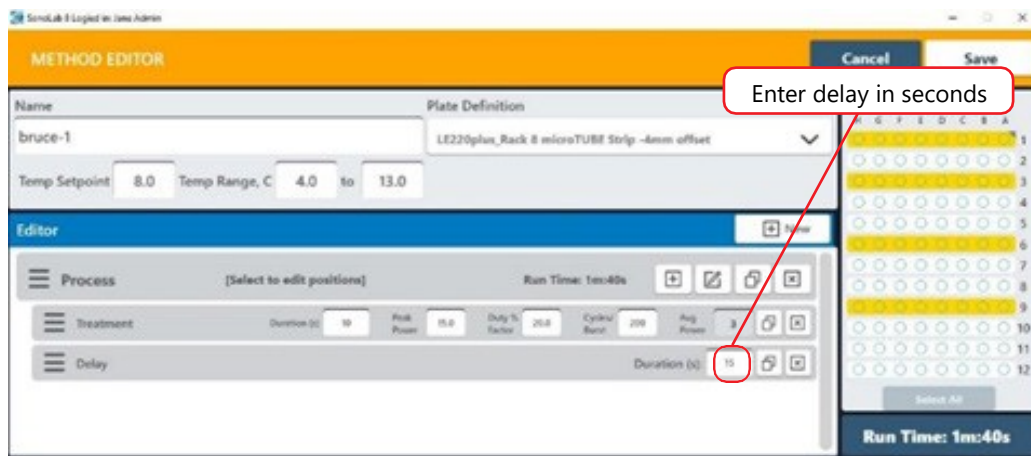

Figure 4.7 Add a Delay Step

4.1.5 Choosing a Prompt Step

Choosing a Prompt step displays a specified message on the screen and pauses execution of the method until the operator clicks OK. Define the prompt message by clicking on the “pen & paper” button of the prompt bar to display the text entry field for the prompt. Enter the text of the prompt and click OK.

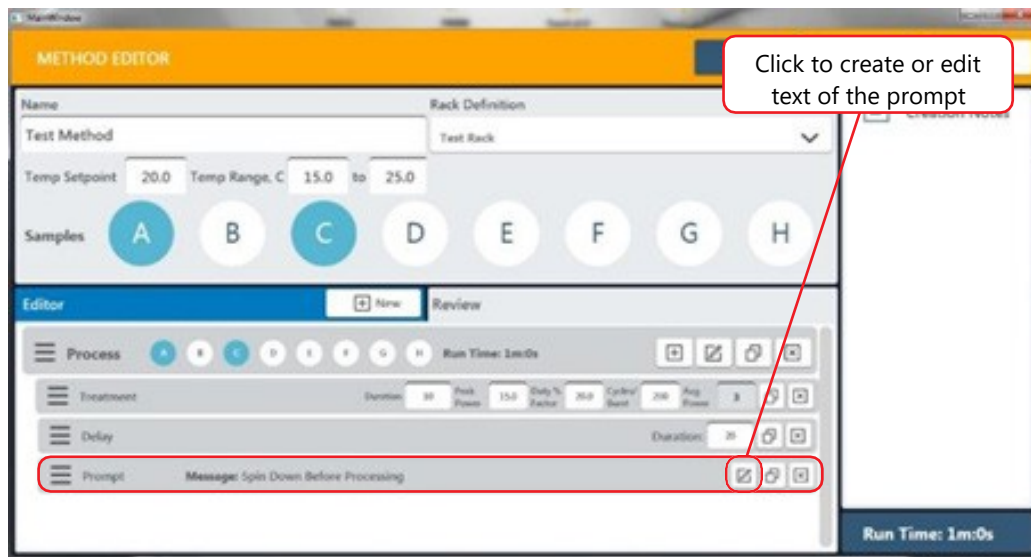

Figure 4.8 Add a Prompt Step

Add a Prompt Step: When the prompt step is reached during the treatment, the method pauses, and the prompt message will be displayed as shown in Figure 4.9.



Figure 4.9 Example of a Prompt Message Display

4.1.6 The “Creation Notes” section is a text entry box at the right side of the Method Editor screen in which the user may enter, for example, descriptive text relating to the method being created. This field may be left blank if the user so chooses.

4.1.7 When all method parameters and steps have been defined, save changes.

4.2 Creating Methods using Repeat Function

The Repeat function is used when one or more treatment, delay, or prompt steps are to be applied to each row of the plate multiple times. There are two scenarios for how this may need to be performed, and the required scenario determines how the repeat function is implemented.

In Scenario A, all treatment (delay or prompt) steps are applied to the first row, the number of times specified in the repeat bar, then all steps are applied to the next row. This continues until all rows in the plate are treated.

Scenario A is used if each row requires one or more acoustic doses, but there is no need for resting the sample between doses.

4.2.1 Implement Scenario A:

- Create a method with a Process step, as explained in section 4.1.1 above.

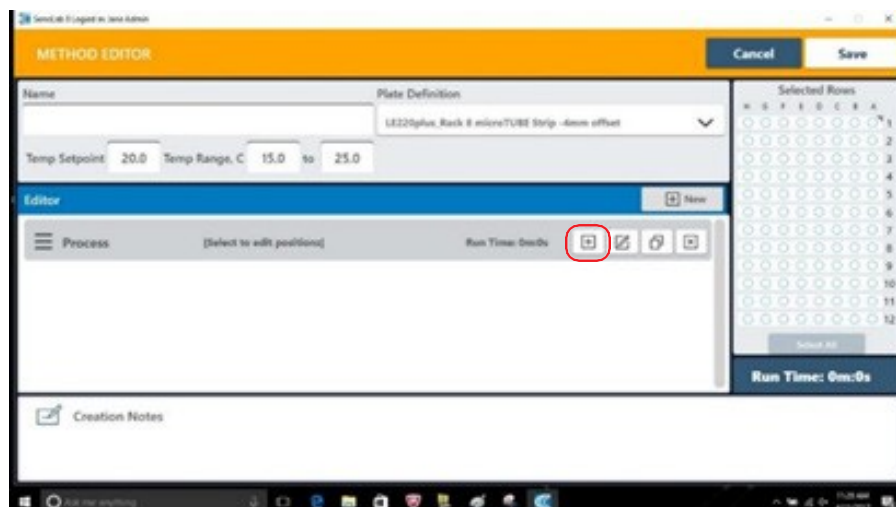

- Click the + button inside the process bar to display the step type menu.



- Click on *Repeat*.
- Click the + button inside the repeat bar to display the step type menu and create two or more treatment steps. See image below.

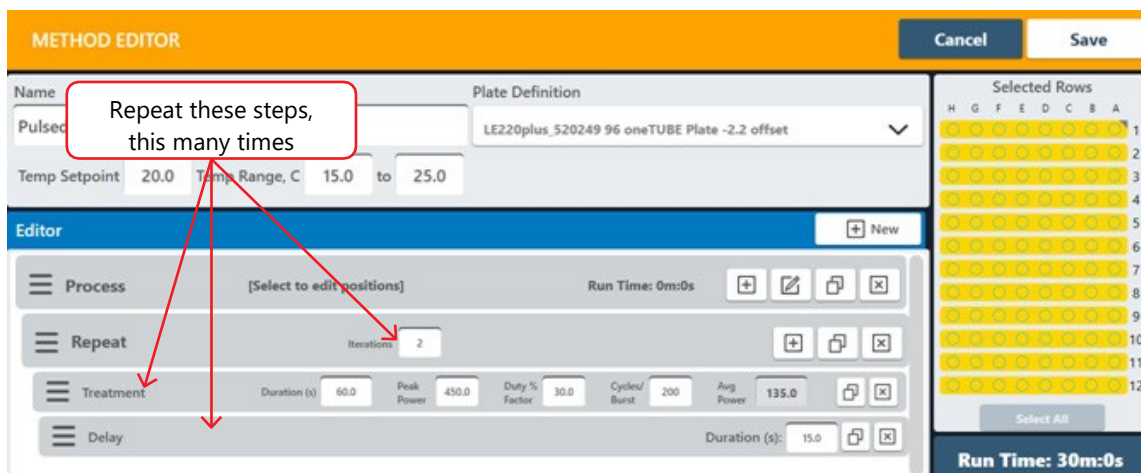

All listed treatment (or delay, etc.) steps will be applied to the first row selected for treatment, the number of times specified in the Repeat bar. Then all will be applied to the second row, and so forth, until the entire plate is treated.

- When all method parameters and steps have been defined, save changes.

In Scenario B, all treatment (or delay or prompt) steps are applied to all selected rows of the plate once. This repeats for the number of times specified in the Repeat bar.

Scenario B is typically used in “pulsing”. That is, a row is treated with an acoustic dose, and is then allowed to rest while the remaining rows are treated. Once the remaining rows are treated, a second acoustic dose is applied to each row.

4.2.2 Implement Scenario B:

- Create a method as explained in section 4.1.1 above but select “Repeat” instead of “Process” for the step type.

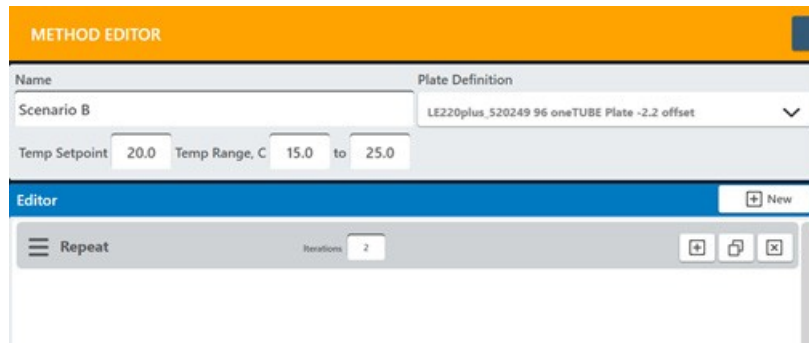

- Click the + button inside the Repeat bar and select Process.

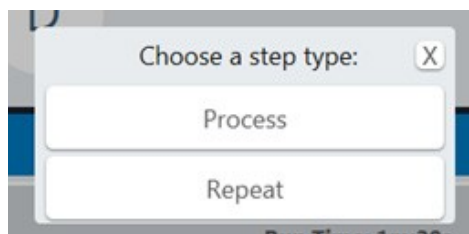

- Click the + button inside the Process bar and create one or more treatment steps. Two treatment steps are created in this example.



- All treatment steps will be applied to all selected rows of the plate once and then repeated for the number of times specified in the Repeat bar. That is, both programmed Treatments will be given to Row A, then both Treatments will be given to Row B, and so on until the entire plate is treated and then the treatment steps are repeated.
- When all method parameters and steps have been defined, save changes.

4.3 Scanning Treatments (LE220Rsc Only)

In a scanning treatment, rather than the sample tray indexing to place one column of the sample tray at a time over the transducer, the sample tray moves continuously from under the sample tray. In this mode, treatment time is a function of the speed at which the sample tray moves. One or more rows may be treated, but the rows must be adjacent.

4.3.1 Create a scanning treatment:

- Click the “*add process*” button.

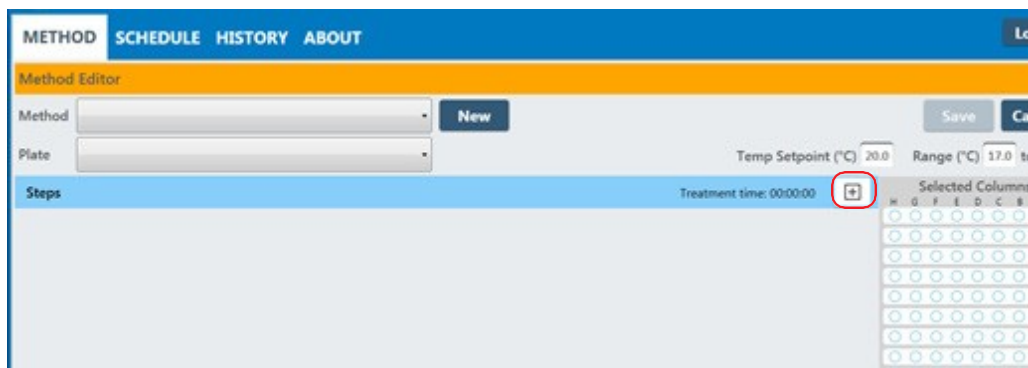

- Select *Repeat* from the step type list.

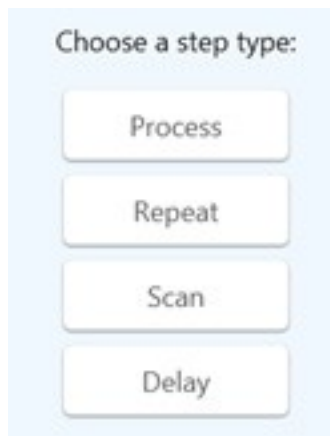

- Enter the desired number of scans. One scan passes the sample tray over the transducer one time.
- Click the “*add process*” button again.
- Select *Scan* from the Step Type list.
- Enter the desired treatment parameters as for a normal treatment step.

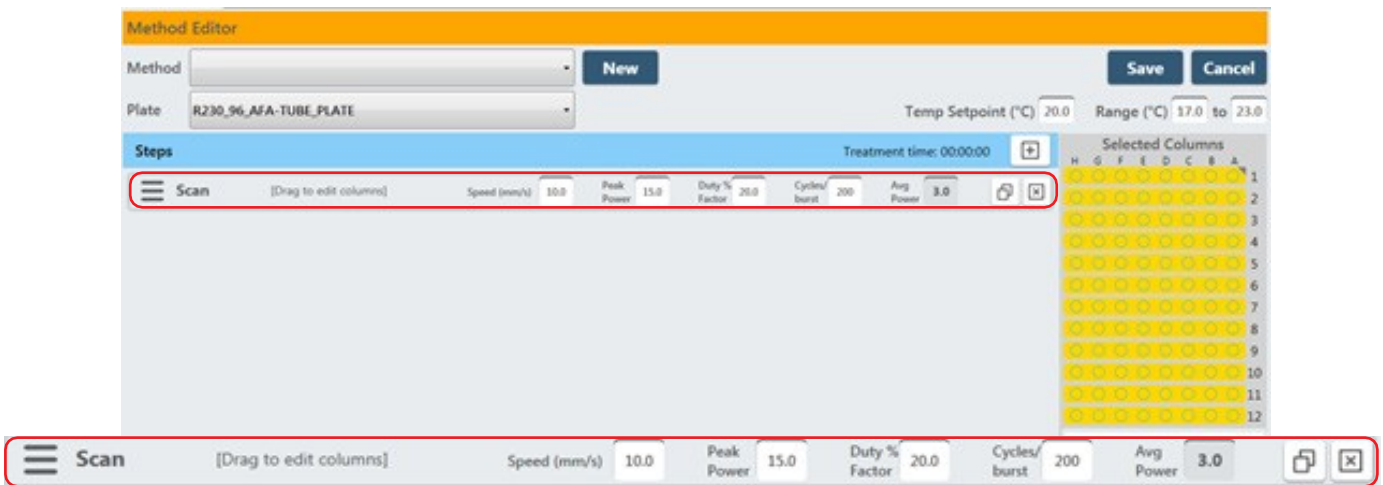

Figure 4.10 Selecting a Method to Edit

- Click *Save* and give the method a name as with normal treatment methods.

Contact our Covaris Applications Support Department for assistance in specifying the appropriate scanning speed and treatment parameters for your application.

4.4 Modifying Existing Methods

To modify an existing method, select the method as described above, then click the “*Edit*” button. The method editor window will be displayed. Make desired changes and click ‘*Save*’. The user is then prompted to confirm if they wish to overwrite the existing method.

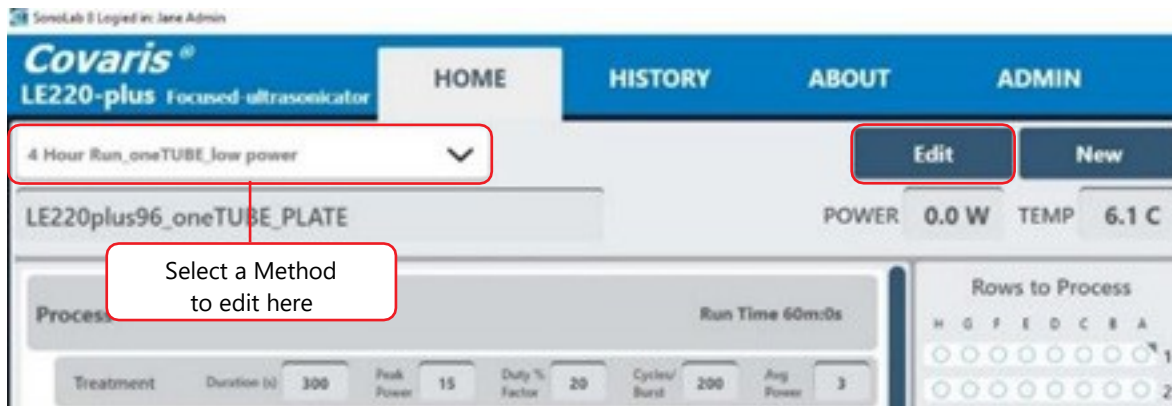

Figure 4.10 Selecting a Method to Edit

5. SonoLab Application Software

The main components of SonoLab software include:

- *Home* – Compose or select methods to run
- *History* – View system usage history
- *Admin* – Add and configure SonoLab user accounts (only available to admin users)
- *About* – Information on system configuration

5.1 Home Screen

The Home Screen is the principal user screen for the system. Refer to Section 3.3 for details on operating the instrument through the Home Screen.



5.2 History Tab

The History tab (Figure 5.1) provides a scrolling list containing the history of every method performed on the instrument. This list can be sorted by method name, date the method was run, the operator who ran the method, or the run status (complete, aborted, failed).

Method	Run Date	Run By	Status
4 Hour Run_aveTUBE_low power	4/11/2017 10:41:12 AM		Method Aborted
4 Hour Run_aveTUBE_low power	4/11/2017 10:43:30 AM		Method Aborted
4 Hour Run_aveTUBE_low power	4/11/2017 10:43:25 AM		Method Aborted
4 Hour Run_aveTUBE_low power	4/11/2017 10:25:36 AM		Method Aborted
LE220-plus_GClean_200bp_90 ColonyCap_wTUBE	4/11/2017 10:25:36 AM		Method Aborted
LE220-plus_GClean_200bp_90 ColonyCap_wTUBE	4/5/2017 8:23:59 PM		Method Completed
LE220-plus_GClean_200bp_90 ColonyCap_wTUBE	4/5/2017 5:28:09 PM		Method Completed
LE220-plus_GClean_200bp_90 ColonyCap_wTUBE	4/5/2017 5:12:09 PM		Method Completed
LE220-plus_GClean_200bp_90 ColonyCap_wTUBE	4/5/2017 5:10:49 AM		Method Completed
LE220-plus_GClean_200bp_90 ColonyCap_wTUBE	4/5/2017 3:44:48 AM		Method Aborted
4 Hour Run_aveTUBE_low power	4/5/2017 4:15:45 PM		Method Completed
LE220-plus_GClean_200bp_90 ColonyCap_wTUBE	4/5/2017 3:58:37 PM		Method Completed
LE220-plus_GClean_200bp_90 ColonyCap_wTUBE	4/5/2017 3:24:01 PM		Method Completed
LE220-plus_GClean_200bp_90 ColonyCap_wTUBE	4/5/2017 3:27:07 PM		Method Aborted
4 Hour Run_aveTUBE_low power	4/5/2017 3:58:27 AM		Method Aborted
4 Hour Run_aveTUBE_low power	4/5/2017 3:47:51 AM		Method Aborted
4 Hour Run_aveTUBE_low power	4/5/2017 4:15:38 PM		Method Failed
Dan V_aveTUBE_avek Height Check	4/4/2017 4:14:52 PM		Method Completed
Dan V_aveTUBE_avek Height Check	4/4/2017 4:11:22 PM		Method Aborted
Dan V_aveTUBE_avek Height Check	4/4/2017 4:08:53 PM		Method Aborted
Dan V_aveTUBE_avek Height Check	4/5/2017 3:05:33 PM		Method Aborted

Figure 5.1 The History Tab

Double-click on a line to display its details. The left side of the screen will display textual information about the method. A pane on the right side contains graphs of the temperature and power levels generated for each sample treated by the method. This pane scrolls as necessary to display the graphs of all samples treated by the method. See Figure 5.2.

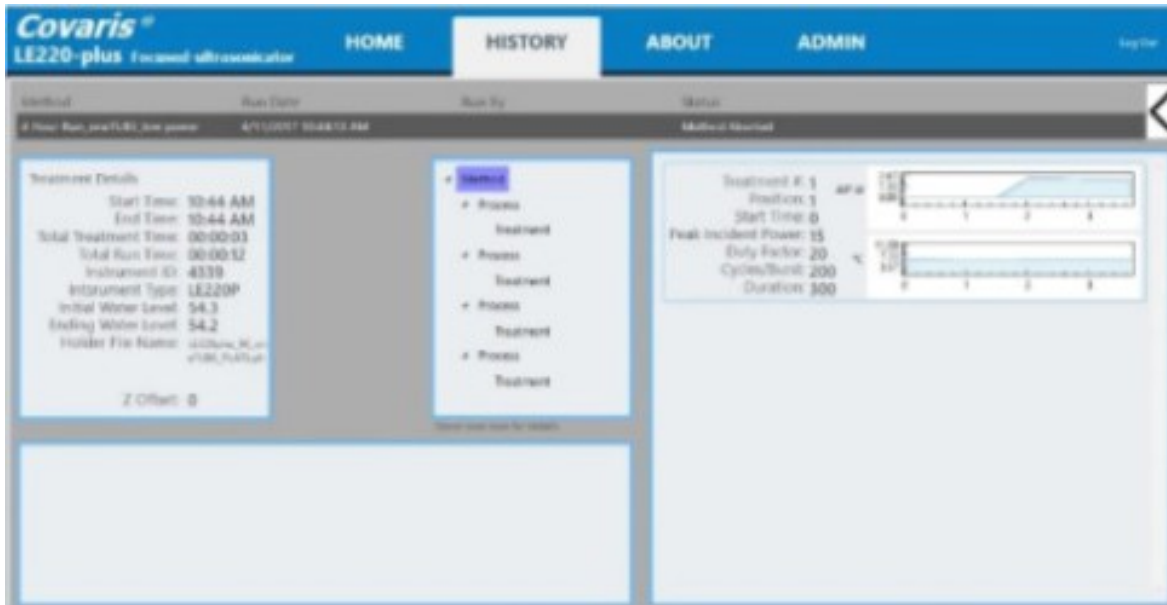

Figure 5.2 Details of a Method History

Double-click on one of the graphics on the right side. The graphic will be outlined in orange indicating it has been selected. Additional information pertaining to the part of the method which generated the specific graphic is displayed on the lower left. See Figure 5.3.



Figure 5.3 Additional History Details

Note: Occasionally, a history file may be corrupted. If this occurs, clicking on the “History” tab will result in an error message similar to Figure 5.4:

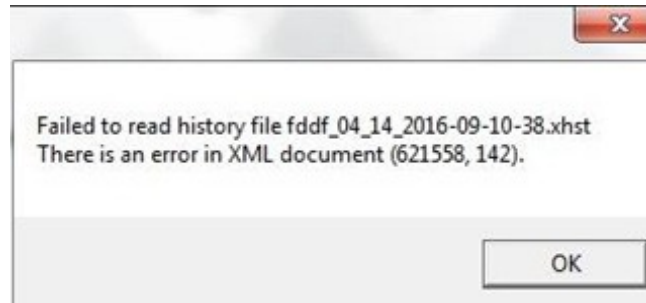

Figure 5.4 Message Indicating a Problematic History File

If this occurs, click the “OK” button to continue to the “History” screen. However, the error will be presented each time the “History” tab is selected, until the offending file is removed.

To remove the corrupt file, navigate to Documents\Covaris\SonoLab\History, then locate the offending file, in this example, “fddf_04_14_2016-09-10-38.xhst”. Drag this file to the Recycle Bin.

5.3 About Tab

The About Tab provides basic information about the instrument such as serial number, software version, board serial numbers, etc.

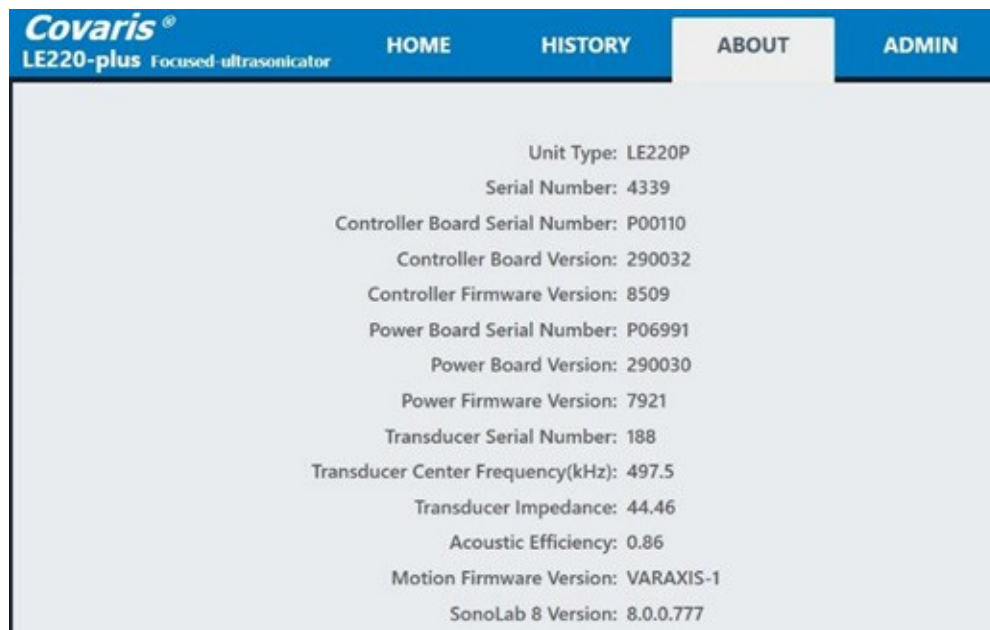

Figure 5.5 About Tab

5.4 Admin Tab

User Authentication: The User Authentication feature allows only authorized operators to log onto the system. User Authentication defines two levels of operators, Administrators and Users.

Permission Levels

An Administrator:

- Can add or edit other Administrator level users.
- Can add or edit user level users.
- Can assign access to specific methods to administrators and users.
- Can run and edit any methods installed on the system.

An Editor:

- Can run and edit methods assigned to them by an administrator.
- Can create methods.
- Can edit and run methods the user created.
- Can review the history screens for methods run by this editor.

An Operator:

- Can run methods assigned to them by an administrator.
- Can review the history screens for methods run by this operator.

Managing Users

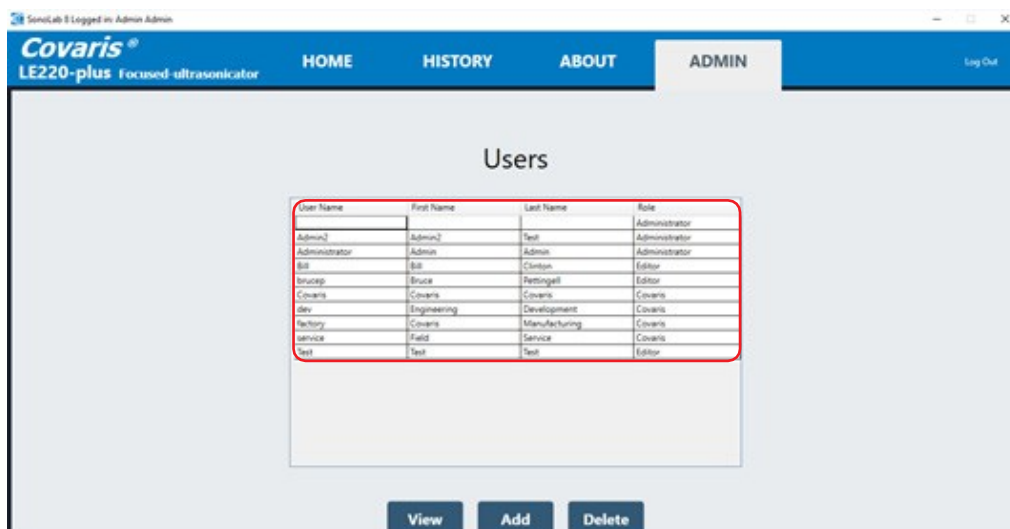

User Name	First Name	Last Name	Role
			Administrator
Admin2	Admin2	Test	Administrator
Administrator	Admin	Admin	Administrator
Bill	Bill	Clinton	Editor
brucep	Bruce	Pettingell	Editor
Covaris	Covaris	Covaris	Covaris
dev	Engineering	Development	Covaris
factory	Covaris	Manufacturing	Covaris
service	Field	Service	Covaris
Test	Test	Test	Editor

Figure 5.6 Admin Tab

5.4.1 Click to select a user. Then click the 'View' button to display a user's details.

A dialog box with the user's 'User Name', first name, last name, and 'Role' (Administrator or User) is displayed above a scrolling list of methods assigned to the user.



Figure 5.7 View User Screen

5.4.2 Clicking on 'Edit' produces 'Edit User' window.

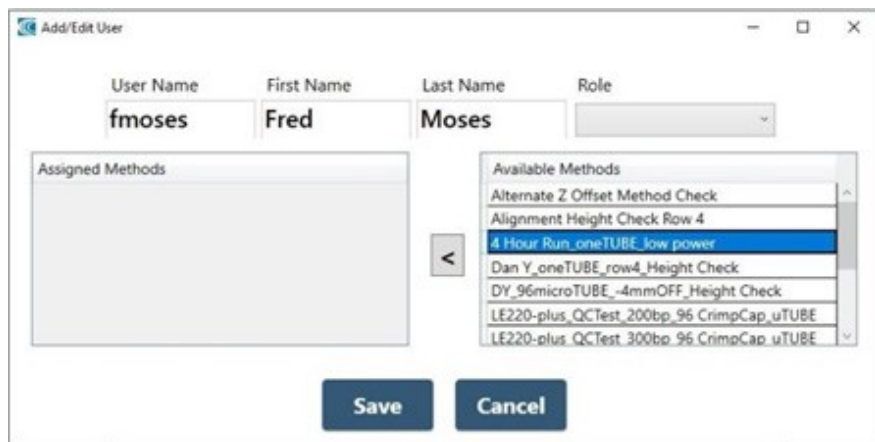

Figure 5.8 Edit User Screen

From this window, the user's name and role may be edited and methods may be added or removed from the methods available for the user to use. When a method in the list on the right is selected, the button between the available methods becomes a left pointing arrow, indicating the selected method will be copied to the 'Assigned Methods' list. If a method is selected in the 'Assigned Methods' list, the arrow points to the right, indicating the method will be deleted from the user's method list.

A user can only run methods in their "Assigned Methods" list, or methods they create.

5.4.3 Click the 'Save' button to save changes, the 'Cancel' button to exit without changes.

5.4.4 Selecting a user and clicking the 'Delete' button presents a confirmation dialog box. Click 'Yes' to confirm that you are deleting the user; click 'No' to exit without deleting the user. Once a user is deleted, the user cannot be reactivated, nor can that username be reused.

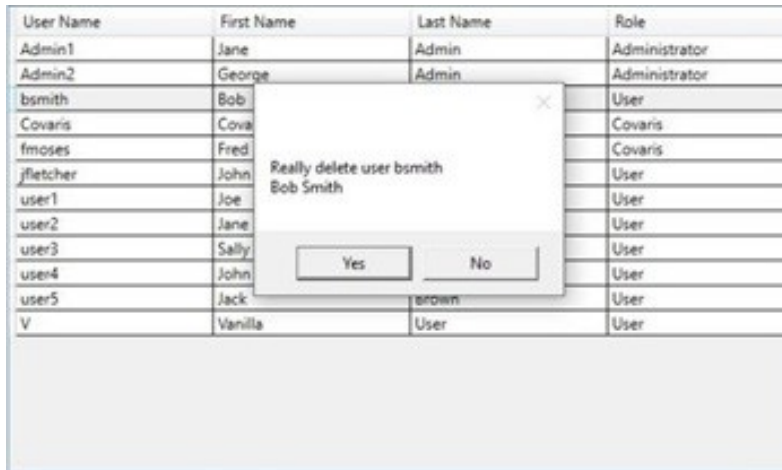

Figure 5.9 Deleting a User

5.4.5 Clicking the 'Add' button displays the 'Add/Edit User' window.



Figure 5.10 Add User Screen

- Select the Role from the drop-down list.

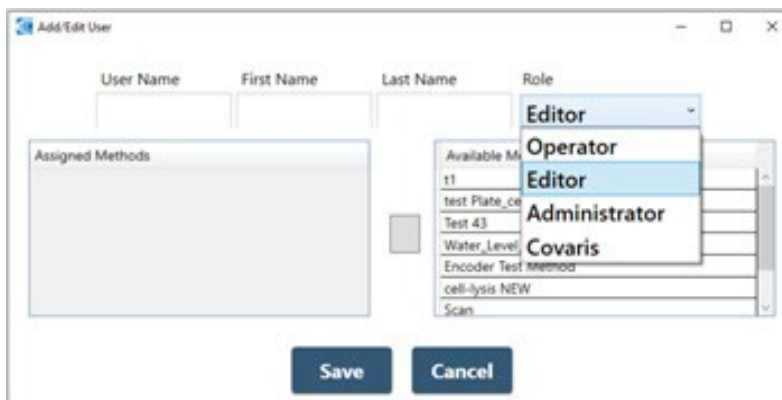

Figure 5.11 Select User's Role

- Fill in the User, First, and Last Name fields, and select methods to be assigned to the new user.

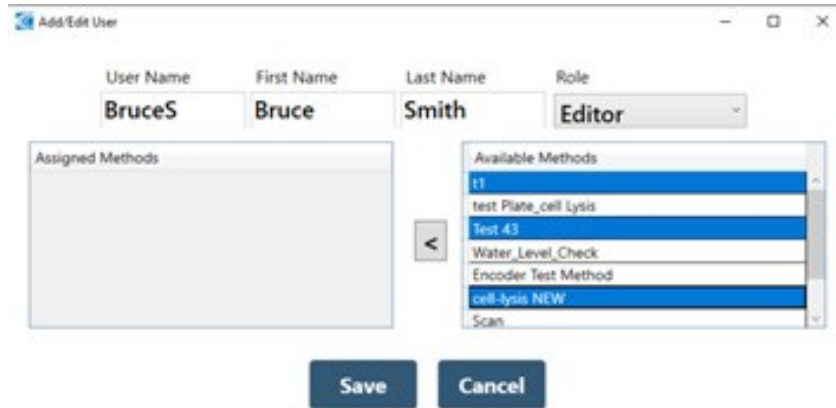

Figure 5.12 User ID and Method Selection

- Click the left-pointing arrow to add the methods to the user’s assigned method list.

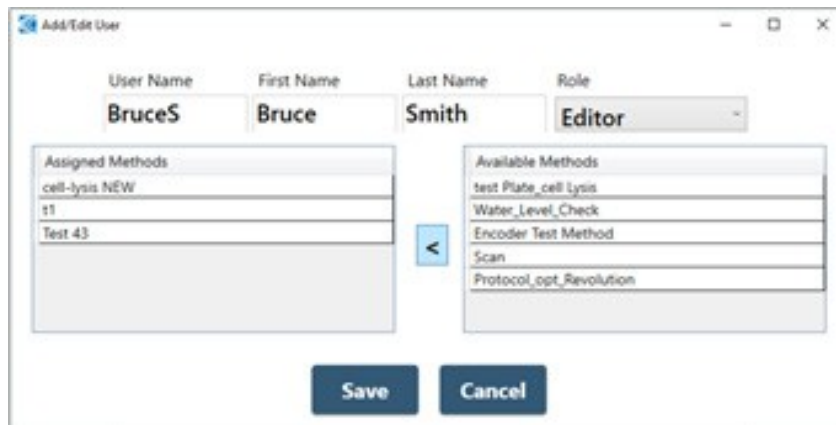

Figure 5.13 Methods Assigned to User

- Click ‘Save’ to add the user to the data base.

When a new user is created, the user will be prompted to create a password the first time the user tries to log in.



The user enters their new password, and then must enter it again to verify correct spelling. Clicking “OK” returns the user to the login screen, where the user may now enter the new password and log in.

6. System Specifications

Treatment System	Bench-top; high intensity acoustic transducer, temperature monitoring device, circulation pump, water bath with safety enclosure
Treatment Power	500 Watts Peak Incident Power, 250 Watts Average Power
Dimensions	23" W x 30" D x 19" H (59 cm x 76 cm x 48 cm)
Weight	Approximately 110 lbs. (50 kg)
Power Requirements	100-240 VAC 500 VA maximum, 50-60Hz
Ambient Temperature Range	19 to 25°C (66 to 77°F)
Ambient Humidity Range	30 to 70%
Regulatory Labeling	CE, ETL Mark (for Product Safety), WEEE
Safety	Complies with Low Voltage Directive 2006/95/EC. Certified to IEC/EN/ANSI/UL 61010-1:2004 and CAN/CSA C22.2 No. 61010-1:2004, 2nd Edition "Safety Requirements for Electrical Equipment for Measurement, Control and Laboratory Use, Part 1: General Requirements"
EMC	Complies with Class A Industrial/Scientific/Medical (ISM) equipment under EN 61326-1:2005, EN 61000-3-2:2004 and EN 61000-3-3:1995 for EU EMC Directive 2004/108/EC. Also FCC Part 15 Class A radio emissions requirements for the USA and ICES-003 Class A for Industry Canada.
Water Bath	Distilled or deionized water only
Temperature Alarms	Can be programmed from +0.5 °C to +55.0 °C
Computer	Notebook computer
Operating System	Microsoft Windows 10
Application Software	Covaris SonoLab
Data Input	Keyboard, mouse

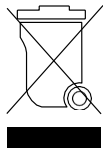

7. Maintenance

7.1 Cooling Air Intake

Periodically, unplug the unit and remove any obstruction to the fans and air vents on the rear panel to ensure that objects are not restricting the flow of air.

7.2 Water Bath

Periodically, unplug the unit and remove any obstruction to the fans and air vents on the rear panel to ensure that objects are not restricting the flow of air.

7.2.1 Recommendations for Daily Maintenance

Only distilled or deionized water should be used to fill the water bath. To avoid algae growth, the water bath should be emptied, the degas lines purged, and the tank dried prior to longer term (more than a week) idle time. See 'Shutdown for Long Term Storage' below.

7.2.2 Recommendations for Monthly Maintenance

Periodically, the water bath and degassing lines should be rinsed with a 10% solution of bleach (or equivalent, such as NaDCC).

The resultant sodium hypochlorite solution is ~ 0.5% NaOCl. Perform the following cleaning protocol:

- 1) Turn off the WCS and CH05 chiller and disconnect the hoses from the front of the water tank.
- 2) Start SonoLab and open the 'Motion Control' pane.
- 3) Fill the tank with approximately 450 ml of household bleach or equivalent and the rest with DI water.
- 4) Click the 'Home' button. The transducer will lower into the bath and the degas pump starts.
- 5) Operate the degas pump for approximately 5 minutes.
- 6) Click the 'Service' button. The transducer rises out of the bath and the degas pump stops.
- 7) Empty the bleach/water solution.
- 8) Place the empty water tank back into the instrument and click the 'Home' button. The transducer lowers into the bath and the degas pump comes on purging the degas lines.
- 9) Click 'Service'. The transducer rises out of the bath.
- 10) Empty the tank, rinse, and fill with fresh DI water.
- 11) Place the water tank back into the LE220.
- 12) Click 'Home'. The transducer lowers into the bath and the degas pump starts. Allow pump to operate for 3 or 4 minutes.
- 13) Click 'Service' to raise transducer out of bath and turn off pump.
- 14) Repeat steps 10 through 12 twice more.
- 15) Fill the tank with clean DI water, reconnect and power on the WCS and CH05 chiller. Allow the water to degas for an hour prior to treating samples.

7.3 Transducer

Use care when handling the transducer. Permanent damage could result if anything is dropped onto the face of the transducer or if the face of the transducer is damaged.

If drying or cleaning the transducer face, use a soft lint-free cloth. If broken glass must be removed from the transducer surface, carefully pick any shards off the surface with tweezers. Do not rub them away, as this may scratch the transducer surface.

7.4 Safety System

Test the system periodically. Verify that the acoustic treatments are disabled when the 'Stop' button is pressed, or if the water level in the tank is too low. Verify that the door cannot be opened during an acoustic treatment.

WARNING: Any failure of the Safety System must be reported immediately to Covaris. DO NOT attempt operation if the Safety System is malfunctioning.

7.5 Degassing System

Do not run the degassing pump without a water bath. Extended running without water will cause the pump head to wear out. If water is low, the pump will shut off within 10 seconds.

When the pump is running, verify that there are small bubbles coming from the end of the outlet nozzle. If you suspect that the system has become clogged, please contact Covaris for assistance. There is a small inlet tube that can be removed and cleaned.

Degassing the instrument is best performed on room temperature water, as water below 15 degrees C will not degas as efficiently. SonoLab prevents the chiller from coming on until the bath has been degassing for 30 minutes. If being operated manually, the operator should, likewise, begin degassing approximately 30 minutes prior to powering on the chiller. If it is necessary to have the instrument available first thing in the morning, use SonoLab's built in chiller and degas scheduler in the Water Works section.

For long-term storage, water should be removed from the degassing pump lines. Follow the System Shutdown procedure in Section 3.

7.6 Cleaning the System

Clean the external surfaces of the equipment as necessary with a damp lint-free cloth. Rinse the water tank with clean water and wipe dry with a lint-free cloth.

CAUTION: Any failure of the Safety System must be reported immediately to Covaris. DO NOT attempt operation if the Safety System is malfunctioning.

7.7 Water Bath

For Long Term Storage (more than 2 weeks)

7.7.1 Empty the water tank and purge the degaspump

- Turn off the WCS and the CH05 Chiller.
- Click on the Motion button to display the Motion Pane.

- Click on 'Service'. The degas pump will turn off and the transducer assembly will rise out of the bath.
- Empty the water bath and place it back in the instrument empty.
- Click 'Home'. The transducer will lower into the bath and the degas pump will come on, purging the lines to the degas pump.
- Click 'Service' when no additional water is coming from the lines, or when the pump shuts off. The transducer will raise out of the bath.
- Turn on the CH05 chiller, leaving it in stand-by mode. Allow it to run until no more water is pumped into the bath from the WCS.
- Empty the bath.
- Rinse it with clean DI water and dry it with a soft, lint free cloth.

If instrument is being placed in indefinite storage, remove the particulate filter from the WCS. Refer to instructions in the WCS manual as necessary.

Note: Since the particulate filter will remain wet internally even after draining, over a period of a couple weeks or more, some biological growth may take place, potentially leading to filter blockage and reducing filter life.

7.7.2 Close SonoLab

Exit SonoLab by clicking on the X in the upper right corner. The following message is displayed.



Click "No" to cancel this request or take no action and SonoLab will close following a 20 second countdown. Click "Yes" to close the application immediately. A message asking if the transducer should be moved to the Service Position is displayed. Clicking "Yes" causes the transducer to be raised out of the water bath; clicking, "No" leaves the transducer where it is, followed by the SonoLab software closing.

7.7.3 Turn System OFF

To shut down the laptop, select Shutdown from the START menu on the Windows screen and select the option SHUTDOWN. Then the computer will power down. Power down the instrument using the switch located near the power entry module of the instrument, at the rear of the right side.

CAUTION: Leaving water in the water bath or degassing lines for an extended time may promote algal growth in the tank and lines, this growth can interfere with water quality and sample processing.

8. Troubleshooting

This section provides a list of symptoms and recommended actions that may be taken to correct simple problems. Please contact the Covaris Technical Support Dept. or your local representative for assistance with any issues.

- If your instrument will not connect to SonoLab:
 - Verify that the instrument is ON.
 - Verify that the USB cable is connected at both ends and undamaged.
 - Close and restart the SonoLab application.
 - Go to Windows Device Manager (right click on Computer, then Properties) and verify that Windows is recognizing the instrument, and that device drivers are properly installed. Under Ports (COM & LPT), there should be four devices listed:
 - Covaris RF Controller (COM3)
 - Covaris RF Controller (COM4)
 - Covaris RF Controller (Port3&4) (COM5)
 - Covaris RF Controller (Port3&4) (COM6)

The COM assignments may be different from those listed above (e.g. COM 7, 8, 9, 10). Under Universal Serial Bus Controllers, there should also be four devices listed:

- Covaris RF Controller Board
- Covaris RS-485 Port
- Covaris Serial Port 2
- Covaris Serial Port 3

Each of these devices should be listed. If any appear with a yellow “!” symbol, right-click and try to re-install the device driver.

- Safety Interlock or Sensor Failures (Water Level, Water Tank Present, Door Closed, Water Temperature). These are generally failures that require the attention of a Service technician, but please verify the following items before contacting Service:
 - Water Level: Verify that the water level in the tank is at or above the “0” mark on the WATER LEVEL label. Verify that the Acoustic Assembly is fully lowered into the tank.
 - Tank Present: Verify that the Acoustic Assembly is fully lowered into the tank. Verify that the tank is slid fully into the enclosure, so that the magnet embedded at the rear of the tank can be sensed. Verify that the magnet is embedded in the rear of the tank.
 - Door Closure not recognized: Verify that the door interlock is not bypassed.
 - Water Temperature limits being reached, or inaccurate temperature readings: If the water is running hot, verify that the chiller is operating and that it is circulating water through your system’s water bath. Program the set point of the chiller to a lower temperature (select a method with a lower set point specified) and verify that your system’s bath gets cool. Use a separate thermometer to verify the true temperature of the bath.
- Biological or chemical results (e.g. DNA shearing) not as expected:
 - Verify that the average power values reported by SonoLab are approximately correct. The typical average power is a few percent below the value “Peak Incident Power” multiplied by “Duty Factor”. For example, if PIP=200 Watts and Duty Factor is 10%, then an expected power reading would be approximately 15 to 17 Watts.
 - Verify that the water temperature is correct and that the water is clear and free of algae or other particulates. Perform a protocol cleaning protocol with a 10% bleach or equivalent solution if this has not recently been done.
 - Verify that the degassing pump is operating (observe the pump outlet on the left side of the tank – when the pump is running there should be occasional bubbles exiting the pump outlet tube). Also examine the inlet “dip tube” visible from the right side of the tank. The inlet holes (very small drilled holes in the side of the tube) should be free of obstruction.

- If possible, please independently verify your analysis equipment. Covaris has DNA shearing verification kits available. Please contact Covaris applications support or your local representative for assistance.
- SonoLab reported Power Level is lower or higher than expected:
 - Verify that the average power values reported by SonoLab are approximately correct. The typical average power is a few percent below the value “Peak Incident Power” multiplied by “Duty Factor”. For example, if PIP=200 Watts and Duty Factor is 10%, then an expected power reading would be approximately 15 to 17 Watts.
 - Contact Covaris or your local representative for assistance.
- Degas Pump problems:
 - Verify that the water is clear and free of algae or other particulates. Perform a cleaning protocol with 10% bleach or equivalent solution if this has not recently been done.
 - Verify that the degassing pump is operating (observe the pump outlet on the left side of the tank – when the pump is running there should be occasional bubbles exiting the pump outlet tube). Also examine the inlet “dip tube” visible from the right side of the tank. The inlet holes (very small drilled holes in the side of the tube) should be free of obstruction.
 - If the degas pump makes a very loud noise when operating, it may need to be replaced.
- Particulates in bath water
 - Change the bath water with fresh DI water
 - Perform a cleaning protocol with a 10% bleach or equivalent solution if this has not recently been done.
- Tube Breakage
 - Verify that the acoustic parameters being employed are correct.
 - Verify that average power levels are approximately correct (see Power Level).
- RF Board Limits Exceeded Error:
 - If Peak Incident Power is set to values above 400 Watts, intense acoustic reflections may cause an overload in the electronic circuits driving the transducer. To protect the drive circuits and transducer, the system may shut down and post a message, “RF Board Limits Exceeded RF Error is Present”. Should this error appear, please retry your application with the following modifications:
 - Fill the sample tube to eliminate splashing and large bubble formation in the sample
 - Replace the existing bath water with new, clean bath water
 - Lower the PIP (Peak Incident Power) – this is often more effective than applying very high power.

Repeat the method to verify that overload problems have been mitigated. If not, please contact Covaris or your local representative.

Technical Support – Ongoing assistance with the operation or application of the equipment and/or troubleshooting is provided via:

- Telephone
 - United States: Tel: +1 781.932.3959 during the hours of 9:00 a.m. to 5:00 p.m., Monday through Friday, Eastern Standard Time (EST), Greenwich Mean Time (GMT-05:00)
 - Europe: Tel: 44 (0) 845 872 0100, during the hours of 9:00 a.m. to 5:00 p.m., Monday through Friday, Greenwich Mean Time
- E-mail queries to techsupport@covaris.com or applicationsupport@covaris.com

9. Appendix

Appendix A: LE220 (-plus and R-plus) Series Site or Transport Preparation

Placement of Equipment

The area required for the instrument (see drawing below) is approximately 41" wide by 30" deep by 21" high (104 cm x 76 cm x 53 cm). Leave sufficient space beside the instrument and behind the instrument for cooling fan exhaust. Do not block rear panel vents or fans. The ultraCUBE may be placed under the bench.

Power Requirements

Provide at least four standard outlets, one for the laptop computer, one for the LE220-plus, one for the CH05, and one for the WCS 2.0.

Your system draws a maximum of 12.5A. All components are configured with universal power supplies. *Note:* to avoid derating the CH05 cooling capacity, the CH05 may be used with a step-up transformer if operated at less than 115 VAC.

WARNING: To prevent the possibility of electrical shock, always plug the system into a grounded power source.

Water Requirements

The instrument's water bath requires about 5.0 liters of either deionized or distilled water, which should be topped up daily. The water should be changed and cleaning protocol with 10% bleach or equivalent solution performed at least once a month.

Relocating of the System

When moving the instrument within a laboratory, or between nearby laboratories, please employ the following guidelines:

- Perform the System Shutdown process described earlier in this manual.
- Close SonoLab and shut down the computer.
- Disconnect power cords and USB cable. Disconnect the ultraCUBE.
- Drain the water tank and reinstall in the instrument. Please contact Covaris or your local representative for assistance.
- Upon arrival at the new location, follow the Setup and Installation instructions described earlier in this manual.

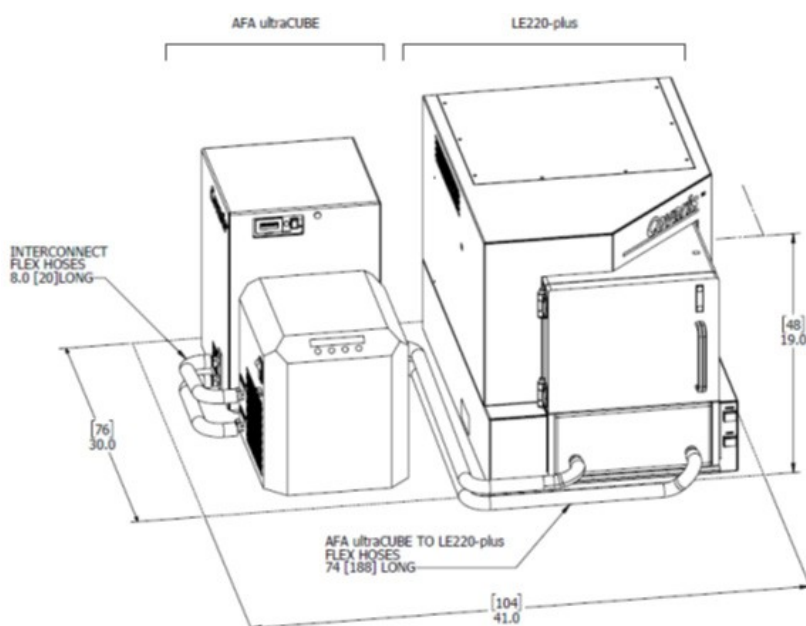

Appendix B: Installing SonoLab 8 and Required Support Software

These instructions are only for installing SonoLab 8 and other required software packages on a new computer. Do not use these instructions for an incremental upgrade from one version of SonoLab 8 to a newer version. For an upgrade, simply uninstall the existing version of SonoLab 8 using the Windows Uninstall Program control panel. Then install the new version by double-clicking its “setup” file.

1. Install 210063 SQL Server Express, Covaris Part Number 210063

Double-click the “SQLServer2016-SSEI-Expr.exe” file to start the installation. Confirm you wish to install, if prompted. The Express Edition window will display.

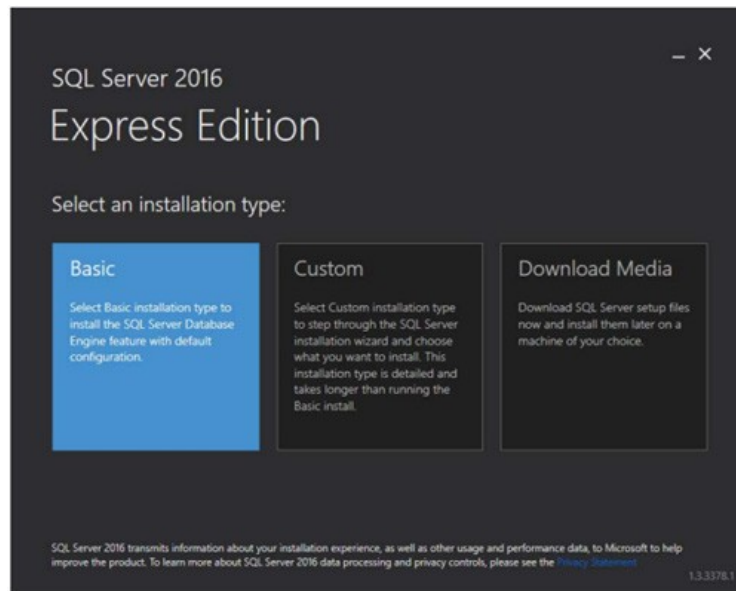

Click “Basic” to install the default version of SQL Server. Accept the license terms when prompted.

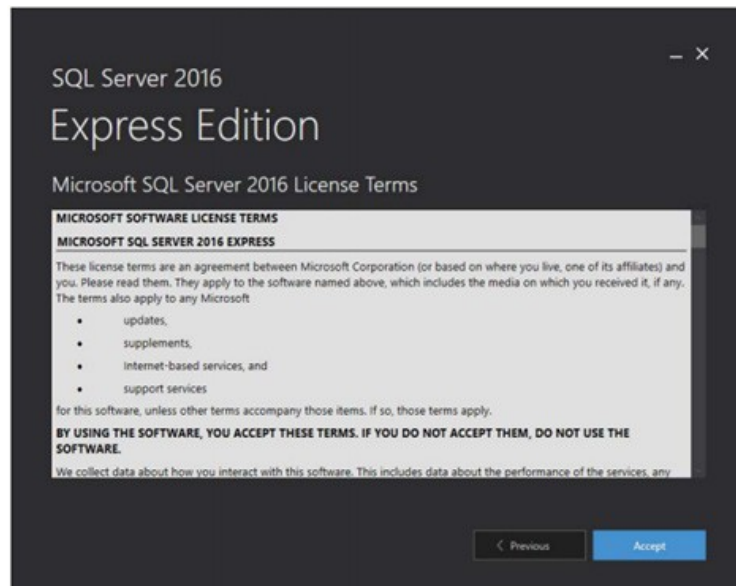

Accept license agreement.

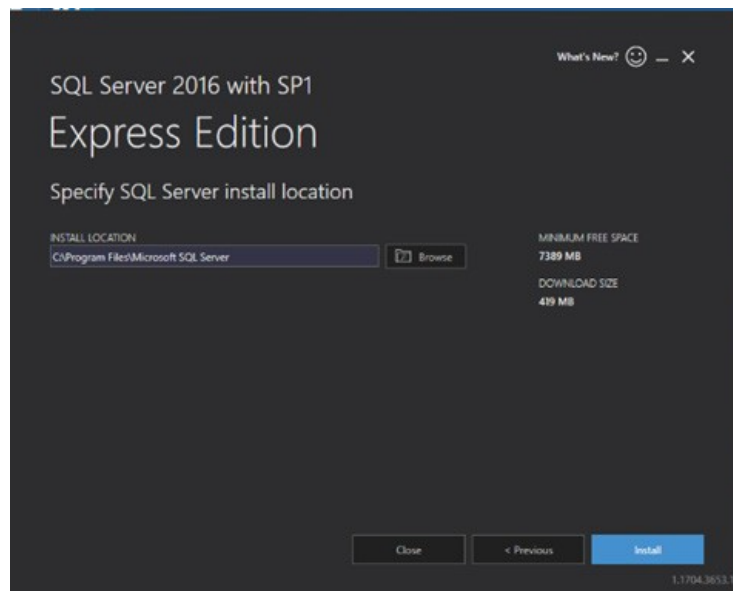

Accept default location.

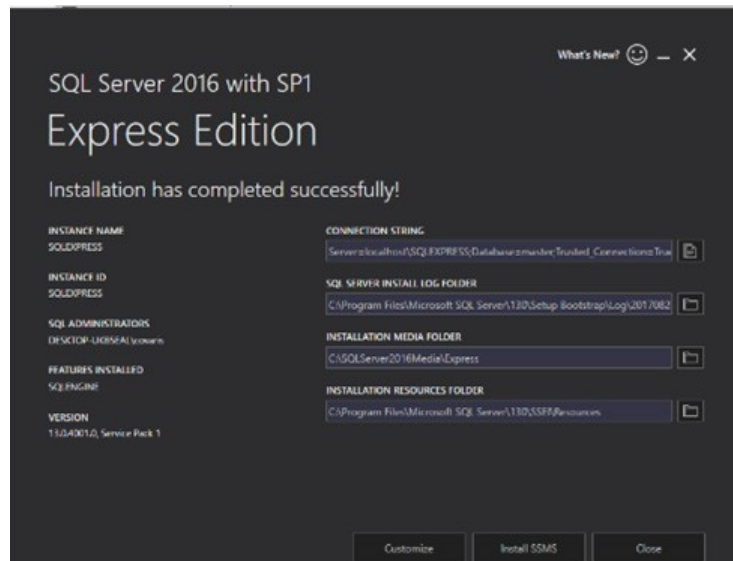

Click Close when installation is completed.

2. Install 210064 Server Management Studio

Double-click the “SSMS-Setup-ENU.exe” file to run the installation.

3. Install 210061 SonoLab 8.3

Double-click the “Setup.exe” file. Accept the defaults when prompted.

4. Install 210079 Baluff RFID Driver

Copy entire 210079 folder to desktop, open and double-click the “BalluffVCPInstaller_x64.exe” file to run the installation.

5. Install 210062 Plate Installer

Copy the contents of the 210062 Plate Definition Files folder “Plates_210062_revX” to:

C:\Users\Public\PublicDocuments\Covaris\SonoLab\Plates

Install Windows Instrument Driver

When an instrument (with power ON) is connected by USB (Universal Serial Bus) for the first time, Windows will identify the instrument by its Vendor and Product ID numbers and download from the internet and install specific device drivers (software files required for communications with a USB device).

- If an internet connection is not available, perform the manual driver installation as described below.

Manual driver installation: If the automatic installation fails to occur, Windows will post the following message:



Click on the Windows Start button. Either via Control Panel, or by right-clicking on Computer and choosing Properties, locate Device Manager. Click on this link to open the Device Manager window. In the list of devices, locate Other devices and entries for RF Controller Board:

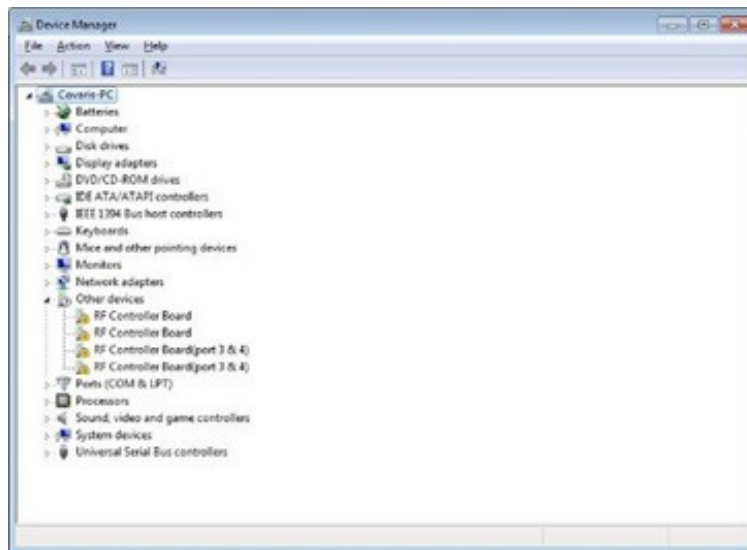

Under Other devices, right click first device RF Controller Board and select Update Driver Software:

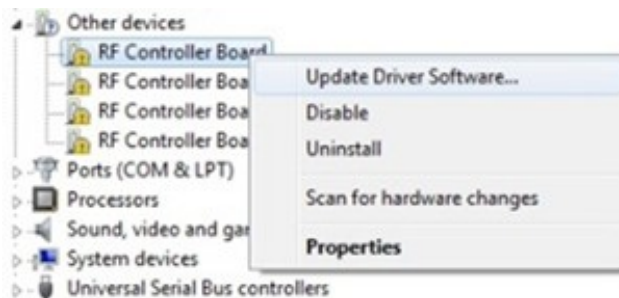

When the driver software update dialog opens, select the option to Browse my computer for driver software:

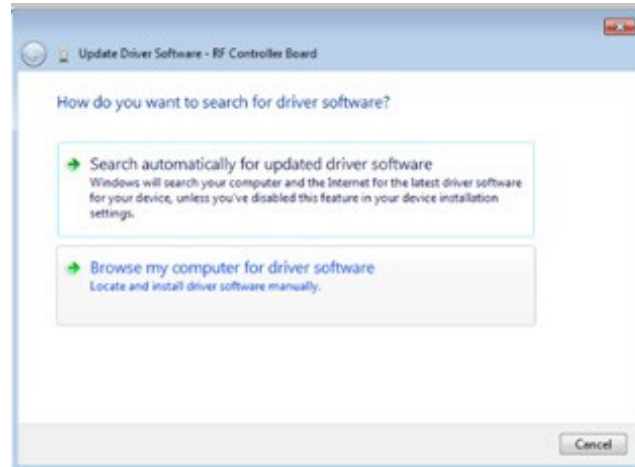

Point the file open dialog to "C:\Program Files(x86)\Covaris\Driver" and verify that "Include subfolders" is checked:

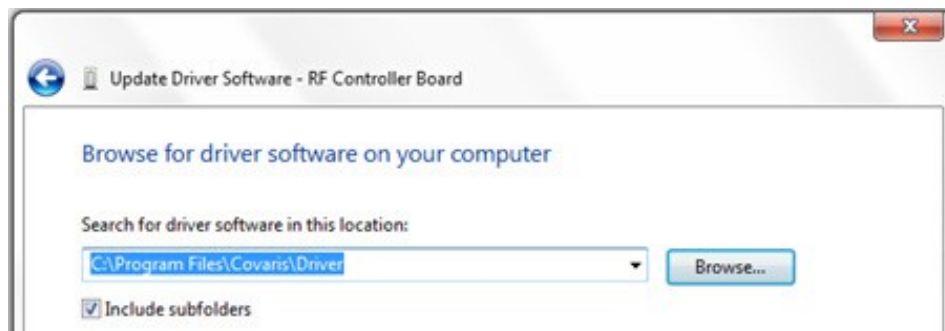

Windows will install the driver and post the following dialog box with a message, "Windows has successfully updated your driver software".

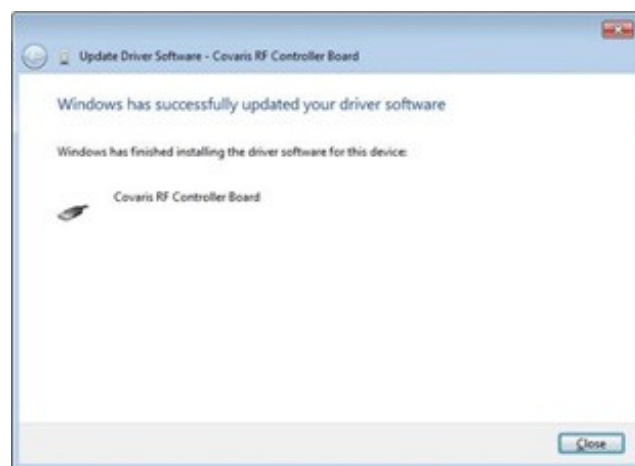

Click the Close button. The Device Manager screen will refresh.

Return to Other devices. Note that there is now a 'USB Serial Port' listed under the three 'RF Controller' lines. Right-click on the 'USB Serial Port' and select 'Update Driver Software...', as shown in the image below. Repeat the installation steps shown above.

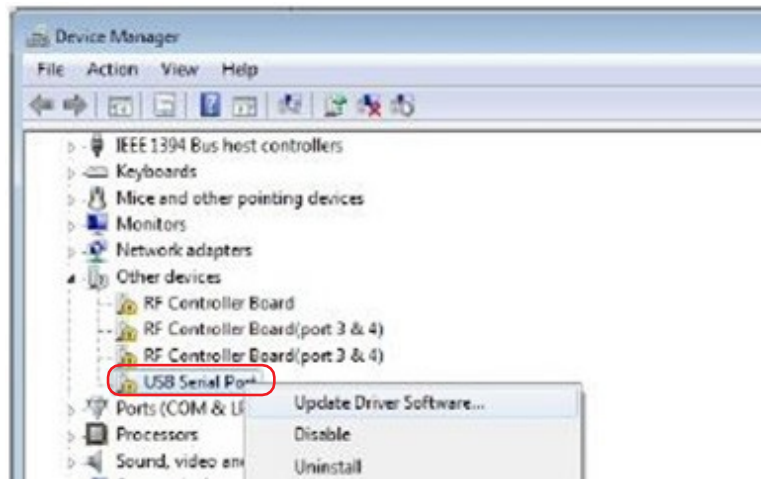

Return to Other devices and repeat this process in order (top to bottom), for the 3 remaining entries, until all Covaris device entries have been assigned a COM number under Ports (COM & LPT). The 'Device Manager' window should now show:

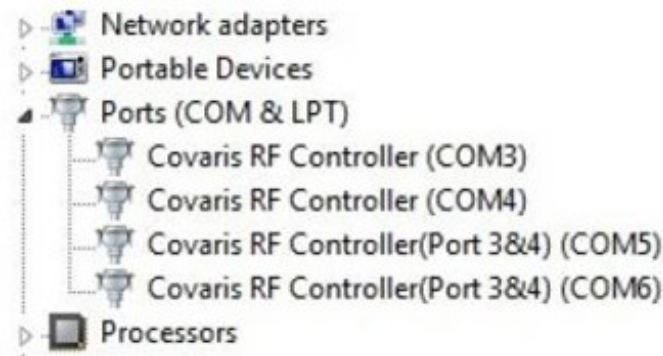

Note that the 'COM' numbers will vary from computer to computer but should occupy four consecutive ports.

Launching SonoLab 8 for the first time

1. Launch SonoLab 8 and *WAIT* for the message box to appear. It might take a couple of minutes to establish a database connection for the first time.
2. *(DO NOT DOUBLE CLICK ON THE ICON THE SECOND TIME. THIS CAN CREATE MULTIPLE INSTANCES OF THE DATABASE AND CAUSE CONNECTION ERRORS)*
3. Log in using the default user "Administrator, password "admin". Both the user and password are case sensitive.
4. SonoLab 8 starts.

Appendix C: Humidity and Water Management for the Covaris LE220-plus

Your Covaris instrument employs a six-liter tank of distilled or deionized water located inside the instrument housing. For the system to operate correctly, the water must be filled to an appropriate level, clean, free of algae growth, and degassed to retard bubble formation in the acoustic field outside of the sample vessel. Additionally, bath temperature is controlled by the Covaris ultraCUBE connected to your system's water bath. Managing this water and relative humidity is important for the correct operation and reliability of your Covaris system. The following suggestions will help:

- When the system is powered on, the interior is vented by fans located in the rear panel to maintain an appropriate air temperature and humidity within the instrument enclosure. It is recommended, when the acoustic tank is full, that the instrument be left with power on, so that these fans run and retard water condensation on interior surfaces. If it is not practical or desirable to leave these fans running when the instrument is not in use, please leave the front access door ajar so that interior air may exchange with ambient air. The risk of condensate forming within the instrument is increased when operating with a Water Conditioning System 2.0 (WCS), because the WCS will add a small amount of heat to the bath water.
- The WCS 2.0 precludes the need for a daily change of bath water. It is, however, important that water which evaporates each day be made up with fresh distilled or deionized water. It is also important that a monthly cleaning protocol with bleach or equivalent solution continue to be followed, as the WCS 2.0 will retard but cannot completely prevent algae from taking hold in hoses and interior tank surfaces. Detach the WCS water flow from system when cleaning with bleach or equivalent.
- When the system is being operated at a low temperature, you may notice condensate water forming on the black manifold block, on hoses leading to the degas pump, and around the fittings and chassis of the WCS 2.0. Particularly in summer, when relative humidity is higher, condensate may drip onto interior surfaces and small amounts may leak onto the laboratory bench. This condensation is expected, and no harm is being done to the system. Excess condensate dripping onto a laboratory bench may be captured by placing an absorbent pad (e.g. VWR 82020-845) beneath the system and/or WCS.
- If the instrument is going to be idle for more than 2 weeks, it may be beneficial to turn all components off to prevent any damage to the instrument. Please follow the recommended sequence:
 1. Turn off chiller
 2. Move instrument to service position
 3. Turn off the ultraCUBE and disconnect hoses
 4. Empty the water tank
 5. Replace the water tank and move instrument to load position
 6. Purge the degas pump by turning on for 10 seconds. Purge the ultraCUBE lines by connecting the hoses and powering on ultraCUBE until flow subsides
 7. Turn the WCS off and disconnect hoses. Raise instrument to service position.
 8. Empty the water tank and dry
 9. Gently dry transducer and surfaces of instrument

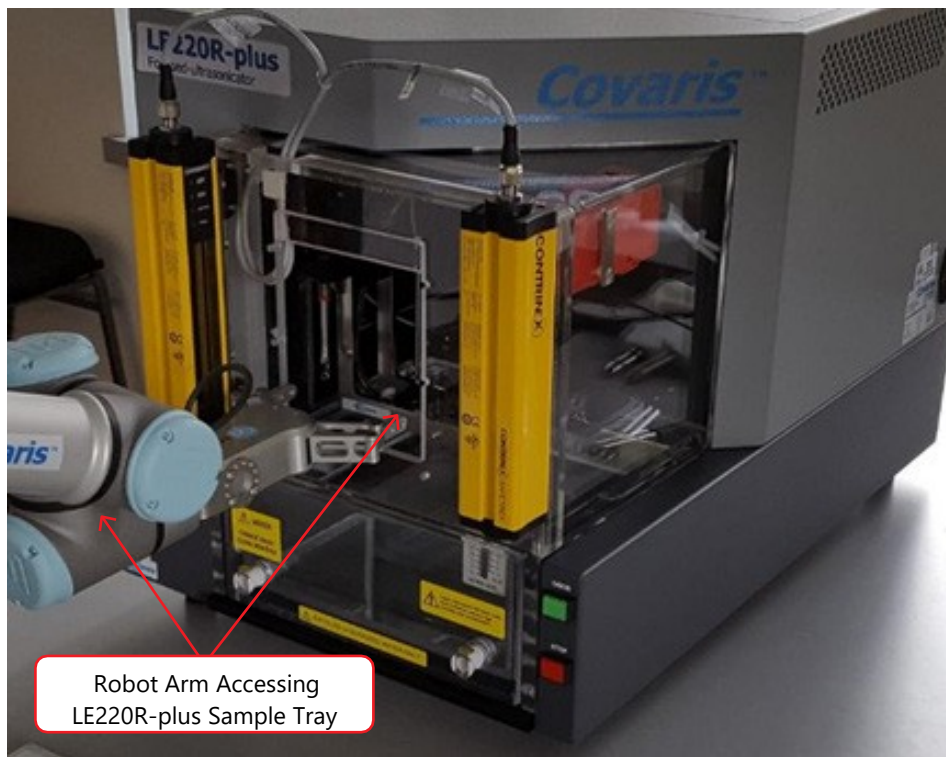

Appendix D: Connecting AutoFill to Plant Water

The AutoFill Accessory Kit is provided to facilitate connecting plant DI water to the AutoFill hardware of your system. The accessory kit includes a 5 micron particulate filter, an adjustable pressure regulator, 10 feet of 6 mm OD polyethylene tubing, and the fittings necessary to connect the components.



Determine the most convenient locations for the pressure regulator and particulate filter. The regulator assembly is connected directly to plant water, with the particulate filter between the regulator and the AutoFill port on the side of your system.

Based on the filter and regulator locations, cut three pieces of the provided poly tubing to appropriate lengths. One piece connects plant water to the regulator, the second piece connects the outlet of the regulator to the inlet of the particulate filter, and the third piece connects the outlet of the particulate filter to the AutoFill inlet on the side of your system.

Assemble a male quick-disconnect fitting to one end of the tube from the filter to your system and to one end of the tube from the regulator to the filter. Refer to image below.



Install the tube from the regulator to the filter by sliding the open tube end into the push-to-connect fitting at the outlet of the regulator and clicking the other end of the tube into the inlet of the particulate filter.

Repeat the above step for the tube from the filter to the inlet port on your system.

Remove the red plug from the AutoFill inlet port on the side of your system and insert the line from the outlet of the filter.

Turn the regulator adjusting knob fully counter-clockwise and connect plant water to the AutoFill. Adjust the regulator to obtain a maximum of 30 psi water pressure. Verify that there are no leaks.

CAUTION: All AutoFill components have pressure ratings above Covaris' specified maximum operating pressure and have been tested extensively. However, a catastrophic failure would result in substantial plant water spillage. It is the customer's responsibility to specify and implement appropriate containment/alarm schema for their facility.

Addendum for LE220Rsc

Covaris developed the LE220Rsc to allow scanning treatments of 96 and 384 well plates. This requires additional travel front-to-back (X axis) of which the LE220R-plus is not capable. To accomplish the extra range of motion, the LE220Rsc employs an X axis motion stage with an additional inch of travel. The extra travel is accommodated by a longer water bath and safety enclosure, which now extend slightly out the front of the instrument. To minimize additional length, the chiller connections are moved from the front to the side of the water bath.



Setting up the LE220Rsc is the same as for a conventional LE220R-plus except for the connections to the ultraCUBE Chiller/Water Conditioning System. The upper hose from the WCS 2 must connect to the lower fitting of the water bath. The temperature sensor for the water bath is adjacent to the two hose connections. The lower hose fitting contains a long tube to bring the cooled (heated) water from the chiller away from the temperature sensor to prevent an erroneous temperature reading.

