

6000 Series Gaussmeter Probes

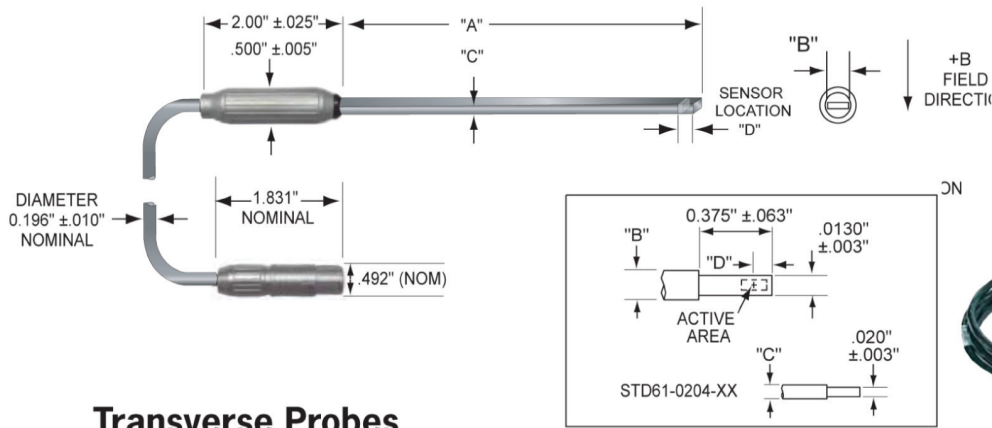

Transverse Probes

Model	A ±.063"	B	C	D	Material	Corrected Linearity	Sens.	Active area	Op. temp. range	Temp. stability (max)		Frequency Response
										Zero	Calibrate	
HTD61-0608-05-T	8"	0.180" ±.003"	0.060" +.000" -.004"	0.150" ±0.020"	ALUMINUM 3003 3/4 FH	0.5%/30kG	1X	0.070" Dia. (NOM)	0°C to +75°C	±0.300 Gauss / °C (TYP)	-0.05 % / °C (TYP)	DC to 20kHz
HTD61-0608-15-T												
HTD61-0608-30-T												
HTD61-0608-05												
HTD61-0608-15												
HTD61-0608-30												
HTR61-0608-05	4"	0.158" ±.004"	0.045" ±.004"	0.130" ±0.008"	POLYPRO- PYLENE	0.5%/30kG	1X	0.040" Dia. (NOM)	0°C to +75°C	±0.300 Gauss / °C (TYP)	-0.05 % / °C (TYP)	DC
HTR61-0608-15												
HTR61-0608-30												
STD61-0404-05												
STD61-0404-15												
STD61-0404-30												
STD61-0402-05	2"	0.155" ±.005"	0.040" +.002" -.009"	0.130" ±0.008"	**SEE NOTE	0.5%/30kG	1X	0.070" Dia. (NOM)	0°C to +75°C	±0.300 Gauss / °C (TYP)	-0.05 % / °C (TYP)	DC to 20kHz
STD61-0402-15												
STD61-0402-30	4"	0.155" ±.005"	0.040" +.002" -.009"	0.130" ±0.008"	FLEXIBLE RUBBER	0.5%/30kG	1X	0.070" Dia. (NOM)	0°C to +75°C	±0.300 Gauss / °C (TYP)	-0.05 % / °C (TYP)	DC to 20kHz
STD61-0204-05												
STD61-0204-15												
STD61-0204-30												

Note: ** Prior to late 2006 Transverse Probe Stems were rigid glass epoxy, .150 x .040".
Due to continuous process improvement, specifications are subject to change without notice.

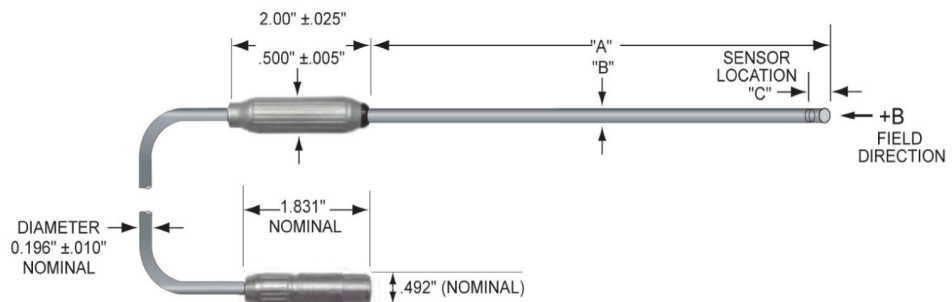

Axial Probes

Model	A ±.063"	B	C	Material	Corrected Linearity	Sens.	Active area	Op. temp. range	Temp. stability (max)		Frequency Response
									Zero	Calibrate	
HAD61-2508-05-T	8"	0.250" ±.005"	0.015" ±0.010"	ALUMINUM 3003 3/4 FH	0.5%/30kG	1X	0.030" Dia. (NOM)	0°C to +75°C	±0.300 Gauss / °C (TYP)	-0.05 % / °C (TYP)	DC to 20kHz
HAD61-2508-15-T											
HAD61-2508-30-T											
HAD61-2508-05											
HAD61-2508-15											
HAD61-2508-30											
SAR61-1802-05	2"	0.180" +.002" -.007"		RIGID PHENOLIC	1.0%/100kG	10X					DC
SAR61-1802-15											
SAR61-1802-30											

6000 Series Gaussmeter Probes



Ultra Thin Hall-Effect Probe

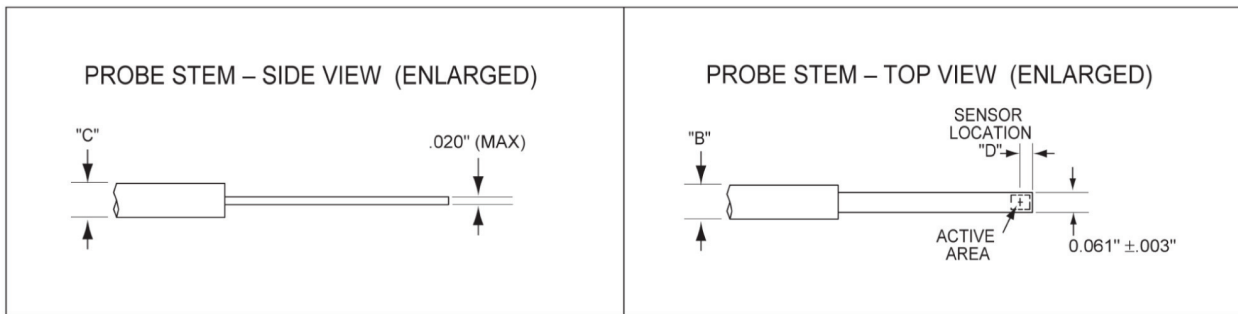
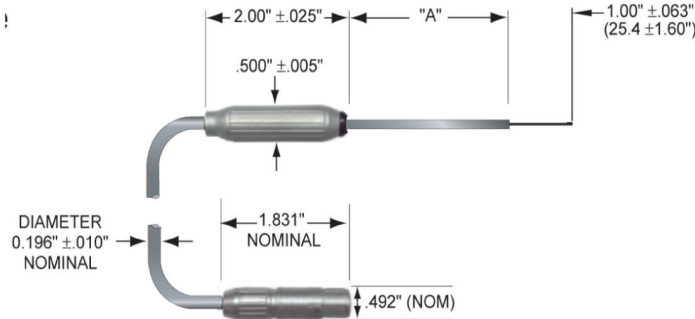

Model	A ±0.63"	B	C	D	Material	Corrected Linearity	Sens.	Active area	Op. temp. range	Temp. stability (max)		Frequency Response
										Zero	Calibrate	
STD61-0202-05	2"	0.155" ±.005"	0.040" +.002" -.009"	0.020" ±.001"	G10 RIGID GLASS EPOXY & KAPTON TIP	0.5%/30kG	1X	0.005" Dia. (NOM)	0°C to +75°C	±0.55 Gauss / °C (MAX)	-.07 % / °C	DC to 200Hz
STD61-0202-15												
STD61-0202-30												

Magnaprobe (low field)

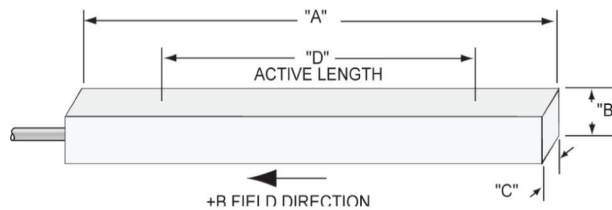

Model	A	B	C	D	Material	Corrected Linearity	Sensitivity	Active area	Operating temp. range	Temp. stability (max)		Frequency Response
										Zero	Calibrate	
MOW61-2506-05	9" ±.030"	0.480" ±.030"	0.250" ±.010"	6"	Lexan	±4%/2G	.01X	6" X .25" (NOM)	0°C to +75°C	±0.001 Gauss / °C	-0.05 % / °C	DC to 400Hz
MOW61-2506-15												
MOW61-2506-30												

Note: Due to continuous process improvement, specifications subject to change without notice.

Pacific Scientific-OECO | 4607 SE International Way | Milwaukie, OR 97222 | www.oeco.com