

Pressure switches
 Pressostats
 Druckwaechter
 Pressostatos
 Pressostati
 Pressostatos

XMx

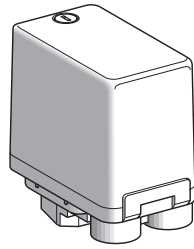

XMA

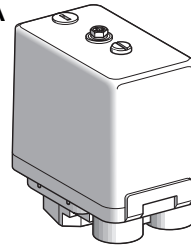

XMP

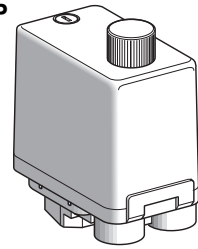

⚠ DANGER / DANGER / GEFAHR / PELIGRO / PERICOLO / PERIGO

HAZARD OF ELECTRIC SHOCK, EXPLOSION, OR ARC FLASH

Disconnect all power before servicing equipment.

Failure to follow these instructions will result in death or serious injury.

RISQUE D'ELECTROCUTION, D'EXPLOSION OU D'ARC ELECTRIQUE

Couper l'alimentation avant de travailler sur cet appareil.

Le non-respect de ces instructions provoquera la mort ou des blessures graves.

STROMSCHLAG-, EXPLOSIONS- ODER LICHTBOGENGEFAHR

Vor dem Arbeiten an dem Gerat dessen Stromversorgung abschalten.

Die Nichtbeachtung dieser Anweisungen fuhrt zu Tod oder schwerer Korperverletzung.

RIESGO DE ELECTROCUCI3N, EXPLOSI3N O ARCO EL3CTRICO

Desconecte toda alimentaci3n antes de realizar el servicio.

Si no se siguen estas instrucciones provocar lesiones graves o incluso la muerte.

RISCHIO DI SCOSSA ELETTRICA, DI ESPLOSIONE O DI OFTALMIA DA FLASH

Scolligare l'apparecchio dalla presa di corrente prima di qualsiasi intervento.

Il mancato rispetto di queste istruzioni provocher morte o gravi infortuni.

RISCO DE CHOQUE EL3CTRICO, EXPLOSA3O OU FAISCA

Scolligare l'apparecchio dalla presa di corrente prima di qualsiasi intervento.

A no observncia destas instru33es resultar em morte, ou ferimentos graves.

Dimensions - Encabrements - Abmessungen - Dimensiones - Dimensioni - Atravancamentos

1mm = 0.0394in.

XMx/XMP-A06•21••/A12•21••

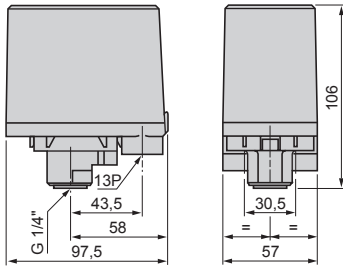

XMx/XMP-A06•24••/A12•24••

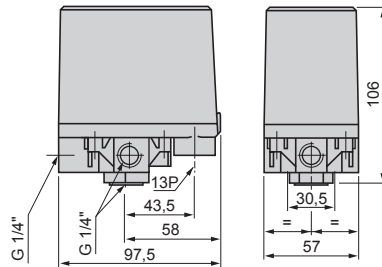

XMx/XMP-A25•21••

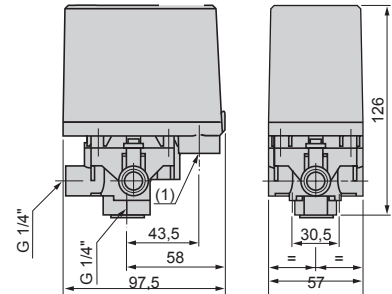

XMA-•06•21••/XMA-•12•21••

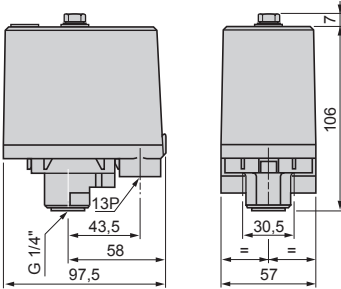

XMA-•06•24••/XMA-•12•24••

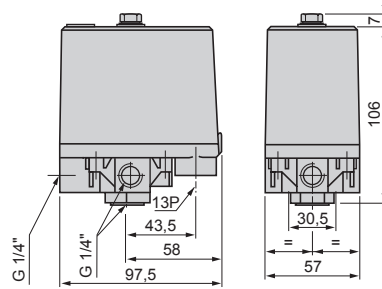

XMA-•25•21••

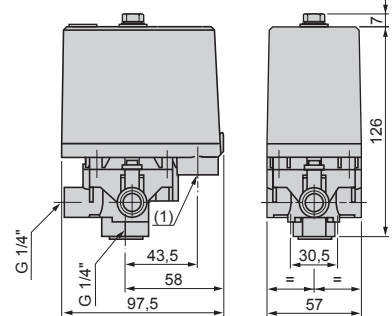

XMP-D/E06/12•••••

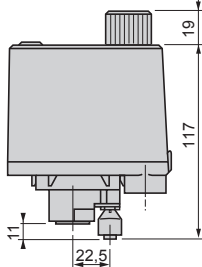

XMP-R06/12•••••

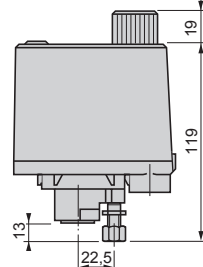

XMP-R25•••••

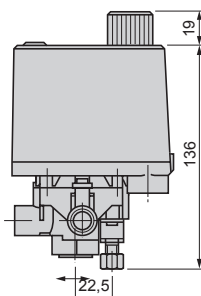

XMP-B/C•••••

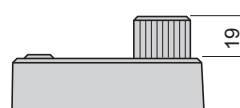

XMx/XMAXMP

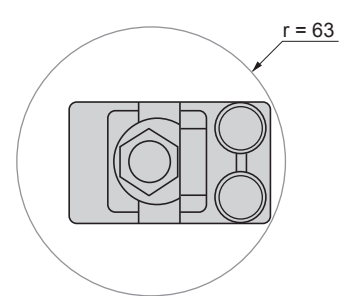

- EN Electrical equipment should be installed, operated, serviced, and maintained only by qualified personnel. No responsibility is assumed by Schneider Electric for any consequences arising out of the use of this material.
 - FR Les quipements lectriques doivent tre installs, exploits et entretenus par un personnel qualifi. Schneider Electric dcline toute responsabilit quant aux consquences de l'utilisation de ce matriel.
 - DE Elektrische Gerate durfen nur von Fachpersonal installiert, betrieben, gewartet und instand gesetzt werden. Schneider Electric haftet nicht fur Schaden, die aufgrund der Verwendung dieses Materials entstehen.
-  2012 Schneider Electric. "All Rights Reserved."

- ES S3lo el personal de servicio cualificado podr instalar, utilizar, reparar y mantener el equipo elctrico. Schneider Electric no asume las responsabilidades que pudieran surgir como consecuencia de la utilizaci3n de este material.
- IT Le apparecchiature elettriche devono essere installate, usate e riparate solo da personale qualificato. Schneider Electric non assume nessuna responsabilit per qualunque conseguenza derivante dall'uso di questo materiale.
- PT O equipamento elctrico s3 deve ser instalado, utilizado e reparado por tcnicos especializados. A Schneider Electric no assume qualquer responsabilidade por quaisquer consquncias decorrentes da utiliza33o deste material.

XM●●06

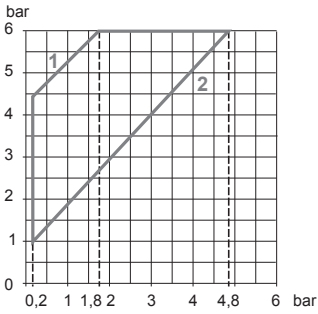

XM●●12

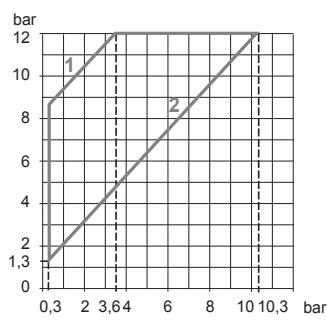

XM●●25

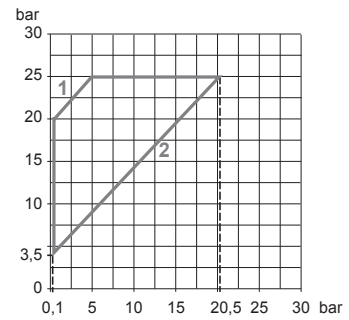

1 : Maximum differential - Ecartx maximaux - Maximale hysteresen - Intervalos máximos - Differenziali max - intervalos maximos
 2 : Minimum differential - Ecartx minimaux - Minimale hysteresen - Intervalos mínimos - Differenziali min - intervalos mínimos

XMx/XMA

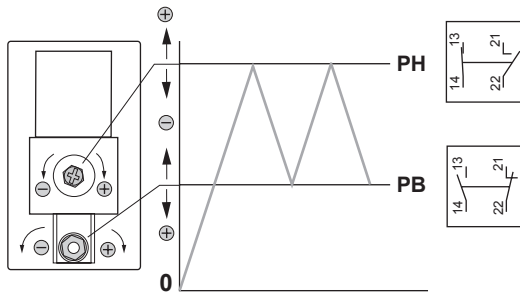

XMP

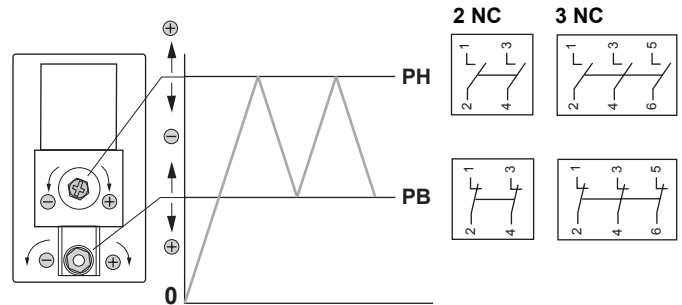

PH : High setting point - Point haut - Oberer Schalterpunkt - Punto de disparo superior - Punto di scatto superiore - Ponto alto
 PB : Low setting point - Point bas - Unterer Schalterpunkt - Punto de disparo inferior - Punto di scatto inferiore - Ponto baixo

Setting
 Réglage
 Einstellungen
 Adjustes
 Regolazione
 Reglage

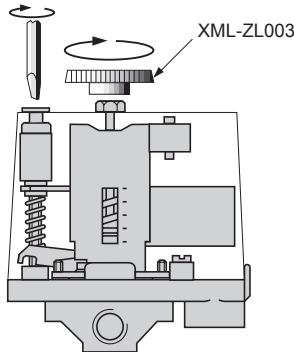

Fixing bracket
 Equerre de fixation
 Befestigungswinkel
 Escuadra de fijación
 Squadra de fissaggio
 Esquadro de fixaçao

XMA ZL001

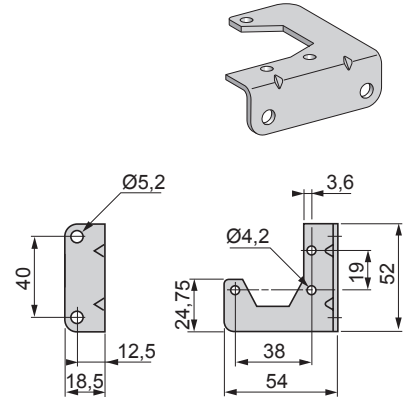

1mm = 0.0394in.

CAUTION / ATTENTION / VORSICHT / AVISO / ATTENZIONE / ATENÇÃO

<p>Equipment damaged</p> <p>Use the equipment within the characteristics mentioned in catalogue</p>	<p>Équipement endommagé</p> <p>Utilisez l'équipement en respectant les caractéristiques mentionnées dans le catalogue.</p>	<p>Gerät beschädigt</p> <p>Verwenden Sie das Gerät innerhalb der im Katalog aufgeführten Kenndaten</p>
<p>Failure to follow these instructions can result equipment damage.</p>	<p>Le non-respect de ces instructions peut provoquer des dommages matériels.</p>	<p>Die Nichtbeachtung dieser Anweisungen kann zu Materialschäden führen.</p>
<p>Equipo dañado</p> <p>Utilice el equipo dentro de los límites de las características que se mencionan en el catálogo</p> <p>Si no se siguen estas instrucciones pueden producirse daños en el equipo.</p>	<p>Apparecchiatura danneggiata</p> <p>Utilizzare l'apparecchiatura secondo le caratteristiche citate nel catalogo</p> <p>Il mancato rispetto di queste istruzioni può danni alle apparecchiature.</p>	<p>Equipamento danificado</p> <p>Utilize o equipamento dentro das especificações mencionadas no catálogo</p> <p>A não observância destas instruções pode danos no equipamento.</p>