

# FLOAT SWITCHES

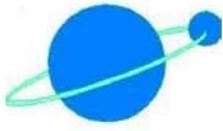

## LR03 – NON MERCURY LEVEL REGULATORS

Float Switches are inexpensive and efficient liquid level detectors. They are simple to install, and designed for trouble free operation over a long life. The LR03 is a plastic float switch moulded to either a PVC or synthetic rubber 3 core cable. Actuation is via a roller ball and micro-switch arrangement within the switch thereby eliminating all heavy metals from this version.

### **Construction**

The unit comprises three major components :

1. The float chamber houses the micro-switch arrangement, totally sealed within a polypropylene casing, with a single pole double throw action.
2. The three-cored cable, connected to the micro-switch assembly inside the float chamber, is sheathed in CPE (chlorinated polyethylene) synthetic rubber or PVC. This cable is supplied in three standard lengths, 5 metres, 10 metres and 20 metres  $\pm 5\%$  of the length quoted.  
Other cable lengths are available to order.
3. The optional stabilizing weight may be fixed at any point on the cable using the rubber “O” ring supplied. The weight is sealed within a moulded polypropylene housing.  
In order to provide total positional security in lubricants and similar liquids, a nylon cable-tie is provided for attachment to the cable beneath the weight

### **Mounting**

Whilst no hard and fast rules apply to the mounting of these units, the lead should be supported in an enclosed vessel, and in an open vessel it is advantageous to clip the lead to the side, especially if excessive turbulence is experienced.

To obviate the effects of rapid switching conditions that would result if such turbulence is experienced, it is advantageous to use a maintaining circuit which both safeguards the micro-switch and cuts out any chatter in the starters of associated pumps etc

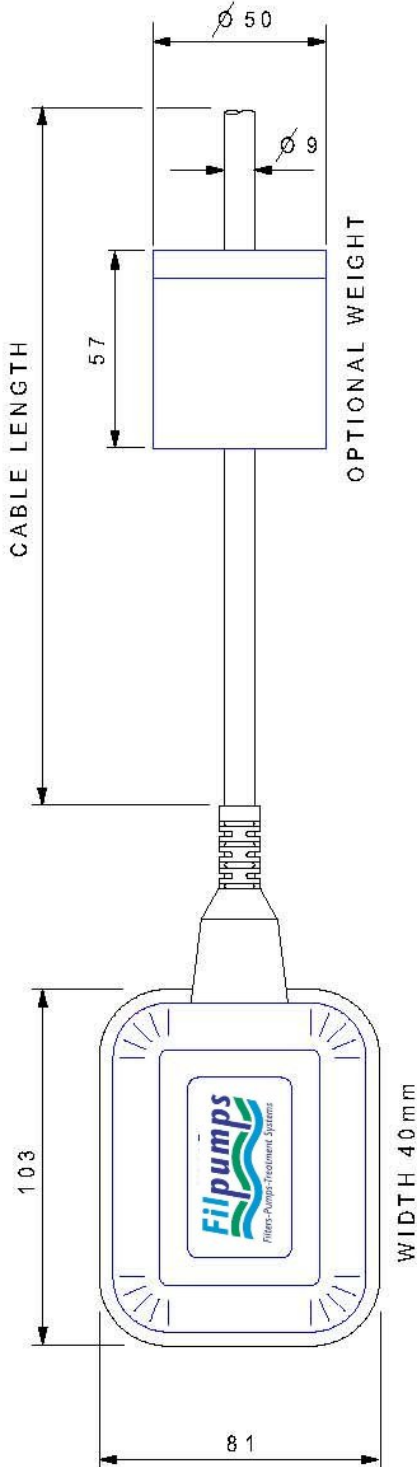

# LR03 - PLASTIC FLOAT SWITCH

## Method of Operation

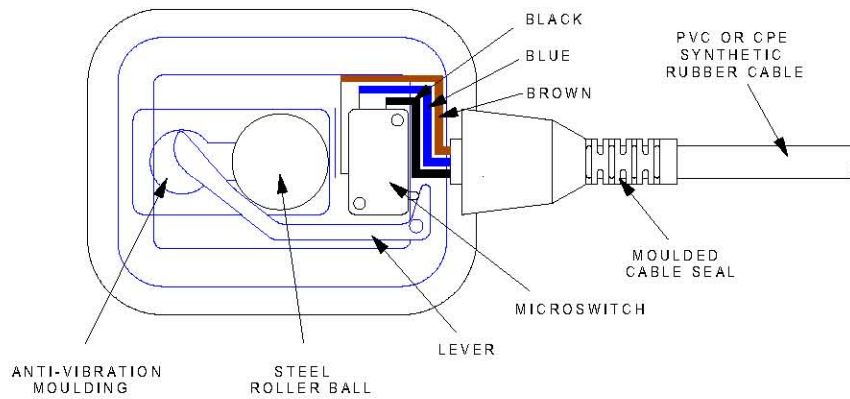

The micro-switch assembly inside the float, axially mounted in line with the weight, changes contacts according to the float's position, as in the diagram below. Therefore as the liquid level drops or rises slowly, a pump or flow control suitably connected, can be switched in or out to maintain an average level of the liquid. By connecting only one side of the switch, the unit can be also used to fill or empty the tank as required.

**Dimensions, in mm, do not take into consideration any lateral swing of the cable.**

Contact rating: 250V 15A, non-inductive.  
250V 10A, inductive. 1.3 HP

**NOTE:** Local Regulations may limit the voltage.

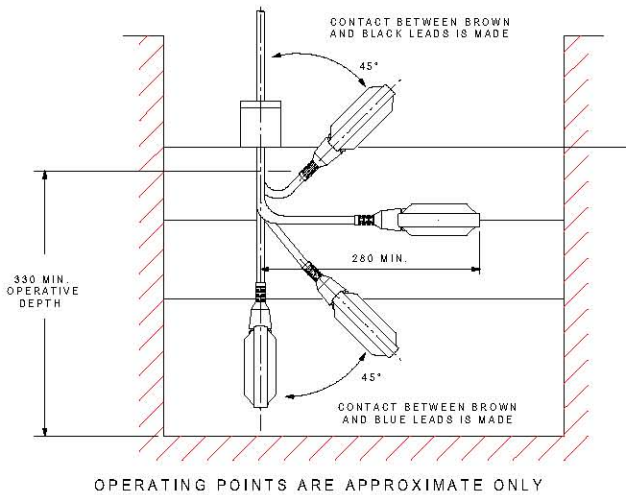

Max. temperature 70° C

Max. submerged depth 20 metres

Compressive Strength 482 KN/m<sup>2</sup> (70 lbf/in<sup>2</sup>)

Operational in specific gravities from 0.9 to 1.3

A comprehensive list of chemical resistances for the LR03 float switch is available on request.

LR03-Weight 275 g

### Connection diagram for automatically emptying tank

### Connection diagram for automatically refilling tank

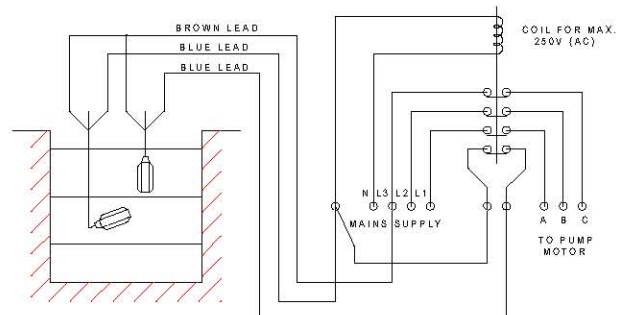
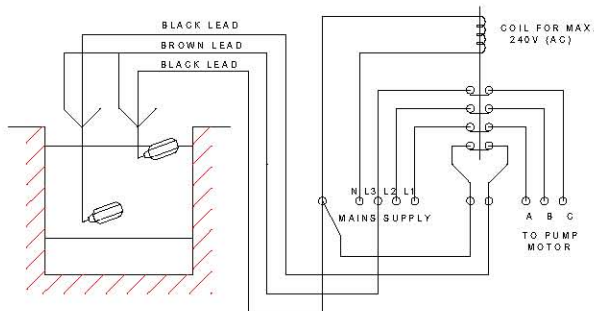

When ordering please specify part numbers.

Type	Part Number	Weight (Approx)	Type	Part Number	Weight (Approx)
5 metre PVC cable	LR03-L05M-PVC	0.6 Kg	5 metre CPE cable	LR03-L05M-CPE	0.6 Kg
10 metre PVC cable	LR03-L10M-PVC	1.1 Kg	10 metre CPE cable	LR03-L10M-CPE	1.1 Kg
20 metre PVC cable	LR03-L20M-PVC	2.1 Kg	20 metre CPE cable	LR03-L20M-CPE	2.1 Kg

NOM WEIGHT, 1 KG

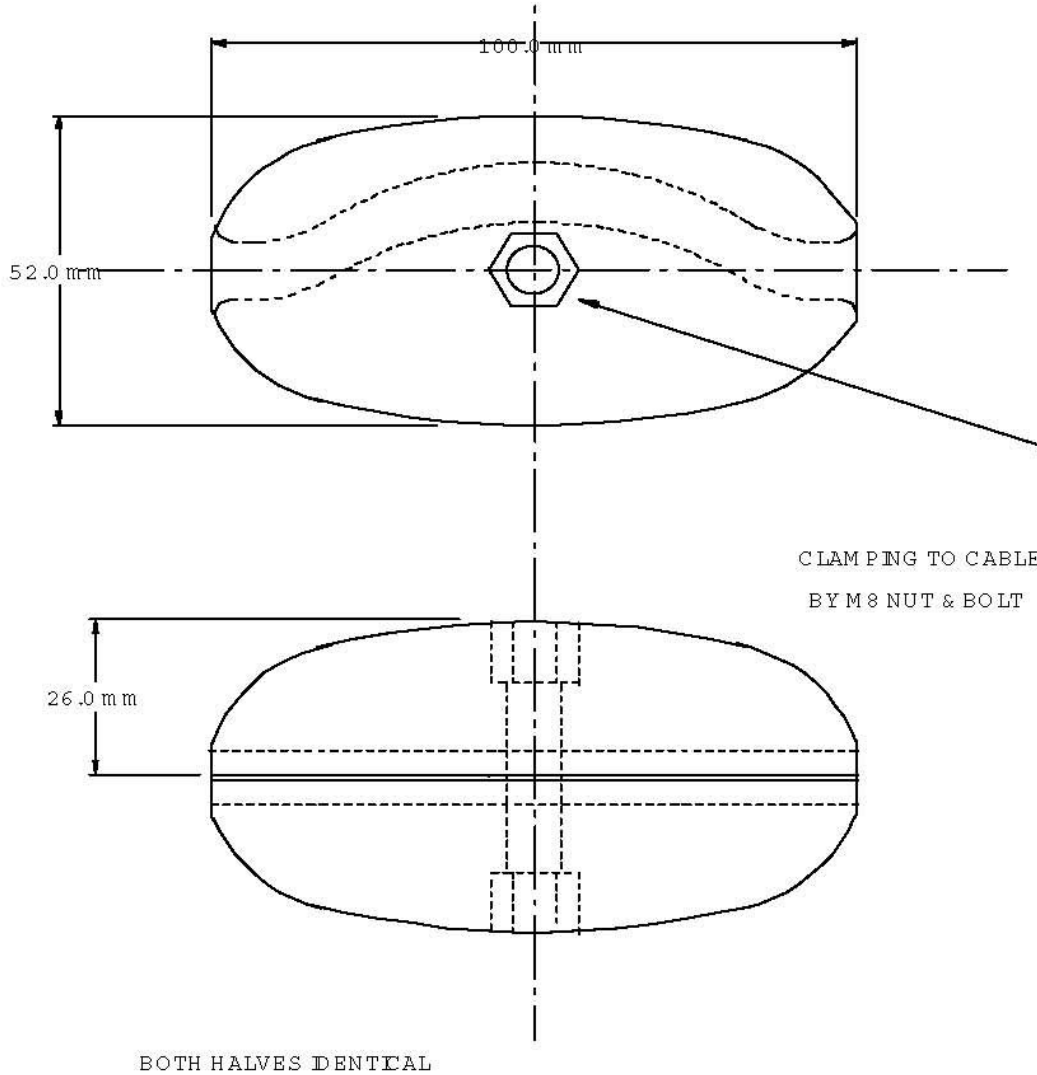

DIMENSIONS	mm	TOLERANCE	±0.4	DRAWN			
<b><u>BOLT-ON</u></b> <b><u>CAST IRON</u></b> <b><u>CABLE WEIGHT</u></b>				1	2	3	4
				041200			
				5	6	7	8
DRG No				DATE			
<b><u>LR03-W 2</u></b>				<b><u>04-12-00</u></b>			