



Service Manual

**HP Designjet
Z2100/Z3100
GP Photo Printer Series**



For HP Internal Use Only

©Copyright Hewlett-Packard Company 2006

This document contains proprietary information that is protected by copyright. All rights are reserved. No part of this document may be photocopied, reproduced, or translated to another language without the prior written consent of Hewlett-Packard Company.

First Edition, September 2006

Warranty

The information contained in this document is subject to change without notice.

Hewlett-Packard makes no warranty of any kind with regard to this material, including, but not limited to, the implied warranties of merchantability and fitness for a particular purpose.

Hewlett-Packard shall not be liable for errors contained herein or for incidental or consequential damages in connection with the furnishing, performance, or use of this material.

WARNING

The procedures described in this manual are to be performed by HP-qualified service personnel only.

Electrical Shock Hazard

Serious shock hazard leading to death or injury may result if you do not take the following precautions:

- Ensure that the ac power outlet (mains) has a protective earth (ground) terminal.
- Disconnect the Printer from the power source prior to performing any maintenance.
- Prevent water or any other liquids from running onto electrical components or circuits, or through openings in the enclosure.

Electrostatic Discharge

Refer to the beginning of Chapter 4 of this manual, for precautions you should take to prevent damage to the Printer circuits from electrostatic discharge.

Safety Symbols

General definitions of safety symbols are given immediately after the table of contents.

WARNING

The Warning symbol calls attention to a procedure, practice, or the like, which, if not correctly performed or adhered to, could result in personal injury. Do not proceed beyond a Warning symbol until the indicated conditions are fully understood and met.

CAUTION

The Caution symbol calls attention to an operating procedure, practice, or the like, which, if not correctly performed or adhered to, could result in damage to or destruction of part or all of the product. Do not proceed beyond a Caution symbol until the indicated conditions are fully understood and met.

Content Management Department,
Barcelona Division,
Hewlett-Packard Espanola, S.A.
Avda. Graells, 501
08190 Sant Cugat del Valles
Spain

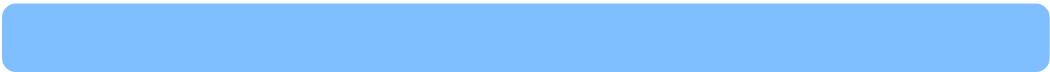

service manual

**HP Designjet
Z2100/Z3100
GP Photo Printer Series**

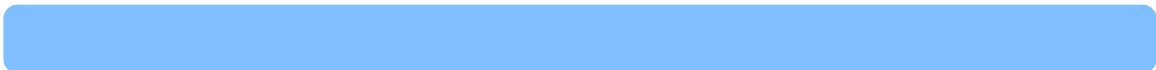

Using this Manual

Purpose

This Service Manual contains information necessary to test, calibrate and service:

- HP designjet Z2100 GP Photo Printer 24 inch (Model Q6675A)
- HP designjet Z2100 GP Photo Printer 44 inch (Model Q6677A)
- HP designjet Z3100 GP Photo Printer 24 inch (Model Q5669A)
- HP designjet Z3100 GP Photo Printer 44 inch (Model Q6659A)

For information about using these printers, refer to the corresponding User and Quick Reference Guides.

Readership

The procedures described in this Service Manual are to be performed by HP Certified service personnel only.

Part Numbers

Part Numbers for Printer options, accessories and service parts are located in Chapter 7.

Conventions

A small arrow \Rightarrow is used to indicate other parts of the Service Manual where you can find information related to the topic you are consulting.

Table of Contents

Troubleshooting 1-1

System Error Codes 2-1

Ink Supplies Troubleshooting 3-1

Service Tests and Utilities 4-1

Service Calibrations 5-1

Print Quality 6-1

Parts and Diagrams 7-1

Removal and Installation 8-1

Preventive Maintenance 9-1

Troubleshooting

7

- Introduction 1-2
- Troubleshooting System Error Codes 1-2
- Performing a Service Test on a failed Assembly 1-2
- Performing the Necessary Service Calibrations 1-2
- Solving Print Quality Problems 1-3
 - The Printer does not Power ON 1-3
 - The Printer Continuously Rejects Printheads 1-3
 - Cover Sensors are not Working 1-3
 - The Line Sensor has Problems Detecting Media 1-3
- Banding at variable extreme environmental conditions 1-4
- Worm marks on HP Coated media with light area fills 1-4
- Solving Media-Handling Problems 1-4

Guide to Troubleshooting the Printer

Introduction

This chapter will guide you through the relevant steps to take when troubleshooting the printer.

Troubleshooting System Error Codes

Chapter 2, *System Error Codes* contains a list of system error codes and their respective descriptions and recommended corrective actions. Only try one recommended action at a time and check if the error code has disappeared.

If you have an error code which is not documented in this Service Manual or you have an error which you cannot resolve, then report the error to the HP Response Center or the nearest HP Support Office. When reporting the error, have the following information ready:

- Model and Serial Number of the printer.
- Which firmware revision the printer is using (See Note below). Check firmware in *Utilities / Statistics / Code rev.*
- The complete error number (See Note below).
- The Service Configuration Print.
- The Current configuration sheet.
- Which software application the customer is using (name, version, etc.).

When reporting the System Error Code, make sure that you supply the full Error Code and the firmware version. Without this information, HP Support Personnel cannot help you.

Performing a Service Test on a failed Assembly

If possible, always perform a Service Test on the component/assembly that you are about to replace, just to make sure that is the component/assembly that has failed.

If the test on that component/assembly passes, you should NOT replace it.

For information on the Service Tests and how to use them see Chapter 4, *Service Tests and Utilities*.

Performing the Necessary Service Calibrations

Is the printer calibrated correctly after replacing a component? For information on the Service Calibrations and how to use them see Chapter 5, *Service Calibrations*.

Remember that certain Calibrations are required even if an Assembly has been disassembled to gain access to another Assembly or Component.

Solving Print Quality Problems

Whenever a Print Quality problem appears, it is advisable to print the Diagnostic Print to help diagnose the problem. The Diagnostic Print will help you differentiate between possible printhead errors and other problems such as incorrect front-panel selection, driver or RIP configuration or mechanical problems. For information on solving Print Quality problems see Chapter 6, *Print Quality*.

The Printer does not Power ON

1. Check that the power cord is connected correctly to the Printer and to the Power Socket.
2. Check that the Power Switch on the BACK of the Printer is in the ON position.
3. Check to see the LED on the Front Panel Power Switch are On.
4. Check that the Front-Panel Cable is correctly connected to the Electronics Module. Also make sure that the Front-Panel cable is not damaged.
5. Replace the Power Supply Unit ⇒ Page 8-144.

The Printer Continuously Rejects Printheads

1. Clean the flex contacts on the Printhead and in the Carriage Assembly using the Carriage Interconnect Wiper (Refer to Chapter 3, *Ink Supplies Troubleshooting*.) and try again.
2. If ALL the Printheads are rejected (the status message on the Front Panel does NOT show "OK" for ALL the Printheads) then perform the Electronic Systems Test ⇒ Page 4-20.

Cover Sensors are not Working

1. Perform the Sensors Test ⇒ Page 4-31.
2. Check if the cable for the faulty sensor is not damaged and is connected correctly.
3. Replace the faulty Sensor.

The Line Sensor has Problems Detecting Media

1. Check the type of media that is being used since the Line sensor may have problems detecting transparent media or some types of Non-HP media. Try loading white HP media in to the Printer and check if the Line sensor detects it.
2. The Line Sensor is not calibrated correctly. Perform the Line Sensor Calibration ⇒ Page 5-14.
3. The Line Sensor is damaged or faulty. Replace the Line Sensor ⇒ Page 8-109.

Troubleshooting Media Jams/Printhead Crashes

The failure modes "media jam" and "head crash" are grouped together because in many cases a media jam causes the media to lift up into the Carriage path and cause a Printhead crash, thus causing many media jam failures to be reported as head crashes.

1. Did the media jam occur when loading media?

- If the client has had media jams, it is common for pieces of media to get stuck in the media path. Clear the media path.

When clearing a media jam, sometimes media is stuck in the paper path. To clear this, you must lift the Media Lever and insert thicker media into the paper path to push out the media that is still stuck there.

2. Is the customer using non-HP media?

- The use of non-HP media can easily be the cause of media jams and head crashes (especially head crashes because HP media is specially formulated to avoid cockle, one of the primary causes of head crashes). If the media is not HP approved, advise the customer to use HP media and check to see if the problem is now solved.

Banding at variable extreme environmental conditions

Since the Accuracy Calibration has been done at normal environmental conditions, printing in extreme environmental conditions will cause banding because the advance of the Drive Roller does not correspond to the same conditions that the calibration was done in. To solve the problem, try the following:

Perform the Accuracy Calibration in the new environmental conditions (Refer to the User's Guide).

Worm marks on HP Coated media with light area fills

Light bands (S-shaped) in Paper axis direction where light area fills are printed, causing unacceptable Image Quality defect.

- Print the Service Configuration Print and check if the level of Humidity is very low (below 30%). Increasing humidity may help in reducing the severity of the problem.

The media is causing the problem and NOT the Printer. Do not attempt to try and replace Printer parts to solve this problem.

Solving Media-Handling Problems

The Front Panel Keeps Indicating that Media Is Misaligned or Incorrectly Positioned

Roll media

- The roll may be loaded the wrong way. The paper should load over the roll toward you.
- Check that the paper is correctly loaded onto the spindle.
- The paper may be loaded at an angle. The right-hand edge must be aligned with the blue line on the Print Platen.

Ensure that the paper is wrapped tightly on the roll. This is a very important step to remember because if this is not done, the media may be loaded at an angle, causing the media to be rejected.

Sheet media

- It must be loaded with the right-hand edge against the blue line on the Print Platen.
- The media may be crumpled or warped or may have irregular edges.
- If hand-cut media is used, the edges may not form a right-angle or they may be rough. If possible, hand-cut media should not be used. Only purchased sheet media should be used in the Printer.
- If the overdrive is covered in dust, it will have problems picking up the sheet media during the load process. Clean the Overdrive using the Turn Drive Roller Service Utility ⇒ Page 4-59.

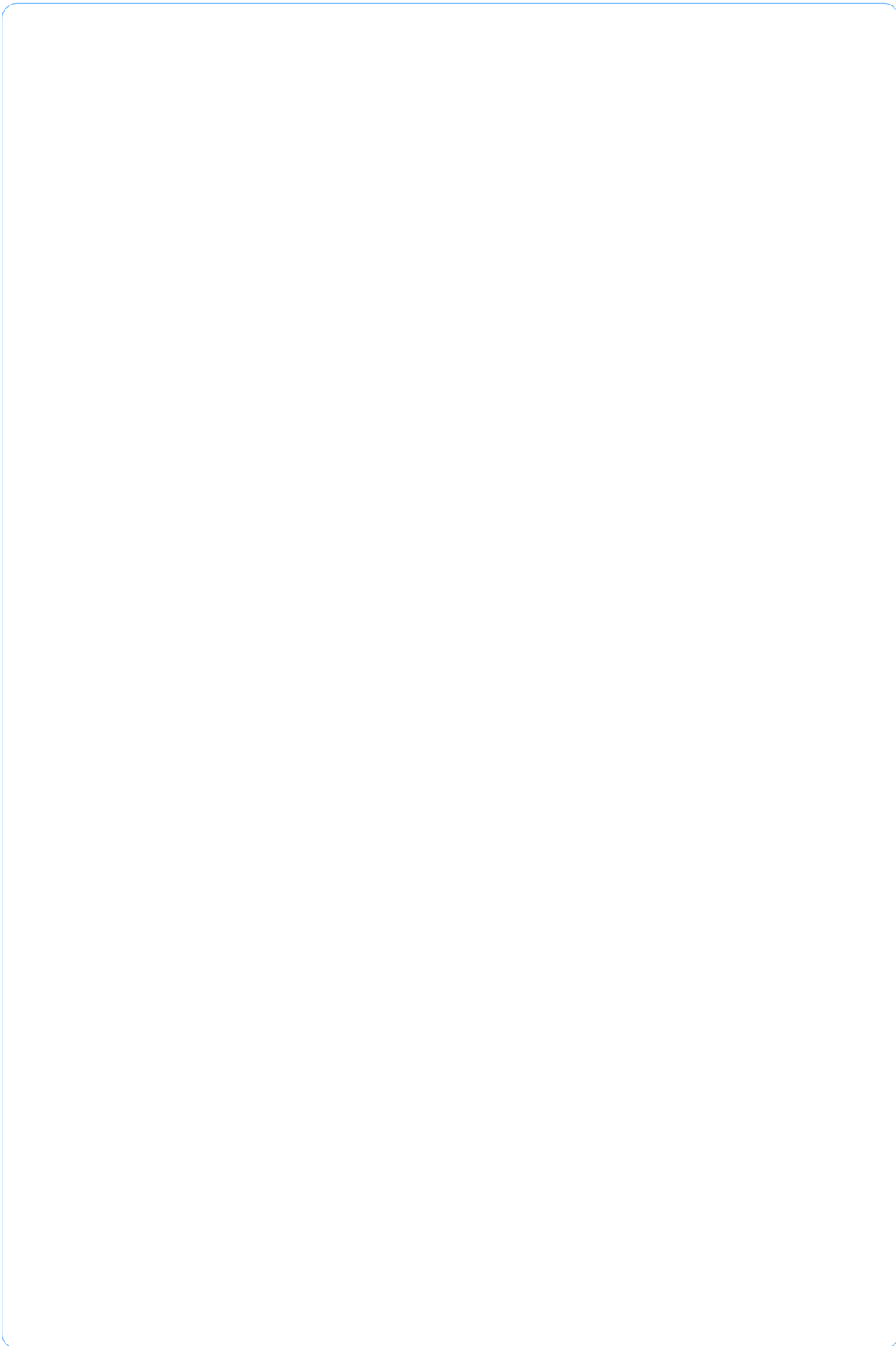



System Error Codes

2

Introduction	2-2
Continuable and Non-Continuable Error Codes	2-2
System Error Codes and Warnings - Explanation	2-3
System Error Codes and Warnings - Descriptions	2-6

Introduction

System error codes are hexa-decimal based numbers generally caused by internal system errors. The following pages contain a list of system error codes and their respective descriptions and recommended corrective actions. Only try one recommended action at a time and check if the error code has disappeared.

If you have an error code which is not documented in this Service Manual or you have an error which you cannot resolve, then report the error to the HP Response Center or the nearest HP Support Office. When reporting the error, have the following information ready:

- Model and Serial Number of the printer.
- Which firmware revision the printer is using (See Note below). Check firmware in *Setup Menu / Information Menu / Show Printer Information*.
- The complete error number (See Note below).
- The Service Configuration Print.
- The Current configuration sheet.
- Which software application the customer is using (name, version, etc.).

When reporting the System Error Code, make sure that you supply the full Internal Error Code and the firmware version. Without this information, HP Support Personnel cannot help you. To view the Internal Error Code, hold the UP key and press the CANCEL key at the same when the System Error.

Code is displayed on the Front Panel.

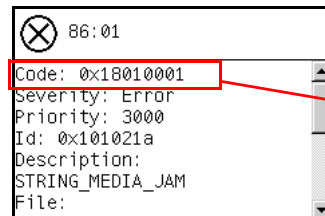

This is the Code that is required when escalating a problem

Continuable and Non-Continuable Error Codes

Some of the Error Codes are continuable, which means you can press **Enter** on the front-panel and continue working with the Printer. Non-Continuable Error Codes do not allow you to continue working with the Printer, in this case power the Printer OFF and ON again and see if the System Error

disappears. If the Error Code reappears, then the Printer requires an on-site visit in order to resolve the problem.

Even though the customer can continue working with a Continuable Error Code, an on-site visit should still be planned to troubleshoot the problem.

System Error Codes and Warnings - Explanation

System Error Codes explain which component/system is failing and what action should be taken to resolve the problem.

System Error Codes are displayed directly on the front panel (but can also be seen on the Information Page) and have been defined in the format **XX.YZ** or **XX.n:YZ.m**.

- **XX**: Service Part (2 digits).
- **n**: Service Part Index (if more than one used in the product) - Optional.
 - e.g. Identify the Ink Supply (color and number).
- **Y**: Who should perform the action (1 digit) - (0 for User or 1 for Service Engineer).
- **Z**: Action to perform (1 digit).
- **m**: additional actions/information to consider (1 digit) - Optional.
 - e.g. Non-authorized ink was detected, PM was triggered or Printhead in/out of Warranty.

The following table explains the **XX** part of the System Error Code or Warning:

Code	Component/System
01.0	Main PCA/Electronics module
01.1	Add-on Electronics module (printmech)
01.2	Print Mech PCA
01.3	Main PCA-Print Mech PCA
02.1	Carriage PCA
02.2	Carriage PCA
03	Power supply
05.1	Fan of the PSU/PCA Main
05.2	Main memory size failure.
06.1	Formatter
06.3	Formatter
07.1	Fan PSU
08	Front panel
11	Trailing cable
12.n	Carriage flex circuit n to pens
13.1	ISS Cable Left
13.2	ISS Cable Right

Code	Component/System
17	Harness Main to printmech
21.1	Service station
21.2	Service station
21.3	Service station
21.4	Primer
22.0	Bongo error BPS0 (ISS Left)
22.1	Bongo error BPS1 (ISS Left)
22.2	Bongo error BPS2 (ISS Right)
22.3	Bongo error BPS3 (ISS Right)
24	Tube assembly (IDS)
26.1	Supplies error
26.2	Supplies error
27	Printhead error
41	Paper-axis motor
42	Scan-axis motor
44	Aerosol fan
47	Star wheel motor
48	PPS mechanism
51	Window Sensor
52	Drop detector
52.1	Drop detector
52.2	Drop detector
53	Media Sensor
54	Media Lever Sensor
55	Line sensor
56	Drive roller analog encoder sensor
58	Color sensor (ESP)
58.1	Color sensor (ESP)
58.2	Color sensor (ESP)
58.3	Color sensor (ESP)
58.4	Color sensor (ESP)
61	Error job
63	Input/output through LAN card
64	Input/output through USB port
65	Input/output (not known what port)
66	Input/output (not known what port)
67	Input/output through FireWire port
71	Memory management
72	Firmware error
73	Servo
74	Part Number/Serial Number
75.1	Preventive Maintenance kit #1

Code	Component/System
75.2	Preventive Maintenance kit #2
75.3	Preventive Maintenance kit #3
79	Assertion (uncontrolled FW error)
81	Media advance
85	Media-axis encoder reading
86	Scan-axis encoder reading
87	Scan-axis encoder reading
94	Color calibration
94.1	Profiler
95	Printhead alignment
97	Paper advance calibration

The following table explains the **YZ** part of the System Error Code or Warning:

Code	Recovery Action	Response
00	Replace	Possible for customer to perform action
01	Reseat/Reconnect/Clean/Adjust (manually)	
02	Calibrate/Adjust (using Automatic Process)	
03	Power OFF and Restart the Printer	
04	Upgrade System Firmware	
05	Upgrade Driver or Computer Software	
06	Add Accessory	
07	Escalate	
08	Send Plot Again	
09	Wrong Part Installed	
10	Replace	hp qualified personnel assistance required
11	Reseat/Reconnect/Clean/Adjust (manually)	
12	Calibrate/Adjust (using Automatic Process)	
13	Power OFF	
14	Upgrade System Firmware	
15	Upgrade Driver or Computer Software	
16	Add Accessory	
17	Escalate	
18	Send Plot Again	
19	Wrong Part Installed	

System Error Codes and Warnings - Descriptions

This section describes each of the system error codes and warnings that could be encountered while using the printer and provides the remedial action required to solve the problem detected.

Only replace one component at a time and check if the error has gone before replacing another component. Using this procedure you will be able to determine exactly which component failed.

- System Error:** 01.0:YZ
Problem Description: HCl queue does not end after 2 seconds.
Corrective Action: Try the following:
- Switch the Power OFF from the back of the Printer and disconnect the Power cord. Reconnect the power cord and power On the Printer.
 - If the System Error continues, replace the Formatter ⇒ Page 8-140.
 - If the System Error continues, replace the Main PCA ⇒ Page 8-144.
- System Error:** 01.1:YZ
Problem Description: NVM backup: not found, read, write or read back error.
Corrective Action: Try the following:
- Switch the Power OFF from the back of the Printer and disconnect the Power cord. Reconnect the power cord and power On the Printer.
 - If the System Error continues, replace the Main PCA ⇒ Page 8-144.
 - If the System Error continues, replace the Formatter ⇒ Page 8-140.
- System Error:** 01.2:YZ
Problem Description: Print Mech PCA fault or NVM backup failure.
Corrective Action: Try the following:
- Switch the Power OFF from the back of the Printer and disconnect the Power cord. Reconnect the power cord and power On the Printer.
 - If the System Error continues, replace the PrintMech PCA ⇒ Page 8-61.

- System Error:** 01.3:YZ
Problem Description: Problem with the PrintMech PCA.
Corrective Action: Try the following:
- Switch the Power OFF from the back of the Printer and disconnect the Power cord. Reconnect the power cord and power On the Printer.
 - Check that the cables between the PrintMech PCA and Main PCA are not damaged and correctly connected.
 - If the System Error continues, replace the Main PCA ⇒ Page 8-144.
 - If the System Error continues, replace the Formatter ⇒ Page 8-140.
- System Error:** 02.1:YZ
Problem Description: Encoder seems to be wrong.
Corrective Action: Try the following:
- Switch the Power OFF from the back of the Printer and disconnect the Power cord. Reconnect the power cord and power On the Printer.
 - Check that the Carriage Assembly stopper is correctly installed.
 - Replace the Carriage Assembly ⇒ Page 8-85.
 - If the System Error continues, replace the Encoder Strip ⇒ Page 8-74 and Encoder Sensor ⇒ Page 8-152.
- System Error:** 02.2:YZ
Problem Description: Problem with the Carriage PCA.
Corrective Action: Try the following:
- Switch the Power OFF from the back of the Printer and disconnect the Power cord. Reconnect the power cord and power On the Printer.
 - Check that the Trailing Cable is not damaged.
 - Check that the Trailing Cable is correctly connected between the Main PCA and Carriage PCA.
 - Replace the Carriage Assembly ⇒ Page 8-85.
 - If the System Error continues, replace the Formatter ⇒ Page 8-140.

System Error:	03:YZ
Problem Description:	Problem with Power Supply Unit.
Corrective Action:	Try the following: <ul style="list-style-type: none">■ Switch the Power OFF from the back of the Printer and disconnect the Power cord. Reconnect the power cord and power On the Printer.■ Perform the Electronics Module Test Diagnostic to troubleshoot the problem further ⇒ Page 4-20.■ If the System Error continues, replace the Power Supply Unit (PSU) ⇒ Page 8-144.
System Error:	05.1:YZ
Problem Description:	CPU Fan is stopped or burnt.
Corrective Action:	Try the following: <ul style="list-style-type: none">■ Switch the Power OFF from the back of the Printer and disconnect the Power cord. Reconnect the power cord and power On the Printer.■ Replace the Power Supply Unit (PSU) ⇒ Page 8-144.■ If the System Error continues, replace the Main PCA ⇒ Page 8-144.
System Error:	05:2:YZ
Problem Description:	Main memory size failure.
Corrective Action:	Try the following: <ul style="list-style-type: none">■ Switch the Power OFF from the back of the Printer and disconnect the Power cord. Reconnect the power cord and power On the Printer.■ Check that correct size of memory (128 or 256 MB) is installed in the Formatter.■ Check that the Memory Module is installed correctly.■ If the System Error continues, replace the Formatter ⇒ Page 8-140.■ If the System Error reappears, replace the Main PCA ⇒ Page 8-144.
System Error:	06.1:YZ
Problem Description:	Main NVM failure - not detected, read/write failed or readback error.
Corrective Action:	Try the following: <ul style="list-style-type: none">■ Switch the Power OFF from the back of the Printer and disconnect the Power cord. Reconnect the power cord and power On the Printer.■ If the System Error continues, replace the Formatter ⇒ Page 8-140.

- System Error:** 06.2:YZ
Problem Description: NVM main: not detected, read, write or read back error (HDD error).
Corrective Action: Try the following:
- Switch the Power OFF from the back of the Printer and disconnect the Power cord. Reconnect the power cord and power On the Printer.
 - If the System Error continues, replace the Formatter ⇒ Page 8-140.
- System Error:** 06.3:YZ
Problem Description: NVM main: not found, read, write or read back error (HDD error).
Corrective Action: Try the following:
- Switch the Power OFF from the back of the Printer and disconnect the Power cord. Reconnect the power cord and power On the Printer.
 - If the System Error continues, replace the Formatter ⇒ Page 8-140.
- System Error:** 07.1:YZ
Problem Description: Fan PSU driver burnt.
Corrective Action: Try the following:
- Switch the Power OFF from the back of the Printer and disconnect the Power cord. Reconnect the power cord and power On the Printer.
 - If the System Error continues, replace the Main PCA ⇒ Page 8-144.
 - If the System Error continues, replace the Formatter ⇒ Page 8-140.
- System Error:** 08:YZ
Problem Description: Problem with the Front Panel.
Corrective Action: Try the following:
- Switch the Power OFF from the back of the Printer and disconnect the Power cord. Reconnect the power cord and power On the Printer.
 - Check that the Front Panel interface cable is not damaged and is correctly connected between the Main PCA and the Front Panel.
 - Check that the memory module in the Formatter is installed correctly.
 - Check that the connections between the Formatter, the Formatter and the Formatter are not damaged and are correctly connected.
 - Check that the Printer has the latest Firmware version. If not, update the Firmware to the latest version.
 - If the System Error continues, replace the Main PCA ⇒ Page 8-144.
 - If the System Error continues, replace the Formatter ⇒ Page 8-140.
 - If the System Error continues, replace the Front Panel ⇒ Page 8-40.

System Error: 11:YZ

Problem Description: Trailing Cable does not seem to be detected.

Corrective Action: Try the following:

- Switch the Power OFF from the back of the Printer and disconnect the Power cord. Reconnect the power cord and power On the Printer.
- Check that the Trailing Cable is not damaged.
- Check that the Trailing Cable is correctly connected between the Main PCA and Carriage PCA.
- If the System Error continues, replace the Formatter ⇒ Page 8-140.
- If the System Error continues, replace the Main PCA ⇒ Page 8-144.
- If the System Error continues, replace the Carriage PCA ⇒ Page 8-119.

System Error: 12.n:YZ

Problem Description: Carriage & PCA Main doesn't detect pens.

Corrective Action: Try the following:

- Switch the Power OFF from the back of the Printer and disconnect the Power cord. Reconnect the power cord and power On the Printer.
- Check that the Trailing Cable is not damaged.
- Check that the Trailing Cable is correctly connected between the Main PCA and Carriage PCA.
- Check that the Printhead has not failed and is not erroneous.
- Check that the Flex circuit contacts and Printhead contacts are clean.
- If the System Error continues, replace the Carriage PCA ⇒ Page 8-119.
- If the System Error continues, replace the Main PCA ⇒ Page 8-144.

System Error: 13.1:YZ

Problem Description: The ISS Left cable may be not properly connected or malfunctioning.

Corrective Action: Try the following:

- Switch the Power OFF from the back of the Printer and disconnect the Power cord. Reconnect the power cord and power On the Printer.
- Remove ALL the cartridges from the Left Ink Supply Station and reinstall them in the printer.
- Check that the cables between the Left Ink Supply Station and Main PCA the are not damaged and are correctly connected.
- If the System Error continues, replace the Left Ink Supply Station ⇒ Page 8-128.
- If the System Error continues, replace the Main PCA ⇒ Page 8-144.

- System Error:** 13.2:YZ
- Problem Description:** The ISS Right cable may be not properly connected or malfunctioning.
- Corrective Action:** Try the following:
- Switch the Power OFF from the back of the Printer and disconnect the Power cord. Reconnect the power cord and power On the Printer.
 - Remove ALL the cartridges from the Right Ink Supply Station and reinstall them in the printer.
 - Check that the cables between the Right Ink Supply Station and Main PCA are not damaged and are correctly connected.
 - If the System Error continues, replace the Right Ink Supply Station ⇒ Page 8-124.
 - If the System Error continues, replace the Main PCA ⇒ Page 8-144.
- System Error:** 17:YZ
- Problem Description:** The harness main of PCA Main to Printmech may be not properly connected or malfunctioning.
- Corrective Action:** Try the following:
- Switch the Power OFF from the back of the Printer and disconnect the Power cord. Reconnect the power cord and power On the Printer.
 - Check the interconnection cables between the Main PCA and PrintMech PCA are not damaged and are correctly connected.
 - replace the Harness Main?????
 - If the System Error continues, replace the Main PCA ⇒ Page 8-144.
 - If the System Error continues, replace the PrintMech PCA ⇒ Page 8-61.
- System Error:** 21.1:YZ
- Problem Description:** Service Station servo shutdown.
- Corrective Action:** Try the following:
- Switch the Power OFF from the back of the Printer and disconnect the Power cord. Check the Primer Tubes. Reconnect the power cord and power On the Printer.
 - Perform the Service Station diagnostic test to troubleshoot the problem further ⇒ Page 4-41.
 - If the System Error continues, replace the Service Station ⇒ Page 8-51.
 - If the System Error continues, replace the PrintMech PCA ⇒ Page 8-61.

System Error:	21.2:YZ
Problem Description:	Fail moving Service Station.
Corrective Action:	Try the following: <ul style="list-style-type: none">■ Switch the Power OFF from the back of the Printer and disconnect the Power cord. Check the Primer Tubes. Reconnect the power cord and power On the Printer.■ Make sure that the Service Station path is clear. Remove any visible obstacles (e.g. screws, plastic parts, etc...) restricting the movement of the Service Station.■ Perform the Service Station diagnostic test to troubleshoot the problem further ⇒ Page 4-41.■ If the System Error continues, replace the Service Station ⇒ Page 8-51.■ If the System Error continues, replace the PrintMech PCA ⇒ Page 8-61.
System Error:	21.3:YZ
Problem Description:	Problem with the Service Station.
Corrective Action:	Try the following: <ul style="list-style-type: none">■ Switch the Power OFF from the back of the Printer and disconnect the Power cord. Check the Primer Tubes. Reconnect the power cord and power On the Printer.■ Make sure that the Service Station path is clear. Remove any visible obstacles (e.g. screws, plastic parts, etc...) restricting the movement of the Service Station.■ Perform the Service Station diagnostic test to troubleshoot the problem further ⇒ Page 4-41.■ If the System Error continues, replace the Service Station ⇒ Page 8-51.■ If the System Error continues, replace the PrintMech PCA ⇒ Page 8-61.
System Error:	21.4:YZ
Problem Description:	Primer error (Primer motor: zero not found, Servo Shutdown, Servo Warm, and Servo Fault).
Corrective Action:	Try the following: <ul style="list-style-type: none">■ Switch the Power OFF from the back of the Printer and disconnect the Power cord. Check the Primer Tubes. Reconnect the power cord and power On the Printer.■ Perform the Service Station diagnostic test to troubleshoot the problem further ⇒ Page 4-41.■ If the System Error continues, replace the Service Station ⇒ Page 8-51.■ If the System Error continues, replace the PrintMech PCA ⇒ Page 8-61.

System Error: 22.0:YZ
Problem Description: ISS Left BPS0 error.(Supplies 0, 1, 2).
Corrective Action: Try the following:

- Switch the Power OFF from the back of the Printer and disconnect the Power cord. Reconnect the power cord and power On the Printer.
- Check that the cables between the Left Ink Supply Station and Main PCA the are not damaged and are correctly connected.
- Perform the Ink Supply Station Supplies diagnostic test to troubleshoot the problem further ⇒ Page 4-37.
- If the System Error continues, replace the Left Ink Supply Station ⇒ Page 8-128.
- If the System Error continues, replace the Main PCA ⇒ Page 8-144.
- If the System Error continues, replace the Formatter ⇒ Page 8-140.

System Error: 22.1:YZ
Problem Description: ISS Left BPS1 error.(Supplies 3, 4, 5).
Corrective Action: Try the following:

- Switch the Power OFF from the back of the Printer and disconnect the Power cord. Reconnect the power cord and power On the Printer.
- Check that the cables between the Left Ink Supply Station and Main PCA the are not damaged and are correctly connected.
- Perform the Ink Supply Station Supplies diagnostic test to troubleshoot the problem furtherPage 4-37.
- If the System Error continues, replace the Left Ink Supply Station ⇒ Page 8-128.
- If the System Error continues, replace the Main PCA ⇒ Page 8-144.
- If the System Error continues, replace the Formatter ⇒ Page 8-140.

System Error: 22.2:YZ
Problem Description: ISS Right BPS0 error.(Supplies 6, 7, 8).
Corrective Action: Try the following:

- Switch the Power OFF from the back of the Printer and disconnect the Power cord. Reconnect the power cord and power On the Printer.
- Check that the cables between the Right Ink Supply Station and PrintMech PCA the are not damaged and are correctly connected.
- Perform the Ink Supply Station Supplies diagnostic test to troubleshoot the problem further ⇒ Page 4-37.
- If the System Error continues, replace the Right Ink Supply Station ⇒ Page 8-128.
- If the System Error continues, replace the Main PCA ⇒ Page 8-144.
- If the System Error continues, replace the Formatter ⇒ Page 8-140.

System Error:	22.3:YZ
Problem Description:	ISS Right BPS1 error.(Supplies 9, 10, 11).
Corrective Action:	Try the following: <ul style="list-style-type: none">■ Switch the Power OFF from the back of the Printer and disconnect the Power cord. Reconnect the power cord and power On the Printer.■ Check that the cables between the Right Ink Supply Station and PrintMech PCA the are not damaged and are correctly connected.■ Perform the Ink Supply Station Supplies diagnostic test to troubleshoot the problem further ⇒ Page 4-37.■ If the System Error continues, replace the Right Ink Supply Station ⇒ Page 8-128.■ If the System Error continues, replace the Main PCA ⇒ Page 8-144.■ If the System Error continues, replace the Formatter ⇒ Page 8-140.
System Error:	24:YZ
Problem Description:	Ink Setup failure(Ink Delivery System (IDS) Tubes purge failed).
Corrective Action:	Try the following: <ul style="list-style-type: none">■ Switch the Power OFF from the back of the Printer and disconnect the Power cord. Reconnect the power cord and power On the Printer.■ Try purging the Ink Supply Tubes again once the Printer has been restarted.■ Install new Cartridges in the printer and try purging the Ink Supply Tubes again.
System Error:	26.1:YZ
Problem Description:	Order of Ink Supplies incorrect.
Corrective Action:	Try the following: <ul style="list-style-type: none">■ Remove the Ink Supply Cartridges and check that they are the correct ones for this printer.■ Check that the Printer has the latest firmware. If not, update the firmware to the latest version.

- System Error:** 26.2:YZ
Problem Description: A wrong Ink Cartridge has been detected.
Corrective Action: Try the following:
- Remove the Ink Supply Cartridges and check that they are the correct ones for this printer.
 - Check that the Printer has the latest firmware. If not, update the firmware to the latest version.
 - Replace the Ink Supply Cartridges.
- System Error:** 27:YZ
Problem Description: An error has occurred in Printhead detection.
Corrective Action: Try the following:
- Switch the Power OFF from the back of the Printer and disconnect the Power cord. Reconnect the power cord and power On the Printer.
 - Remove the Printheads from the Carriage Assembly and reinsert them.
 - Replace the Printheads.
 - Replace the Carriage Cover (Flex Circuit) ⇒ Page 8-114.
 - Replace the Carriage PCA ⇒ Page 8-119.
 - Replace the Formatter ⇒ Page 8-140.
- System Error:** 41:YZ
Problem Description: Electrical fault or current limit in Media-Axis Motor..
Corrective Action: Try the following:
- Switch the Power OFF from the back of the Printer and disconnect the Power cord. Reconnect the power cord and power On the Printer.
 - Open the Window and check for any visible obstacles restricting the movement of the Media Advance Roller. If there is a wrinkled mass of media inside the paper path, lift the Pinch wheels (using Media Lever) and clear the obstruction.
 - Perform the Media Drive diagnostic test to troubleshoot the problem further ⇒ Page 4-16.
 - Check that the Media Advance Drive cable is not damaged and is correctly connected to the Main PCA.
 - Replace the Media Advance Drive ⇒ Page 8-155.
 - If the System Error continues, replace the Main PCA ⇒ Page 8-144.

System Error:	42:YZ
Problem Description:	Electrical fault or current limit in Scan-Axis Motor..
Corrective Action:	Try the following: <ul style="list-style-type: none">■ Switch the Power OFF from the back of the Printer and disconnect the Power cord. Reconnect the power cord and power On the Printer.■ Open the Window and check for any visible obstacles restricting the movement of the Media Advance Roller. If there is a wrinkled mass of media inside the paper path, lift the Pinch wheels (using Media Lever) and clear the obstruction.■ Perform the Scan Axis diagnostic test to troubleshoot the problem further ⇒ Page 4-6.■ Check that the Scan-Axis Motor cable is not damaged and is correctly connected to the PrintMech PCA.■ Replace the Scan-Axis Motor ⇒ Page 8-97.■ If the System Error continues, replace the PrintMech PCA ⇒ Page 8-61.
System Error:	44:YZ
Problem Description:	Fan Electrical fault, or not connected..
Corrective Action:	Try the following: <ul style="list-style-type: none">■ Switch the Power OFF from the back of the Printer and disconnect the Power cord. Reconnect the power cord and power On the Printer.■ Check that the Aerosol Fan cable is not damaged and is correctly connected to the PrintMech PCA■ Replace the Aerosol Fan Assembly ⇒ Page 8-56.■ If the System Error continues, replace the PrintMech PCA ⇒ Page 8-61.
System Error:	47:YZ
Problem Description:	Star wheels motor error..
Corrective Action:	Try the following: <ul style="list-style-type: none">■ Switch the Power OFF from the back of the Printer and disconnect the Power cord. Reconnect the power cord and power On the Printer.■ Check that the Starwheel Assembly cable is not damaged and is correctly connected to Main PCA.■ Open the Window and check for any visible obstacles restricting the movement of the Starwheel Assembly, then clear the obstruction.■ Perform the Scan Axis Starwheel diagnostic test to troubleshoot the problem further ⇒ Page 4-6.■ Replace the Starwheel Motor ⇒ Page 8-176.■ If the System Error continues, replace the Main PCA ⇒ Page 8-144.

- System Error:** 48:YZ
Problem Description: PPS system failure.
Corrective Action: Try the following:
- Switch the Power OFF from the back of the Printer and disconnect the Power cord. Reconnect the power cord and power On the Printer.
 - Check that the Pen to Paper Space (PPS) Solenoid cable is not damaged and is correctly connected to the PrintMech PCA.
 - Perform the Scan Axis PSS diagnostic test to troubleshoot the problem further ⇒ Page 4-6.
 - Replace the Pen to Paper Space (PPS) Solenoid ⇒ Page 8-63.
 - If the System Error continues, replace the PrintMech PCA ⇒ Page 8-61.
- System Error:** 51:YZ
Problem Description: Window Sensor failure.
Corrective Action: Try the following:
- Check that the Window Position Sensor cable is not damaged and is correctly connected to the PrintMech PCA.
 - Perform the Sensors Test to troubleshoot the problem further ⇒ Page 4-31.
 - Replace the Window Position Sensor ⇒ Page 8-45.
- System Error:** 52:YZ
Problem Description: The printer has detected a faulty pare in Drop Detector (DDP)..
Corrective Action: Try the following:
- Switch the Power OFF from the back of the Printer and disconnect the Power cord. Reconnect the power cord and power On the Printer.
 - Check that the Drop Detector cable is not damaged and is correctly connected to the PrintMech PCA.
 - Check that the Service Station cable is not damaged and is correctly connected to the PrintMech PCA.
 - Replace the Drop Detector ⇒ Page 8-55.
 - Reset the Calibration of the Drop Detector ⇒ Page 4-6.
 - Calibrate the Drop Detector ⇒ Page 5-12.
 - If the System Error continues, replace the PrintMech PCA ⇒ Page 8-61.
 - If the System Error continues, replace the Formatter ⇒ Page 8-140.

System Error:	52.1:YZ
Problem Description:	Failure to switch ON Drop Detector (DDP)..
Corrective Action:	Try the following: <ul style="list-style-type: none">■ Switch the Power OFF from the back of the Printer and disconnect the Power cord. Reconnect the power cord and power On the Printer.■ Check that the Drop Detector cable is not damaged and is correctly connected to the PrintMech PCA.■ Check that the Service Station cable is not damaged and is correctly connected to the PrintMech PCA.■ Replace the Drop Detector ⇒ Page 8-55.■ Reset the Calibration of the Drop Detector Page 5-12.■ Calibrate the Drop Detector Page 5-12.■ If the System Error continues, replace the PrintMech PCA ⇒ Page 8-61.■ If the System Error continues, replace the Formatter ⇒ Page 8-140.
system Error:	52.2:YZ
Problem Description:	Failure to switch OFF Drop Detector (DDP)..
Corrective Action:	Try the following: <ul style="list-style-type: none">■ Switch the Power OFF from the back of the Printer and disconnect the Power cord. Reconnect the power cord and power On the Printer.■ Check that the Drop Detector cable is not damaged and is correctly connected to the PrintMech PCA.■ Check that the Service Station cable is not damaged and is correctly connected to the PrintMech PCA.■ Replace the Drop Detector ⇒ Page 8-55.■ Reset the Calibration of the ⇒ Drop Detector Page 5-12.■ Calibrate the Drop Detector ⇒ Page 5-12.■ If the System Error continues, replace the PrintMech PCA ⇒ Page 8-61.■ If the System Error continues, replace the Formatter ⇒ Page 8-140.
System Error:	53:YZ
Problem Description:	An error with the Main Media Sensor has been detected.
Corrective Action:	Try the following: <ul style="list-style-type: none">■ Check that the Out Of Paper Sensor cable is not damaged and is connected correctly to the PrintMech PCA.■ Perform the Sensors Test to troubleshoot the problem further ⇒ Page 4-31.■ Replace the Out Of Paper Sensor ⇒ Page 8-69.

- System Error:** 54:YZ
Problem Description: An error with the Pinch Lever sensor has been detected.
Corrective Action: Try the following:
- Check that the Media Lever Position Sensor cable is not damaged and is connected correctly to the Main PCA.
 - Replace the Media Lever Position Sensor ⇒ Page 8-33.
- System Error:** 55:YZ
Problem Description: Problem with the Line Sensor (Tetris). The printer has detected a failure to access Line Sensor EEPROM).
Corrective Action: Try the following:
- Switch the Power OFF from the back of the Printer and disconnect the Power cord. Reconnect the power cord and power On the Printer.
 - Perform the Carriage Test to troubleshoot the problem further ⇒ Page 4-25
 - Check the Line Sensor connections to the Carriage PCA.
 - Replace the Line Sensor ⇒ Page 8-109.
 - If the System Error continues, replace the Carriage PCA ⇒ Page 8-119.
- System Error:** 56:YZ
Problem Description: Drive roller analog encoder sensor fail or calibration failed.
Corrective Action: Try the following:
- Switch the Power OFF from the back of the Printer and disconnect the Power cord. Reconnect the power cord and power On the Printer.
 - Perform the Media Path Test to troubleshoot the problem further ⇒ Page 4-16.
 - Replace the Encoder Disk and Encoder Sensor ⇒ Page 8-152.
 - If the System Error continues, replace the Main PCA ⇒ Page 8-144.
- System Error:** 58:YZ
Problem Description: The Color Sensor (Spectrophotometer-ESP) of the printer is not working well.
Corrective Action: Try the following:
- Switch the Power OFF from the back of the Printer and disconnect the Power cord. Reconnect the power cord and power On the Printer.
 - The Color Sensor (ESP) shutter has not opened.
 - Perform the Carriage Test to troubleshoot the problem further ⇒ Page 4-25.
 - If the System Error continues, replace the Color Sensor (ESP) ⇒ Page 8-103.
 - If the System Error continues, replace the Carriage PCA ⇒ Page 8-119.

- System Error:** 58.1:YZ
- Problem Description:** The Color Sensor (Spectrophotometer-ESP-) of the printer is not working well. Failure to communicate with Color Sensor.
- Corrective Action:** Try the following:
- Switch the Power OFF from the back of the Printer and disconnect the Power cord. Reconnect the power cord and power On the Printer.
 - Perform the Carriage Test to troubleshoot the problem further ⇒ Page 4-25.
 - If the System Error continues, replace the Color Sensor (ESP) ⇒ Page 8-103.
 - If the System Error continues, replace the Carriage PCA ⇒ Page 8-119.
 - If the System Error continues, replace the Formatter ⇒ Page 8-140.
- System Error:** 58.2:YZ
- Problem Description:** The Color Sensor (Spectrophotometer-ESP-) of the printer is not working well. Failure in self test of the Color Sensor.
- Corrective Action:** Try the following:
- Switch the Power OFF from the back of the Printer and disconnect the Power cord. Reconnect the power cord and power On the Printer.
 - Perform the Carriage Test to troubleshoot the problem further ⇒ Page 4-25.
 - If the System Error continues, replace the Color Sensor (ESP) ⇒ Page 8-103.
 - If the System Error continues, replace the Carriage PCA ⇒ Page 8-119.
 - If the System Error continues, replace the Formatter ⇒ Page 8-140.
- System Error:** 58.3:YZ
- Problem Description:** The Color Sensor (Spectrophotometer-ESP-) of the printer is not working well. Failure in Calibrating the Color Sensor.
- Corrective Action:** Try the following:
- Switch the Power OFF from the back of the Printer and disconnect the Power cord. Reconnect the power cord and power On the Printer.
 - Perform the Carriage Test to troubleshoot the problem furtherPage 4-25.
 - If the System Error continues, replace the Color Sensor (ESP) ⇒ Page 8-103.
 - If the System Error continues, replace the Carriage PCA ⇒ Page 8-119.
 - If the System Error continues, replace the Formatter ⇒ Page 8-140.

- System Error:** 58.4:YZ
- Problem Description:** The Color Sensor (Spectrophotometer-ESP) of the Printer is not working well. The firmware version of the Color Sensor is incompatible with the Printer.
- Corrective Action:** Try the following:
- Switch the Power OFF from the back of the Printer and disconnect the Power cord. Reconnect the power cord and power On the Printer.
 - Perform the Carriage Test to troubleshoot the problem further ⇒ Page 4-25.
 - Check that the Printer has the latest Firmware version. If not, update the Firmware to the latest version.
 - If the System Error continues, replace the Color Sensor (ESP) ⇒ Page 8-103.
 - If the System Error continues, replace the Formatter ⇒ Page 8-140.
- System Error:** 61:YZ
- Problem Description:** The file format is incorrect and the Printer cannot process the job.
- Corrective Action:** Try the following:
- Switch the Power OFF from the back of the Printer and disconnect the Power cord. Reconnect the power cord and power On the Printer.
 - Check the graphic language setting of the Printer (Refer to the User's Guide).
 - Resend the file to the printer.
 - Check that the Printer has the latest Firmware version. If not, update the Firmware to the latest version.
 - The Postscript fonts are missing. Upgrading the Firmware will re-install the fonts.
 - The file cannot be printed because it is password protected. Resend the file without password protection.
- System Error:** 63:YZ
- Problem Description:** Input/Output problem through the Network Card.
- Corrective Action:** Try the following:
- Switch the Power OFF from the back of the Printer and disconnect the Power cord. Reconnect the power cord and power On the Printer.
 - Check that the Network cable is correctly connected to the Formatter.
 - Check that the Printer has the latest Firmware version. If not, update the Firmware to the latest version.
 - If the System Error continues, replace the Formatter ⇒ Page 8-140.
 - If the System Error continues, replace the Main PCA ⇒ Page 8-144.

System Error:	64:YZ
Problem Description:	Input/Output problem through the USB Port.
Corrective Action:	Try the following: <ul style="list-style-type: none">■ Switch the Power OFF from the back of the Printer and disconnect the Power cord. Reconnect the power cord and power On the Printer.■ Check that the USB cable is correctly connected to the Printer.■ Check that the Printer has the latest Firmware version. If not, update the Firmware to the latest version.■ If the System Error continues, replace the Formatter ⇒ Page 8-140.■ If the System Error continues, replace the Main PCA ⇒ Page 8-144.
System Error:	65:YZ
Problem Description:	Memory Driver Internal I/O error, I/O Socket Manager Internal I/O error.
Corrective Action:	Try the following: <ul style="list-style-type: none">■ Switch the Power OFF from the back of the Printer and disconnect the Power cord. Reconnect the power cord and power On the Printer.■ Check that the unknown port cable is correctly connected to the Printer.■ Check that the Printer has the latest Firmware version. If not, update the Firmware to the latest version.■ If the System Error continues, replace the Formatter ⇒ Page 8-140.■ If the System Error continues, replace the Main PCA ⇒ Page 8-144.
System Error:	66:YZ
Problem Description:	Cannot print file on current paper type. The paper type has changed since the file was sent, so the file cannot be printed on the paper type currently loaded.
Corrective Action:	Try the following: <ul style="list-style-type: none">■ Resend the file to be printed on the current paper type.■ Change the paper type to the type that was loaded when the file was originally sent.
System Error:	67:YZ
Problem Description:	Input/Output problem through a Firewire Port.
Corrective Action:	Try the following: <ul style="list-style-type: none">■ Check that the firewire cable is correctly connected to the Printer.■ Check that the Printer has the latest Firmware version. If not, update the Firmware to the latest version.■ If the System Error continues, replace the Main PCA ⇒ Page 8-144.

System Error: 71:YZ
Problem Description: Out of memory failure.
Corrective Action: Try the following:
■ It is recommended that you remove any unnecessary files from the Hard Disk Drive of the Formatter using the Web Server.

System Error: 71:19
Problem Description: Default Serial Number found in the main and backup NVM. It seems that both the Print Mech PCA and Hard Disk Drive have been replaced together.
Corrective Action: Try the following:
■ Perform the “Error 71:19 Recovery” Service Utility ⇒ Page 4-52.

You MUST NEVER replace both the Formatter and the PrintMech PCA at the same time. If both parts need to be replaced, you MUST first replace one part and then power ON the Printer until it completely initializes. Then you can power OFF the Printer and replace the other part.

System Error: 72:YZ
Problem Description: Generic Firmware error.
Corrective Action: Try the following:
■ Switch the Power OFF from the back of the Printer and disconnect the Power cord. Reconnect the power cord and power On the Printer.
■ Check that the Printer has the latest Firmware version. If not, update the Firmware to the latest version.

System Error: 73:YZ
Problem Description: Servo Error.
Corrective Action: Try the following:
■ Switch the Power OFF from the back of the Printer and disconnect the Power cord. Reconnect the power cord and power On the Printer.
■ Check that the Printer has the latest Firmware version. If not, update the Firmware to the latest version.
■ Perform the Scan Axis Test to troubleshoot the problem further ⇒ Page 4-6.
■ If the System Error continues, perform the Media Drive diagnostic test to troubleshoot the problem further ⇒ Page 4-16.

System Error: 74:YZ
Problem Description: Failed getting Part Number/Serial Number.
Corrective Action: Try the following:

- Switch the Power OFF from the back of the Printer and disconnect the Power cord. Reconnect the power cord and power On the Printer.
- Check that the Printer has the latest Firmware version. If not, update the Firmware to the latest version.
- Use the Service Menu to update the S/N or Part Number ⇒ Page 4-49.

System Error: 75.1:YZ
Problem Description: Preventive Maintenance Kit #1 counter active.
Corrective Action: Try the following:

- Switch the Power OFF from the back of the Printer and disconnect the Power cord.
- Change the Left Spittoon foams and the Service Station foams. You should use the Service parts:
PM Kit #1 Q5669-60720.
Once the parts have been changed, use the Service Menu to reset the counters that affect PMKit #1.

System Error: 75.2:YZ
Problem Description: Preventive Maintenance Kit #2 counter active.
Corrective Action: Try the following:

- Switch the Power OFF from the back of the Printer and disconnect the Power cord.
- Change the Left Spittoon foams and Belt Assembly, the Scan-Axis Motor, the Ink Supply Tubes, and Carriage Assembly (this does not include the Carriage PCA and Color Sensor (ESP), but it does include the Trailing Cable).
You should use the Service parts:
PMKit #2 Q6675-60032 Z2100 (24 inch)
PMKit #2 Q6677-60015 Z2100 (44 inch)
PMKit #2 Q5669-60748 Z3100 (24 inch)
PMKit #2 Q6659-60189 Z3100 (44 inch)
Once the parts have been changed, use the Service Menu to reset the counters that affect PMKit #2.

- System Error:** 75.3:YZ
Problem Description: Preventive Maintenance Kit #3 counter active.
Corrective Action: Try the following:
- Switch the Power OFF from the back of the Printer and disconnect the Power cord.
 - Change the Cutter Assembly (User replaceable). You should use the Service parts PMKit #3 Q5669-60722.
 - Once the parts have been changed, use the Service Menu to reset the counters that affect PMKit #3.
- System Error:** 79:YZ
Problem Description: Generic Firmware error.
Corrective Action: Try the following:
- Switch the Power OFF from the back of the Printer and disconnect the Power cord. Reconnect the power cord and power On the Printer.
 - Check that the Printer has the latest Firmware version. If not, update the Firmware to the latest version.
- System Error:** 81:YZ
Problem Description: Paper servo shutdown.
Corrective Action: Try the following:
- Open the Window and check for any visible obstacles restricting the movement of the Drive Roller. If there is a wrinkled mass of media inside the paper path, lift the Pinchwheels (using the Media Lever) and clear the obstruction.
 - Perform the Media Drive diagnostic test to troubleshoot the problem further ⇒ Page 4-16.
 - Check the connections on the Main PCA; the Media Advance Drive is connected to the connector labeled Paper Motor
 - If the System Error continues, replace the Media Advance Driver ⇒ Page 8-155.
- System Error:** 85:YZ
Problem Description: Problem finding the Drive Roller zero.
Corrective Action: Try the following:
- Perform the Media Drive diagnostic test to troubleshoot the problem further ⇒ Page 4-16.

System Error: 86:YZ
Problem Description: Possible Paper Jam.
Corrective Action: Try the following:

- Switch the Power OFF from the back of the Printer and disconnect the Power cord. Reconnect the power cord and power On the Printer.
- Open the Window and check for any visible obstacles restricting the movement of the Drive Roller. If there is a wrinkled mass of media inside the paper path, lift the Pinch wheels (using the Media Lever) and clear the obstruction.

System Error: 87:YZ
Problem Description: Problem finding the Scan-axis encoder reading.
Corrective Action: Try the following:

- Switch the Power OFF from the back of the Printer and disconnect the Power cord. Reconnect the power cord and power On the Printer.
- Movement jam.
- Possible paper jam.
- Mechanical Initiator scan axis measure error.
- Check that the Scan-Axis Motor is correctly connected.
- Check that the Encoder Sensor is correctly connected.
- Perform the Scan Axis diagnostic test to troubleshoot the problem further ⇒ Page 4-6

System Error: 94:YZ
Problem Description: Color calibration Error.
Corrective Action: Try the following:

- Profiling failed due to a different error (not algorithm / data processing).
- Perform the Color Sensor (ESP) calibration. You must use glossy paper for this calibration.
- If the System Error continues, replace the Carriage PCA ⇒ Page 8-119.
- If the System Error continues, replace the Formatter ⇒ Page 8-140.

- System Error:** 94.1:YZ
Problem Description: Profiling algorithm failed.
Try the following:
- Profiling failed due to a different error (not algorithm / data processing).
 - Perform the Color Sensor (ESP) calibration. You must use glossy paper for this calibration.
 - If the System Error continues, replace the Carriage PCA ⇒ Page 8-119.
 - If the System Error continues, replace the Formatter ⇒ Page 8-140.
- System Error:** 95:YZ
Problem Description: The Calibration of the Paper advance doesn't activate.
Try the following:
- One or more Printhead has been changed.
 - Perform the Service menu > Paper Advance routine to calibrate the paper advance.
- System Error:** 97:YZ
Problem Description: The Calibration of the Paper advance doesn't activate.
Try the following:
- Some critical part has been changed.
 - Perform the Service menu > Paper Advance routine to calibrate the paper advance.



Ink Supplies Troubleshooting

3

- What are Ink Supplies? 3-2
 - Ink Cartridges 3-2
 - Printheads 3-3
- General Information About the Ink Supplies 3-3
- General Precautions When Handling Ink Supplies 3-4
- When Should You Replace the Ink Supplies? 3-4
- Ink Cartridge Status 3-4
- Obtaining Ink Cartridge Information 3-5
- Changing an Ink Cartridge 3-6
- Obtaining Printhead Information 3-10
- Changing a Printhead 3-11
- Aligning Printheads 3-14
 - Reinsert printheads procedure 3-14
 - Image Quality Maintenance menu procedure 3-15
 - Scanning errors during alignment 3-16
- Ink Cartridge Levels 3-16
- Ink Cartridge Status Messages 3-17
- Printhead status messages 3-17
- Summary of Solving Ink Supplies Problems 3-18
 - You Cannot Insert the Ink Cartridge Into the Printer 3-18
 - You Cannot Insert the Printhead Into the Printer 3-18
 - The front panel recommends resetting or replacing a printhead 3-18
 - Clean the printheads 3-19
- Carriage Interconnect Wiper 3-20

What are Ink Supplies?

For each of the ink colors used in the printer, there are two components, the Printhead and Ink Cartridge. These components are called Ink Supplies.

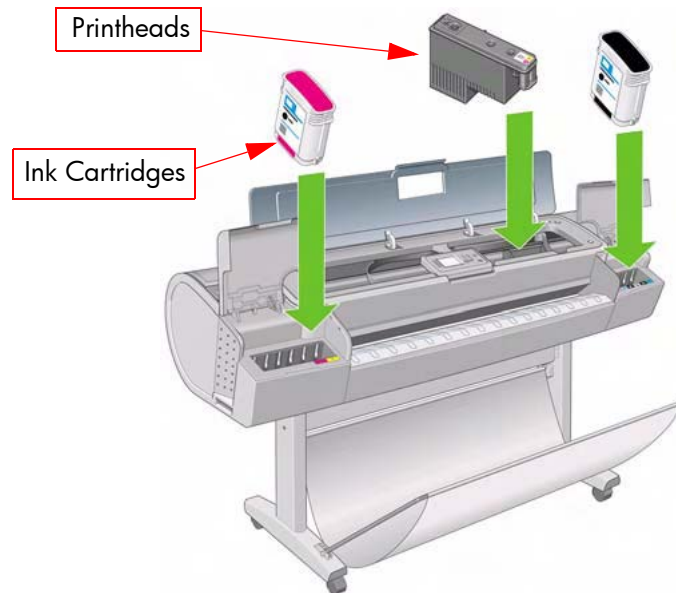

Ink Cartridges

The printer's eight Ink Cartridges provide matte black, photo black, light gray, cyan, magenta, yellow, light magenta, and light cyan ink to the Printheads. The color Ink Cartridges supplied with the printer have a capacity of 69ml but optional 130 ml are also available.

All these Ink cartridges are physically the same size, only the internal capacity varies.



The Ink Cartridges for the Z2100/Z3100 Photo Printer series require no maintenance or cleaning. As long as each Ink Cartridge is inserted correctly into its slot, the ink will flow to the Printheads. Because the Printheads control

the amount of ink transferred to the page, you will continue to see high-quality printing results even when the ink levels are getting low.

The front panel displays the status of the Ink Cartridge. Using the front panel, detailed information can be checked on the Ink Cartridges.

Printheads

The Printheads are extremely durable and do not need to be replaced every time an Ink Cartridge is replaced. They are independent of the Ink Cartridges and will continue giving excellent image quality results even if the Ink Cartridges are low on ink.

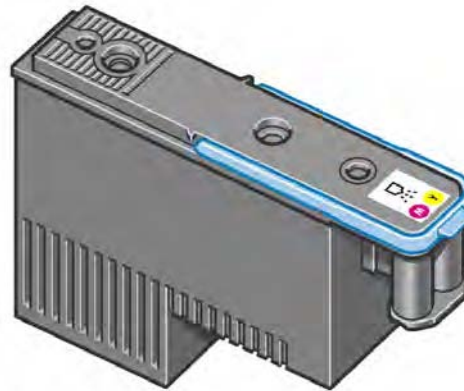

If you notice a decline in print quality such as lines or dots missing from text/graphics, go to Page 6-18, *Troubleshooting Print Quality Problems*.

General Information About the Ink Supplies

For optimum results from the printer and modular ink delivery system always follow these guidelines when handling the ink supplies:

- Always install the Ink Cartridges and Printheads before the expiration date, which is on the packaging.
- Install Ink Cartridges and Printheads in their color-coded slots.
- Follow the instructions on the front panel of the Printer during installation.
- Avoid unnecessary removal of the Ink Cartridges and Printheads.
- When turning off the Printer always use the power Off button on the front panel. The Printheads are then stored correctly which prevents them from drying out.
- The Ink Cartridges should never be removed while the printer is printing. They should only be removed when the printer is ready for you to replace them. The front panel will guide you through the removal and installation procedure.

General Precautions When Handling Ink Supplies

Use the following precautions when handling Ink Supplies:

Do not touch, wipe or attempt to clean the printhead nozzles. This can damage the printhead.

- Handle the ink supplies with care. In particular the Printhead, which is a high precision device and must be handled carefully.
- Do not touch the Printhead nozzles.
- Do not put the Printhead down on the nozzles.
- Do not be rough when handling the Printheads. Always set them down gently.
- Do not drop the Printheads.
- Proper handling will assure optimum performance throughout the Printhead life.
- Do not touch the end of the Ink Cartridge which is inserted into the printer as there may be a small amount of ink on the connection.
- Avoid storing partially used Ink Cartridges on their ends.

When Should You Replace the Ink Supplies?

When to change the ink supplies is mostly determined by you with guidance from the front panel. In conjunction with the messages displayed in the front panel and the message explanations in this chapter, you will be able to choose for yourself when is the right time to change the ink supplies.

The Printer will also display the ink level and will tell you when the ink supply is low on ink. This means you have constantly updated information about the ink supplies.

Ink Cartridge Status

Trough out this chapter all the example Front Panel screens are for the Z2100 Photo Printer unless otherwise stated.

There are two methods for checking the ink levels of your Ink Cartridges:

- Pressing the “View ink level” direct access key on the Front Panel:

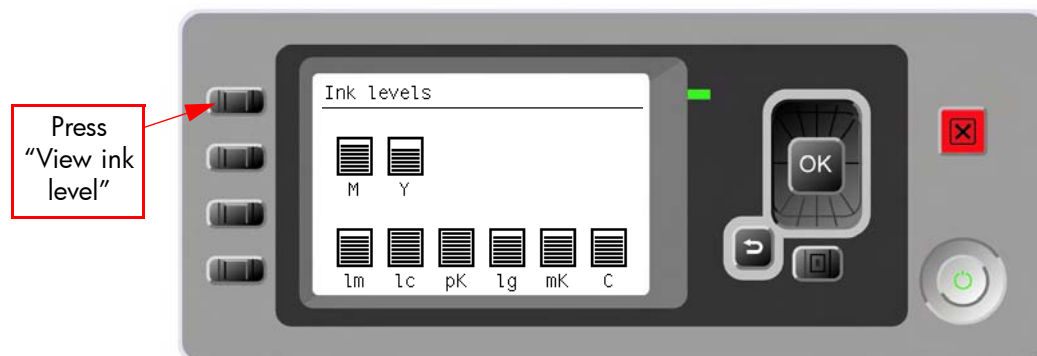

- Choosing the **View ink levels option** from the Ink menu:

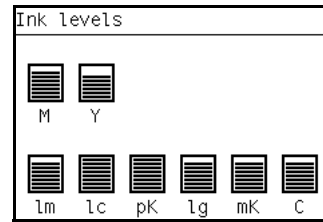

Obtaining Ink Cartridge Information

1. Scroll to the Ink Menu icon and press **OK**.

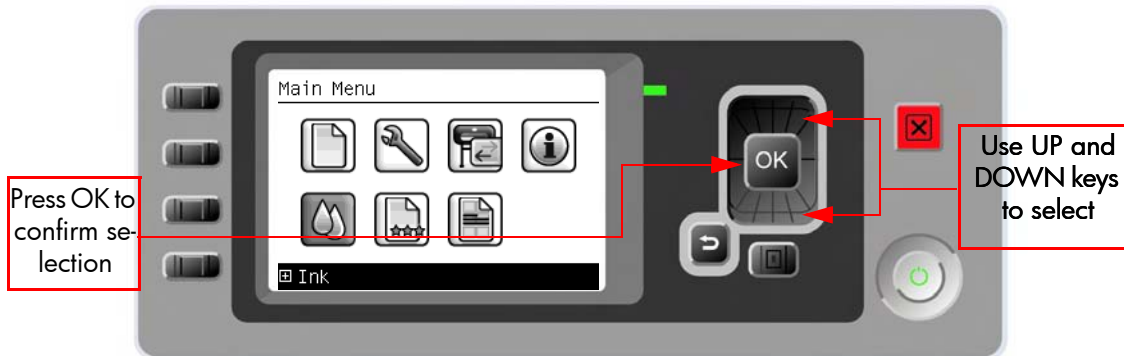

2. In the Ink Menu submenu, scroll to **Ink cartridge information** and press **OK**.

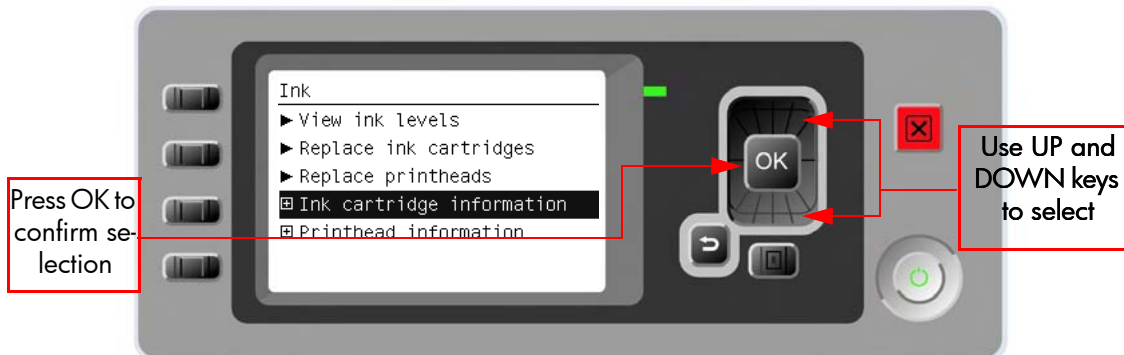

3. In the Ink Cartridge Information submenu, scroll to the Ink Cartridge that you want information on and press **OK**.

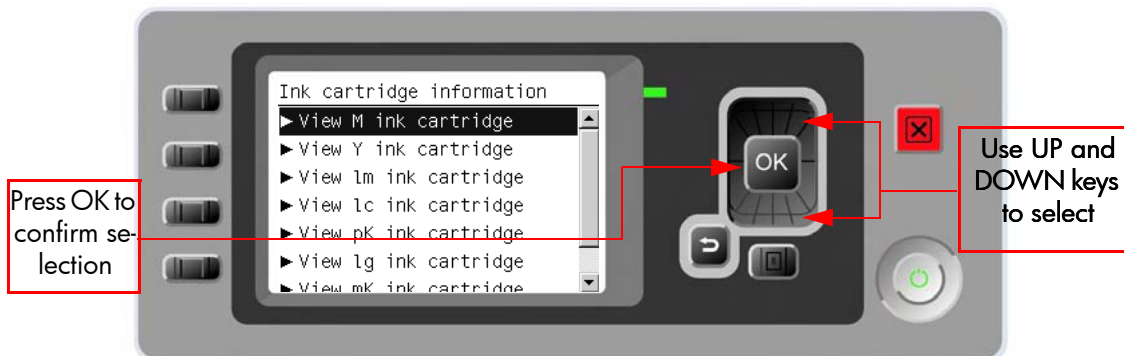

4. The front panel displays information on the selected Ink Cartridge.

```
M ink cartridge
Color: Magenta
Product name: HP 70
Product number: C9441A
Serial number: 786789-32-10
Status: OK
Ink level: 56 ml
Capacity: 69 ml
Expiration date: Feb 14,
```

```
M ink cartridge
Status: OK
Ink level: 56 ml
Capacity: 69 ml
Expiration date: Feb 14,
2010
Warranty status: In
warranty
Manufacturer: HP
```

The information supplied is:

- The make of the Ink Cartridge (hp no.70 is recommended).
- The product number of the Ink Cartridge.
- The serial number of the Ink Cartridge.
- The current status of the Ink Cartridge.
- The current ink level of the ink cartridge in milliliters.
- Original capacity of the ink cartridge in milliliters.
- The manufacturer of the Ink Cartridge (hp is recommended).
- The current warranty status of the Ink Cartridge.

Changing an Ink Cartridge

There are two occasions when you need to remove an ink cartridge:

- The ink cartridge is very low and you want to replace it with a full cartridge for unattended printing (you can use up the remaining ink in the first cartridge at a more convenient time).
- The ink cartridge is empty or faulty, and you must replace it to continue printing.

**Do not try to remove an ink cartridge while printing.
Remove an ink cartridge only if you are ready to insert another one.
Make sure the printer wheels are locked (the brake lever is pressed down) to prevent the printer from moving.**

1. Scroll to the Ink Menu icon and press **OK**.

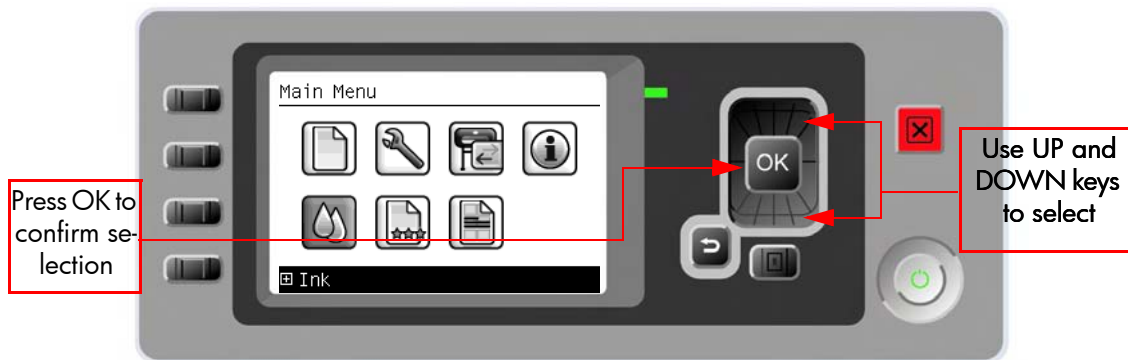

2. In the Ink Menu submenu, scroll to **Replace ink cartridges** and press **OK**.

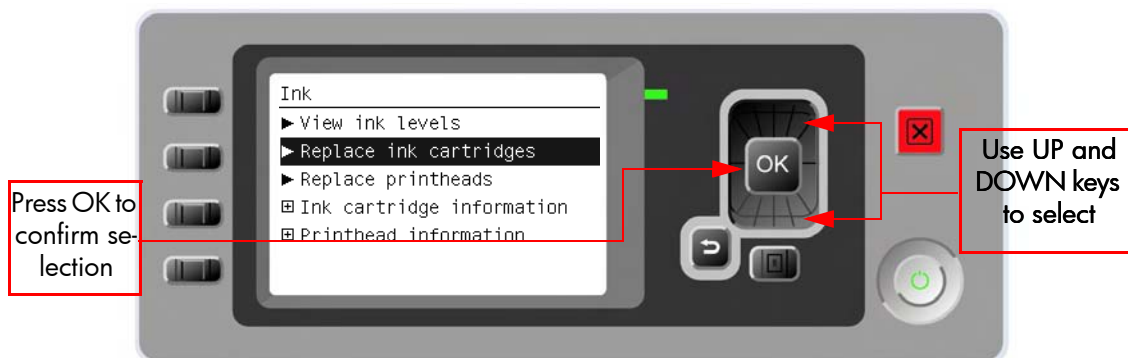

3. The front panel displays the status of the Ink Cartridges.

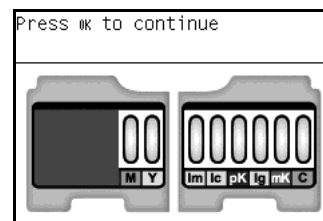

4. Press **OK** to continue.
5. Open the relevant Ink Cartridge cover for the Ink Cartridge you want to replace.
6. Pull the required Ink Cartridge straight up to remove it from the printer.
7. The front panel displays identifies the missing Ink Cartridge.

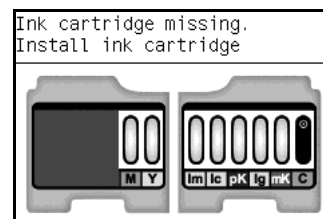

8. Before removing the cartridge from its wrapping, shake it vigorously.

9. Unwrap the new ink cartridge, find the label identifying the ink color. Check that the letter or letters marking the empty slot, matches the letter or letters on the cartridge label.

Z3100 Cartridges		Part number
HP 70 Matte Black 130 ml	Ink Cartridge	C9448A
HP 70 Photo Black 130 ml	Ink Cartridge	C9449A
HP 70 Gray 130 ml	Ink Cartridge	C9450A
HP 70 Light Gray 130 ml	Ink Cartridge	C9451A
HP 70 Magenta 130 ml	Ink Cartridge	C9453A
HP 70 Yellow 130 ml	Ink Cartridge	C9454A
HP 70 Light Magenta 130 ml	Ink Cartridge	C9455A
HP 70 Red 130 ml	Ink Cartridge	C9456A
HP 70 Green 130 ml	Ink Cartridge	C9457A
HP 70 Blue 130 ml	Ink Cartridge	C9458A
HP 70 Gloss Enhancer 130 ml	Ink Cartridge	C9459A
HP 70 Light Cyan 130 ml	Ink Cartridge	C9390A
HP 70 Matte Black 130 ml	Ink Cartridge Twin Pack	CB339A
HP 70 Photo Black 130 ml	Ink Cartridge Twin Pack	CB340A
HP 70 Gray 130 ml	Ink Cartridge Twin Pack	CB341A
HP 70 Light Gray 130 ml	Ink Cartridge Twin Pack	CB342A
HP 70 Magenta 130 ml	Ink Cartridge Twin Pack	CB344A
HP 70 Yellow 130 ml	Ink Cartridge Twin Pack	CB345A
HP 70 Light Magenta 130 ml	Ink Cartridge Twin Pack	CB346A
HP 70 Red 130 ml	Ink Cartridge Twin Pack	CB347A
HP 70 Green 130 ml	Ink Cartridge Twin Pack	CB348A
HP 70 Blue 130 ml	Ink Cartridge Twin Pack	CB349A
HP 70 Gloss Enhancer 130 ml	Ink Cartridge Twin Pack	CB350A
HP 70 Light Cyan 130 ml	Ink Cartridge Twin Pack	CB351A

Z2100 Cartridges		Part number
HP 70 Matte Black 130 ml	Ink Cartridge	C9448A
HP 70 Photo Black 130 ml	Ink Cartridge	C9449A
HP 70 Light Gray 130 ml	Ink Cartridge	C9451A
HP 70 Cyan 130 ml	Ink Cartridge	C9452A
HP 70 Magenta 130 ml	Ink Cartridge	C9453A
HP 70 Yellow 130 ml	Ink Cartridge	C9454A
HP 70 Light Magenta 130 ml	Ink Cartridge	C9455A
HP 70 Light Cyan 130 ml	Ink Cartridge	C9390A
HP 70 Matte Black 130 ml	Ink Cartridge Twin Pack	CB339A
HP 70 Photo Black 130 ml	Ink Cartridge Twin Pack	CB340A
HP 70 Light Gray 130 ml	Ink Cartridge Twin Pack	CB342A
HP 70 Cyan 130 ml	Ink Cartridge Twin Pack	CB343A
HP 70 Magenta 130 ml	Ink Cartridge Twin Pack	CB344A
HP 70 Yellow 130 ml	Ink Cartridge Twin Pack	CB345A
HP 70 Light Magenta 130 ml	Ink Cartridge Twin Pack	CB346A
HP 70 Light Cyan 130 ml	Ink Cartridge Twin Pack	CB351A

- 10.** Insert the ink cartridge into its slot.
- 11.** Push the cartridge into the slot until it snaps into position. You should hear a beep and see confirmation that the cartridge has been inserted.

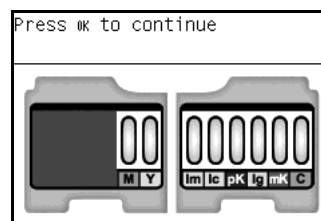

- 12.** When all cartridges have been inserted, close the cover.

Obtaining Printhead Information

1. Scroll to the Ink Menu icon and press **OK**.

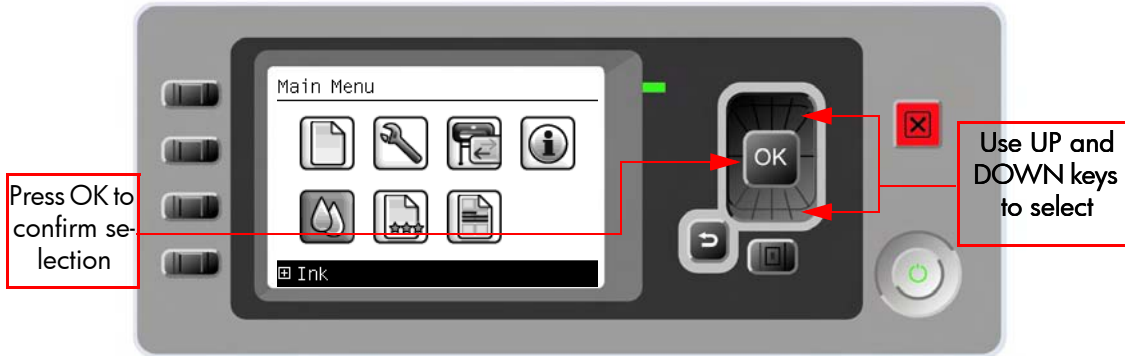

2. In the Ink Menu submenu, scroll to **Printhead information** and press **OK**.

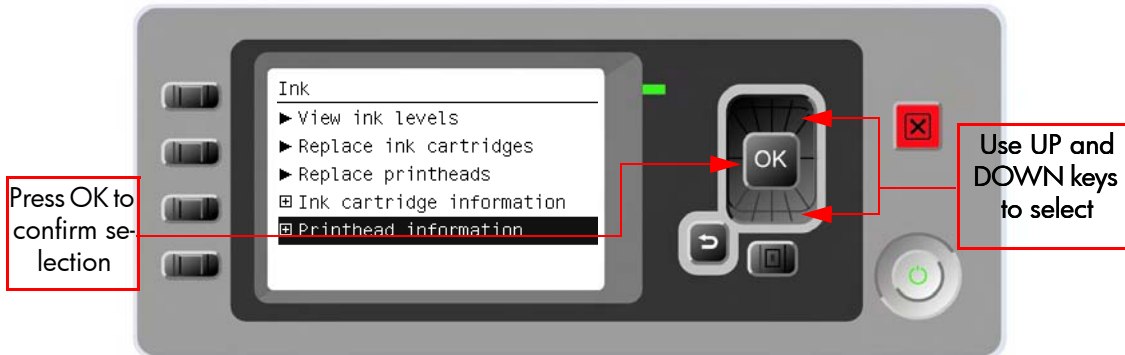

3. In the Printhead Information submenu, scroll to the Printhead that you want information on and press **OK**.

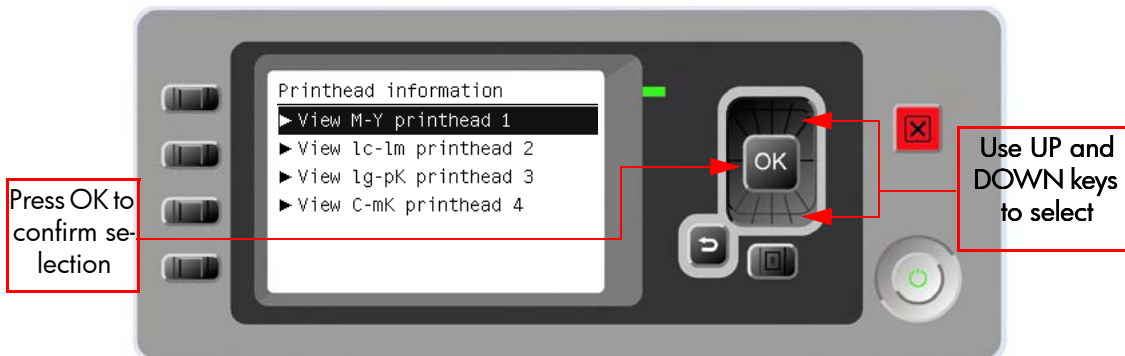

4. The front panel displays information on the selected Printhead.

```
M-Y printhead 1
Color: Magenta-Yellow
Product name: HP 70
Product number: C9406A
Serial number: 4-1-1556765-29-
2006
Status: OK
Ink fired: 36 ml
Warranty status: In warranty
```

The information supplied is:

- The make of the printhead (hp no.70 is recommended).
- The product number of the Printhead.
- The serial number of the Printhead.
- The current status of the printhead.
- How much ink has been fired (consumed) by the printhead. **Note:** It is possible for a printhead to consume more than one Ink Cartridge.
- The current warranty status of the Printhead.

Changing a Printhead

1. Scroll to the Ink Menu icon and press **OK**.

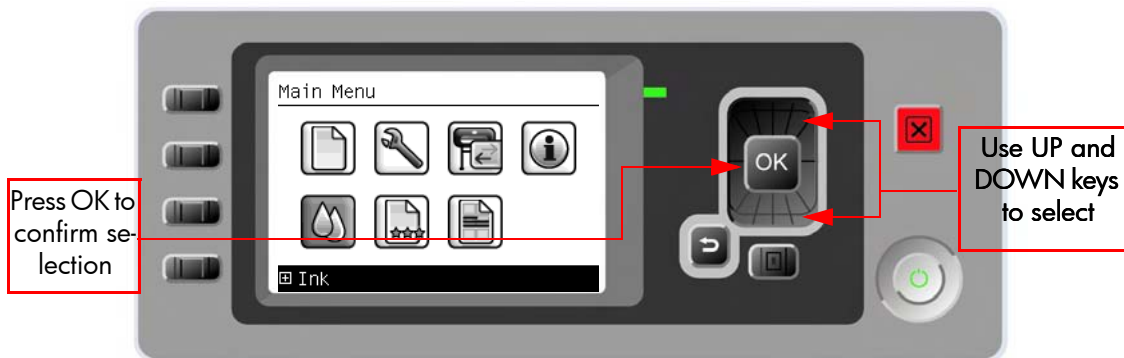

2. In the Ink Menu submenu, scroll to **Replace printheads** and press **OK**.

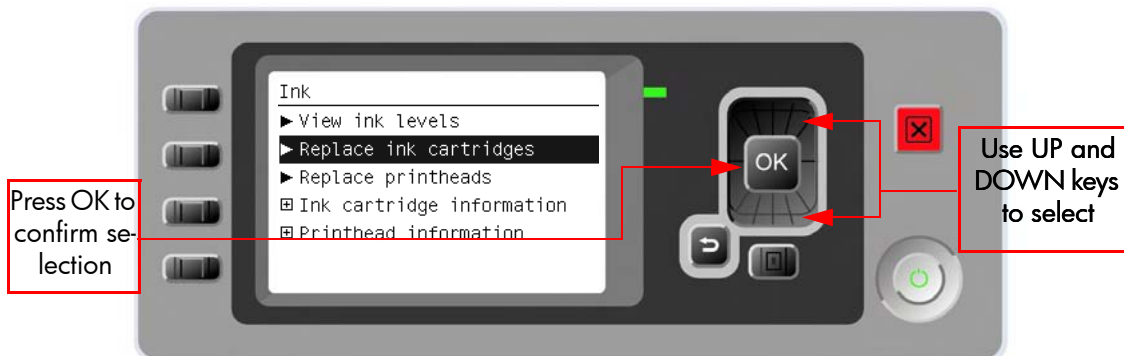

3. The printer moves the Carriage to the correct position to replace Printheads.

If the carriage is left in the removal position for more than three minutes without inserting or removing any printheads, it will try to move back to its normal position at the right-hand end.

4. When the carriage has stopped moving, the front panel display will prompt you to open the window.

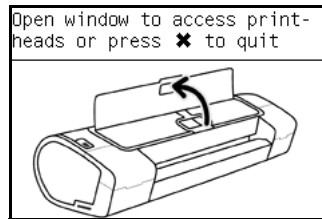

5. Open the window.
6. Lift the Carriage cover to access the printheads.

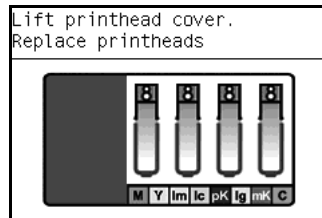

7. Lift the blue handle and pull the Printhead straight up out of the Carriage,
8. To insert a new printhead first remove the orange protective caps.

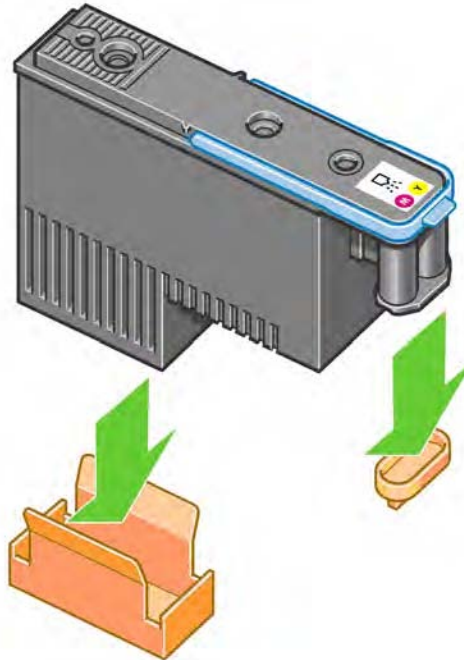

9. Clean the bottom of the printhead by wiping a cotton swab moistened with de-ionized or distilled water. Do not touch the electrical connections on the backside of the printhead.

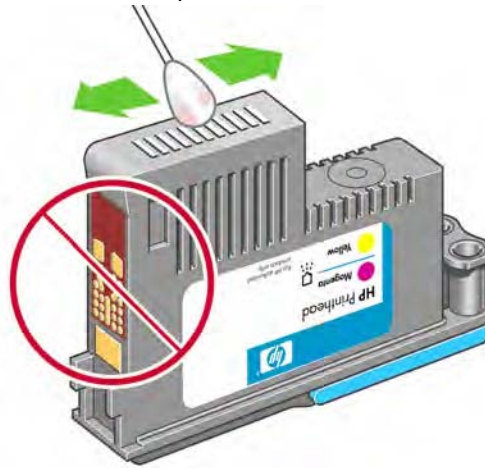

10. The printhead is designed to prevent you from accidentally inserting it into the wrong slot. Check that the colored label on the printhead matches the colored label of the carriage slot into which the printhead is to be inserted. Insert the printhead slowly and vertically, straight down. It may be damaged if you insert it too fast, or at an angle, or if you rotate it as you insert it.

Printhead Type	Printer Model	Part number
HP 70 Matte Black & Cyan	Z2100	C9404A
HP 70 Light Magenta & Light Cyan	Z2100/Z3100	C9405A
HP 70 Magenta & Yellow		C9406A
HP 70 Photo Black & Light Gray		C9407A
HP 70 Blue & Green	Z3100	C9408A
HP 70 Matte Black & Red		C9409A
HP 70 Gloss Enhancer & Gray		C9410A

11. Insert all other printheads that need to be installed, and close the carriage cover.

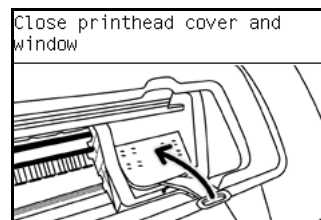

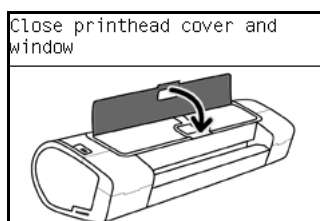
12. Close the Window.

13. When all the printheads have been inserted correctly and accepted by the printer, the printer will beep. If the printer does not beep when you insert the printhead and the **Replace** message appears on the front panel display, the printhead may need to be reinserted.

The front panel display confirms that all printheads are correctly inserted. The printer will start checking and preparing the printheads. The default routine process, when all printheads are changed, takes 25 minutes. If the printer finds problems in preparing the printheads, it will take longer, up to 55 minutes. For a single printhead insertion, the times vary between 15 and 35 minutes. After all printheads are checked and prepared, for the printhead realignment.

Aligning Printheads

Precise alignment between printheads is essential for accurate colors, smooth color transitions, and sharp edges in graphical elements. Your printer has an automatic printhead alignment process which runs whenever a printhead has been accessed or replaced.

In cases where the paper has jammed, you have used a custom paper, or are experiencing problems with color accuracy you may need to align the printheads. If the paper has jammed, it is recommended that you reinsert the printheads and initiate the realignment procedure with the Image Quality Maintenance menu.

Do not use transparent and semi-transparent paper to align the printheads. Photo paper is recommended for the best quality.

Reinsert printheads procedure

- 1.** If the realignment process is running and the wrong paper is loaded, press the cancel key on the front panel. Do not print if the realignment process has been canceled. You can restart the alignment with the Image Quality Maintenance menu procedure.
- 2.** Load the paper you wish to use, . You can use a roll or cut sheet, however, it must be A3 landscape or larger.
- 3.** Remove and re-insert all the printheads, see Remove a printhead and Insert a printhead. This will start the printhead alignment procedure.
- 4.** Ensure the transparent window closed, as a strong light source near the printer during printhead realignment can affect alignment.
- 5.** The process will take about six minutes. Wait until the front panel display shows the process complete before using the printer.

Image Quality Maintenance menu procedure

1. Load the paper you wish to use, You can use a roll or cut sheet, however, it must be A3 landscape or larger (420 by 297 mm). Do not use transparent and semi-transparent paper to align the printheads. Photo paper is recommended for the best results; plain, bond and thin coated papers provide acceptable but marginal results.
2. Press the Menu key to return to the main menu and select the Image Quality Maintenance menu icon.
3. Select Align printheads. The printer will check to see if it has enough paper to run the realignment.
4. If the loaded paper is satisfactory, the printer will run the realignment and print a realignment pattern. Ensure the transparent window is closed, as a strong light source near the printer during printhead realignment can affect alignment.

Z2100 Plot:

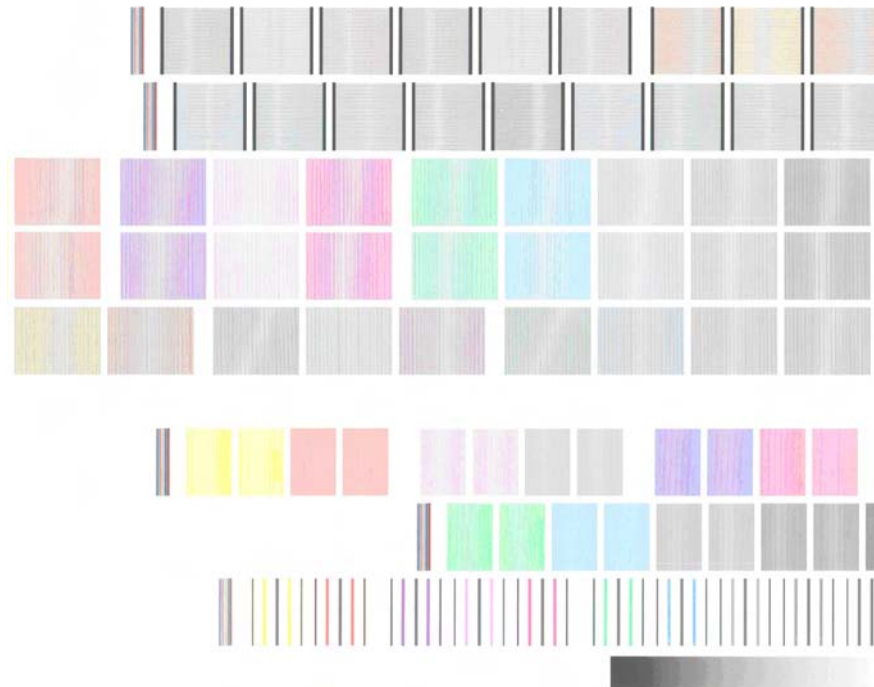

Z2100 Plot:

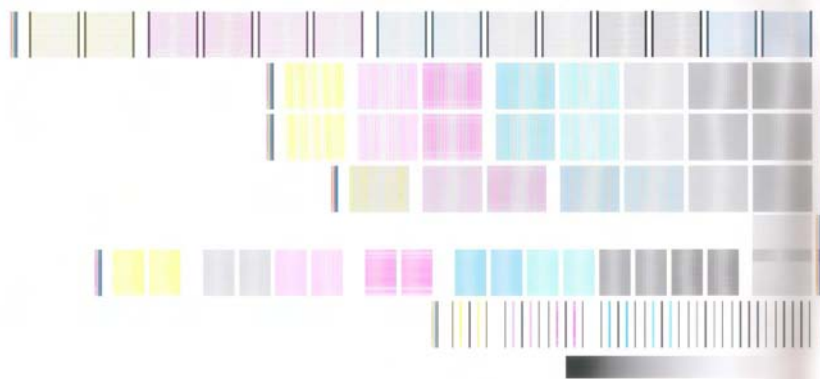

5. The process will take about five minutes. Wait until the front panel display shows the process complete before using the printer.

Scanning errors during alignment

If the alignment process FAILs, a Scanning problems message appears on the front panel. This means that the alignment has not completed successfully. Therefore the printer is not aligned and the alignment should be repeated before printing with good image quality. The problem may be due to:

- The paper used was not valid, repeat the alignment with valid paper
- Printhead health problems, clean printheads, see [Clean the printheads](#)
- The alignment was done with the transparent window open, repeat the alignment with the window closed

If the problem persists after using valid paper, cleaning the printheads, and keeping the window closed, there may be a Failure in the scanning system needing reparation or the printheads, although clean, may not work and need to be replaced.

Ink Cartridge Levels

Level Bars

The front panel displays Ink Levels shown as level bars. These bars represent how much ink is remaining in the Ink Cartridges: as ink is used up the bars get shorter in length. To see how much ink is remaining, go to the **Ink Cartridge Information** submenu. See Page 3-5, *Obtaining Ink Cartridge Information*

Ink Cartridge Status Messages

OK	The Ink Cartridge is operating correctly and no action is required.
Missing	There is no Ink Cartridge present, or it is not properly connected to the printer
Low	The Low message is an early warning sign and it is advisable that new supplies should be obtained of that particular color. The amount of ink remaining in the Ink Cartridge depends on it's capacity, but there is approximately 14% of ink available for the user.
Very Low	When the Very Low message is displayed, overnight printing should not be attempted. Changing the Ink Cartridge is strongly recommended to prevent the printer from stopping halfway through a print. There is approximately 8% of ink available for the user.
Empty	The printer will stop and will not be able to continue printing until a new Ink Cartridge has been installed. If this occurs halfway through printing an image, you should check the quality of this image, as stopping mid-plot can affect the print. It would be recommended to reprint the image once a new Ink Cartridge has been installed.
Reseat	You are recommended to remove the Ink Cartridge and then reinsert it.
Replace	You are recommended to replace the Ink Cartridge with a new Ink Cartridge.
Altered	There is something unexpected about the Ink Cartridge's status.
Expired	The Ink Cartridge has passed the expiration date.

Printhead status messages

OK	The Printhead is operating correctly and no action is required.
Missing	There is no Printhead present, or it is not properly connected to the printer.
Test printhead separately	You are recommended to test the printheads individually to find the failing printhead. Remove all the printheads and insert them alone one by one, Closing the latch and the carriage cover after every insertion. The front panel display will indicate the failing one showing the reseat or replace message.
Reseat	You are recommended to start the printhead removal process from the front panel, but instead of removing the printhead, simply press the OK key on the front panel.

Replace	You are recommended to remove the printhead and then reinsert it; if that fails, clean the electrical connections; if that fails, replace the printhead with a new printhead.
Replacement incomplete	A printhead replacement process has not completed successfully, relaunch the replacement process and let it finish completely (it is not needed to change the printheads).
Remove	The printhead is not a suitable type for use in printing (for instance, a setup printhead).

Summary of Solving Ink Supplies Problems

Most of the problems that you could encounter when working with the ink supplies are solved with guidance from the front panel. A full list of front panel messages are supplied in the User's Guide.

You Cannot Insert the Ink Cartridge Into the Printer

1. Ensure that you have the correct hp no.70 Ink Cartridge.
2. Ensure that the Ink Cartridge is the correct color for that slot.
3. Ensure that the Ink Cartridge is the correct orientation, with the color coded label at the top.

Never clean inside the Ink Cartridge slots as this can cause damage to the Printer.

You Cannot Insert the Printhead Into the Printer

1. Ensure that you have the correct hp no.70 Printhead.
2. Ensure that the printhead is the correct color for that slot.
3. Ensure that the printhead is in the correct orientation.
4. Ensure that the protective cap is removed from the Printhead.

The front panel recommends resetting or replacing a printhead

1. From the front panel, turn the power off then on.
2. Check the front panel display message, if it shows the ready message, the printer is ready to print. If the problem remains continue with the next step.
3. Remove the printhead,
4. Clean the electrical connections on the backside of the printhead with a lint free cloth. You can carefully use a mild rubbing alcohol if moisture is needed to remove residue. Do not use water. You can use Carriage Interconnect Wiper

This is a delicate process and may damage the printhead. Do not touch the nozzles on the bottom side of the printhead, especially not with any alcohol.

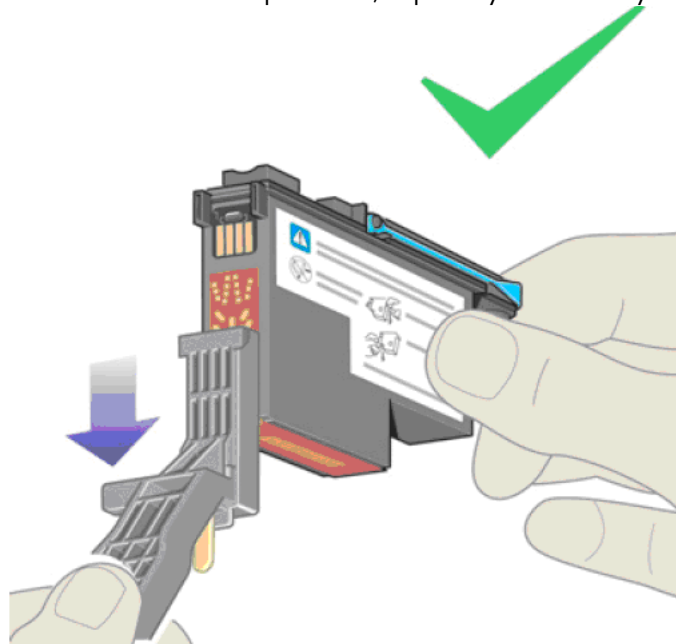

5. Reinsert the printhead, see Insert a printhead.
6. Check the front panel display message. If the problem remains, try a new printhead.

Clean the printheads

As long as the printer is kept turned on, an automatic cleaning is performed periodically. This ensures there is fresh ink in the nozzles and prevents nozzle clogs, which ensures color accuracy.

If you have not already done so, please refer to Horizontal lines across the image (banding) and The Image Diagnostics Print before proceeding.

To clean the printheads, press the Menu key to return to the main menu and select the Image Quality Maintenance menu icon, then Clean printheads. If you have gone through the Image Quality Diagnostic print process, you know which colors are failing. Select to the pair of printheads which contain the failing colors. If you are not sure which colors to clean, you can also select to clean all printheads.

Cleaning all printheads takes about nine minutes. Cleaning a single pair of printheads takes about six minutes. Cleaning all printheads uses more ink than cleaning a single pair.

If you have cleaned the printheads using the Clean printheads procedure from the front panel and are still experiencing image quality problems, you

can try cleaning the printhead nozzles manually using the following procedure.

This is a delicate process and may damage the printhead. Do not touch the electrical connections on the backside of the printhead.

You must remove the printhead (see Remove a printhead) and using a cotton swab and a little de-ionized, distilled water, or Carriage Interconnect Wiper clean the bottom of the printhead until the residue is removed.

Carriage Interconnect Wiper

The Carriage Interconnect Wiper is part of the Maintenance Tool Kit which can be ordered using Part Number Q6683-60690. All the instructions needed to use the Carriage Interconnect Wiper will be packaged with the kit.

Whenever you replace the Printhead, check the empty slots to see if they need cleaning. In extreme circumstances, when a Printhead is inserted, it is possible that the Printer will not recognize it due to the build-up of ink on the electrical connection between the Printhead and the Carriage Assembly.

Included with the Z2100/Z3100 Photo Printer, is a Carriage Interconnect Wiper. This tool is provided in a separate package. It also contains replacement sponges and an instruction sheet. This tool should be used for cleaning the electrical interconnects of both the Carriage Assembly and the Printhead.

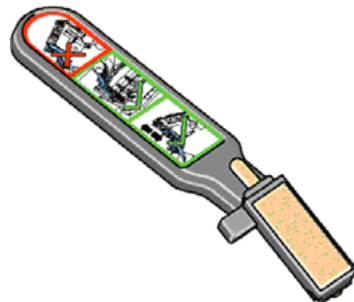

If the front panel displays the message “Reset” or “Replace” next to the offending printhead, try cleaning the flex circuits of the Carriage and the Printheads using the Carriage Interconnect Wiper.

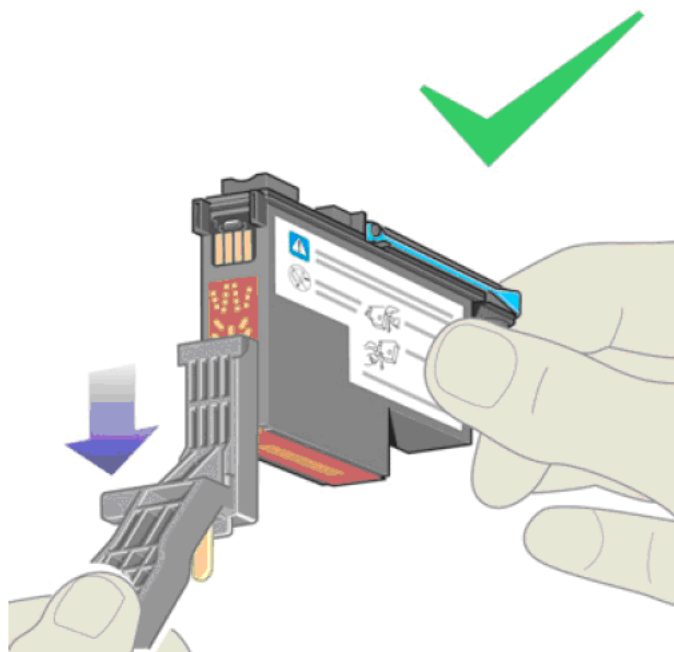

Do not touch, wipe or attempt to clean the printhead nozzles. This can damage the printhead and reduce print quality.

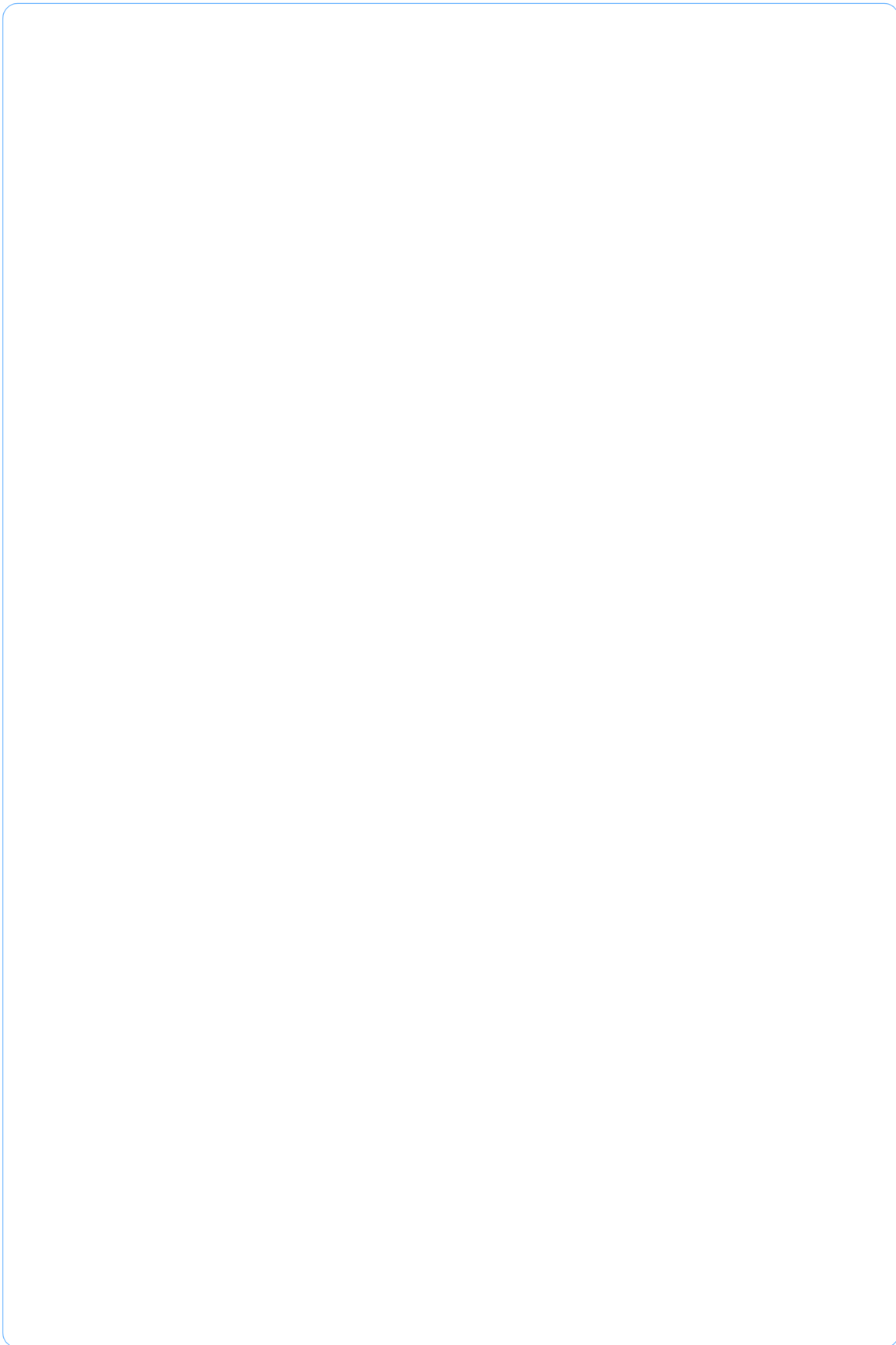

Service Tests and Utilities

4

Introduction	4-2
Diagnostics - Self Test	4-2
Service Tests (Diagnostics)	4-3
Entering the Service Tests Menu	4-5
1. Scan Axis	4-6
2. Paper Drive	4-16
3. Electronics Module	4-20
4. Carriage Assembly	4-25
5. Sensors	4-31
6. Color Sensor (ESP)	4-34
7. Ink Delivery System (IDS)	4-37
8. Service Station	4-41
9. I/O Information	4-47
10. Unit Information	4-48
11. EEROM Reset	4-49
12. Set Unit Configuration	4-51
13. Error 71:19 Recovery	4-52
14. Others	4-55
Service Utilities	4-56
Entering the Service Utilities Menu	4-57
1. Turn Drive Roller	4-59
2. Purge Tubes	4-61
3. Set SN	4-64
4. Reset Life Counters	4-65
5. Diagnostic Print	4-67
6. Set Date and Time	4-68
7. Enable/Disable Firewall	4-69

Introduction

This chapter explains how to use the built-in Service Tests and Service Utilities and what to do if any of the Service Tests FAIL.

If possible, always perform a Service Test on the component that you are about to replace, just to make sure that is the component that has FAILED. If the test on that component passes, there is no need to replace it.

Diagnostics - Self Test

Initialization Sequences

Whenever the Printer is switched ON, it automatically performs a series of internal self tests and mechanical initialization sequences. If any of the parts FAIL, a system error will appear and you should consult 2, *System Error Codes*.

Phone Support

In certain circumstances, a Call Agent can try and troubleshoot the Printer by requesting the Customer to perform a Service Test via the phone. Using this process, it can be determined whether the Printer requires any on-site maintenance.

Remember that the Key combination for the Customer to Enter the Service Tests and Utilities is different from the one that the Customer Engineer will use.

Service Tests (Diagnostics)

The following is a list of all internal Service Tests available in the Printer. Instructions for entering the Service Tests menu are given on Page 4-5.

- 1** Scan Axis Test ⇒ Page 4-6
The purpose of this test is to verify the operation of components related to the Scan Axis.
- 2** Paper Drive Test ⇒ Page 4-16
The purpose of this test is to verify the operation of components related to the Media Axis.
- 3** Electronics Module ⇒ Page 4-20
The purpose of this test is to verify the operation of the:
 - Main PCA (Formatter).
 - Printer Configuration.
 - Power Supply Unit.
 - PrintMech.
 - Carriage Communication.
- 4** Carriage Assembly Test ⇒ Page 4-25
The purpose of this test is to verify the operation of the Carriage Assembly.
- 5** Sensors Test ⇒ Page 4-31
The purpose of this test is to verify the operation of the following Sensors:
 - Window Sensor.
 - Media Lever Sensor.
 - Media Sensor.
- 6** Color Sensor Test ⇒ Page 4-34
The purpose of this test is to verify the operation of the Color Sensor (ESP).
- 7** Ink Delivery Test ⇒ Page 4-37
The purpose of this test is to verify the operation of the Ink Delivery System.
- 8** Service Station Test ⇒ Page 4-41
The purpose of this test is to verify the operation of the Service Station.
- 9** I/O Information ⇒ Page 4-47
The purpose of this test is to verify the TCP/IP configuration.
- 10** Unit Information ⇒ Page 4-48
This option allows you to view the Firmware Version, Part Number, and Serial Number of the Printer.
- 11** EEROM Reset ⇒ Page 4-49

The purpose of this test is to reset the EEROM values.

12 Set Unit Configuration ⇒ Page 4-51

Not implemented.

13 Error 71:19 Recovery ⇒ Page 4-52

The purpose of this utility is to set the Serial Number and Part Number in case both the Formatter and the PrintMech PCA are replaced at the same time or select the correct Serial Number and Part Number if only one of the components has been replaced.

14 I/O Tests ⇒ Page 4-55

Not implemented.

Entering the Service Tests Menu

In order to enter the Service Utility Menu, please refer to the instructions on Page 4-57.

- 1** Make sure the printer is switched OFF from the power switch on the front of the printer and **NOT** from the power switch on the back of the printer.
- 2** For On-Site Engineers, hold the **Up** arrow key and the **OK** key down and switch the printer **ON** using the front power switch. Wait until the LED of the power switch stops flashing (usually after 5 seconds) before releasing ALL three keys.
- 3** Once inside the Service Tests Menu use the **Arrow** keys to scroll through the "Service Tests" selections. Press the **OK** key to begin a specific test when the required Service Test is highlighted.

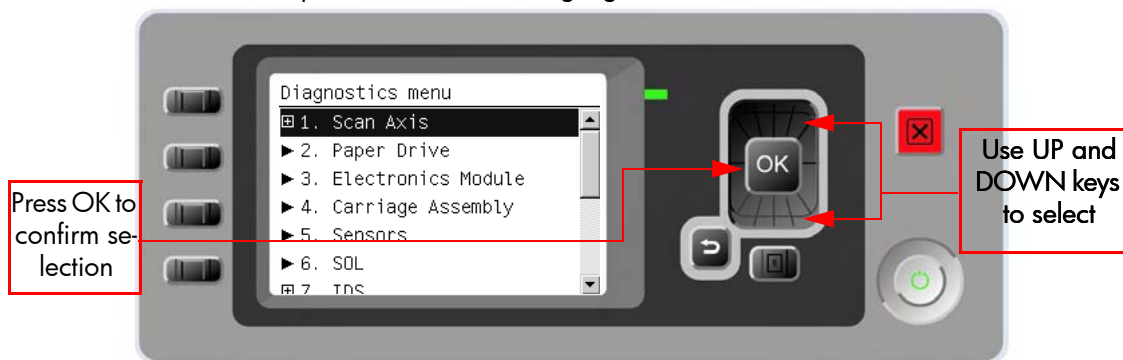

The Service Tests work in a special Mode which does NOT require the full Initialization of the Printer. Therefore it is important that once you have finished with the Service Tests, you MUST power OFF the Printer and Power ON again before trying to print or before executing another Service Test.

In some cases a quick press of a button may not be recognized by the Printer. When pressing a button, be sure to press it deliberately and all the way to the bottom of its travel.

If the Printer hangs up during a test, switch the Printer OFF and restart from step 1.

1. Scan Axis

The complete Scan Axis test consists of individual tests for the different components related to the Scan Axis. The subsystem that are included in this assembly are:

- Star Wheel Lifter
- Automatic PPS Adjustment.
- Scan Axis Servosystem
- Cutter

You must perform the Scan-Axis Test after:

- System Error Code 87:XZ.
- System Error Code 42:XZ.
- System Error Code 47:XZ.
- System Error Code 73:XZ.
- System Error Codes related to Scan-Axis shutdown or Carriage jam.

ALL THE COVER SENSORS ARE DISABLED WHEN IN THE SERVICE TESTS MENU. IF THE CARRIAGE IS MOVING IT WILL NOT STOP IF THE WINDOW IS OPENED, SO BE VERY CAREFUL NOT TO PUT YOUR HANDS INSIDE.

IF POSSIBLE ALWAYS PERFORM THIS TEST BEFORE REPLACING ANY COMPONENT OF THE SCAN-AXIS.

Star Wheel Lifter test

The Star Wheel Lifter subassembly is designed to move the Start Wheel support to the up and down positions. This is used to load roll or sheet media and avoid damage to the Star Wheel caused by paper jams etc.

Perform the Scan Axis - Starwheel lifter test as follows:

Perform this test with the Printheads and the Tubes System installed in order to get values that can be compared correctly.

- 1 In the Diagnostics menu, scroll to **1. Scan Axis** and press **OK**.

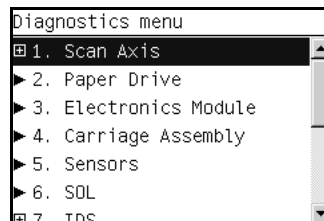

- 2 The Front Panel will show the **1. Scan Axis** submenu.

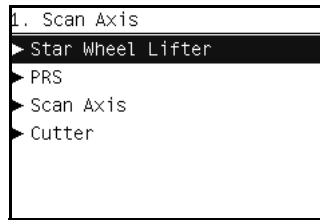

- 3 In the **Scan Axis** submenu, scroll to **Star Wheel Lifter** and press **OK** to start the test.

Star wheel lifter subsystem Common Initialization, Star wheel lifter test initialization, and Star wheel open test. If there is a Failure at any point during the tests, the Front Panel will display the relevant **System Error Code**. To trouble shoot any displayed error codes, refer to page 2-6, *System Error Codes and Warnings - Descriptions* .

The following

- 4 The printer then starts the Star wheel lifter PWM control test to verify the subsystem. As the test executes the Front Panel displays the following messages:
- Starting Horsburgh.
 - Starting Tests PWM.
 - Starting Tests GPIO.
 - Booting up the Carriage.
 - Starting SVS Motor
 - Starting Carriage Motor.
 - Starting Service Station.
 - Starting Scan Axis.
 - Moving SVS out of Scan.
 - Homing Scan Axis.
 - Move Carriage out of SVS path.
 - Starting Servicing Services.
 - Capping SVS.
 - Uncapping SVS.
 - Starting Star Wheels Motor.
 - Checking SVS capped.
 - Getting SWL path length.
 - Checking SWS length.
 - Checking SWL PWM Forward.
 - Moving & Getting traces.
 - Moving SWL Motor
 - Dumping motor traces.
 - Analyzing motor traces.
 - Checking PWM results.
 - Checking SWL PWM Backward.
 - Moving & Getting traces.

- Moving SWL Motor
- Dumping motor traces.
- Analyzing motor traces.
- Checking PWM results.

If there is a Failure at any point during the test, the Front Panel will display the relevant **System Error Code**. To trouble shoot any displayed error codes, refer to page 2-6, *System Error Codes and Warnings - Descriptions*.

- 5 Once the test has completed the Front Panel displays the test results.

```
Star Wheel Lifter
PWM Results (Fw/Bw):
Average: 3597.150/2972.840
Minimum: 1024/512
Maximum: 8064/6656
Max Pos: 108/101 EU/Int
Length: 3666 EU
Press any key to finish.
```

- 6 Press any key finish.

- 7 The Front Panel shows the test complete display for a few seconds.

```
Star Wheel Lifter
      00  K  K
     0 0  K  K
    0 0  KK
   0 0  KK
  0 0  K  K
 00  K  K
```

- 8 The Front Panel prompts you to shutdown the printer to complete the test.

```
Star Wheel Lifter
Press any key to shutdown
the system.
```

- 9 Press any key to shutdown the printer.

PRS Test

The PRS subsystem is designed to move the carriage assembly between two predetermined vertical positions with respect to print platen plane. This allows different media of different thicknesses to be used without losing print quality.

Perform the Scan Axis - PRS test as follows:

Perform this test with the Printheads and the Tubes System installed in order to get values that can be compared correctly.

- 1 In the Diagnostics menu, scroll to **1. Scan Axis** and press **OK**.

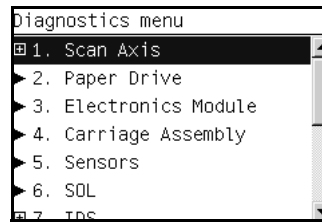

- 2 The Front Panel will show the **1. Scan Axis** submenu.

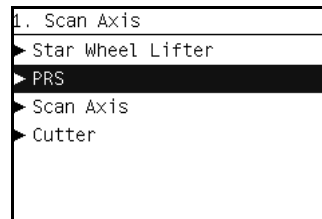

- 3 In the **Scan Axis** submenu, scroll to **PRS** and press **OK** to start the test.

The Printer will start the Scan Axis subsystem Common Initialization and PRS test initialization. If there is a Failure at any point during the tests, the Front Panel will display the relevant **System Error Code**. To trouble shoot any displayed error codes, refer to page 2-6, *System Error Codes and Warnings - Descriptions* .

- 4 The printer then starts the PRS test to verify the subsystem. As the test executes the Front Panel displays the following messages:

- Starting Horsburgh.
- Starting Tests PWM.
- Starting Tests GPIO.
- Booting up the Carriage.
- Starting SVS Motor
- Starting Carriage Motor.
- Starting PpsMotor,
- Starting Service Station.
- Starting Scan Axis.
- Moving SVS out of Scan.
- Homing Scan Axis.
- Move Carriage out of SVS.
- Homing SVS.
- Starting Servicing Services.
- Reading PRS Position.
- Moving PRS position to HIGH position.

If there is a Failure at any point during the test, the Front Panel will display the relevant **System Error Code**. To trouble shoot any displayed error codes, refer to page 2-6, *System Error Codes and Warnings - Descriptions* .

- 5 Once the test has completed the Front Panel displays the test result.

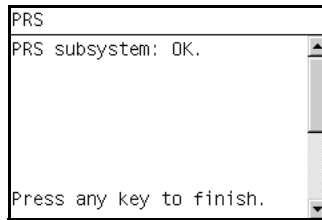

- 6 Press any key finish.
7 The Front Panel shows the test complete display for a few seconds.

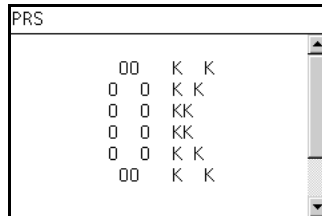

- 8 The Front Panel prompts you to shutdown the printer to complete the test.

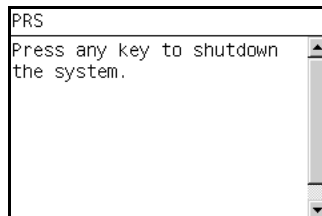

- 9 Press any key to shutdown the printer.

Scan Axis test

The Scan Axis subsystem is designed to move the carriage assembly between two predetermined horizontal positions with respect to the print platen plane. This allows media of different widths to be used without losing print quality.

Perform the Scan Axis - Scan Axis test as follows:

Perform this test with the Printheads and the Tubes System installed in order to get values that can be compared correctly.

- 1 In the Diagnostics menu, scroll to **1. Scan Axis** and press **OK**.

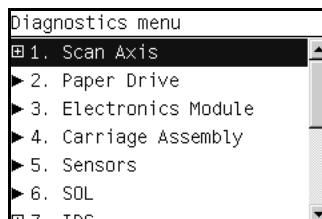

- 2 The Front Panel will show the **1. Scan Axis** submenu.

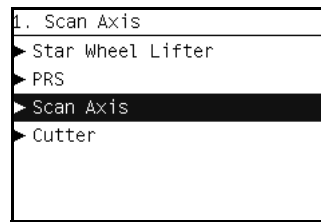

- 3 In the **Scan Axis** submenu, scroll to **Scan Axis** and press **OK** to start the test.

The Printer will start the Scan Axis subsystem Common Initialization. If there is a Failure at any point during the tests, the Front Panel will display the relevant **System Error Code**. To trouble shoot any displayed error codes, refer to page 2-6, *System Error Codes and Warnings - Descriptions* .

- 4 The printer then starts the Scan Axis test initialization. As the test executes the Front Panel displays the following messages:

- Starting Horsburgh.
- Starting PWMManagerDelSol.
- Starting Tests PWM.
- Starting Tests GPIO.
- Starting Nvm.

If there is a Failure at any point during the test, the Front Panel will display the relevant **System Error Code**. To trouble shoot any displayed error codes, refer to page 2-6, *System Error Codes and Warnings - Descriptions* .

- 5 The printer then starts the PSU check. As the test executes the Front Panel displays the following messages:

- Clear GPIO psu_sleep.
- Clear GPIO psu_Carr.
- Clear GPIO psu_fanspeed.
- Checking Voltage.
- Set GPIO psu_Carr.
- Set GPIO psu_sleep.
- Checking Voltage.

- 6 The Front Panel prompts you to confirm that the carriage supply LED is switched on.

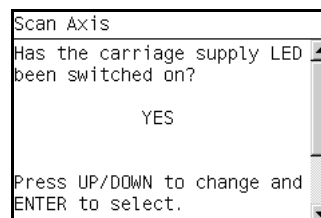

- 7 Open the Window and verify that the LED is on. The LED can be seen through the slots in the carriage cover.

- 8 Press **OK** if the LED is on. If the LED is not on or use the **UP** or **Down** keys to select NO and press **OK**. If you select No the printer will shutdown immediately.
- 9 The printer then continues the Scan Axis test. As the test executes the Front Panel displays the following messages:
 - Booting Up Carriage.
 - Getting Part Number.
 - Getting Scan Axis Size
 - Preparing SVS.
 - Prog slow PWM scan.
 - Moving Carriage middle.

- 10 The Front Panel prompts you to confirm that the Carriage has moved.

```

Scan Axis
Preparing SVS.
Prog slow PWM scan.
Moving carriage middle.
Did the motor move?
      YES
Press UP/DOWN to change and
  
```

- 11 Use the **UP** or **Down** keys to select whether or not the motor moved the carriage.
- 12 Press **OK** to continue.
- 13 The Front Panel prompts you to confirm that the Carriage has moved to the middle position.

```

Scan Axis
Preparing SVS.
Prog slow PWM scan.
Moving carriage middle.
Did the motor move?
Is carriage at middle?
      YES
Press UP/DOWN to change and
ENTER to select...
  
```

- 14 Use the **UP** or **Down** keys to select whether or not the carriage has moved to the middle.
- 15 Press **OK** to continue.
- 16 The printer then continues the Scan Axis test. As the test executes the Front Panel displays the following messages:
 - Preparing SVS.
 - Prog slow PWM scan.
 - Moving Carriage middle.
 - Starting Carriage.
 - Encoder.

- 17** The Front Panel prompts you to move the carriage to check the encoder readings.

```

Scan Axis
Checking encoder readings.
Please keep out from platen
zone and press
UP(left)/DOWN(right) to
move the carriage.

Remaining movements: 10
Last movement: 0 eu
  
```

- 18** Use the **UP** or **Down** keys to move the Carriage left or right as prompted to by the Front Panel.
- 19** Press **OK** to continue.
- 20** Repeat steps 18 and 19 to complete the ten Carriage movements used to check the encoder.
- 21** The Front Panel displays the encoder check results.

```

Scan Axis
Max,Min mov: 528,464 eu
Avg mov: 493 eu
There is encoder feedback.

Encoder seems to be OK.

Press any key to continue.
  
```

- 22** Press any key to continue.
- 23** The printer then continues the Scan Axis test. As the test executes the Front Panel displays the following messages:
- Starting Carriage Motor.
 - On/Off Carriage Motor.
 - Doing a right side bump.
 - Doing a left side bump.
 - Exit bump position.
 - Checking scan axis length.
 - Starting PpsMotor.
 - Starting Scan Axis.
 - Doing PWM test.
- 24** The Front Panel displays the PWM check results.

```

Scan Axis
PWM Average got (Fw/Bw):
11750.036 / 11518.189
PWM min diff limit: 40
PWM min diff got (Fw/Bw):
11004.00 / 11246.00

Press any key to finish.
  
```

- 25** Press any key to finish.
- 26** The printer then continues the Scan Axis test. As the test executes the Front Panel displays the following messages:
- Moving PRS to High Position.

- 27** The Front Panel displays the PRS position check results.

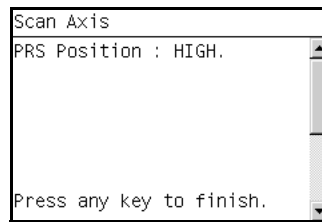

- 28** Press any key finish.
29 The Front Panel shows the test complete display for a few seconds.

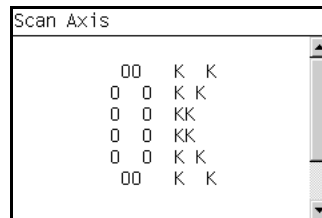

- 30** The Front Panel prompts you to shutdown the printer to complete the test.

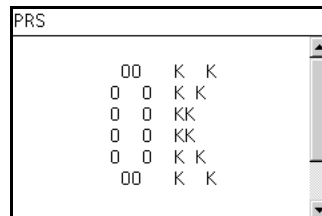

- 31** Press any key to shutdown the printer.

Cutter test

The Cutter is designed to cut roll media after printing for the size of sheet defined. Before executing this test you should run the Scan Axis, Media Path and Carriage tests to ensure that each of these subsystems is operating correctly.

Perform the Scan Axis - Cutter test as follows:

- 1** In the Diagnostics menu, scroll to **1. Scan Axis** and press **OK**.

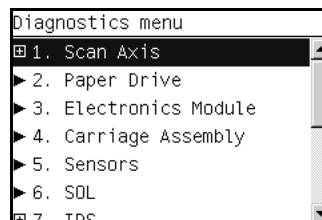

- 2** The Front Panel will show the **1. Scan Axis** submenu.

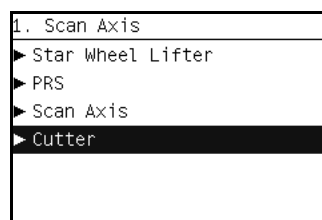

3 In the **Scan Axis** submenu, scroll to Cutter and press **OK** to start the test. The Printer will start the Scan Axis subsystem Common Initialization and Cutter test initialization. If there is a Failure at any point during the tests, the Front Panel will display the relevant **System Error Code**. To trouble shoot any displayed error codes, refer to page 2-6, *System Error Codes and Warnings - Descriptions* .

4 The printer then starts the Cutter test to verify the subsystem. As the test executes the Front Panel displays the following messages:

- Starting Horsburgh.
- Starting TestsGPIO.
- Starting Nvm Motor
- Getting Part Number.
- Starting SvsMotor.
- Starting CarriageMotor.
- Starting ServiceStation.
- Moving SVS to rear bump.
- Homing Scan Axis.
- Move Carriage out of SVS.
- Homing Service Station.
- Starting ServicingServices.
- Capping Service Station.
- Uncapping Service Station.

If there is a Failure at any point during the test, the Front Panel will display the relevant **System Error Code**. To trouble shoot any displayed error codes, refer to page 2-6, *System Error Codes and Warnings - Descriptions* .

5 The Front Panel then prompts you to load roll media.

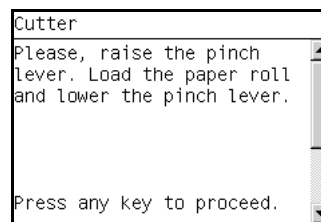

6 Raise the Media Lever, load roll media, lower the Media Lever, and press any key to continue.

7 The printer then starts an actual test cut of the media. As the test executes the Front Panel displays the following messages:

- Advance paper.
- Engaging cutter.
- Cutting paper.
- Disengaging cutter.

- 8 Once the test has completed the Front Panel displays the test result.

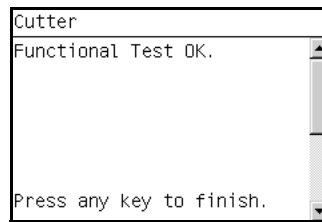

- 9 Press any key finish.
10 The Front Panel shows the test complete display for a few seconds.

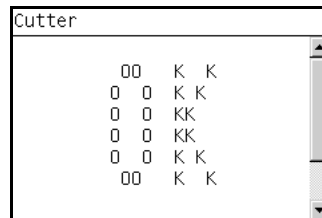

- 11 The Front Panel prompts you to shutdown the printer to complete the test.

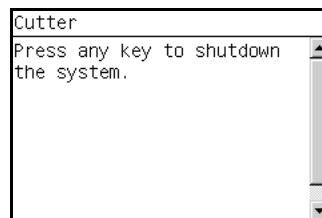

- 12 Press any key to shutdown the printer.

2. Paper Drive

The Paper Drive test diagnoses Failures of components of the Media-Axis.

You must perform the Media Drive Test after:

- System Error Code 81:XZ.
- System Error Code 41:XZ.
- System Error Code 73:XZ.

ALL THE COVER SENSORS ARE DISABLED WHEN IN THE SERVICE TESTS MENU. IF THE CARRIAGE IS MOVING IT WILL NOT STOP IF THE WINDOW IS OPENED, SO BE VERY CAREFUL NOT TO PUT YOUR HANDS INSIDE.

AIF POSSIBLE ALWAYS PERFORM THIS TEST BEFORE REPLACING ANY COMPONENT OF THE MEDIA-AXIS.

Perform the Scan Axis - Starwheel lifter test as follows:

Perform this test with the Printheads and the Tubes System installed in order to get values that can be compared correctly.

- 1 In the Diagnostics menu, scroll to **2. Paper Drive** and press **OK**.

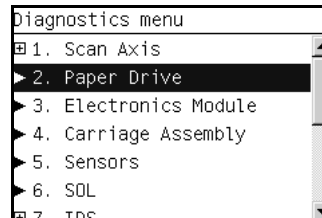

- 2 The printer starts the Paper Drive test to verify the subsystem. As the test executes the Front Panel displays the following messages:
 - Starting Horsburgh.
 - Starting Tests PWM.
 - Starting Tests GPIO.
 - Booting up the Carriage.
 - Starting DelSol1.
 - Starting Carriage.
 - Starting AnalogEncoder.
 - Starting Nvm.
 - Getting Part Number.
 - Getting PCA revision.
- 3 The Front Panel then displays the Main PCA Revision and prompts you to press any key to continue.

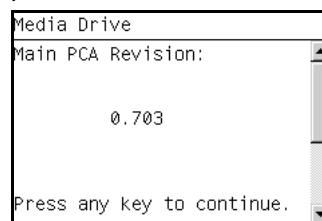

- 4 Press any key to continue.
- 5 The Front Panel displays the following messages:
 - Starting Nvm.
 - Getting Part Number.
 - Checking PCA rev.
 - Prog slow PWM paper.

- 6 The Front Panel then prompts you to remove the media.

```
Media Drive
Please, remove the media
for testing and keep out
from the platen zone.

Press any key to continue.
```

- 7 Remove the media.
8 Press any key to continue.
9 The Front Panel then displays the Open Loop ROLL test result.

```
Media Drive
Checking Open Loop ROLL.
Movement done: 417095 eu.

Press any key to continue.
```

- 10 Press any key to continue.
11 The Front Panel then displays the Open Loop UNROLL test result.

```
Media Drive
Checking Open Loop UNROLL.
Movement done: 558859 eu.

Press any key to continue.
```

- 12 Press any key to continue.
13 The Front Panel then displays:
■ Starting Paper Motor.
■ Starting Paper Axis.
■ Calib. Analog Decoder.
14 The Front Panel then displays the Analog Decoder calibration results.

```
Media Drive
Analog Encoder results:
CHANNEL  GAIN  OFFSET
A         1.0   3.0
B         1.0   8.0

Press BACK/CANCEL to reject
or ENTER to accept.
```

- Press **OK** to accept the results or **BACK/CANCEL** to reject the results.
15 The Front Panel then displays:
■ Starting Media Path.
■ Homing and repeatability test.

- 16** The Front Panel then prompts you to remove the media.

```
Media Drive
Please, remove the media
for testing and keep out
from the platen zone.

Press any key to continue.
```

- 17** Press any key to continue.
- 18** The Front Panel then displays:
- PWM test without paper.

- 19** The Front Panel then displays the test results.

```
Media Drive
PWM avg: 8178.18 / 7700.49
Speed error: 46.25 / 51.25
PWM StDev: 98.52 / 121.22
PWM max: 8458.00 / 8047.00

Press any key to finish.
```

- 20** Press any key to continue.
- 21** The Front Panel shows the test complete display for a few seconds.

```
Media Drive

    00  K  K
   0 0  K K
  0 0  KK
 0 0  KK
 0 0  K K
 00  K  K
```

- 22** The Front Panel prompts you to shutdown the printer to complete the test.

```
Media Drive
Press any key to shutdown
the system.
```

- 23** Press any key to shutdown the printer.

3. Electronics Module

The Electronics Module test diagnoses Failures of the following components:

- Main PCA components
- Electronics Module to Carriage interfacing.
- Print Mech PCA components.
- Power Supply Unit voltages.

Perform the Electronics Module test as follows:

- 1 In the Diagnostics menu, scroll to **2. Electronics Module** and press **OK**.

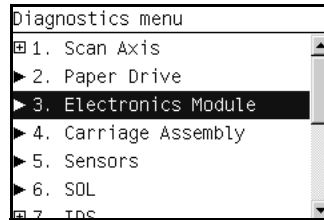

- 2 The printer starts the Electronics Module test to verify the subsystem and prompts you to test the Power Supply:

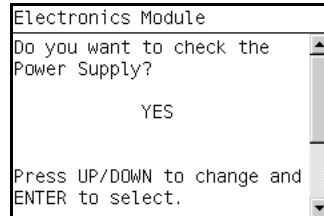

- 3 Press **OK** to test the Power Supply. If you do not wish to test the power supply use the **UP** or **Down** keys to select **NO** and press **OK**.

- 4 The Power supply test starts and the Front Panel displays the following messages:

- Starting Horsburgh.
- Starting DelSol7.
- Starting Carriage.
- Getting PSU voltages.

- 5 The Front Panel then displays the Power Supply test results.

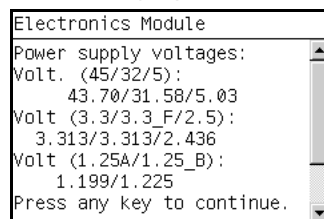

- 6 Press any key to continue.

- 7 The Fan Speed test starts and the Front Panel displays:

- Starting Horsburgh.
- Starting Tests PWM. XXX
- Starting Tests GPIO. XXXX

- Booting up the Carriage. XXXX

- 8 The Front Panel then displays Fan Speed test result and prompts you to press any key to continue.

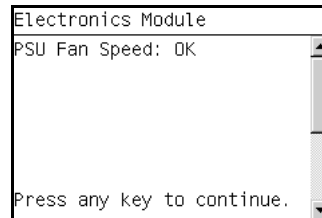

- 9 Press any key to continue.

- 10 The Front Panel then prompts you to test the Formatter.

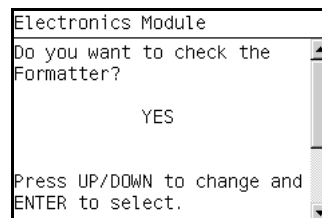

- 11 Press **OK** to the test the Formatter. If you do not wish to test the Formatter use the **UP** or **Down** keys to select NO and press **OK**.

- 12 The Formatter voltage test starts and the front Panel displays the following messages:

- Starting DelSol1.
- Getting PCA revision.

- 13 The Front Panel then displays PCA Rev. Voltage test result and prompts you to press any key to continue.

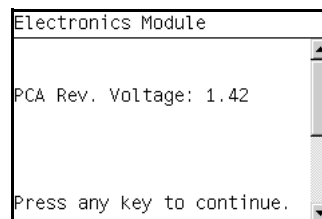

- 14 Press any key to continue.

- 15 The Formatter memory size test starts and the Front Panel displays the following messages:

- Starting DelSol1.
- Getting PCA Revision.
- Checking Memory Size.

- 16** The Front Panel then displays Formatter Memory Size and prompts you to press any key to continue.

```

Electronics Module
Formatter Memory Size:

114MB (0 MB)

Press any key to continue.

```

- 17** Press any key to continue.
- 18** The Formatter hard disk test starts and the Front Panel displays the following messages:
- Starting DelSol1.
 - Getting PCA Revision.
 - Checking Memory Size.
 - Getting HDA info.
- 19** The Front Panel then displays Formatter Hard Disk information test results and prompts you to press any key to continue.

```

Electronics Module
Device Boot Id Blocks
HDA1 * 83 136048+
HDA2 83 1050840
HDA3 83 3152520
HDA6 83 11536528+
HDA7 83 9442408+
HDA8 83 10599088+
Press any key to continue.

```

- 20** Press any key to continue.
- 21** The Formatter hard disk file information test starts and the Front Panel displays the following messages:
- Starting DelSol1.
 - Getting PCA Revision.
 - Checking Memory Size.
 - Getting HDA Info.
 - Getting File System Info.
- 22** The Front Panel then displays Formatter Hard Disk File information test results and prompts you to press any key to continue.

```

Electronics Module
Device 1k-Blocks %Used
HDA1 3102972 64%
HDA2 3102972 64%
HDA3 3102972 64%
HDA6 3102972 64%
HDA7 3102972 64%
HDA8 3102972 64%
Press any key to continue.

```

- 23** Press any key to continue.
- 24** The MainBoard Revision Voltage test starts and the Front Panel displays the following messages:
- Starting DelSol1.

- Getting PCA Revision.
- Checking Memory Size.
- Getting HDA Info.
- Getting File System Info.
- Getting MainBoard Rev.

25 The Front Panel then displays MainBoard Voltage test results and prompts you to press any key to continue.

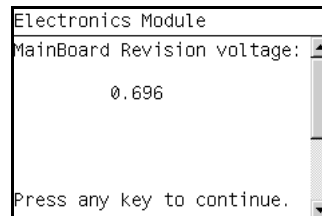

26 Press any key to continue.

27 The Main Memory Size test starts and the Front Panel displays the following messages:

- Starting DelSol1.
- Getting PCA Revision.
- Checking Memory Size.
- Getting HDA Info.
- Getting File System Info.
- Getting MainBoard Rev.
- Getting Main Memory Size.

28 The Front Panel then displays Main Memory size test results and prompts you to press any key to continue.

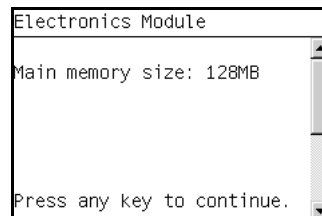

29 Press any key to continue.

30 The Front Panel then prompts you to test the Formatter Communications.

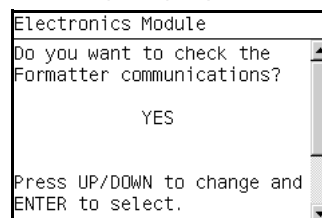

31 Press **OK** to test the Formatter. If you do not wish to test the Formatter use the **UP** or **Down** keys to select **NO** and press **OK**.

32 The Formatter Communications test starts and the front Panel displays the following messages:

- Starting Micci2Bus.
- Starting Micci2BusProxy.
- Checking Communications.

33 The Front Panel then displays Formatter Communications test results and prompts you to press any key to continue.

```

Electronics Module
ID      Device name
1       DelSol1
5       DelSol15
7       DelSol17
2       Luna2
Press any key to continue.

```

34 Press any key to continue.

35 The Plotter information test starts and the front Panel displays the following messages:

- Starting Nvm
- Accessing Nvm.
- Getting Plotter info.

36 The Front Panel then displays Plotter Information test results and prompts you to press any key to finish.

```

Electronics Module
Proto-Name:   LP1
Proto-Product: TROYA-8
Scan Axis size: 24
Press any key to finish.

```

37 Press any key to finish.

38 The Front Panel shows the test complete display for a few seconds.

```

Electronics Module
          00  K  K
         0 0  K  K
         0 0  KK
         0 0  KK
         0 0  K  K
          00  K  K

```

39 The Front Panel prompts you to shutdown the printer to complete the test.

```

Electronics Module
Press any key to shutdown
the system.

```

40 Press any key to shutdown the printer.

4. Carriage Assembly

The Carriage assembly test diagnoses Failures of any components of the Carriage. Always run this test before replacing the Carriage Assembly.:

- 1 In the Diagnostics menu, scroll to **4. Carriage Assembly** and press **OK**.

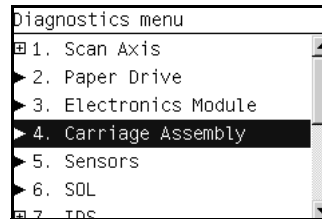

- 2 The Power supply test starts and the Front Panel displays the following messages:

- Starting Horsburgh.
- Starting AdcManagerHorus.
- Starting Carriage.
- Starting Nvm.

- 3 The Front Panel prompts you to verify the Carriage Assembly PCA revision:

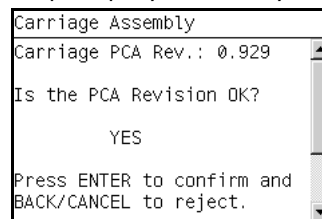

- 4 Press **OK** if the PCA version is correct. If the PCA version is not correct use the **UP** or **Down** keys to select NO and press **OK**.

- 5 The Carriage Assembly test starts and the Front Panel displays the following messages followed by their results:

- Getting Part Number.
- Getting Scan Access size.
- Getting Vs Carriage Voltage.

- 6 The Front Panel then displays the Carriage Voltage (+Vs) test results.

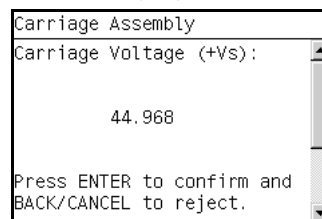

- 7 Press **OK** to accept the result. If the result is not correct use the **UP** or **Down** keys to select NO and press **OK**.

- 8 The Carriage Assembly Vaux test starts and the Front Panel displays:

- Getting Vaux Carriage Voltage.

- 9 The Front Panel then displays the Carriage Voltage (+Vaux) test results.

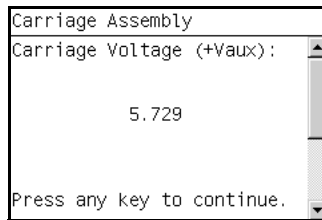

- 10 Press **OK** to accept the result. If the result is not correct use the **UP** or **Down** keys to select NO and press **OK**.
- 11 The Carriage Assembly UVC flag test starts and the Front Panel displays:
- Clearing UVC flag.
 - Reading UVC flag.
 - Checking UVC flag.
- 12 The Front Panel then displays the UVC flag test results.

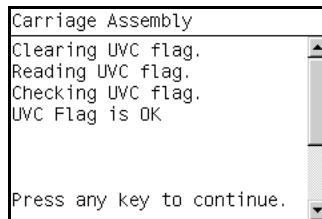

- 13 Press any key to continue.
- 14 The Carriage Assembly Pens Voltage test starts and the Front Panel displays:
- Getting Vpp.
- 15 The Front Panel then displays the Pens Voltage test results.

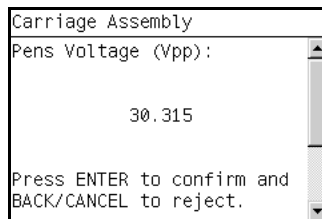

- 16 Press any key to continue.
- 17 The Carriage Assembly test continues and the Front Panel displays:
- Starting Line Sensor Leds.
 - Starting Light Sensor.
 - Starting Line Sensor.
 - Starting SVS Motor.
 - Starting Carriage Motor.
 - Moving SVS out of Sax.
 - Moving Carriage middle.
 - Initializing LineSensor.

- 18** The Front Panel then prompts you to load roll media.

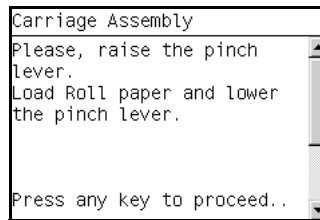

- 19** Load roll media.
- 20** Press any key to continue.
- 21** The Carriage Assembly test continues and the Front Panel displays the result of each phase of the test:
- Setting LS low intensity.
For each color LED: Blue, Green, Red, and Amber.
 - Setting LS max intensity.
For each color LED: Blue, Green, Red, and Amber
 - Checking Tolerance.
 - Starting NvmLineSensor.
 - Initializing NvmLineSensor.
 - Getting LS serial number.
 - Reading LS Nvm.
 - Writing new LS Nvm.
 - Checking LS serial number.
 - Starting Service Station.
 - Starting Scan Axis.
 - Moving SVS out of sax.
 - Homing Scan Axis.
 - Moving Carriage out of SVS.
 - Homing Service Station.
 - Starting Servicing Services.
 - Starting ColorSensor.
- 22** The Front Panel then prompts you to enable the Color Sensor (ESP).

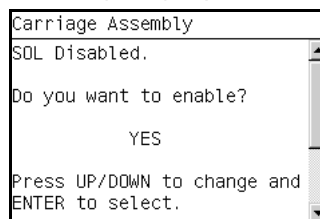

- 23** Press **OK** to enable the Color Sensor (ESP). If you do not wish to enable the Color Sensor (ESP) use the **UP** or **Down** keys to select **NO** and press **OK**.
- 24** The Color Sensor (ESP) enable test starts and the front Panel displays the following messages:
- Starting ColorSensor.

- Starting ColorSensing.
- Reading Color Sensor (ESP) status.
- Enabling Color Sensor (ESP).

- 25** The Front Panel then displays Color Sensor (ESP) enable test result and prompts you to press any key to continue.

```

Carriage Assembly
Starting ColorSensor.
Starting ColorSensing.
Reading SCL status.
Enabling SCL.
SCL enable/disable OK

Press any key to continue.

```

- 26** Press any key to continue.
- 27** The Front Panel then prompts you to confirm the Carriage Assembly information.

```

Carriage Assembly
FW Revision: V4.080D
Sensor Type: PP2
Serial Number: 169857308
Mfg date: 0622

YES.
Press ENTER to confirm and
BACK/CANCEL to reject.

```

- 28** Press **OK** to confirm the information. If you want to reject the information use the **UP** or **Down** keys to select **NO** and press **OK**.
- 29** The Carriage Assembly calibration test starts and the front Panel displays the following messages:
- Starting ColorSensor.
 - Starting ColorSensing.
 - Reading Color Sensor (ESP) status.
 - Reading registers.
 - Performing calibration.
- 30** The Front Panel then displays DeltaE test result and prompts you to press any key to continue.

```

Carriage Assembly
Maximum DeltaE: 2.560

Press any key to continue.

```

- 31** Press any key to continue.

- 32** The Carriage moves into the print path and the front Panel then prompts you to remove all pens.

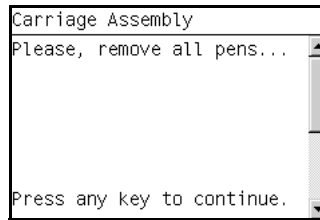

- 33** Open the Window.
34 Open the Carriage cover.
35 Remove all the Printheads from the Carriage.
36 Press any key to continue.
37 The Carriage Assembly pens test executes and checks the pens status.
38 The Front Panel then prompts you to replace all the Printheads.

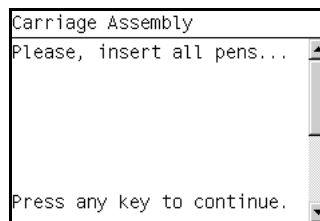

- 39** Replace all the Printheads.
40 Close the Carriage Cover.
41 Close the Window.
42 Press any key to continue.
43 The Carriage Assembly pens test continues and checks the pens status.
44 The Front Panel then displays the test result.

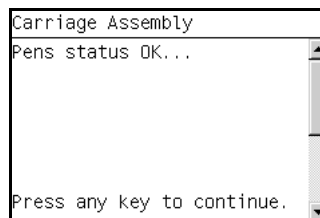

- 45** Press any key to continue.
46 The Encoder Manager test starts and the Front Panel displays the result of each phase of the test.

- 47** The Front Panel then displays Encoder Difference (Left/Right) test result and prompts you to press any key to finish.

```
Carriage Assembly
Encoder Difference
(Left/Right):

      8376 / 8352 eu

Press any key to finish.
```

- 48** Press any key to finish.

- 49** The Front Panel shows the test complete display for a few seconds.

```
Carriage Assembly

      00  K  K
      0 0  K K
      0 0  KK
      0 0  KK
      0 0  K K
      00  K  K
```

- 50** The Front Panel prompts you to shutdown the printer to complete the test.

```
Carriage Assembly
Press any key to shutdown
the system.
```

- 51** Press any key to shutdown the printer.

5. Sensors

The Sensors test diagnoses Failures of any sensors of the printer. Always run this test before replacing any of the following sensors:

- Window sensor.
- Media Lever position sensor.
- Media sensor

- 1 In the Diagnostics menu, scroll to **5. Sensors** and press **OK**.

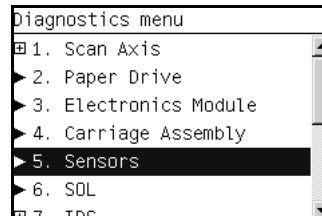

- 2 The Sensors test starts and the Front Panel prompts you to verify default sensor positions:

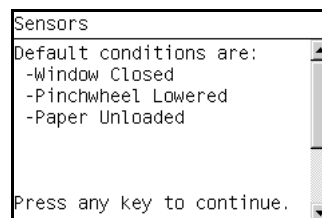

- 3 Verify that the sensors are in the default positions and any key to continue.
- 4 The Window sensor test starts and the Front Panel prompts you to open the Window:

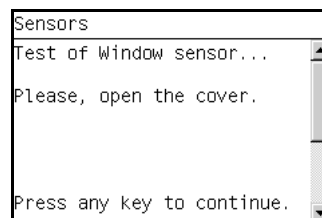

- 5 Open the Window.
- 6 Press any key to continue.
- 7 The Window sensor test continues and the Front Panel prompts you to close the Window:

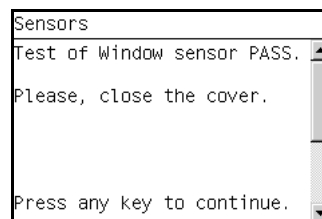

- 8 Close the Window.
- 9 Press any key to continue.

- 10** The Media Lever sensor test starts and the Front Panel prompts you to raise the Media Lever:

```
Sensors
Test of Pinchwheel Lever
sensor...
Please, raise the lever.
Press any key to continue.
```

- 11** Raise the Media Lever.
12 Press any key to continue.
13 The Media Lever sensor test continues and the Front Panel prompts you to lower the Media Lever:

```
Sensors
Test of Pinchwheel Lever
sensor PASS.
Please, lower the lever.
Press any key to continue.
```

- 14** Lower the Media Lever.
15 Press any key to continue.
16 The Media sensor test starts and the Front Panel prompts you load media:

```
Sensors
Test of Paper sensor...
Please, raise the lever,
load the paper and lower
the lever.
Press any key to continue.
```

- 17** Raise the Media Lever.
18 Load media.
19 Lower the Media Lever.
20 Press any key to continue.
21 The Media sensor test continues and the Front Panel prompts to remove media:

```
Sensors
Test of Paper sensor PASS.
Please, raise the lever,
remove the paper and lower
the lever.
Press any key to continue.
```

- 22** Raise the Media Lever.
23 Unload the media.
24 Lower the Media Lever.

- 25** Press any key to continue.
- 26** The Front Panel shows the test complete display for a few seconds.

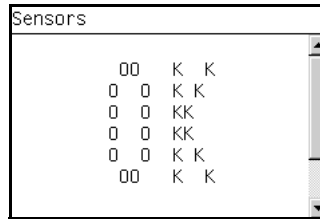

- 27** The Front Panel prompts you to shutdown the printer to complete the test.

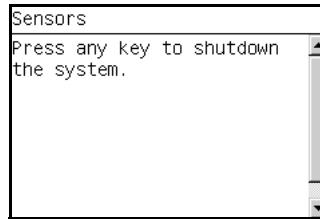

- 28** Press any key to shutdown the printer.

6. Color Sensor (ESP)

The Color Sensor (ESP) test diagnoses Failures of the Color Sensor located on the carriage. Always run this test before replacing the Color sensor:

- 1 In the Diagnostics menu, scroll to **6. Color Sensor (ESP)** and press **OK**.

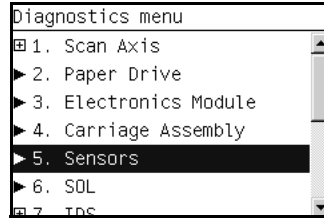

- 2 The Color Sensor (ESP) test starts and the front Panel displays the following messages:

- Starting Horburgh.
- Starting Carriage.
- Starting Nvm.
- Getting Part Number.
- Getting Scan Axis size.
- Starting Service Station.
- Starting Scan Axis.
- Moving SVS out of Sax.
- Homing Scan Axis.
- Moving Carriage out of SVS.
- Homing Service Station.
- Starting Servicing Services.
- Capping Service Station.
- Starting ColorSensor.

- 3 The Front Panel then prompts you to enable the Color Sensor (ESP).

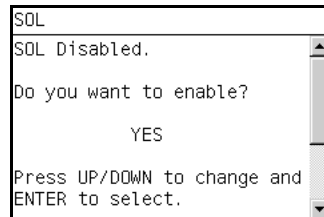

- 4 Press **OK** to enable the Color Sensor (ESP). If you do not wish to enable the Color Sensor (ESP) use the **UP** or **Down** keys to select NO and press **OK**.

- 5 The Color Sensor (ESP) enable test starts and the front Panel displays the following messages:

- Starting ColorSensor.
- Starting ColorSensing.
- Reading Color Sensor (ESP) status.
- Enabling Color Sensor (ESP).

- 6** The Front Panel then displays Color Sensor (ESP) enable test result and prompts you to press any key to continue.

```

SQL
Starting ColorSensor.
Starting ColorSensing.
Reading SQL status.
Enabling SQL.
SQL enable/disable OK

Press any key to continue.
    
```

- 7** Press any key to continue.
- 8** The Front Panel then displays the Color Sensor (ESP) details and prompts you to press any key to continue.

```

SQL
FW Revision: V4.080D
Sensor Type: PP2
Serial Number: 169857228
Mfg date: 0622

YES.
Press ENTER to confirm and
BACK/CANCEL to reject.
    
```

- 9** The Front Panel then prompts you load media:

```

SQL
Please, raise the pinch
lever.
Load Roll paper and lower
the pinch lever.

Press any key to proceed.
    
```

- 10** Raise the Media Lever.
- 11** Load media.
- 12** Lower the Media Lever.
- 13** Press any key to continue.
- 14** The Front Panel then displays the DeltaE test result and prompts you to press any key to continue.

```

SQL
Maximum DeltaE: 2.735

Press any key to continue.
    
```

- 15** Press any key to continue.

- 16** The Front Panel shows the test complete display for a few seconds.

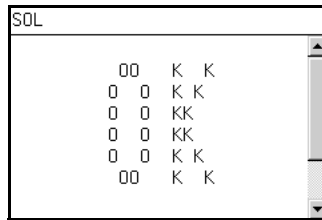

- 17** The Front Panel prompts you to shutdown the printer to complete the test.

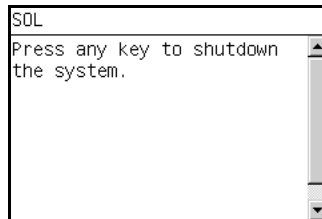

- 18** Press any key to shutdown the printer.

Color Sensor (ESP) System Error Codes

The following table lists the possible Error Codes that could be encountered during the test:

7. Ink Delivery System (IDS)

The complete Ink Delivery System test consists of individual tests for the different components related to this subsystem. These tests are:

- Ink Delivery System
- Check Ink Supplies

Ink Delivery System

- 1 In the Diagnostics menu, scroll to **7. IDS** and press **OK**.

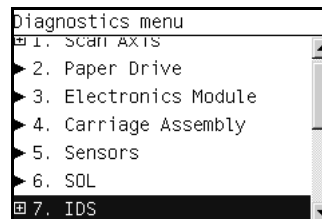

- 2 The Front Panel will show the **7. IDS** submenu.

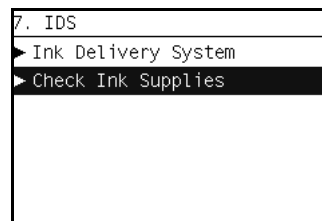

- 3 In the **IDS** submenu, scroll to **Ink Delivery System** and press **OK** to start the test.
- 4 The Ink Delivery System test starts and the front Panel prompts you to remove all the Ink Supplies.

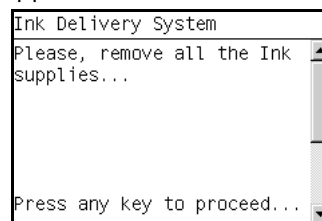

- 5 Remove all the Ink Cartridges.
- 6 Press **OK** to continue.
- 7 The test continues and the front Panel displays the following messages:
 - Starting Horsburgh.
 - Starting Mips.
 - Starting Nvm.
 - Getting Part Number.
 - Starting ISS Motors.
 - Moving Bongos down.
 - Reading Bongos down.
 - Moving Bongos up.
 - Reading Bongos up.

- Starting OutOfInk sensors.
- Reading OutOfInk.

8 The Front Panel then prompts you push down Bongo0.

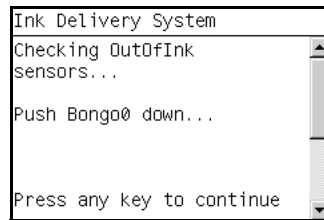

9 Press and hold down Bongo0 which is located at the furthest left Ink Cartridge position.

10 Press any key.

11 Release Bongo0.

12 Press any key.

13 The Front Panel then displays the Bongo0 test results.

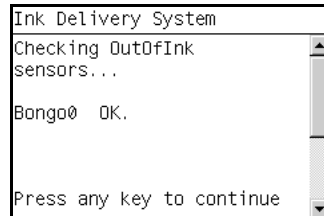

14 Press any key.

15 Repeat steps 8 through 14 for the remaining Out of Ink sensors for each of the Ink Cartridges.

16 The front Panel prompts you to insert all the Ink Supplies.

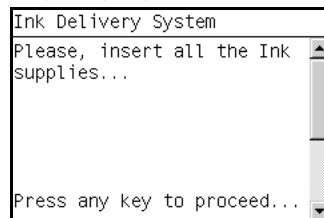

17 Install all the Ink Cartridges.

18 Press **OK** to continue.

19 The Acumen Supplies test and the front Panel displays the following messages:

- Starting AcumenSupplies.
- Reading AcumenSupplies.

- 20** The Front Panel then displays Acumen Supplies test results.

```

Ink Delivery System
Starting AcumenSupplies.
Reading Acumen Supplies.

Acumen Supplies OK.

Press any key to finish.
    
```

- 21** The Front Panel shows the test complete display for a few seconds.

```

Ink Delivery System

      00  K  K
      0 0  K K
      0 0  KK
      0 0  KK
      0 0  K K
      00  K  K
    
```

- 22** The Front Panel prompts you to shutdown the printer to complete the test.

```

Ink Delivery System
Press any key to shutdown
the system.
    
```

- 23** Press any key to shutdown the printer.

Check Ink Supplies

- 1** In the Diagnostics menu, scroll to **7. IDS** and press **OK**.

```

Diagnostics menu
 1. SCAN AXIS
 2. Paper Drive
 3. Electronics Module
 4. Carriage Assembly
 5. Sensors
 6. SQL
 7. IDS
    
```

- 2** The Front Panel will show the **7. IDS** submenu.

```

7. IDS
  Ink Delivery System
  Check Ink Supplies
    
```

- 3** In the **IDS** submenu, scroll to **Check Ink Supplies** and press **OK** to start the test.
- 4** The Check Ink Supplies test starts and the front Panel displays the following messages:
- Starting Horburgh & Mips.
 - Starting Nvm.

- Getting Part Number.
- Starting Supplies.
- Starting AcumenSupplies.
- Reading Ink Supplies.

5 The Front Panel then displays Check Ink Supplies test results.

```
SOL
Starting ColorSensor.
Starting ColorSensing.
Reading SOL status.
Enabling SOL.
SOL enable/disable OK

Press any key to continue.
```

6 Press **OK** to exit.

7 The Front Panel shows the test complete display for a few seconds.

```
Check Ink Supplies

  00  K  K
 0 0  K K
 0 0  KK
 0 0  KK
 0 0  K K
 00  K  K
```

8 The Front Panel prompts you to shutdown the printer to complete the test.

```
Check Ink Supplies
Press any key to shutdown
the system.
```

9 Press any key to shutdown the printer.

8. Service Station

The complete Service Station test consists of individual tests for the different components related to this subsystem. These tests are:

- Service Station
- Primer Motor
- Aerosol Fan

Service Station

- 1 In the Diagnostics menu, scroll to **8. Service Station** and press **OK**.

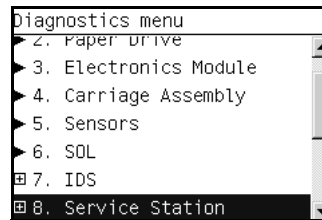

- 2 The Front Panel will show the **8. Service Station** submenu.

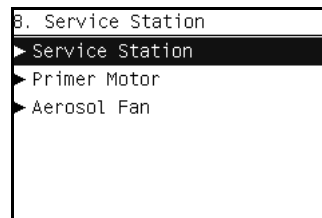

- 3 In the **8. Service Station** submenu, scroll to **Service Station** and press **OK** to start the test.
- 4 The Service Station test starts and the front Panel displays the following messages:
 - Starting Horsburgh.
 - Booting up Carriage.
 - Starting SVS Motor.
 - Starting Nvm.
 - Getting Part Number.
 - Starting Service Station.
 - Starting Scan Axis.
 - Moving SVS out of Sax.
 - Homing Scan Axis.
 - Moving Carriage out of SVS.
 - Homing Service Station.
 - Moving to Spit Rear pos.
 - Moving to Spit Front pos.
 - Moving to Wipe forward pos.
 - Moving to Wipe reverse pos.
 - Moving to Cleaner pos.
 - Moving to Color Sensor (ESP) pos.
 - Homing Scan Axis.

- Starting ServicingServices.
- Capping Service Station.
- Uncapping Service Station.
- Starting Mechanical Init.

5 The front Panel then prompts you to check the status of the printe.

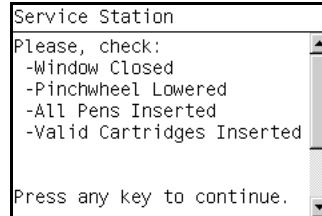

6 Check that:

- The Window is closed.
- The Media Lever is lowered.
- All Printheads are inserted.
- Valid Cartridges are inserted.

7 Press **OK** to continue.

8 The Front Panel then displays test results.

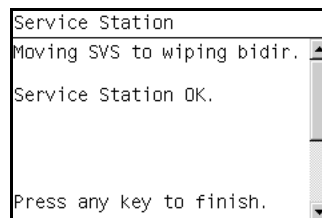

9 The Front Panel shows the test complete display for a few seconds.

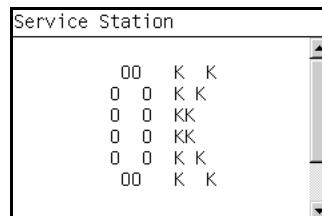

10 The Front Panel prompts you to shutdown the printer to complete the test.

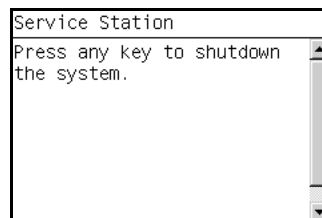

11 Press any key to shutdown the printer.

Primer Motor

- 1 In the Diagnostics menu, scroll to **8. Service Station** and press **OK**.

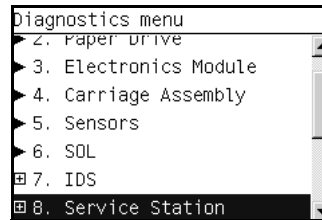

- 2 The Front Panel will show the **8. Service Station** submenu.

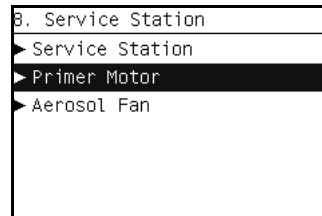

- 3 In the **8. Service Station** submenu, scroll to **Primer Motor** and press **OK** to start the test.
- 4 The Primer Motor test starts and the front Panel displays the following messages:
 - Starting Horsburgh.
 - Booting up Carriage.
 - Starting SVS Motor.
 - Starting Nvm.
 - Getting Part Number.
 - Starting Service Station.
 - Starting Scan Axis.
 - Moving SVS out of Sax.
 - Homing Scan Axis.
 - Moving Carriage out of SVS.
 - Homing Service Station.
 - Moving to Spit Rear pos.
 - Moving to Spit Front pos.
 - Moving to Wipe forward pos.
 - Moving to Wipe reverse pos.
 - Moving to Cleaner pos.
 - Moving to Color Sensor (ESP) pos.
 - Homing Scan Axis.
 - Starting ServicingServices.
 - Capping Service Station.
 - Uncapping Service Station.
 - Starting Mechanical Init.

- 5 The front Panel then prompts you to check the status of the printe.

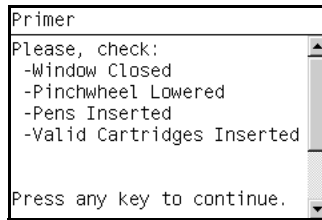

- 6 Check that:
- The Window is closed.
 - The Media Lever is lowered.
 - All Printheads are inserted.
 - Valid Cartridges are inserted.

- 7 Press **OK** to continue.

- 8 The Primer Motor test continues and the Front Panel shows the progress of the test.

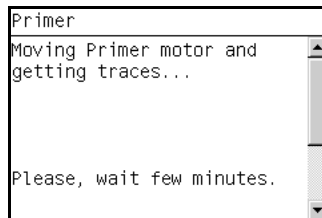

- 9 The Front Panel shows the test complete display for a few seconds.

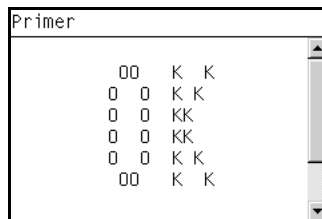

- 10 The Front Panel prompts you to shutdown the printer to complete the test.

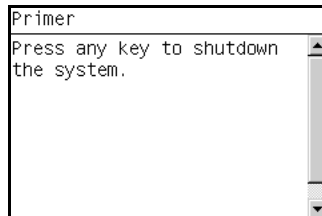

- 11 Press any key to shutdown the printer.

Aerosol Fan

- 1 In the Diagnostics menu, scroll to **8. Service Station** and press **OK**.

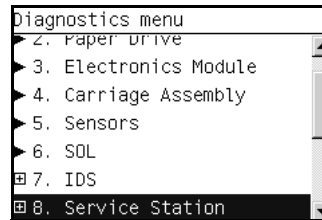

- 2 The Front Panel will show the **8. Service Station** submenu.

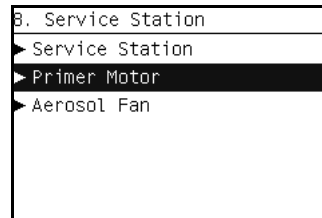

- 3 In the **8. Service Station** submenu, scroll to **Aerosol Fan** and press **OK** to start the test.
- 4 The Primer Motor test starts and the front Panel displays the following messages:
 - Starting Horsburgh.
 - Booting TestsGpio.
 - Starting Nvm.
- 5 The front Panel then prompts you switch on the Aerosol Fan.

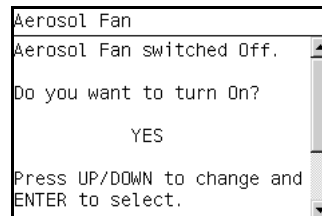

- 6 Press **OK** to the switch on the Aerosol Fan. If you do not wish to switch on the Aerosol Fan use the **UP** or **Down** keys to select **NO** and press **OK**.
- 7 The test continues and the Front Panel displays the results.

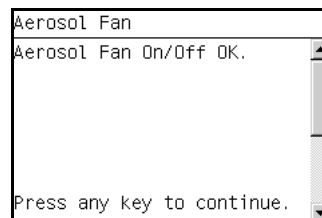

- 8 Press any key to continue.

- 9 The front panel prompts you to check if the Aerosol Fan is operating.

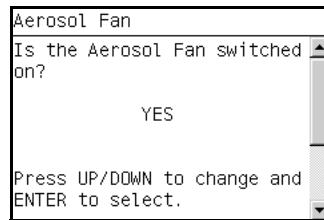

- 10 Listen carefully to check if the Aerosol Fan is operating.
- 11 If it is operating, use the **UP** or **Down** keys to select YES and press **OK**. If it is NOT operating, select NO and press **OK**.
- 12 The Front Panel shows the test result.

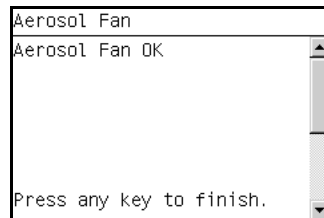

- 13 Press any key to finish.
- 14 The Front Panel shows the test complete display for a few seconds.

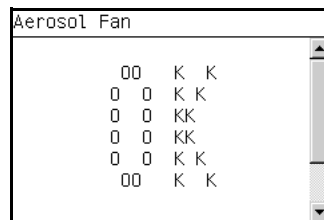

- 15 The Front Panel prompts you to shutdown the printer to complete the test.

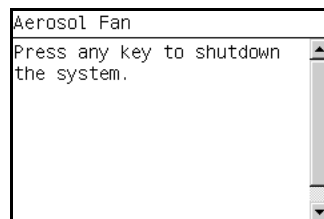

- 16 Press any key to shutdown the printer.

9. I/O Information

The I/O Information test retrieves the TC/IP Network configuration parameters from the printer.

- 1 In the Diagnostics menu, scroll to **9. I/O Information** and press **OK**.

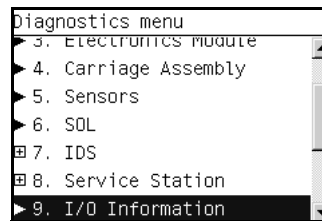

- 2 The I/O Information test starts and the front Panel displays the following message:

- Getting IO Interface.
- Starting ColorSensor.

- 3 The Front Panel displays the I/O Information.

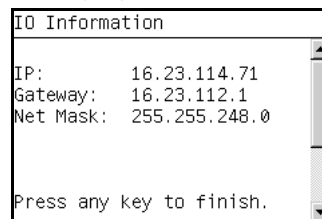

- 4 Press any key to finish.
- 5 The Front Panel shows the test complete display for a few seconds.

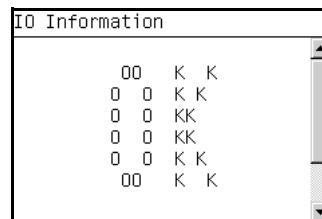

- 6 The Front Panel prompts you to shutdown the printer to complete the test.

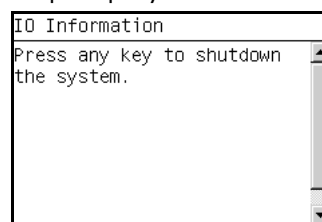

- 7 Press any key to shutdown the printer.

10. Unit Information

- 1 The Unit Info test recovers the Firmware Version, Serial Number and Part Number of the printer.
- 2 In the Diagnostics menu, scroll to **10 Unit Info** and press **OK**.

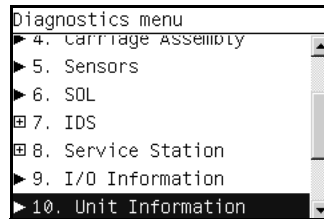

- 3 The Unit Information test starts and the front Panel displays the following message:
 - Starting Horsburgh.
 - Starting Nvm.
 - Getting FW version.
 - Getting Serial,
 - Getting Part Number.
- 4 The Front Panel shows the result of the test.

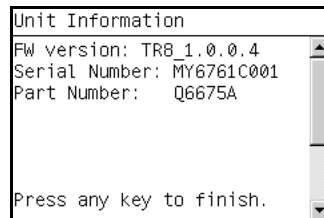

- 5 Press any key to continue.
- 6 The Front Panel shows the test complete display for a few seconds.

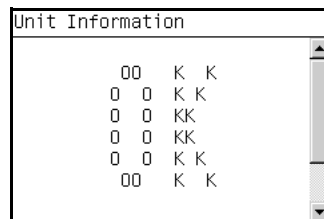

- 7 The Front Panel prompts you to shutdown the printer to complete the test.

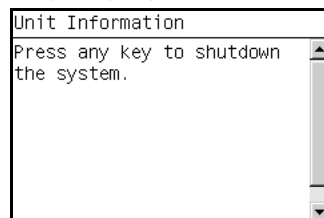

- 8 Press any key to shutdown the printer.

11. EEROM Reset

The EEROM Reset test resets the printer to the factory defaults and delete any user information/files.

- 1 In the Diagnostics menu, scroll to **11. EEROM** and press **OK**.

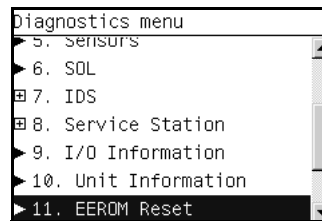

- 2 The EEROM Reset test starts and the front Panel prompts you to request if you want to continue.

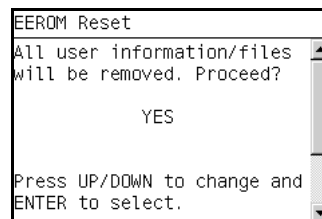

- 3 If you do want to continue the test, use the **UP** or **Down** keys to select YES and press **OK**. If you do NOT want to continue, select NO and press **OK**.
- 4 The EEROM Reset test continues and the front Panel displays the following message:
 - Starting Horsburgh.
 - Starting Nvm.
 - Getting Part Number.
 - Setting default config.
- 5 The Front Panel shows the result of the test.

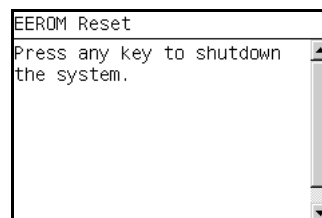

- 6 Press any key to continue.
- 7 The Front Panel warns you that you will have to calibrate the printheads after rebooting the printer.

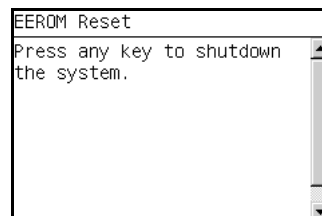

- 8 Press any key to continue.

- 9** The Front Panel shows the test complete display for a few seconds.

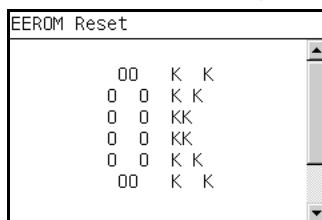

- 10** The Front Panel prompts you to shutdown the printer to complete the test.

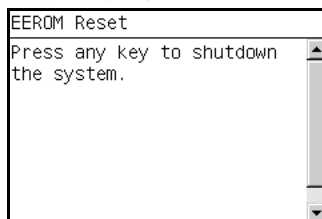

- 11** Press any key to shutdown the printer.

12. Set Unit Configuration

The purpose of this test is to automatically configure the Printer either as Standard or Productivity.

- 1** In the Diagnostics menu, scroll to **12. Set Unit Configuration** and press **OK**.
- 2** The Set Unit Configuration test starts and the front Panel prompts you to request if you want to continue.
- 3** If you do want to continue the test, use the **UP** or **Down** keys to select YES and press **OK**. If you do NOT want to continue, select NO and press **OK**.
- 4** The Set Unit Configuration continues and the front Panel displays the several messages.
- 5** The Front Panel shows the result of the test.
- 6** Press any key to continue.
- 7** The Front Panel shows the test complete display for a few seconds.
- 8** The Front Panel prompts you to shutdown the printer to complete the test.
- 9** Press any key to shutdown the printer.

13. Error 71:19 Recovery

This diagnostic test utility is used to set the Serial Number and Part Number if either the Formatter or the Printmech PCA or both have been replaced.

The complete Error 71:19 Recovery utility consists of individual utilities to handle different serial and part number setting requirements. These tests are:

- Set Serial Number
- Select Right S/N

Set Serial Number

The purpose of this utility is to set the Serial Number and Part Number in case both the Formatter and the Printmech PCA are replaced at the same time.

Set the Serial Number as follows:

- 1 In the Diagnostics menu, scroll to **13. Error 71:19 Recovery** and press **OK**.

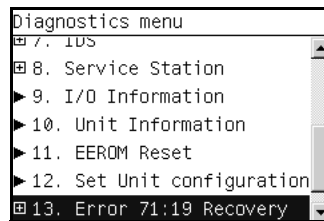

- 2 The Front Panel will show the **13. Error 71:19 Recovery** submenu.

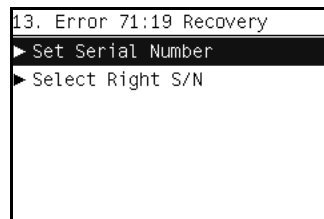

- 3 In the **13. Error 71:19 Recovery** submenu, scroll to **Set Serial Number** and press **OK** to start the test.
- 4 The Set Serial Number test starts and the front Panel displays the following messages:
 - Checking SE Log.
 - Starting Horsburgh & Mips.
 - Starting NvmBackup.
 - Starting NvmMain
 - Getting Serial Number
 - Checking Serial Number.
 - Starting Nvm.
 - Getting Part Number.
 - Setting default config.

- 5 The Front Panel prompts you to enter the Serial Number.

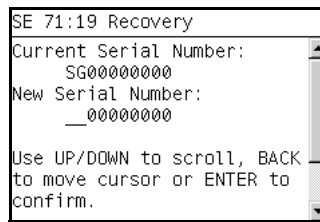

- 6 Use the UP, DOWN and BACK keys to select each character of the Serial Number and use the OK to confirm.
- 7 The Front Panel shows the test complete display for a few seconds.

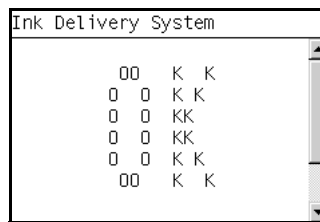

- 8 The Front Panel prompts you to shutdown the printer to complete the test.

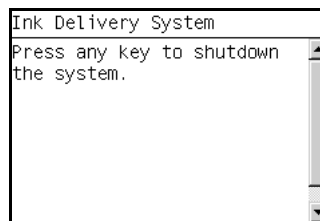

- 9 Press any key to shutdown the printer.

Select Right S/N

The purpose of this utility is to set the correct Serial Number and Part Number in case either the Formatter or the Printmech PCA have been replaced.

Set the correct Serial Number as follows:

- 1 In the Diagnostics menu, scroll to **13. Error 71:19 Recovery** and press **OK**.

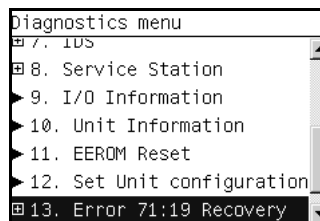

- 2 The Front Panel will show the **13. Error 71:19 Recovery** submenu.

- 3** In the **13. Error 71:19 Recovery** submenu, scroll to **Select Right S/N** and press **OK** to start the test.

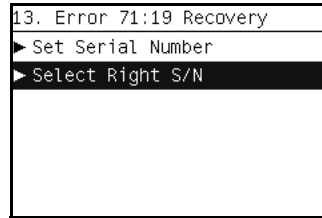

- 4** The Select Right S/N test starts and the front Panel displays the following message:

- Checking SE Log.
- Starting Horsburgh.
- Starting NvmMain
- Starting NvmBackup.
- Getting Serial Number.

- 5** The Front Panel prompts choose the correct Serial Number and Part Number.

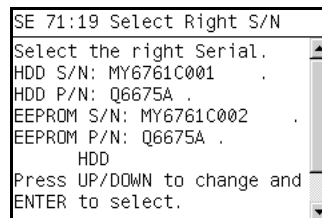

- 6** Use the UP and DOWN keys to select the location containing the correct Serial and Part Number, HDD for the Formatter or EEPROM for the PrintMech PCA.

- 7** Press OK to confirm your choice.

- 8** The Select Right S/N test continues and the front Panel displays the following messages as the correct Serial Number and Part Number are copied from the selected location to the other memory location:

- Starting NvmMain
- Starting NvmBackup.
- Getting Serial Number.
- Checking Serial Number.
- Getting Part Number.
- Writing the right S/N.

- 9** The Front Panel shows the test complete display for a few seconds.

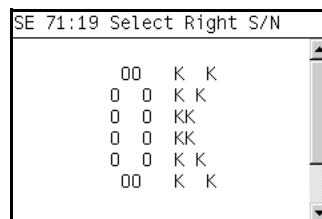

- 10** The Front Panel prompts you to shutdown the printer to complete the test.

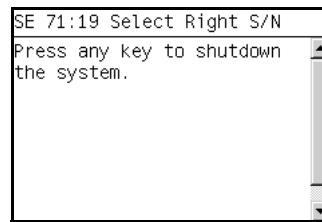

- 11** Press any key to shutdown the printer.

14. Others

This test is not implemented for the current version of the printer.

Service Utilities

The following is a list of all internal Service Utilities available in the Printers. Instructions for entering the Service Utilities menu are given on Page 4-57.

- 1** Turn Drive Roller ⇒ Page 4-59
The purpose of this Service Utility is to rotate the Drive Roller and the Overdrive in order to clean them.
- 2** Prime Tubes ⇒ Page 4-61
The purpose of this Service Utility is to Prime the Tubes when the Ink Tubes are NOT new and they need to be re-primed or automatic priming was not completed correctly.
- 3** Set SN ⇒ Page 4-64
The purpose of this Service Utility is to set the Serial Number of the Printer.
- 4** Reset Life Counters ⇒ Page 4-65
The purpose of this Service Utility is to reset the internal life counters. There are two submenus that allow you to:
 - Reset ALL the counters related to a Preventive Maintenance Kit (PMK).
 - Reset only the counters related to a specific replaced part.
- 5** Diagnostic Print ⇒ Page 4-67
The purpose of this Service Utility is to print the Diagnostic Print in order to identify image quality problems.
- 6** Set Time and Date ⇒ Page 4-68
The purpose of this Service Utility is to set the Real Time Clock (RTC) of the Printer.
- 7** Enable/Disable Firewall ⇒ Page 4-69
The purpose of this Service Utility is to enable or disable the built-in system firewall.

Entering the Service Utilities Menu

- 1 Once the message "Ready" or "Ready for paper" is displayed on the front-panel, press the **Menu** key.



- 2 For Call Agents who will request the user to perform certain Service Utilities, once inside the "Main Menu", press the **Down** arrow key and the **Cancel** key together. You are now in the **Service Tools** Menu.



- 3 For On-Site Engineers, once inside the "Main Menu", press the **Up** arrow key and the **Cancel** key together. You are now in the **Service Menu** Menu.



- 4 Use the **Arrow** keys to scroll to the “Service Utilities” menu option and press the **OK** key.

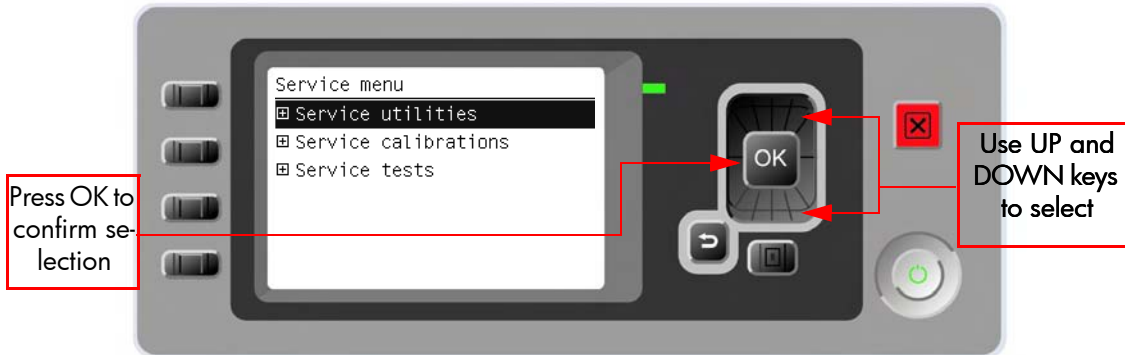

- 5 Use the **Arrow** keys to scroll through the “Service Utilities” selections and press the **OK** key to begin a specific operation when the required Service Utility is highlighted.

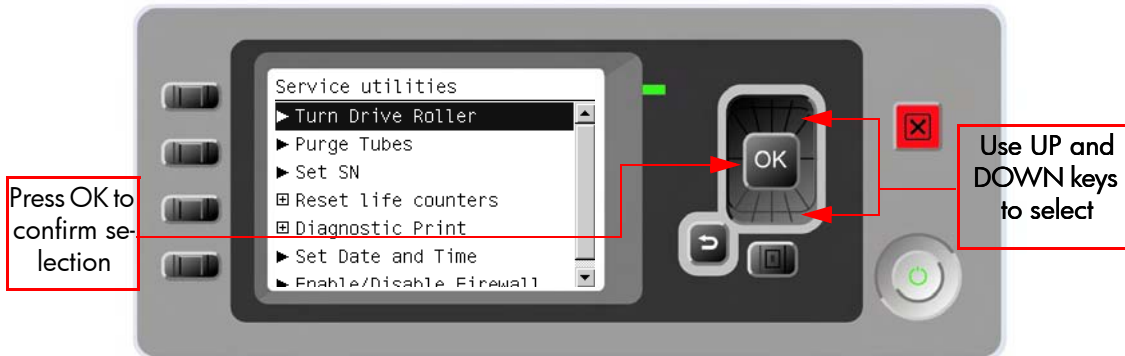

If the printer is not used for 135 seconds, the printer exits out of the Service Utilities Menu and you must repeat the above steps to enter Service Utilities again.

In some cases a quick press of a button may not be recognized by the Printer. When pressing a button, be sure to press it deliberately and all the way to the bottom of its travel.

1. Turn Drive Roller

The purpose of this Service Utility is to rotate the Drive Roller and the Overdrive in order to clean them.

REMOVE THE MEDIA BEFORE PERFORMING THIS OPERATION.

OPEN THE WINDOW OF THE PRINTER AND ACTIVATE THE WINDOW SENSOR (USING A PIECE OF PAPER) BEFORE PERFORMING THIS SERVICE UTILITY.

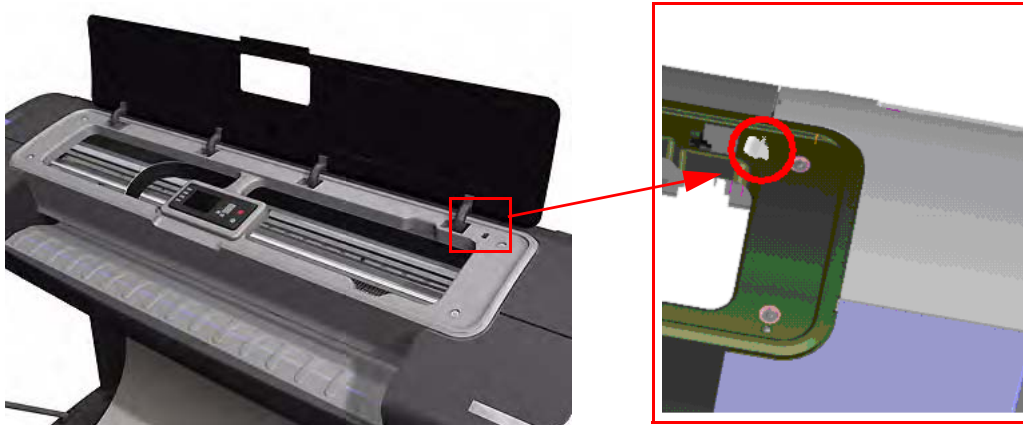

Perform the Turn Drive Roller utility as follows:

- 1 In the Service Utilities submenu, scroll to **Turn Drive Roller** and press **OK**.

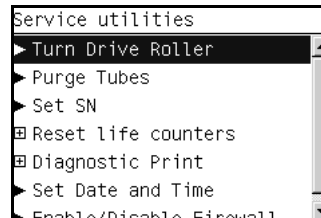

- 2 The Printer checks to see if media is loaded and the Front panel displays the following message. If media is loaded, the Front Panel will display a message. Unload the media and start again from **step 1**:

- Checking Media Presence Sensor

- 3 The Drive Roller begins to turn slowly and the following message is displayed on the Front Panel:

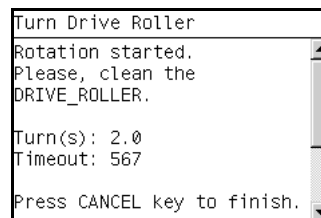

- 4 Refer to the Cleaning Instructions on Page 9-3.
- 5 Once you have finished cleaning the Drive Roller and the Overdrive, press the **Cancel** key to finish the utility.
- 6 If the utility exits correctly, OK will be displayed on the Front Panel.

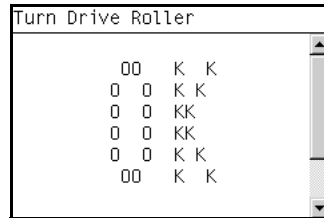

PLEASE REMEMBER TO REMOVE THE PIECE OF PAPER FROM THE WINDOW SENSOR BEFORE CLOSING THE WINDOW AS THIS COULD DAMAGE THE WINDOW AND THE SENSOR.

2. Purge Tubes

The purpose of this Service Utility is to Prime the Tubes when the Ink Tubes are NOT new and they need to be re-primed or automatic priming was not completed correctly.

Make sure that NEW Ink Cartridges are installed or that the ink volume remaining in the Ink cartridges is below 88% before starting to prime the tubes. If you do not comply, you will get a warning message.

Perform the Prime Tubes utility as follows:

- 1 In the Service Utilities submenu, scroll to Purge Tubes and press **OK**.

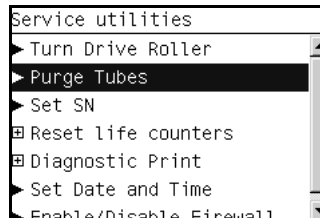

- 2 When the front panel prompts you to reboot the system, you must select whether you would like to continue with the procedure by pressing the **Enter** key, in which case the Printer will reboot. Press **Back** or **Cancel** to exit the procedure at this point.
- 3 The Front Panel displays a message to say the Printer is going to reboot.

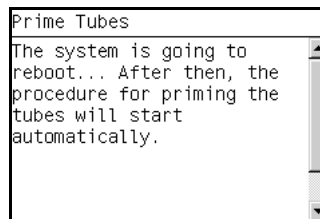

- 4 Once the Printer has rebooted, the Front Panel will instruct you to open the Window and remove ALL the Printheads installed in the Carriage.

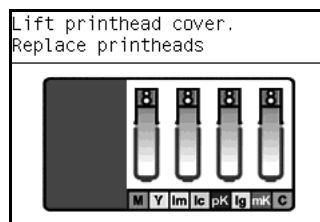

- 5 Once ALL the Printheads have been removed, the Front Panel will instruct you to install the Setup Printheads into the Carriage.

- 6** Install the Setup Printheads in the carriage.

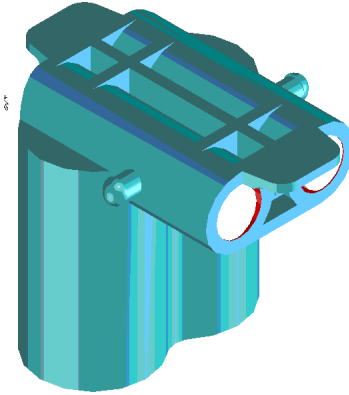

- 7** Once all the Setup Printheads are installed, the following message will appear on the front panel. Close the carriage cover and close the window.

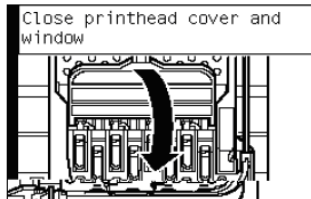

- 8** The printer will begin to purge the tubes system.
9 Once the tubes system has been purged, the following message will instruct you to open the Window:

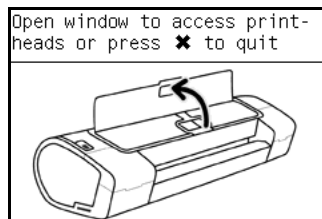

- 10** When the following message appears on the Front Panel, open the Carriage cover and check the window on top of each Setup Printhead. If the Ink Supply Tubes have been primed correctly, the windows will contain ink. If the windows on top of each Setup Printhead does NOT contain ink, then you may need to repeat the Prime Tubes process from the beginning.

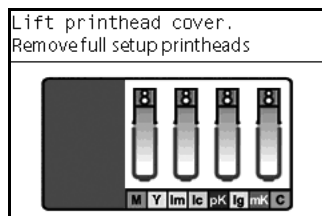

- 11** Remove ALL the Setup Printheads from the Carriage and install the previously removed Printheads.

- 12** Once ALL the Printheads are installed, the Front Panel will instruct you to close the Carriage cover and close the Window.

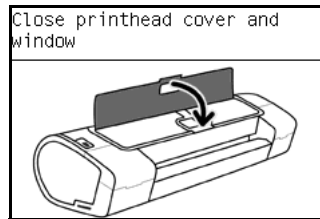

- 13** The Printer will now perform the Printhead Alignment and Front Panel will prompt you to continue with the Printhead Alignment, select **Align now** and press the **OK** key.
- 14** Once the Printhead Alignment is completed, the following message will be displayed on the Front Panel. Press the **OK** key to continue.

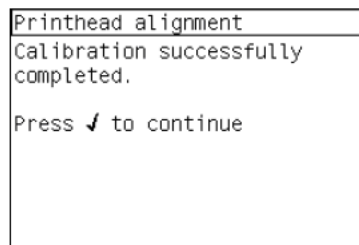

3. Set SN

The purpose of this Service Utility is to set the Serial Number of the Printer. Perform the Set SN utility as follows:

- 1 In the Service Utilities submenu, scroll to **Set SN** and press **OK**.

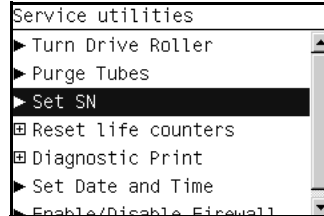

- 2 The Printer will display the current Serial Number and the new Serial Number of the Printer. Use the **Up** and **Down** keys to go through the digits and press the **OK** key to go to the next digit. You can press the **Cancel** key at any time to exit the utility without making any changes.

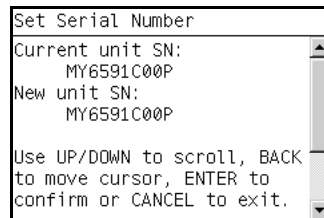

If the Serial Number or the Part Number cannot be read, the Front Panel will display the relevant System Error code.

- 3 Once the new Serial Number has been entered, the Front Panel will display the Serial Number and Model Number of the Printer. Press the **Enter** key to confirm the Serial Number or the **Cancel** key to exit the utility without making any changes or the **Back** key to modify again.
- 4 If the new Serial Number cannot be set, the Front Panel will display **System Error Code 74:00**.
- 5 If the utility exits correctly, OK will be displayed on the Front Panel.
- 6 When the printer is restarted after a serial number change an NVM setting sequence is initiated to synchronize the serial number stored in the backup memory.

4. Reset Life Counters

The purpose of this Service Utility is to reset the internal life counters. There are two submenus that allow you to:

- Reset ALL the counters related to a Preventive Maintenance Kit (PMK).
- Reset only the counters related to a specific replaced part.

ALWAYS RESET THE LIFE COUNTER OF A CORRESPONDING PART AFTER REPLACING IT.

Perform the Reset Life Counters utility as follows:

- 1 In the Service Utilities submenu, scroll to **Reset Life Counters** and press **OK**.

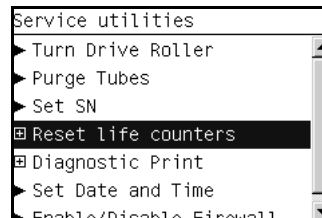

- 2 You will be given an option to either reset the Life Counter for ALL the parts related to a Preventive Maintenance Kit (PMK) or to just reset the Life Counter for a particular part:

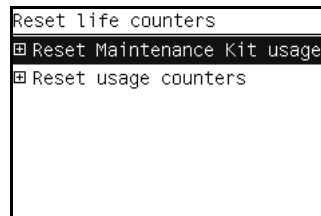

- a If you select to reset the Life Counter for ALL the parts related to a Preventive Maintenance Kit (PMK), you will be given an option to reset the Life Counter of:

The counters that are reset are show Preventive Maintenance ⇒ Page 4-25.

It is also advisable to check the status of the Life Counters related to the other Preventive Maintenance Kits to avoid multiple trips to the customer.

- Preventive Maintenance Kit 1 (PMK1).
 - Preventive Maintenance Kit 2 (PMK2).
- b If you select to reset the Life Counter for a particular part, you will be given an option to reset the Life Counter of the:
 - Trailing Cable and Tubes.
 - Scan-Axis Belt
 - Scan Motor.
 - Left Spittoon.

- Right Spittoon.
 - Full Bleed Foams.
 - Aerosol Fans
 - Carriage.
 - Service Station.
- 3** Once you have selected a Life Counter to reset, the following message will be displayed on the Front Panel. Press the **OK** key to reset the selected Life Counter or press **Back/Cancel** to exit without resetting the Life Counter.

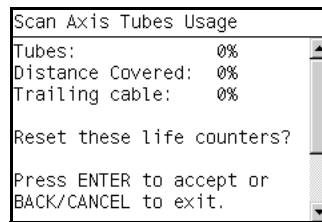

- If the Usage Counter information cannot be read, the Front Panel will display "Unable to get usage counter". This could point to a possible Firmware error.
- 4** If the utility exits correctly, OK will be displayed on the Front Panel.

5. Diagnostic Print

The purpose of this Service Utility is to print the Diagnostic Print in order to identify image quality problems.

Print the Diagnostic Print as follows:

- 1 In the Service Utilities submenu, scroll to **Diagnostic Print** and press **OK**.

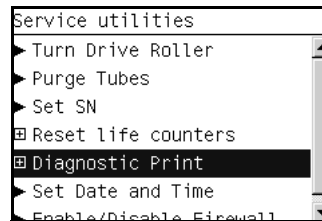

- 2 You will be given an option to print the:
 - Image Quality Service Best.
 - Image Quality Service Normal.
 - Advanced Diagnostic Print.
- 3 Use the **Arrow** keys to make the selection and press the **OK** key to start printing the required Diagnostic Print.

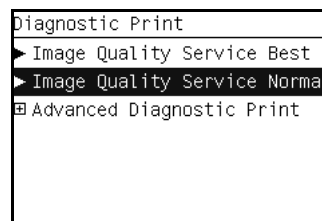

- 4 Make sure media is loaded, the Pinch Lever is lowered and that the Ink System is correctly installed. Press the **Enter** key to print the Diagnostic Print or press **Back/Cancel** to exit without printing the Diagnostic Print.

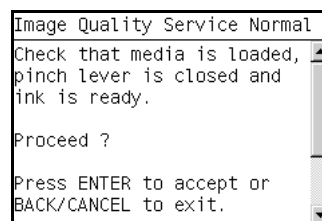

- 5 The selected Diagnostic Print will now be printed. For further information on how to use troubleshoot Image Quality problems, refer to Chapter 6.

6. Set Date and Time

The purpose of this Service Utility is to set the internal clock of the Printer.

Perform the Set Date and Time utility as follows:

- 1 In the Service Utilities submenu, scroll to **Set Date and Time** and press **OK**.

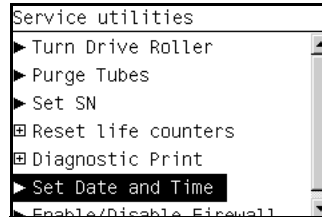

- 2 The Printer will display the current time and the new time. Use the **Up** and **Down** keys to go through the digits and press the **OK** key to go to the next digit. You can press the **Cancel** key at any time to exit the utility without making any changes.

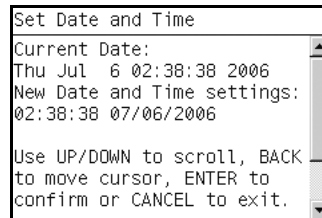

- 3 Once the new time has been entered, the Front Panel will prompt you to shut down the printer.

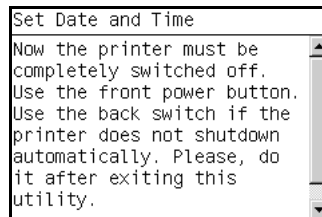

If the current RTC Clock cannot be set, it could point to a possible Firmware error.

- 4 Restart the printer.

7. Enable/Disable Firewall

The purpose of this Service Utility is to enable or disable the system firewall.

Perform the Enable/Disable Firewall utility as follows:

- 1 In the Service Utilities submenu, scroll to **Enable/Disable Firewall** and press **OK**.

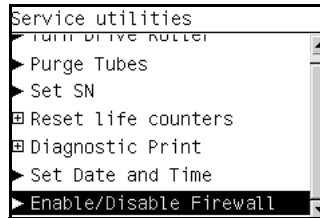

- 2 The utility checks to see if the firewall is enabled or disabled and the Front panel displays the following message:
 - Getting Information of Firewall.
- 3 When the following message appears on the front panel, you must select whether you would like to enable or disable the firewall. Use the **Up** and **Down** keys to make your selection and press the **OK** key.

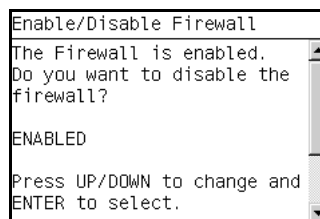

- 4 The system upgrades the internal memory to reflect the chosen selection.

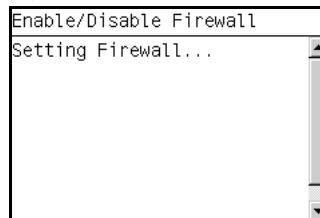

Service Calibrations

5

- Service Calibrations 5-2
- Scan Axis Calibration 5-5
- Service Station Calibration 5-6
- Paper Advance Calibration 5-7
- Drop Detector Calibration 5-12
- Line Sensor Calibration 5-14
- Carriage PCA 5-17
- Color Sensor (ESP) Calibration 5-18

Service Calibrations

The Printer has several calibration procedures that must be performed under certain conditions.

REMEMBER THAT CERTAIN CALIBRATIONS ARE REQUIRED EVEN IF AN ASSEMBLY HAS BEEN DISASSEMBLED TO GAIN ACCESS TO ANOTHER ASSEMBLY OR COMPONENT.

The following is a list of all internal service calibrations available in the Printers. Instructions for entering the service calibrations menu are given on Page 5-3.

1. Scan Axis Calibration ⇒ Page 5-5

The purpose of this Service Calibration is to carry out a PWM check, and calibrate the intensity of the Line Sensor.

2. Service Station Calibration ⇒ Page 5-6

The purpose of this Service Calibration is to calibrate the Drop Detector (located in the Service Station) in relation to the Carriage Assembly.

3. Paper Advance Calibration ⇒ Page 5-7

The purpose of this Service Calibration is to calibrate the nominal advance of the media. This calibration is necessary to control the exact movement of the media in order to avoid print quality problems like banding.

4. Drop Detector Calibration ⇒ Page 5-12

The purpose of this Service Calibration is to calibrate the Drop Detector (located in the Service Station) in relation to the Carriage Assembly.

5. Line Sensor Calibration ⇒ Page 5-14

The purpose of this Service Calibration is to calibrate the intensity of the Line Sensor. An incorrect calibration can result in edge-detection failures during media loading and incorrect reading of prints that are used for alignment or calibration.

6. Carriage Setup ⇒ Page 5-17

The purpose of this Service Calibration is to reset the ink short thresholds after replacing the Carriage PCA.

7. Color Sensor ⇒ Page 5-18

The purpose of this Service Calibration is to calibrate the Color Sensor.

If ALL the Calibrations need to be performed (for example, when both the Formatter and the Print Mech PCA have been replaced), you must perform them in the following order:

- **Drop Detector/Service Station Calibration.**
- **Line Sensor/Scan Axis Calibration.**
- **Paper Advance Calibration.**

Entering the Service Calibrations Menu

1. Once the message "Ready" or "Ready for paper" is displayed on the front-panel, press the **Menu** key.



2. For Call Agents who will request the user to perform certain Service Utilities, once inside the "Main Menu", press the **Down** arrow key and the **Cancel** key together. You are now in the **Service Tools** Menu.



3. Use the **Arrow** keys to scroll to the **Service calibrations** menu option and press the **OK** key.

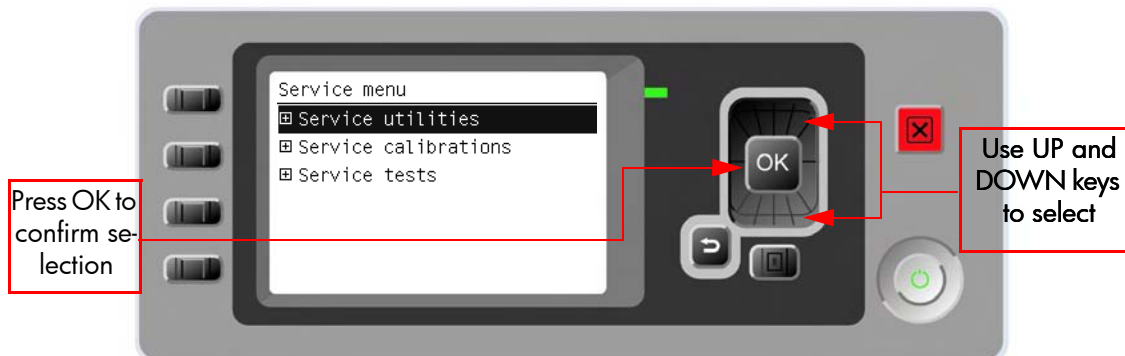

4. Use the **Arrow** keys to scroll through the Service calibrations selections and press the **OK** key to begin a specific operation when the required Service Utility is highlighted.

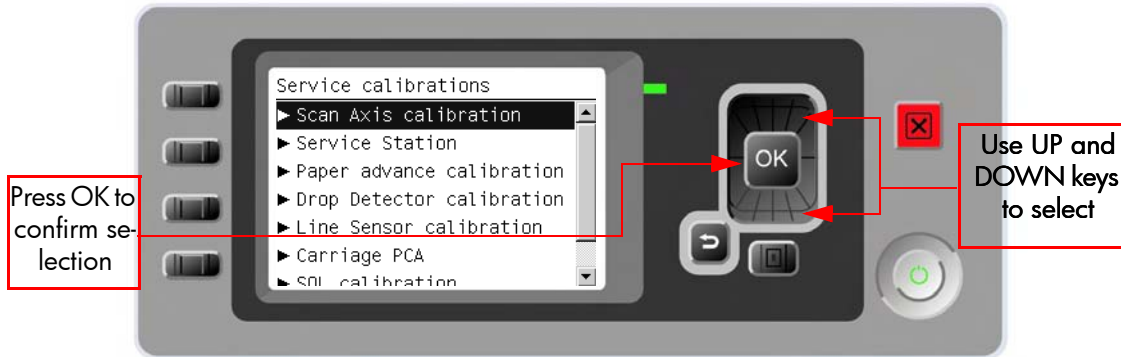

If the printer is not used for 135 seconds, the printer exits out of the Service Utilities Menu and you must repeat the above steps to enter Service Utilities again.

In some cases a quick press of a button may not be recognized by the Printer. When pressing a button, be sure to press it deliberately and all the way to the bottom of its travel.

Scan Axis Calibration

The purpose of this Service Calibration is to carry out a PWM check, calibrate the intensity of the Line Sensor and calibrate the Line Sensor position to the Black Printhead.

Perform the Scan Axis Calibration whenever:

- Carriage is disassembled or replaced.
- Encoder Strip is disassembled or replaced.
- Center Platen is disassembled or replaced.

Perform the Scan Axis Calibration as follows:

Make sure you load one of the following media into the Printer before performing this calibration:

- HP Bond Paper.
- HP Glossy Media.
- HP Coated Paper.
- HP Productivity Photo Gloss.
- HP Heavyweight Coated Paper.
- HP Super Heavyweight Coated Paper.
- HP Bright White Inkjet Paper.

1. In the Service Calibrations submenu, scroll to **Scan Axis Calibration** and press **Enter**.

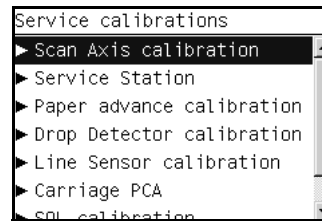

2. For the current version of the printer this Service Calibration is not yet implemented.

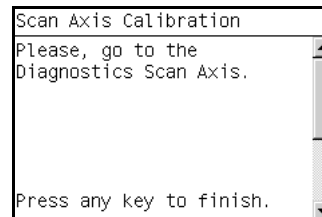

Service Station Calibration

The purpose of this Service Calibration is to calibrate the Service Station in relation to the Carriage Assembly.

Perform the Service Station Calibration whenever:

- Carriage Assembly is disassembled or replaced.
- Service Station is disassembled or replaced.
- Primer replaced.
- Drop Detector replaced.
- Aerosol Fan replaced.

1. In the Service Calibrations submenu, scroll to **Service Station** and press **Enter**.

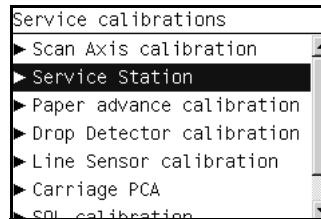

2. For the current version of the printer this Service Calibration is not yet implemented.

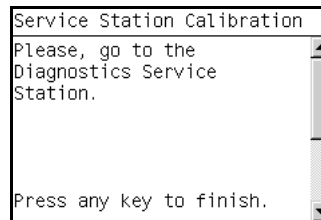

Paper Advance Calibration

The purpose of this Service Calibration is to calibrate the nominal advance of the media. This calibration is necessary to control the exact movement of the media in order to avoid print quality problems like banding.

In order to perform this Calibration, you should order the Paper Advance Calibration Kit (Part Number Q1273-60125) which contains two sheets of HP Productivity Gloss Media.

Perform the Service Accuracy Calibration whenever:

- Banding is detected in prints.
- Drive Roller is disassembled or replaced.
- Paper-axis Assembly is disassembled or replaced.

The Paper Advance Calibration is split into three parts and should **always** be done in this order:

1. Print Calibration Pattern - The Printer first calibrates the Analog Encoder and then prints the Paper Advance Calibration pattern.
2. Scan Calibration Pattern - The Printer scans the Paper Advance Calibration pattern in order to calibrate the nominal advance of the media.

Only scan the Calibration Pattern in the Printer that was used to actually print it. Using the Calibration in a different Printer could cause it to experience media advance problems. After scanning the Calibration Pattern, it should be discarded.

3. Clean Drive Roller - After loading media that the customer will use, the Printer “prepares” the media path to prevent any future advance problems.

Perform the Paper Advance Calibration as follows:

Make sure that you unload media from the Printer before performing the Paper Advance Calibration.

4. In the Service Calibrations submenu, scroll to “Paper Advance Calibration” and press **OK**.

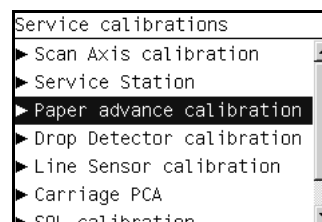

5. In the Paper Advance Calibration submenu, scroll to **Print Calibration Pattern** and press **OK**.

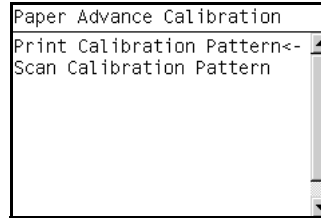

6. When the following message appears on the front panel, you must select whether you would like to continue with the calibration by pressing the **OK** key. Press **Back** or **Cancel** to exit the calibration.

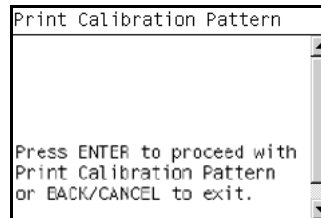

7. The Printer will start to calibrate the Analog Encoder and the following message will be displayed on the Front Panel.

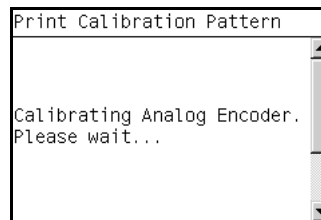

If the Calibration is not done or if the values are out of the limits, a warning message will appear on the Front Panel. In this case, try the following:

- Check that the Printer has the latest Firmware version. If not, update the Firmware to the latest version.
 - Retry the Paper Advance Calibration.
8. Once the Analog Encoder has been calibrated correctly, the following message will appear on the Front Panel. Press the **OK** key in order to start the media load process.

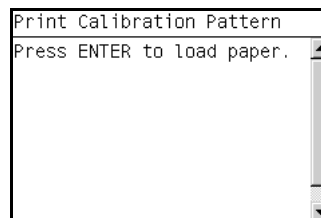

9. Load a sheet of HP Productivity Gloss Media that was included in the Paper Advance Calibration Kit (Part Number Q1273-60125) following the instructions on the Front Panel. If the kit is not available, then cut a

piece of HP Productivity Gloss Media that is 36 inches wide and at least 45 inches long.

10. Once the media is loaded into the Printer, the following message will appear on the Front Panel. If roll media has been used instead of cut sheet media, then you will need to unroll a minimum of 1 meter of media in order to prevent any back tension which could cause any media advance problems. Press the **OK** key to continue.

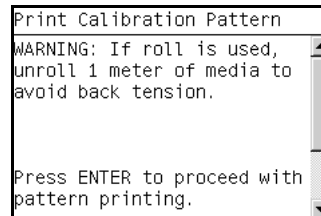

11. The Printer will start to print the Paper Advance Calibration Pattern. This could take several minutes during which the following message will be displayed on the Front Panel.

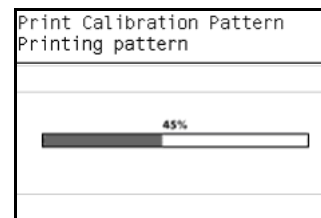

12. Once the Accuracy Calibration Pattern has been printed successfully, the Front panel will prompt you to continue.
13. Press the **Enter** key to continue.

If the Paper Advance Calibration fails for any reason, a warning message will appear on the Front Panel. In this case, try the following:

- Retry the Paper Advance Calibration.
- If necessary, perform a Printhead Recovery through the Front Panel and retry the Calibration.

Remove the pattern from the printer and leave it to dry for a few minutes before continuing with the Calibration.

MAKE SURE NO MEDIA IS LOADED INTO THE PRINTER BEFORE STARTING TO SCAN THE CALIBRATION PATTERN.

14. You will need to re-enter the Paper Advance Calibration submenu and scroll to Scan Calibration Pattern and press **OK**.

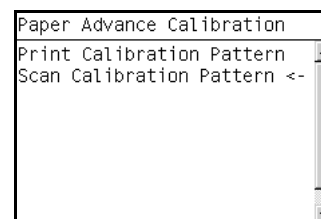

- 15.** When the following message appears on the front panel, you must select whether you would like to continue with the calibration by pressing the **OK** key. Press **Back** or **Cancel** to exit the calibration.

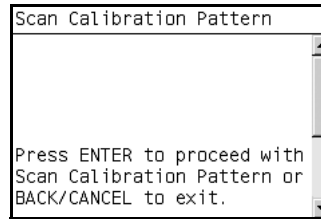

- 16.** A message will appear advising you that you will need to load the Calibration Pattern in to the Printer. Make sure that you rotate the printed pattern 90° clockwise and reload it printed-side down, so that the black arrows go into the printer first. Press the **OK** key to continue.

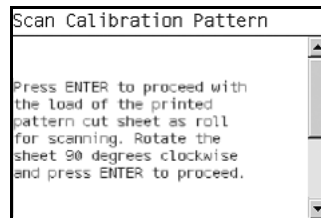

Take note that the Calibration Pattern will be loaded as a Roll and NOT as a Sheet.

Only scan the Calibration Pattern in the Printer that was used to actually print it. Using the Calibration in a different Printer could cause it to experience media advance problems.

After scanning the Calibration Pattern, it should be discarded. When Loading the Calibration Pattern, use the Cutter blade on the Print Platen to align the edge of the sheet. If you follow this advise, you will prevent the cutter from cutting a section of the Calibration Pattern, which could cause the Calibration to FAIL.

- 17.** Load the Calibration Pattern following the instructions on the Front Panel. Once the Calibration Pattern is loaded correctly, the following message will be displayed on the Front Panel. Press the **OK** key to continue.

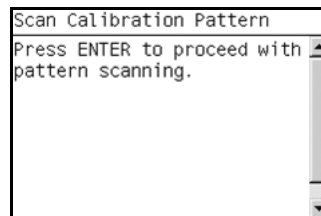

- 18.** The Printer will scan the Calibration Pattern which could take several minutes. Once the calibration is completed successfully, the following

message will be displayed on the Front Panel. Press the **OK** key to continue.

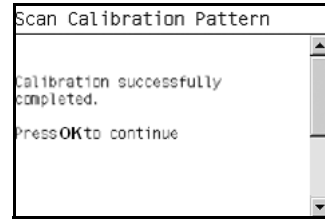

If the Paper Advance Calibration fails for any reason, a warning message will appear on the Front Panel. In this case, try the following:

- Check that the Calibration Pattern was not incorrectly cut (trimming the actual pattern) during the media load process. If this is the case, perform the Paper Advance Calibration again from **step 1**.
- Perform a Line Sensor Calibration (⇒ Page 5-14) and then rescan the Calibration pattern.
- Replace the Line Sensor ⇒ Page 8-109.
- If the problem continues, replace the Media Advance Driver ⇒ Page 8-155.

Drop Detector Calibration

The purpose of this Service Calibration is to calibrate the Drop Detector (located in the Service Station) in relation to the Carriage Assembly.

Perform the Drop Detector Calibration whenever:

- Drop Detector is disassembled or replaced.
- Carriage Assembly is disassembled or replaced.
- Service Station is disassembled or replaced.

Perform the Drop Detector Calibration as follows:

1. In the Service Calibrations submenu, scroll to **Drop Detector Calibration** and press **OK**.

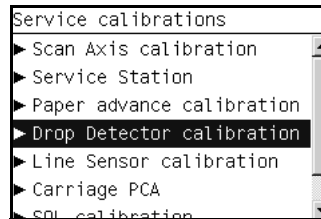

2. When the following message appears on the front panel, you must select whether you would like to continue with the calibration by pressing the **OK** key. Press **Back** or **Cancel** to exit the calibration.

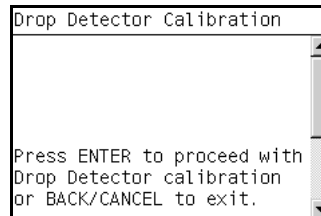

3. The Printer will start to calibrate the Drop Detector.

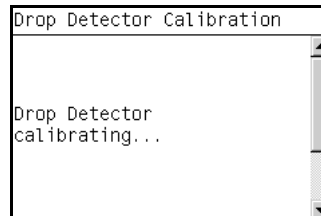

4. Once the Drop Detector has been calibrated, the results will be displayed on the Front Panel. Press **OK** to finish the calibration.

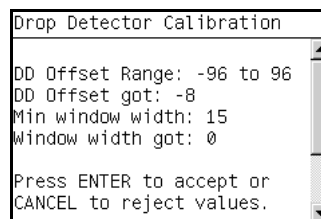

5. Once the calibration is completed, OK will be displayed on the Front Panel.

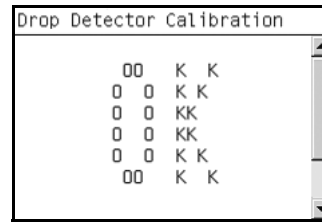

Line Sensor Calibration

The purpose of this Service Calibration is to calibrate the intensity of the line sensor in the Carriage PCA. An incorrect calibration can result in edge-detection failures during media loading and incorrect reading of prints that are used for alignment or calibration.

Perform the Line Sensor Calibration whenever:

- Edge detect procedure fails during media loading.
- Carriage is disassembled or replaced.
- Line Sensor is disassembled or replaced.
- Banding is detected in prints.
- Misalignment between colors is detected.

Perform the Line Sensor Calibration as follows:

Make sure you load one of the following media into the Printer before performing this calibration:

- HP Bond Paper.
- HP Glossy Media.
- HP Coated Paper.
- HP Productivity Photo Gloss.
- HP Heavyweight Coated Paper.
- HP Super Heavyweight Coated Paper.
- HP Bright White Inkjet Paper.

1. In the Service Calibrations submenu, scroll to Line Sensor Calibration and press **OK**.

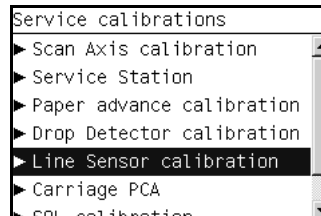

2. When the following message appears on the front panel, you must select whether you would like to continue with the calibration by pressing the **OK** key. Press **Back** or **Cancel** to exit the calibration.

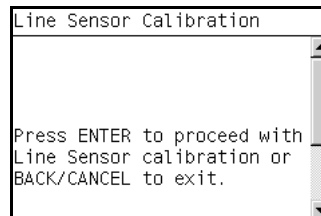

3. If media is not loaded, the following message appears on the front panel. Load media in to the Printer and start again from **step 1**.

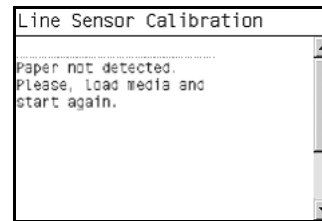

Before continuing, the Printer will check the following:

- The Media Lever is in the lowered position.
- The correct paper type is loaded (check list on previous page).
- The correct paper size (minimum paper size 24 inches).

If these conditions are **not** met, a warning will be displayed on the Front Panel and you will need to restart the Calibration from **step 1**.

Make sure you keep your hands away from the Print Platen as the Carriage will be moving at high speed and you could injure yourself or damage the Carriage Assembly.

4. The Printer will start to calibrate the Line Sensor. Once the Line Sensor has been calibrated, the results will be displayed on the Front Panel. Press **OK** to continue or press **Back** or **Cancel** to exit the calibration.

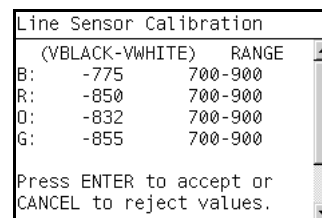

If the values are not within the range specified, an error will appear on the Front Panel. In this case, try the following:

- Try the Scan-Axis Calibration again.
- Replace the Line Sensor

5. The Printer will start to calibrate the Line Sensor position to the Black Printhead. It will print a line of black dots and then scan them:



6. Once the Line Sensor has been calibrated, the results will be displayed on the Front Panel. Press **OK** to finish the calibration or press **Back** or **Cancel** to exit the calibration.

```

Line Sensor Calibration
Y Offset Range: 30 to 59
Y Offset got: 43
X Offset Range: -24 to 24
X Offset got: 14
X SVS Offset: -1050 to 1050
X SVS Offset got: -944
Press any key to exit.

```

7. The Printer will now perform the Printhead Alignment. When the following message appears on the front panel, you must select whether you would like to continue with the calibration by pressing the **OK** key. Press **Back** or **Cancel** to exit the calibration.

```

Line Sensor Calibration
Press ENTER to proceed with
Pen Alignment calibration
or BACK/CANCEL to exit.

```

8. Once the Printhead Alignment is completed, the following message will be displayed on the Front Panel. Press the **OK** key to continue.

```

Printhead alignment
Calibration successfully
completed.
Press OK to continue

```

If the Printhead Alignment fails for any reason, a warning message will appear on the Front Panel. In this case, try the following:

- Enter the Front Panel menu and retry the Printhead Alignment. If the Alignment completes successfully, then perform the Color Calibration.
 - If the Alignment fails again, check the Alignment pattern to see if any of the Printheads are printing incorrectly. If necessary, perform a Printhead Recovery through the Front Panel and retry the Printhead Alignment.
9. Once the complete Line Sensor calibration is completed successfully, OK will be displayed on the Front Panel.

```

Line Sensor Calibration
      OO  K  K
     O O  K K
    O O  KK
   O O  KK
  O O  K K
 OO   K  K

```

Carriage PCA

The purpose of this Service Calibration is to reset the ink short thresholds after replacing the Carriage PCA.

Perform the Carriage Setup as follows:

1. In the Service Calibrations submenu, scroll to Carriage PCA and press **OK**.

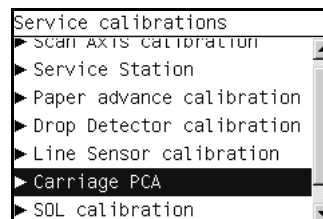

2. For the current version of the printer this Service Calibration is not yet implemented.

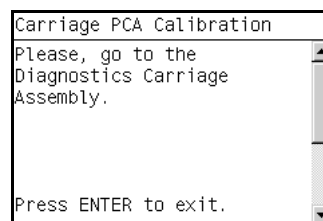

Color Sensor (ESP) Calibration

The purpose of this Service Calibration is to calibrate the Color Sensor (Color Sensor (ESP)).

Perform the Color Sensor (ESP) Calibration as follows:

1. In the Service Calibrations submenu, scroll to **Color Sensor (ESP) Calibration** and press **OK**.

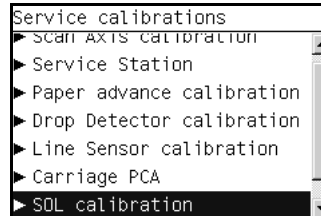

2. When the following message appears on the front panel, you must select whether you would like to continue with the Carriage Setup by pressing **OK**. Press **Back** or **Cancel** to exit the utility.

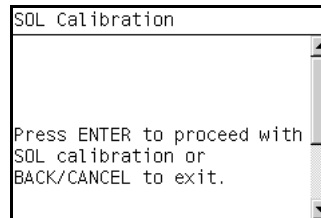

3. The printer will start to calibrate the Color Sensor:

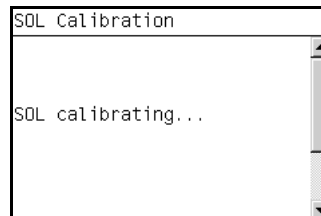

4. Once the Color Sensor calibration has completed successfully, OK will be displayed on the Front Panel.

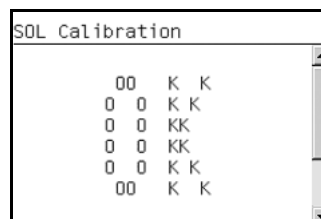

Print Quality

6

- Print Quality 6-2
 - Print Quality Troubleshooting Actions 6-2
- How to Use the Service Image Quality Diagnostic Print 6-3
 - What is the Service Image Quality Diagnostic Print? 6-3
 - Considerations for Printing the Diagnostic Print 6-4
 - Printing the Service Image Quality Diagnostic Print 6-4
 - Diagnostic Part 1: Printhead Problems 6-6
 - Diagnostic Part 2: Alignment Test 6-7
 - Diagnostic Part 3: Printheads & Paper Advance Test 6-8
 - No Printing Defects Found in the Diagnostic Print 6-9
 - Printing the Advance Diagnostics Print 6-10
 - Advanced Diagnostic: Paper Advance Print 6-11
 - Advanced Diagnostic: Visual Alignment Diagnostic Print 6-14
 - Advance Diagnostic: Visual Nozzle Health. 6-16
 - Advance Diagnostic: Force Drop Detection 6-17
- Print Quality General Advice 6-18
- Troubleshooting Print Quality Problems 6-18
 - Horizontal Lines Across the Image (Banding) 6-18
 - Lines are Missing or Thinner than Expected 6-19
 - Problems with Stepped Lines 6-19
 - Lines are Printed Double or in Wrong Colors 6-20
 - Lines are discontinuous 6-21
 - Lines are Blurred (Ink Bleeds from Lines) 6-21
 - Problems with Graininess 6-22
 - Paper is not Flat 6-23
 - Print Scuffing or Scratching when Touched 6-24
 - Ink marks on the paper 6-24
 - Problems with the Edges of objects 6-25
 - Bronzing 6-26
 - Black and white prints do not look neutral 6-26
 - Horizontal lines at the end of a cut sheet print 6-26
 - Vertical lines of different colors 6-26
 - White spots on the print 6-26
 - Problems with Color Accuracy 6-27
 - Output Only Contains a Partial Print 6-27
 - Problems with Image Clipping 6-28
 - Some objects are missing from the printed image 6-28
 - A PDF file is clipped or objects are missing 6-29

Print Quality

PHONE SUPPORT

Print Quality Troubleshooting Actions

For some Print Quality problems, a Call Agent can try and troubleshoot the Printer by requesting the Customer to perform certain actions. Using this process, most problems can resolved without the need of an on-site visit.

When faced with a Print Quality problem, perform the following actions in order to resolve the problem:

- 1** Printer Configuration:
 - Check that the **paper type** selected in the Front Panel is the same as the paper type loaded into the Printer.
 - Make sure that the correct Print Quality settings are used for different types of print content. Refer to Page 6-2 for further information.
 - Dry time should be set to "Optimal".
- 2** Perform Printhead recovery (Main Menu/Image Quality Maintenance/Clean Printheads).
- 3** Media:
 - Select the correct media type through the front panel when loading it.
 - Make sure that HP or HP-approved media is being used.
- 4** Perform the Printhead Alignment (Main Menu/Image Quality Maintenance/Align Printheads).
- 5** Check if the latest version of the firmware is installed. If not, install the latest firmware revision.

How to Use the Service Image Quality Diagnostic Print

What is the Service Image Quality Diagnostic Print?

The Printer contains an internal Image Quality Test which helps you to diagnose the possible source of any image quality defects. The Service IQ Diagnostic Print is available in the following options:

- 1 *Image Quality Service Best Plot.* This plot helps you to diagnose in more detail the possible source of any image quality defects. It is accessible through the Service Utility Menu.

The *Image Quality Service Best Plot* uses the Best Print Mode and is divided in to three parts as follows:

- Printhead Reliability Test. The purpose of this test is to identify which Printhead is faulty.
- Printhead Alignment Test. This test is designed to check any color-to-color and bi-directional misalignment the printer may have.
- Printheads and Media Advance test. This test is designed to check whether the Printheads and the Media Advance Mechanism are working correctly.

- 2 *Image Quality Service Normal Plot.* This plot is the same as the *Image Quality Service Best Plot* but uses the Normal Print Mode.

- 3 *Advanced Diagnostic Plot.* These tests provide more information of the IQ defects that we could find in the *Image Quality Service* plot.

The *Advanced Diagnostic Plot* is divided into the following parts:

- Visual Media Advanced Diagnostic. Used to check advance reliability.
- Visual Alignment Diagnostic. Used to check pen alignment reliability.
- Visual Nozzle health Diagnostic. Used to check nozzle health reliability.
- Force Drop Detection. Used to reset the nozzle health historic data base and force new drop detection.

Considerations for Printing the Diagnostic Print

- 1 The IQ Diagnostic Print prints in A3 and B sizes so you must have media loaded (roll or sheet) that is this size or larger.
- 2 Use the same type of media that the customer was using when they found the image quality problem.
- 3 If the customer is using non-HP media and after the Image Quality Test you still have the same image quality problems, change to genuine HP media and repeat the Image Quality Test.
- 4 If you do not see any problems with the Image Quality Test, then the problem may not be with the printer itself. The problem may be with the RIP or the driver for example.

However, if you do see problems with the Image Quality Test then continue with the Advanced Diagnostic procedures which will help you to diagnose the problem.

Printing the Service Image Quality Diagnostic Print

- 1 In the Service Utilities submenu, scroll to "Diagnostic Print" and press **OK**.



- 2 You will be given three options. Use the **Arrow** keys to make the selection and press the **OK** key to start printing the required Diagnostic Print or to enter the Advanced Diagnostics menu.

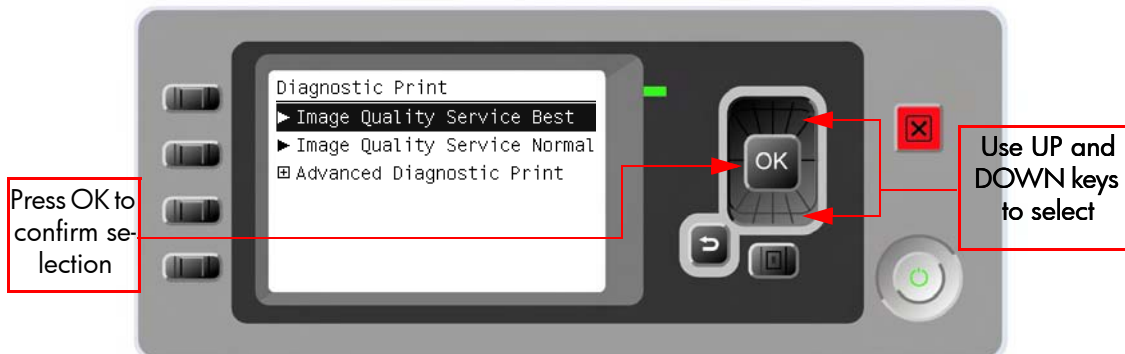

- 3 If you selected the Advanced Diagnostics Prints in the previous step, use the **Arrow** keys to make the required selection Paper Advance, Visual

Alignment Diagnostic, Nozzle Health, Force Drop Detection or Print Banding Plot, and press the **Enter** key to start printing.

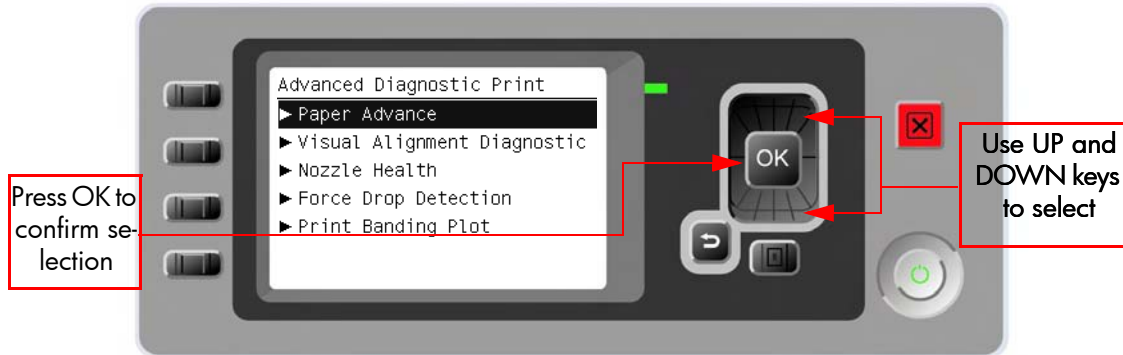

- 4** Make sure media is loaded, the Media Lever is lowered and that the Ink System is correctly installed. Press the **OK** key to print the Diagnostic Print or press **Back/Cancel** to exit without printing the Diagnostic Print.

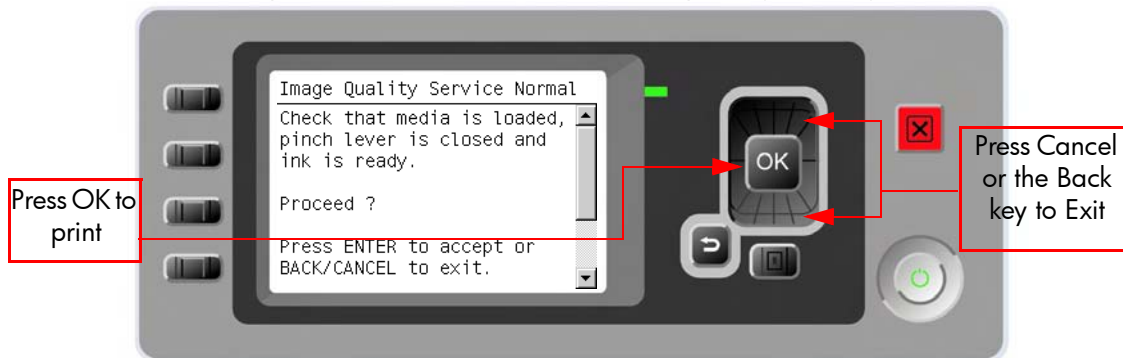

- 5** The selected Diagnostic Print will now be printed.

Diagnostic Part 1: Printhead Problems

The Nozzle print Test test is designed to check if the Printhead nozzles print correctly.

The nozzles check (bottom of the plot) is printed in a one-pass full swath mode. The diagnostics test prints out every single nozzle of each Printhead without applying an error hiding or alignment algorithm.

For each Printhead, you can see both the adjacent and the consecutive nozzles.

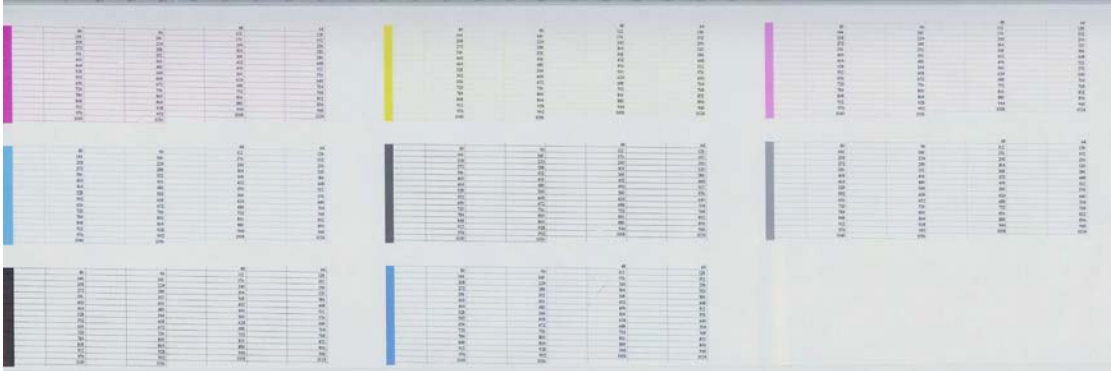

If any nozzles not printing correctly they will be shown on the right of each Printhead Nozzle test. There is a series of numbered stepped diagonal lines. If one or more of the nozzles are malfunctioning or mis-positioned, you will see that the stepped lines are broken or misdirected in one or more places.

Corrective Action

If the printer has nozzle defects, it does not mean that you will not get perfect print quality results because the Printer can automatically compensate for this so there is no need to replace the Printhead.

The method of improving Nozzle Defects is to:

- 1 Recover the Printheads, using the Front Panel Main Menu/Image Quality Maintenance/Clean Printheads option.
- 2 Reprint the Printhead Nozzles Test Plot to verify that the defective nozzles have been corrected.
- 3 If the problem continues, replace the defective Printhead.

Diagnostic Part 2: Alignment Test

This test is designed to check any color-to-color and bi-directional misalignment the printer may have.



- 1 If the Printer is experiencing **horizontal** misalignment problems, the Alignment Test will show something like this:

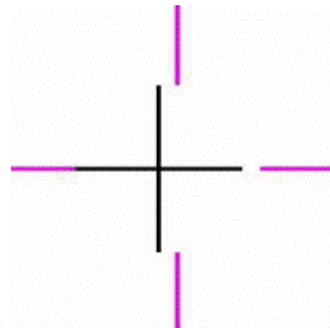

- 2 If the Printer is experiencing **vertical** misalignment problems, the Alignment Test will show something like this:

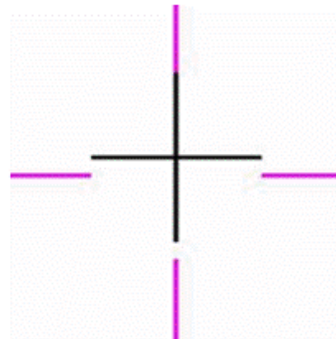

- 3 If the Printer is experiencing **bi-directional** misalignment problems, the Alignment Test will show something like this:



Corrective Action

Perform a Printhead Alignment, using the same paper type with which you were experiencing unacceptable image quality, if feasible (some paper types are not suitable for Printhead Alignment).

Diagnostic Part 3: Printheads & Paper Advance Test

This test is designed to check whether the Printheads and the Paper Advance Mechanism are working correctly. This part of the Image Quality Test should **not** be used to check for color consistency or accuracy.

Banding

If the Printer is experiencing a banding problem, you will see repetitive horizontal bands within the printed image.

- Dark line banding repeated along the band (from top to bottom at the same distance).
- White line banding repeated along the band (from top to bottom at the same distance).

The plot is printed in Best or Normal mode (according to the menu option selected) with Error Hiding ON. The first top band has 100% ink density patches while the bottom band has 50% ink density.



Troubleshooting Banding Problems

If banding **does not** occur in ALL the colors, then it is more than likely a Printhead problem. In this case, try the following:

- 1 Check that the appropriate print quality settings are being used.
- 2 Recover the printheads using the option through the Front Panel (Main Menu/Image Quality Maintenance/Clean Printheads). Reprint the Diagnostic Print or the print file and if the problem persists, replace the faulty Printhead.

If banding **does** occur in ALL the colors, then it is more than likely a Paper Advance problem:

- If the bands are light, it means that the paper has advanced too much.
- If the bands are dark, it means that the paper hasn't advanced enough.
- In high quality modes, graininess in ALL colors can indicate problems either with alignment or Paper Advance.

In order to solve any of these problems, try the following:

- 1 Check that the appropriate print quality settings are being used.
- 2 Check that the loaded media is the same type as selected in the printer. Verify this using the option through the Front Panel (Main Menu/Paper menu/View loaded paper).
- 3 If the customer is using low quality paper, try recommending better quality paper (preferable HP paper). Printer performance can only be guaranteed by using recommended papers.
- 4 Perform the Paper Advance Calibration using the same type of paper that will be used for the final print.

If there is white point banding in only one color band and the problem cannot be fixed using the Printhead recoveries, in some cases using the force a drop detection option can fix this issue (see Advance Diagnostics: Force Drop Detection).

No Printing Defects Found in the Diagnostic Print

If all the test patterns from the Diagnostic Print are correct and you still experience Image Quality problems, you can use the following procedures to resolve the problem.

- Print Visual Media Advance Diagnostic
- Print Visual Alignment Diagnostic
- Print Visual Nozzle Health Diagnostic
- Force Drop Detection

Printing the Advance Diagnostics Print

- 1 In the Service Utilities submenu, scroll to “Diagnostic Print” and press **OK**.



- 2 You will be given three options. Use the **Arrow** keys to select the Advanced Diagnostics menu.

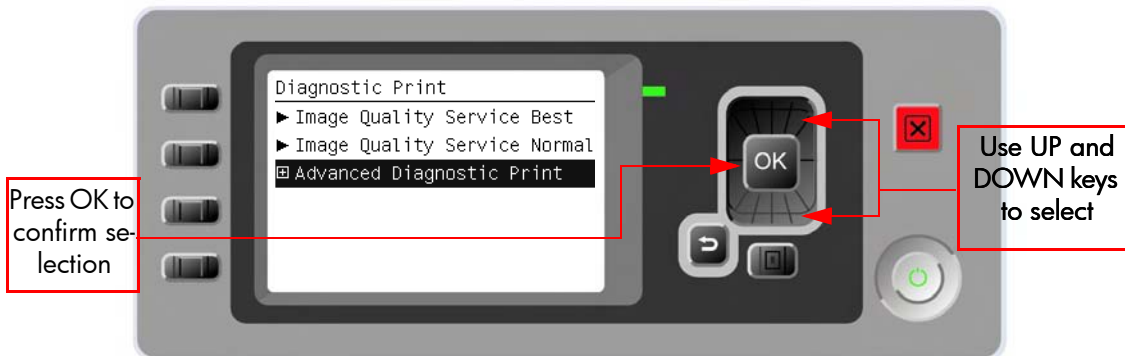

- 3 From the displayed options, use the **Arrow** keys to make the required selection Paper Advance, Visual Alignment Diagnostic, Nozzle Health, Force Drop Detection or Print Banding Plot, and press the **Enter** key to start printing.

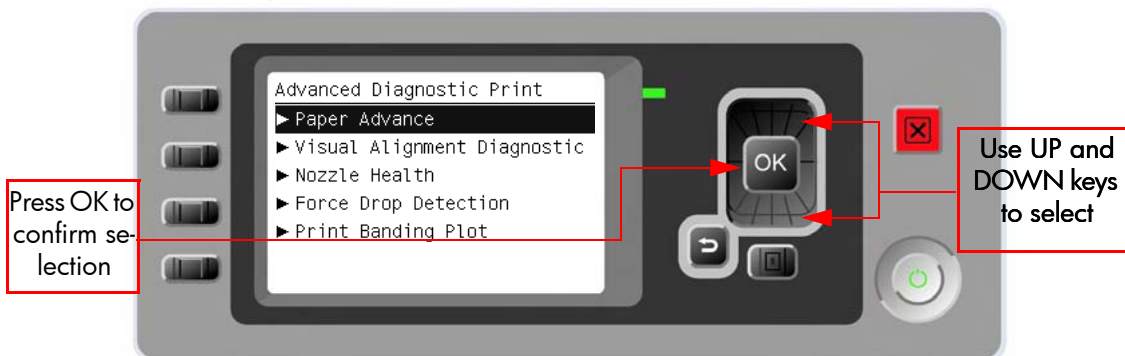

- 4 Make sure media is loaded, the Media Lever is lowered and that the Ink System is correctly installed. Press the **OK** key to print the Diagnostic Print or press **Back/Cancel** to exit without printing the Diagnostic Print.

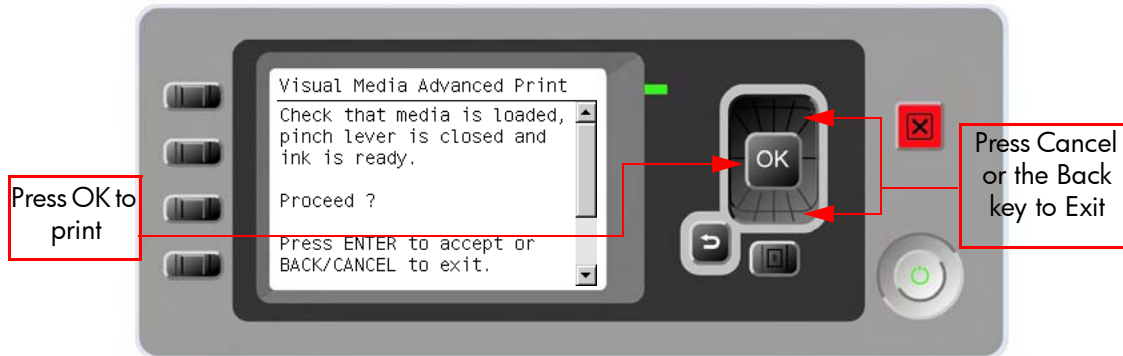

- 5 The selected Advanced Diagnostic Print will now be printed.

Advanced Diagnostic: Paper Advance Print

This plot helps you to visually check any alignment problems of the printer. You use it to precisely measure the media advance error with a one dot row accuracy, and to verify the stability of the media advance.

The whitest vertical line should be positioned in the 0 offset column with minor variations between +2 and -2 columns. If the offset is not positioned on the 0 column or between +2 and -2 columns and the whitest vertical varies a lot the printer requires media advance recalibration.

It is very important to verify that the loaded media is the same media type as selected in the front panel. Verify this using the option through the Front Panel (Main Menu/Paper menu/View loaded paper). The wrong type of paper selected will produce an offset error in the Visual Media Advance print.

The following plot shows correct media advance, there is a straight white line positioned close to the 0 column for the majority of the points.

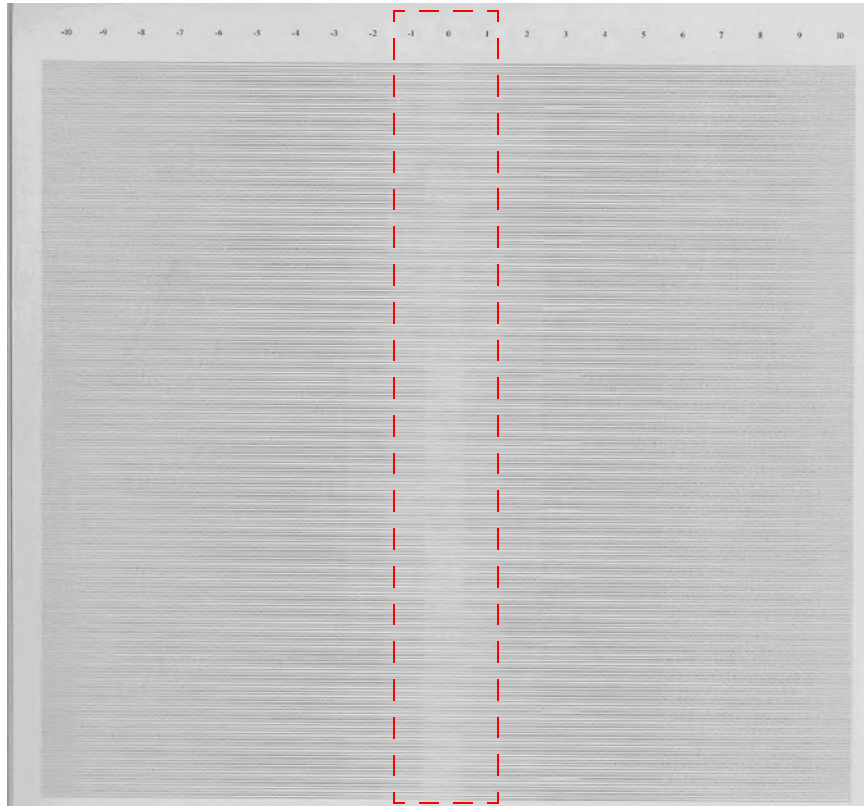

The following plot shows a bad media advance, there is a straight white line positioned close to the -6 column, instead of the 0 column for the majority of the points.



Advanced Diagnostic: Visual Alignment Diagnostic Print

This plot helps you to visually check any alignment problems of the printer. You use it to precisely measure the alignment error with a one dot row accuracy.

To ensure you obtain meaningful results, use the same type of media that the customer was using when they encountered the image quality problem

For the printer to be considered correctly aligned, the results must be within ± 1 dot row.

The illustration shows the complete Visual Alignment Diagnostic print that identifies each of the specific alignment test results covered.

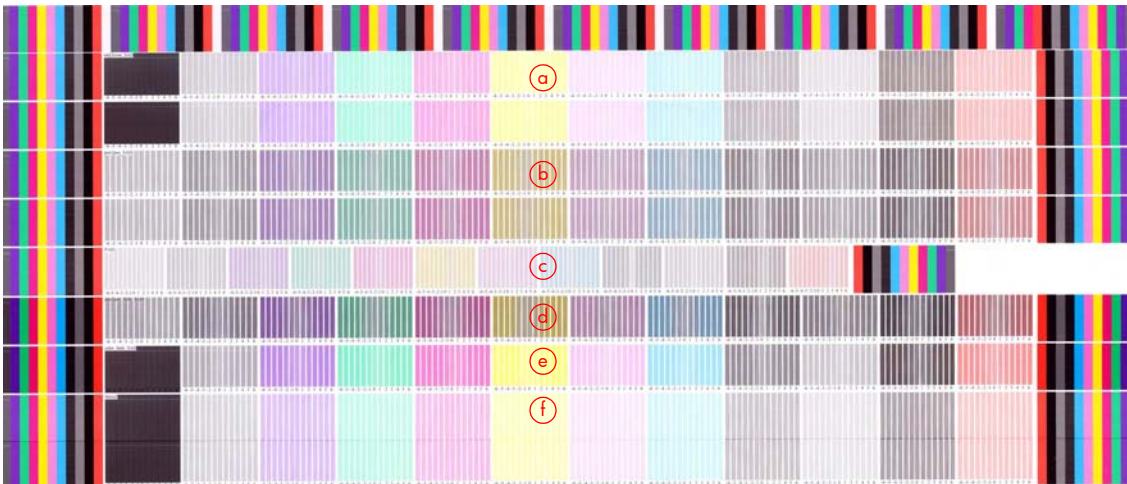

The Visual Alignment Diagnostic print shows the following diagnostic test results:

- a** odd2even_SAD: Horizontal direction in forward and reverse.
- b** pen2pen_SAD: Horizontal direction.
- c** PAD
- d** pen2pen_bidir_SAD: Horizontal bi-direction.
- e** color_bidir_SAD: Horizontal bi-direction.
- f** thetaZ and VLS: only contour part (dark bands).

The following plot shows correct visual alignment, the lightest band is positioned on the 0 column.

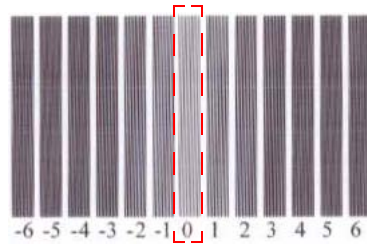

For the thetaZ and VLS diagnostics the dark band of the print is the area to check. In the following example print the lightest segment of the dark band is positioned on the -1 column.

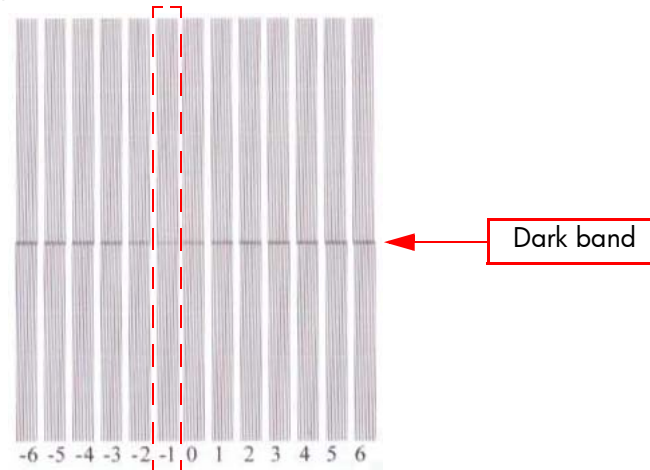

If the customer is using non-HP media and after the Image Quality Test you still have the same image quality problems, change to genuine HP media and repeat the Image Quality Test. The best alignment calibration is obtained using HP Photo Paper.

Advance Diagnostic: Visual Nozzle Health.

The print contains three separate parts.

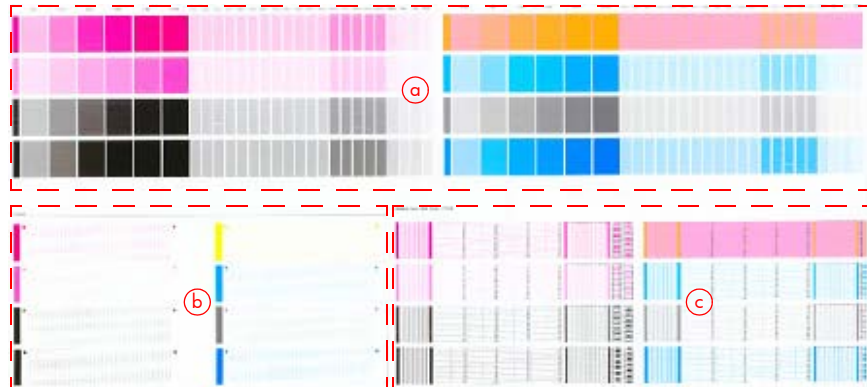

- a** The Variable Frequency Nozzle health plot with odd/even nozzles separation. This is used to detect misdirected or weak nozzles, nozzles not working correctly at all frequencies, or even Gloss Enhancer (GE) color problems.
- b** Inspector measuring tool test plot.
- c** **Nozzle Print Test** which is also part of the Image Quality Service Plot. This test is designed to check that the Printhead nozzles print correctly. The test prints out every single nozzle of each Printhead. No error hiding or Printhead Alignment algorithm is applied. For each Printhead, you can see both the adjacent and the consecutive nozzles.

This is what you would see in the **Nozzle Print Test** part if there are nozzles not printing correctly:

- 1** On the right of each Printhead Nozzle test, there is a series of numbered stepped diagonal lines. If one or more of the nozzles are malfunctioning or mis-positioned, you will see that the stepped lines are broken or misdirected in one or more places.
- 2** On the left of each Printhead Nozzle test, there is a series of horizontal straight lines. If one or more nozzles are misdirected there will be unequal spaces between the corresponding lines.

How to fix the Nozzle Defects

If the printer has nozzle defects, it does not mean that you will not get perfect print quality results. The printer has automatic procedures to hide many nozzle defects.

- 1** Recover the Printheads using the option through the Front Panel (Main menu/Image quality maintenance/clean Printheads).
- 2** Reprint the Nozzle Print test to check that the defective nozzles have been corrected.
- 3** If the problem continues, replace the faulty Printhead.

Advance Diagnostic: Force Drop Detection

If **Nozzle Print Test** plot has persistent white point banding in only one color that cannot be fixed with a recovery you can use this option to resolve the problem by resetting the nozzle health data base so that all nozzles are assumed to be correct.

Once the nozzle health data base has been reset drop detection is forced.

The normal cause of this white point banding in a single color is the incorrect detection of failed nozzles by the drop detector.

Troubleshooting Print Quality Problems

Print Quality General Advice

- 1 To achieve the best performance from the printer, only genuine HP accessories and supplies should be used.
- 2 Make sure that the **paper type** selected in the Front Panel is the same as the paper type loaded into the Printer.
- 3 The most appropriate print quality settings for your purposes. A lower print quality is likely to be seen if the print quality slider has been moved to the **Speed** end of the scale, or the custom quality level set to **Fast**.
- 4 Check that the environmental conditions (temperature, humidity) are within the temperature/humidity range as specified for the Printer (refer to the User's Guide for further information).
- 5 Check that the ink cartridges and printheads have not exceeded their expiration dates.

Horizontal Lines Across the Image (Banding)

Description of problem

When you look at the image you have printed, there are horizontal lines across the image. Shown below is an example of what you might see if you have this problem:



Corrective Action

- 1 Check that the paper type loaded corresponds to the paper type selected in the front panel and in the software.
- 2 Check that the appropriate print quality settings are being used and reprint the image. In some cases print quality problems can be resolved by selecting a higher print quality level.

- 3 Print the Service Image Diagnostics Print, and clean any printheads that need cleaning. Reprint the job in case the problem has been solved.
- 4 Check the paper advance calibration status. If the status is PENDING, y perform the paper advance calibration. After calibration reprint the job.

Lines are Missing or Thinner than Expected

Description of problem

Shown below is an example of what you might see if you have this problem:

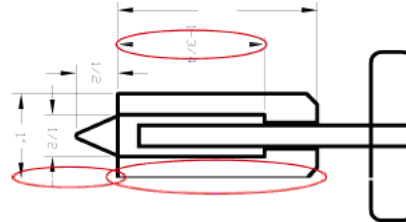

Corrective Action

- 1 Check that the paper type loaded corresponds to the paper type selected in the front panel and in the software.
- 2 Check that the appropriate print quality settings are being used. Select the custom print quality options in the Print dialog, and try turning on the Maximum detail option. Reprint the job in case the problem has been solved.
- 3 If the resolution of the image is greater than the printing resolution, a loss of line quality may be seen. You can find the Max. Application Resolution option in the Windows driver dialog's Advanced tab, under Document Options > Printer Features. Reprint the job in case the problem has been solved.
- 4 Check the Printhead alignment status. If the status is PENDING, perform the paper advance calibration. After alignment reprint the job.
- 5 Check the paper advance calibration status. If the status is PENDING, perform the paper advance calibration. After calibration reprint the job.
- 6 Using Part 3 of the Image Quality Diagnostic Print, check if there are a significant amount of nozzles out in the color that is **actually causing** the problem (if see you a problem with the Black color in the customer print, then only check the Black printhead in the Image Quality Diagnostic Print). If there is a significant amount of nozzles out then replace the faulty Printhead.

Problems with Stepped Lines

Description of problem

When you look at the image you have printed there are '**stepped lines**' in the borders of arrows and diagonal lines. The lines should be straight with no stepping.

Shown below is an example of what you might see if you have problems with Stepped Lines:



Corrective Action

- 1 The problems may be inherent in the image that you are trying to print. Try to improve the image with the **application** that generated the file.
- 2 Check that the appropriate print quality settings are being used.
- 3 Turn On the **Maximum Detail** option in the Driver.
- 4 Change the image rendering resolution to 300 dpi or 600 dpi depending on the printing needs. You can find the **Max. Application Resolution** option in the Windows driver dialog's Advanced tab, under Document Options > Printer Features.

Lines are Printed Double or in Wrong Colors

Description of problem

This problem can have various visible symptoms, as shown below:

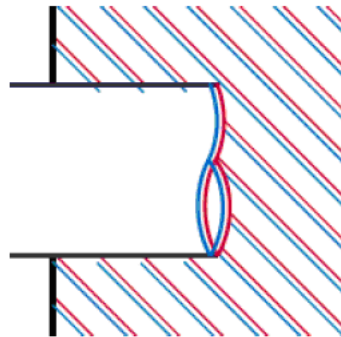

Colored lines are printed double, in different colors



Borders of colored blocks are wrongly colored

Corrective Action

- 1 Reseat the Printheads by removing them and then reinserting them.
- 2 Align the Printheads.

Lines are discontinuous

If the lines are broken in the following way:



- 1 Check that the appropriate print quality settings are being used.
- 2 Reseat the Printheads by removing them and then reinserting them.
- 3 Align the Printheads.

Lines are Blurred (Ink Bleeds from Lines)

Description of problem

This problem is often caused by the ink soaking into the paper, making the lines blurred and fuzzy. This could be because of the humidity in the air.



Corrective Action

- 1 Check that the environmental conditions (temperature, humidity) are suitable for high-quality printing.
- 2 Make sure that the **paper type** selected in the Front Panel is the same as the paper type loaded into the Printer.
- 3 Try using a heavier paper type, such as HP Heavyweight Coated Paper, HP Super Heavyweight Coated Paper, or Digital Fine Art paper.
- 4 If glossy paper is being used, try changing to a different type of glossy paper.
- 5 Select the custom print quality options in the Print dialog, and turn on the **More passes** option
- 6 Allow the prints time to dry separately; do NOT cover or stack them.
- 7 Align the printheads.

Problems with Graininess

Description of problem

Shown below is an example of what you might see if you have problems with graininess:



Corrective Action

- 1** Check that the paper type loaded corresponds to the paper type selected in the front panel and in the software.
- 2** Check that printing is on the correct side of the paper.
- 3** Check that the appropriate print quality settings are being used. Select the custom print quality options in the Print dialog, and try turning on the **More passes** detail option. Reprint the job in case the problem has been solved.
- 4** Check the Printhead alignment status. If the status is PENDING, perform the paper advance calibration. After alignment reprint the job.
- 5** Check the paper advance calibration status. If the status is PENDING, perform the paper advance calibration. After calibration reprint the job.

Paper is not Flat

Description of problem

If the paper does not lie flat when it comes out of the Printer, but has shallow waves in it, you are likely to see visible defects in the printed image, such as vertical stripes. This can happen when you use thin paper that becomes saturated with ink.

Shown below is an example of what you might see if you have problems with the paper not being flat:



Corrective Action

- 1** Check that the paper type loaded corresponds to the paper type selected in the front panel and in the software.
- 2** Try using a heavier paper type. When printing dense colors, it is recommended to use HP Heavyweight Coated Paper HP Super, Heavyweight Coated Paper or thicker Digital Fine Art papers.
- 3** Make sure that only genuine HP paper is being used.
- 4** Check that the appropriate print quality settings are being used.
- 5** Check that the environmental conditions (temperature, humidity) are within the temperature/humidity range as specified for the Printer (refer to the User's Guide for further information).

Print Scuffing or Scratching when Touched

Description of problem

The black ink pigment can smudge when touched by a finger, a pen, or some other object. This is particularly noticeable on coated paper, matte proofing paper, and fine art material.

Glossy paper may be extremely sensitive to damage from the basket or to anything else that it contacts soon after printing, depending on the amount of ink used and the environmental conditions at the time of printing.

Corrective Action

- 1 Handle prints carefully.
- 2 Avoid stacking prints on top of each other.
- 3 Disable the automatic cutter before printing, so that the print will not fall into the basket.

Ink marks on the paper

This problem may occur for several different reasons.

Horizontal smears on the front of coated paper

If a lot of ink is used on plain or coated paper, the paper absorbs the ink quickly and expands. As the printheads move over the paper, the printheads may come into contact with the paper and smear the printed image. This problem is normally seen only on cut sheets of paper (not on roll paper).

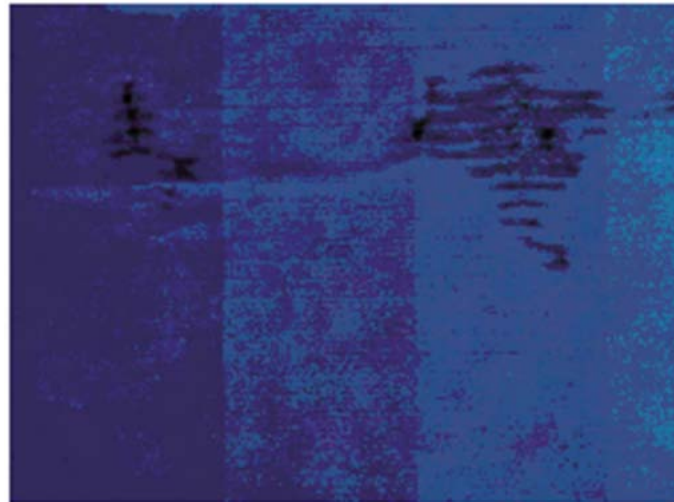

Corrective Action

- 1 Check that the paper type loaded corresponds to the paper type selected in the front panel and in the software.
- 2 Use a recommended paper type and the correct print settings.
- 3 If using sheet paper, try rotating the sheet 90 degrees. The orientation of the paper fibers may affect performance.

- 4 Try changing to a thicker paper type, such as HP Heavyweight Coated Paper, HP Super Heavyweight Coated Paper, or thicker Digital Fine Art papers.
- 5 Try to increase the margins by relocating the image to the center of the page with the software application being used.

Ink marks on the back of the paper

This can happen after a lot of border less printing, especially with non-standard paper sizes. Ink residues on the platen are likely to mark the back of the paper.

Corrective Action

- Clean the platen with a soft cloth. Clean each rib separately without touching the foam between the ribs.

Problems with the Edges of objects

Stepped or not sharp

The edges of objects or lines appear to be poorly defined or lighter in density than expected.



Corrective Action

- If the print quality slider has already been set to **Quality** in the Print dialog, select the custom print quality options, and try setting the quality level to **Normal**.

Darker than expected

The edges of objects seem darker than expected.



Corrective Action

- If the print quality slider has already been set to **Quality** in the Print dialog, select the custom print quality options, and try setting the quality level to **Normal**.

Bronzing

When printing on photo paper with gray and black ink only a gloss differential problem can be encountered when light is directly reflected from the print, producing 'bronzed' reflections where ink has been laid.

Corrective Action

- Use the Full set of inks option.

Black and white prints do not look neutral

Consider using the Gray and Black inks only. See Print in gray shades.

Horizontal lines at the end of a cut sheet print

There is a type of defect that only affects the end of a print, within approximately 30 mm of the trailing edge of the paper. Some very thin horizontal lines may be seen across the print.

Corrective Action

- 1 Print the Service Image Diagnostics Print, and clean any printheads that need cleaning. Reprint the job in case the problem has been solved.
- 2 Try printing with roll paper.
- 3 Try using larger margins around the image.

Vertical lines of different colors

The print has vertical bands of different colors along it.

Corrective Action

- 1 Use thicker paper, choosing from the recommended paper types such as HP Heavyweight Coated Paper and HP Super Heavyweight Paper.
- 2 Use higher print quality settings.

White spots on the print

White spots are seen on the print. This is probably due to paper fibers, dust, or loose coating material.

Corrective Action

- 1 Clean the paper manually with a brush before printing, to remove any loose fibers or particles.
- 2 Always keep the cover of the printer closed.
- 3 Protect paper rolls and sheets by storing them in bags or boxes.

Problems with Color Accuracy

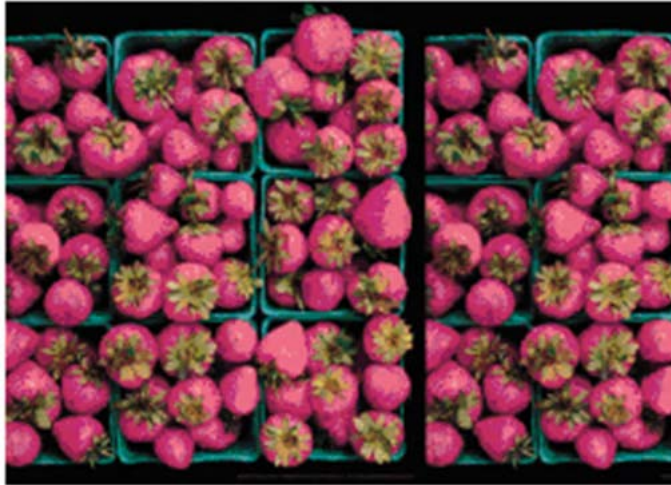

Corrective Action

- 1 Ensure that the paper type being used has been color calibrated, which will give color consistency from print to print, and from Printer to Printer.
- 2 Check that printing is on the correct side of the paper.
- 3 Check that the appropriate print quality settings are being used.
- 4 Select suitable options in the application (refer to the User's Guide for more information).
- 5 Print the Service Image Diagnostics Print, and clean any printheads that need cleaning. Reprint the job in case the problem has been solved.

Color accuracy using EPS or PDF images in page layout applications

Page layout applications such as Adobe InDesign and QuarkXPress do not support color management of EPS, PDF, or grayscale files.

If these types of files have to be used, try to ensure that the EPS, PDF, or grayscale images are already in the same color space that is intended to be used later on in Adobe InDesign or QuarkXPress. For instance, if the final objective is to print the job in a press that follows the SWOP standard, at the time of creating the EPS, PDF or grayscale the image should be converted into SWOP.

Output Only Contains a Partial Print

If the output that was expected only contains a partial image, then try the following to resolve the problem:

- 1 Was the **Cancel** key pressed before all the data was received by the Printer? If so, send the file again and make sure that the **Cancel** key is not pressed.
- 2 The **I/O Timeout** setting may be too short. Increase the I/O timeout setting (Setup Menu/I/O Setup/IO Timeout) and then send the file again.

- 3 There might be a communications problem between the Printer and Computer. Check the USB or network cable between the computer and the Printer to make sure it is not damaged and is connected correctly.
- 4 Make sure that the software settings are correct for the current page size (e.g. long-axis prints).
- 5 If network software is being used, make sure it has not timed out.

Problems with Image Clipping

This normally indicates a discrepancy between the actual printable area on the loaded paper and the printable area as understood by the software. This kind of problem can often be identified before printing by previewing the print.

- Check the actual printable area for the paper size that is loaded.
printable area = paper size – margins
- Check what the software understands to be the printable area (which it may call “printing area” or “imageable area”). For example, some software applications assume standard printable areas that are larger than those used in this Printer.
- If a custom page size with very narrow margins has been defined, the printer may impose its own minimal margins, clipping the image slightly. Consider using a larger paper size, or border less printing.
- If the image contains its own margins, it may be possible to print it successfully by using the Clip Contents by Margins option.
- If a very long image needs to be printed on a roll, check that the software is capable of printing an image of that size.
- The page may have been rotated from portrait to landscape on a paper size that is not wide enough.
- If necessary, change the printable area in the software.

Another Possible Explanation

Some applications, such as Adobe Photoshop, Adobe Illustrator, and CorelDRAW, use an internal 16-bit coordinate system which means that they cannot handle an image of more than 32,768 pixels. If you try to print an image larger than this from these applications, the bottom of the image will be clipped. In this case, the only way to print the whole image is to reduce the resolution so that the whole image requires fewer than 32,768 pixels. The HP-GL/2 printer driver contains an option called **Compatibility with 16-bit applications**, which can be used to reduce the resolution of such images automatically. This option can be found option in the Advanced tab, under Document Options > Printer Features.

Some objects are missing from the printed image

Large quantities of data may be necessary to print a high-quality large-format print job, and in some specific workflow there may be issues that can lead to some objects missing from the output.

Corrective Action

- In the Advanced tab, select Document options, Printer features, and set Send job as bitmap to Enabled (HP-GL/2 driver only).
- In the Advanced tab, select Document options, Printer features, and set 16-bit App. Compatibility to Enabled.
- In the Advanced tab, select Document options, Printer features, and set Max. Application resolution to 300.

The above settings are mentioned for troubleshooting purposes and may adversely affect the final output quality or the time necessary to generate the print job. Therefore, they should be restored to their default values if they do not help to solve the problem.

When working under Mac OS, the above settings are not available. Instead, try reducing the resolution of bitmap images in the application software being used.

A PDF file is clipped or objects are missing

In older versions of Adobe Acrobat or Adobe Reader, large PDF files could be clipped or lose some objects when printing with the HP-GL/2 driver at high resolution. Upgrade the Adobe Acrobat or Adobe Reader software to the latest version. From version 7 onwards, these problems should be solved.

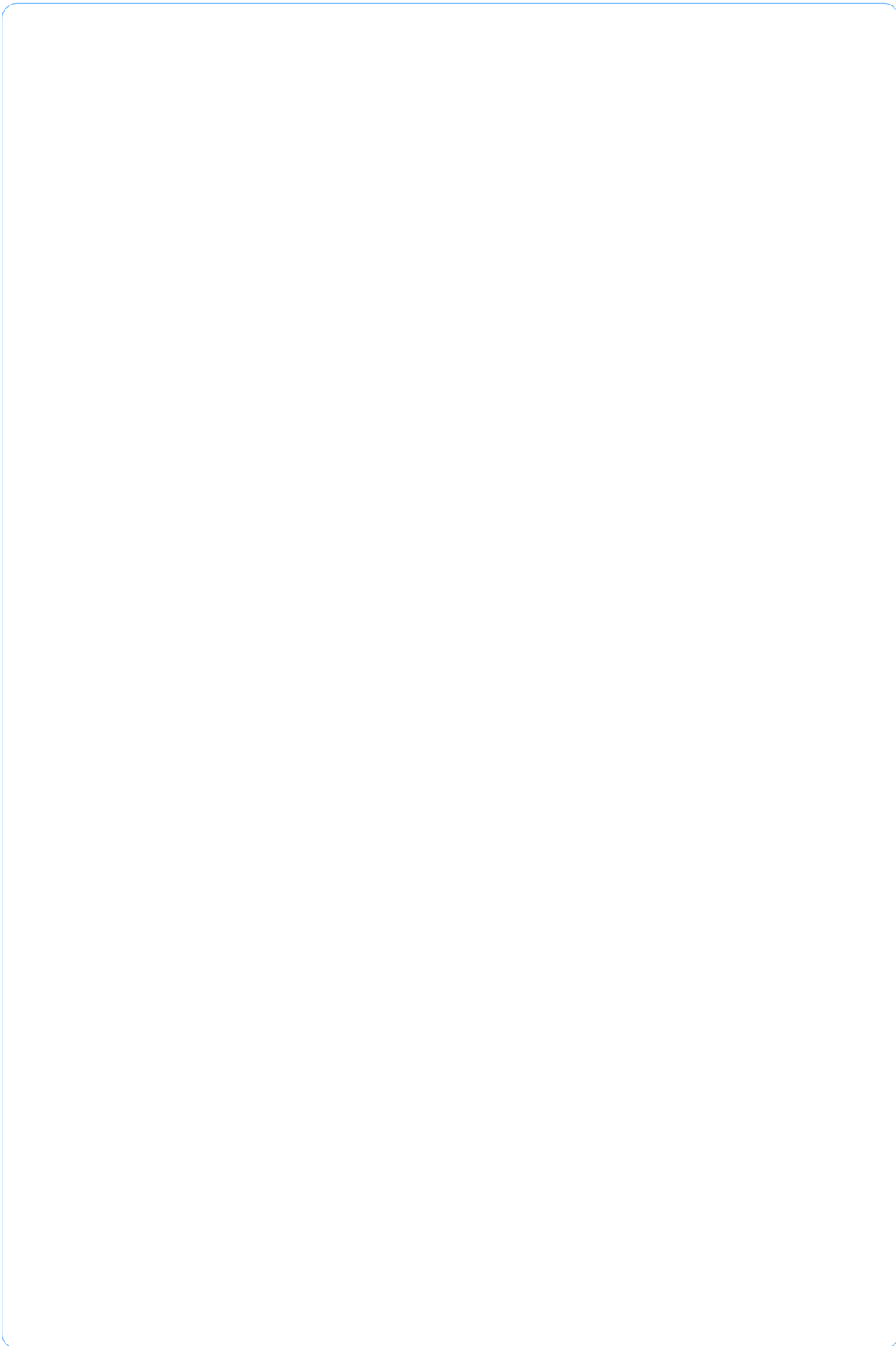

Parts and Diagrams

7

Printer Support	7-2
Center Covers (Front)	7-4
Center Covers (Rear)	7-6
Right Cover	7-8
Left Cover	7-10
Right Hand Assemblies	7-12
Left Hand Assemblies	7-14
Carriage Assembly	7-16
Scan-Axis Assemblies	7-18
Paper Path Assemblies (Front)	7-20
Paper Path Assemblies (Rear)	7-22
Miscellaneous Parts	7-24

Printer Support

Reference on Figure	HP Part Number	Part Description	Printer Model	Size	Page ^a
1	Q5669-60718	Leg Cover	All	All	N/A
2	Q5669-60716	Legs Assembly	All	All	N/A
3	Q5669-60715	Foot Assembly	All	All	N/A
4	Q5669-60719	Bin Assembly (Includes the Bin Support)	All	24 inch	N/A
	Q5669-60185			44 inch	N/A
5	Q5669-60717	X-Brace Assembly	All	24 inch	N/A
	Q5669-60184			44 inch	N/A
-	Q5669-60730	Hardware Kit (Includes screws for Legs Assembly)	All	All	N/A

^a Refers to the page in the Removal and Installation Chapter



Figure 7-1: Printer Support

Center Covers (Front)

Reference on Figure	HP Part Number	Part Description	Printer Model	Size	Page ^a
1	Q5669-60662	Window	All	24 inch	8-4
	Q6659-60172			44 inch	
2	Q5669-60656	Z3100/Z2100 Top Cover	All	24 inch	8-42
	Q6659-60168			44 inch	
3	Q5669-60675	Window Position Sensor	All	All	8-45
4	Q5669-60658	Media Output Assembly	All	24 inch	8-8
	Q6659-60169			44 inch	
5	Q5669-60651	Front Cover	Z2100	24 inch	8-7
	Q6659-60165			44 inch	
	Q5669-67001		Z3100	24 inch	
	Q6659-67001			44 inch	
6	Q6675-60060	Front Panel	Z2100	All	8-40
	Q5669-60714		Z3100		

^a Refers to the page in the Removal and Installation Chapter

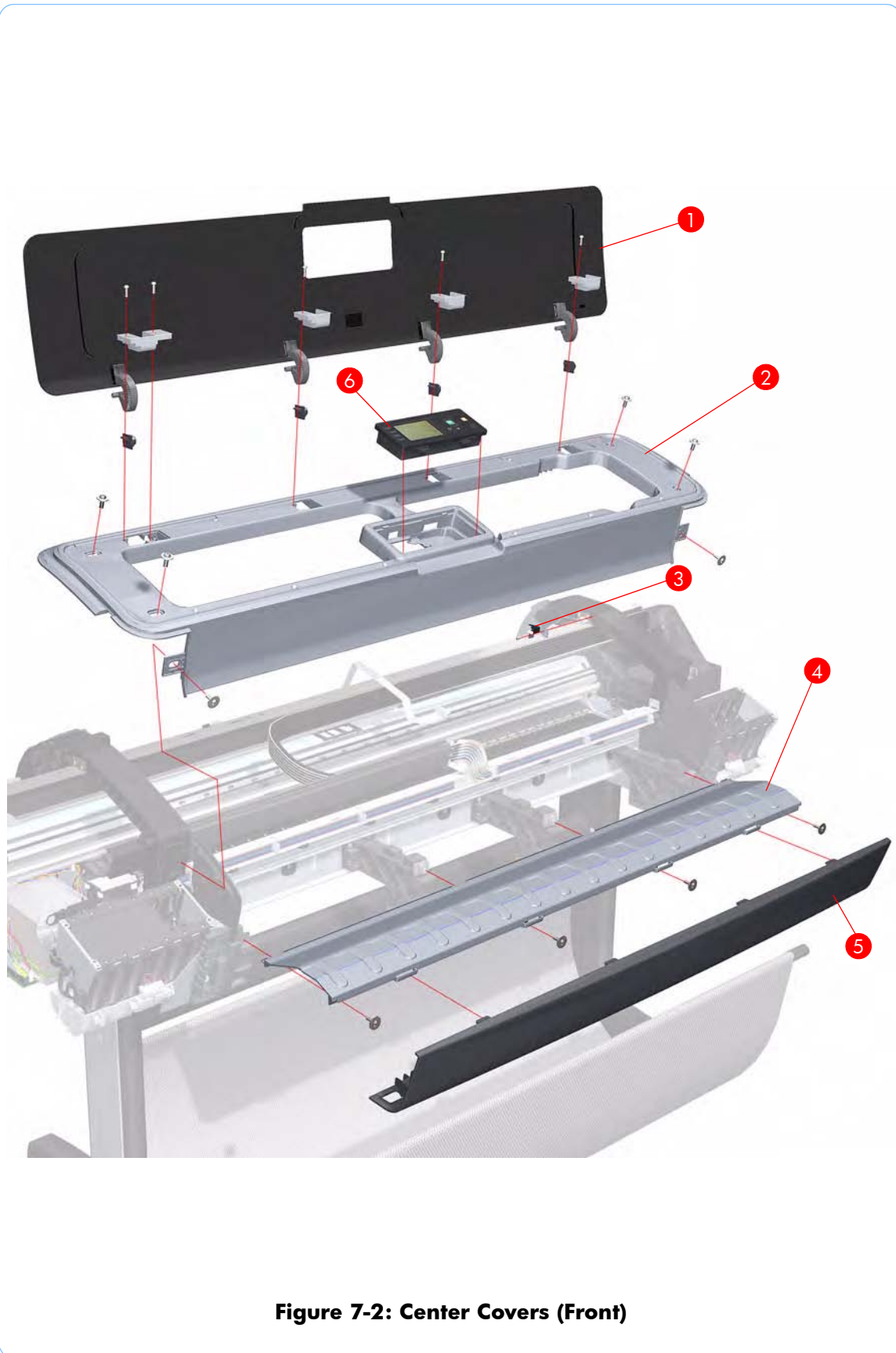

Figure 7-2: Center Covers (Front)

Center Covers (Rear))

Reference on Figure	HP Part Number	Part Description	Printer Model	Size	Page ^a
1	Q5669-60660	Rear Tray Supports	All	All	8-36
2	Q5669-60661	Clean Out Assembly	All	24 inch	8-68
	Q6659-60171			44 inch	
3	Q5669-60676	Out Of Paper Sensor	All	All	8-69
4	Q5669-60659	Rear Tray	All	24 inch	8-28
	Q6659-60170			44 inch	
5	Q5669-60650	Rear Cover	All	24 inch	8-29
	Q6659-60164			44 inch	

a Refers to the page in the Removal and Installation Chapter

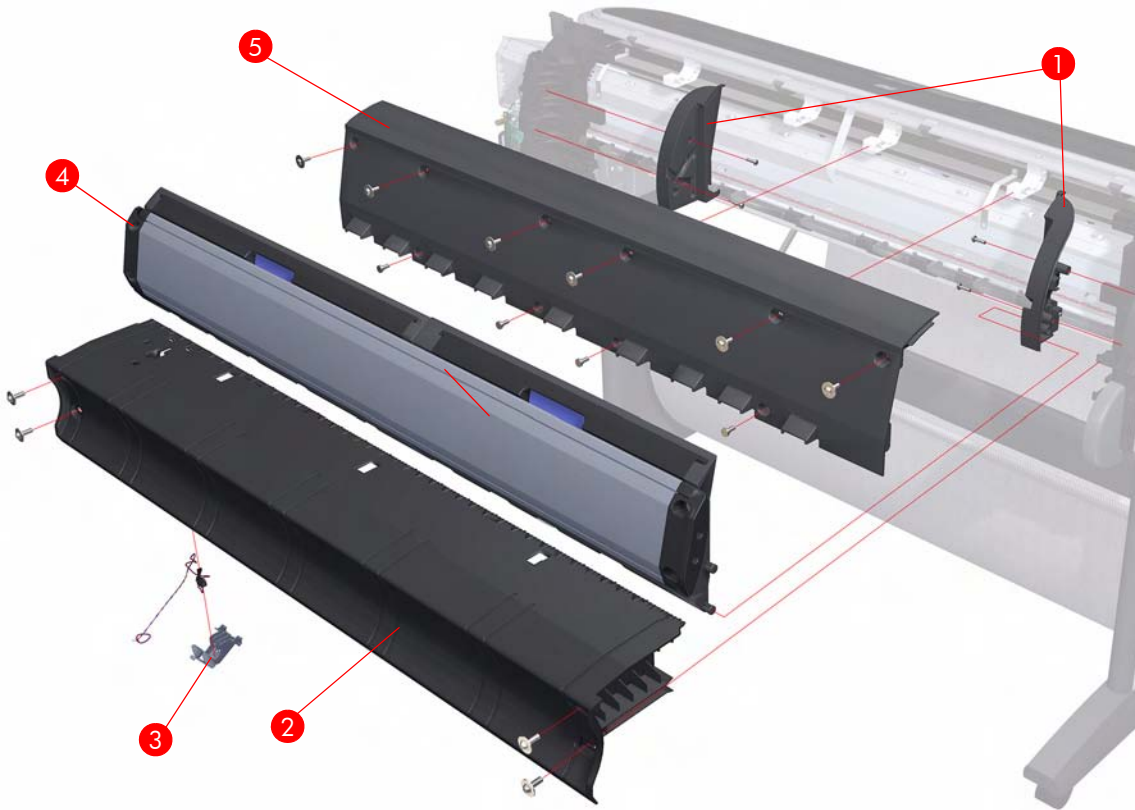

Figure 7-3: Center Covers (Rear)

Right Cover

Reference on Figure	HP Part Number	Part Description	Printer Model	Size	Page ^a
1	Q6675-60015	Right Cover (without Right Ink Cartridge Door)	Z2100	All	8-18
	Q5669-60653		Z3100		
2	Q5669-60657	Left Front Trim/Right Front Trim (Left not shown)	All	All	8-10
3	Q6675-60017	Right Ink Cartridge Door	Z2100	All	8-14
	Q5669-60655		Z3100		

a Refers to the page in the Removal and Installation Chapter

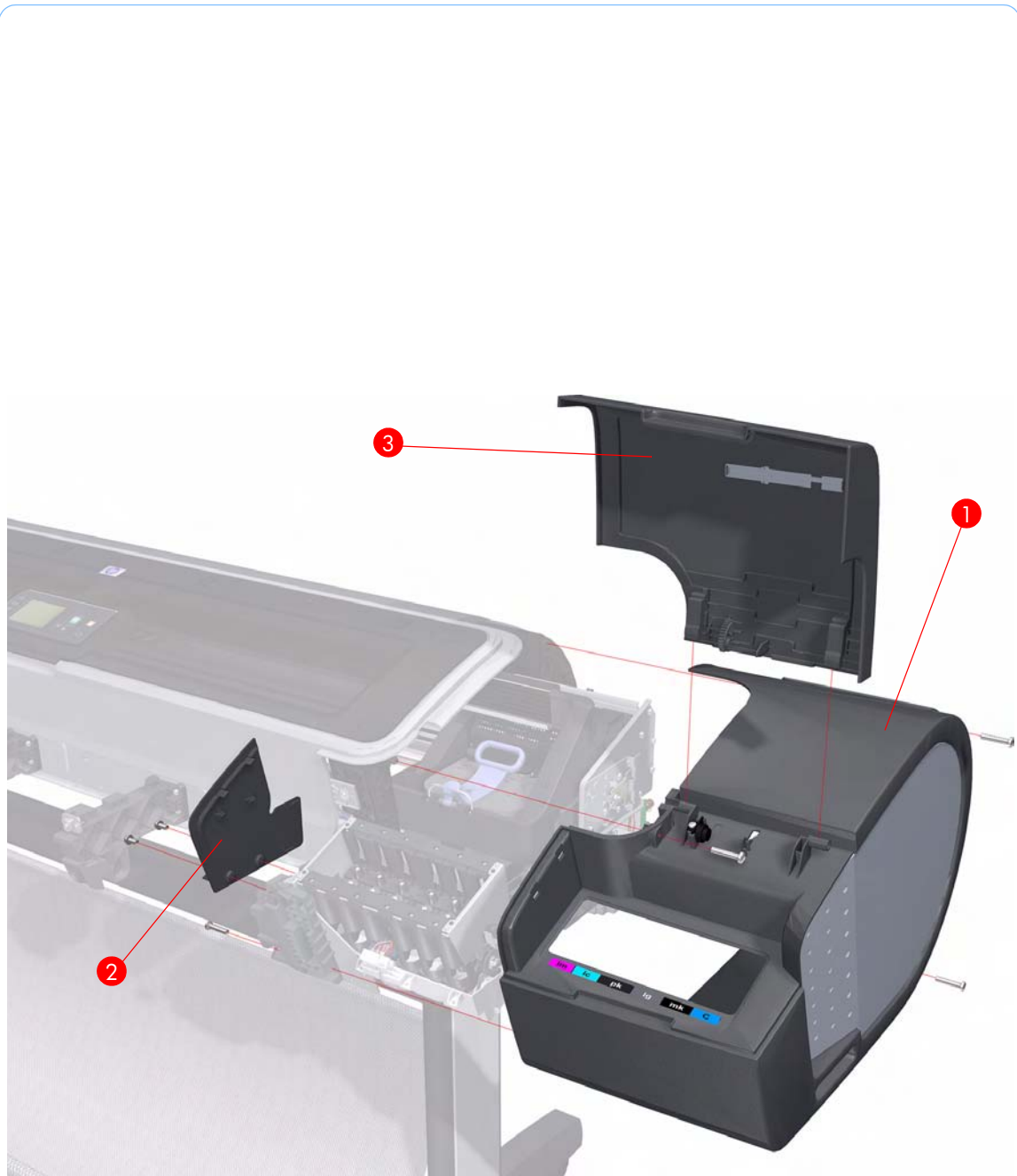

Figure 7-4: Right Cover

Left Cover

Reference on Figure	HP Part Number	Part Description	Printer Model	Size	Page ^a
1	Q6675-60016	Left Ink Cartridge Door	All	All	8-16
2	Q5669-60657	Left Front Trim/Right Front Trim (Right not shown)	All	All	8-12
3	Q6675-67003	Left Side Panel	Z2100	All	8-21
	Q5669-67003		Z3100		
4	Q6675-60014	Left Cover (without Left Ink Cartridge Door)	Z2100	All	8-21
	Q5669-60652		Z3100		

^a Refers to the page in the Removal and Installation Chapter

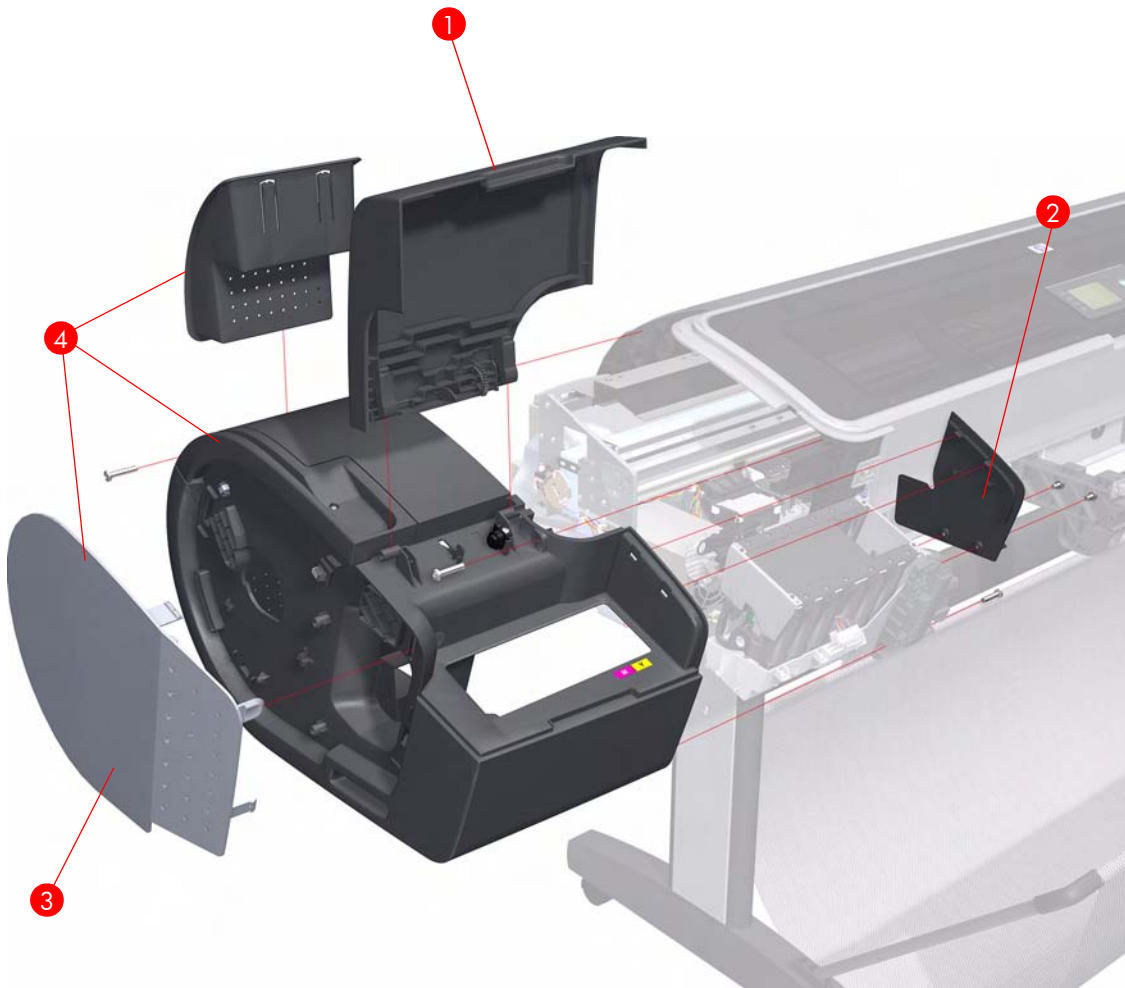

Figure 7-5: Left Cover

Right Hand Assemblies

Reference on Figure	HP Part Number	Part Description	Printer Model	Size	Page ^a
1	Q6675-60043	Carriage Rail Oiler	All	All	8-101
2	Q5669-60677	Pen to Paper Space (PPS) Solenoid	All	All	8-63
3	Q5669-60674	Scan-Axis Motor	All	All	8-97
4	Q6675-60018	Z3100/Z2100 PrintMech PCA	All	All	8-61
5	Q5669-60667	Service Station Spittoon	All	All	8-51
6	Q5669-60665	Primer Assembly	All	All	8-57
7	Q5669-60664	Aerosol Fan Assembly	All	All	8-56
8	Q6675-60059	Service Station (Includes Drop Detector, Aerosol Fan Assembly, Primer Assembly, and Right Spittoon)	Z2100	All	8-51
	Q5669-67002		Z3100		
9	Q5669-60666	Drop Detector	All	All	8-55
10	Q6675-60020	Right Ink Supply Station	Z2100	All	8-124
	Q5669-60670		Z3100		

^a Refers to the page in the Removal and Installation Chapter

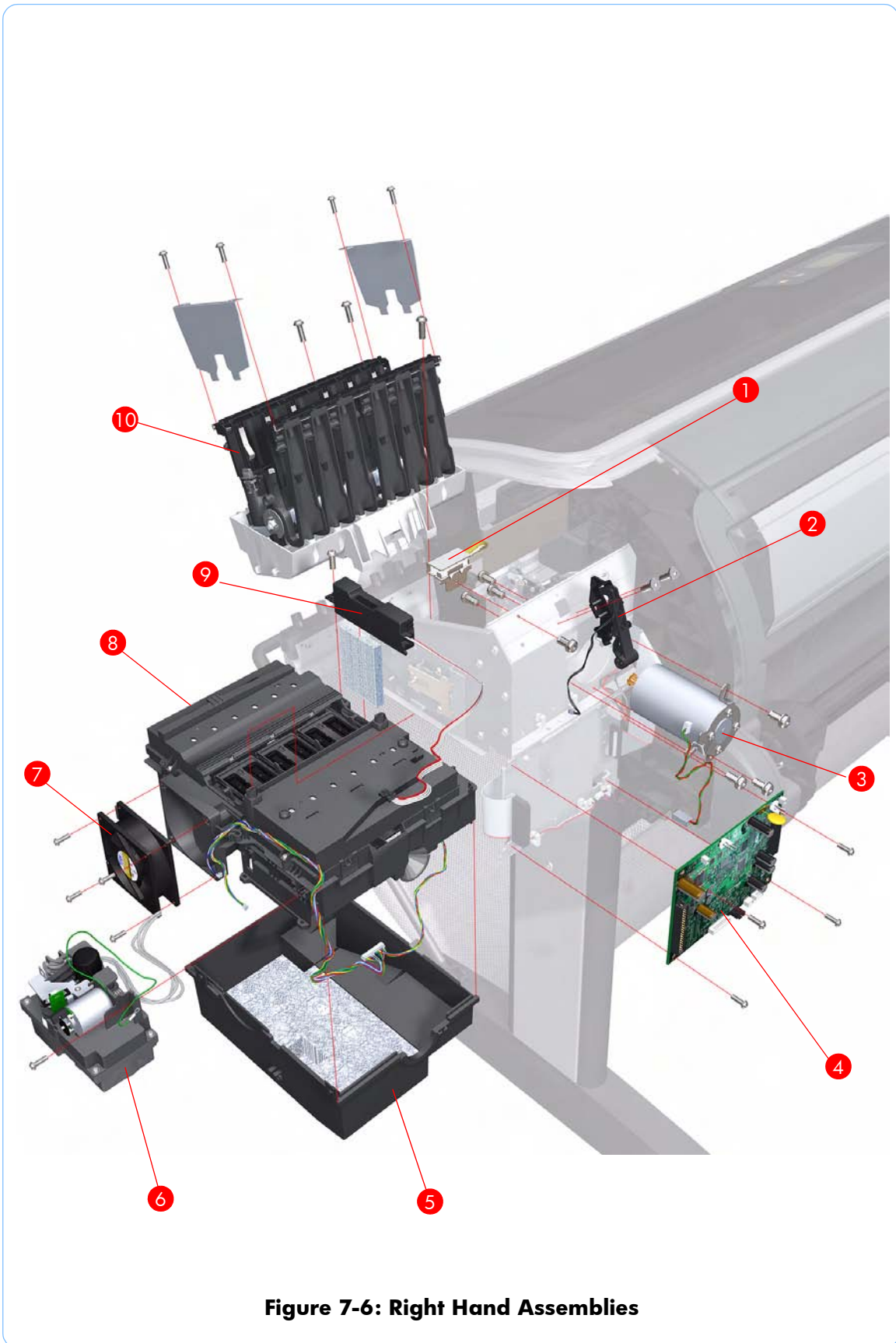

Figure 7-6: Right Hand Assemblies

Left Hand Assemblies

Reference on Figure	HP Part Number	Part Description	Printer Model	Size	Page ^a
1	Q6675-60019	Left Ink Supply Station	Z2100	All	8-128
	Q5669-60669		Z3100		
2	Q5669-60697	Starwheel Motor	All	All	8-176
3	Q5669-60703	Encoder Sensor	All	All	8-152
4	Q5669-60702	Encoder Disk	All	All	8-152
5	Q5669-60700	Media Advance Transmission	All	All	8-155
6	Q5669-60704	Media Advance Drive	All	All	8-155
7	Q5669-60693	Power Supply Unit (PSU) Assembly	All	All	8-144
8	Q6675-60023	Z3100/Z2100 Main PCA with Power Supply Unit (PSU) Assembly	All	24 inch	8-144
	Q6677-60008			44 inch	
9	Q6675-60024	Formatter	Z2100	All	8-51
	Q5669-60695		Z3100		
10	Q5669-60705	Media Lever	All	All	8-30
11	Q5669-60706	Media Lever Position Sensor	All	All	8-33
12	Q5669-60709	Left Spittoon	All	All	8-150

^a Refers to the page in the Removal and Installation Chapter

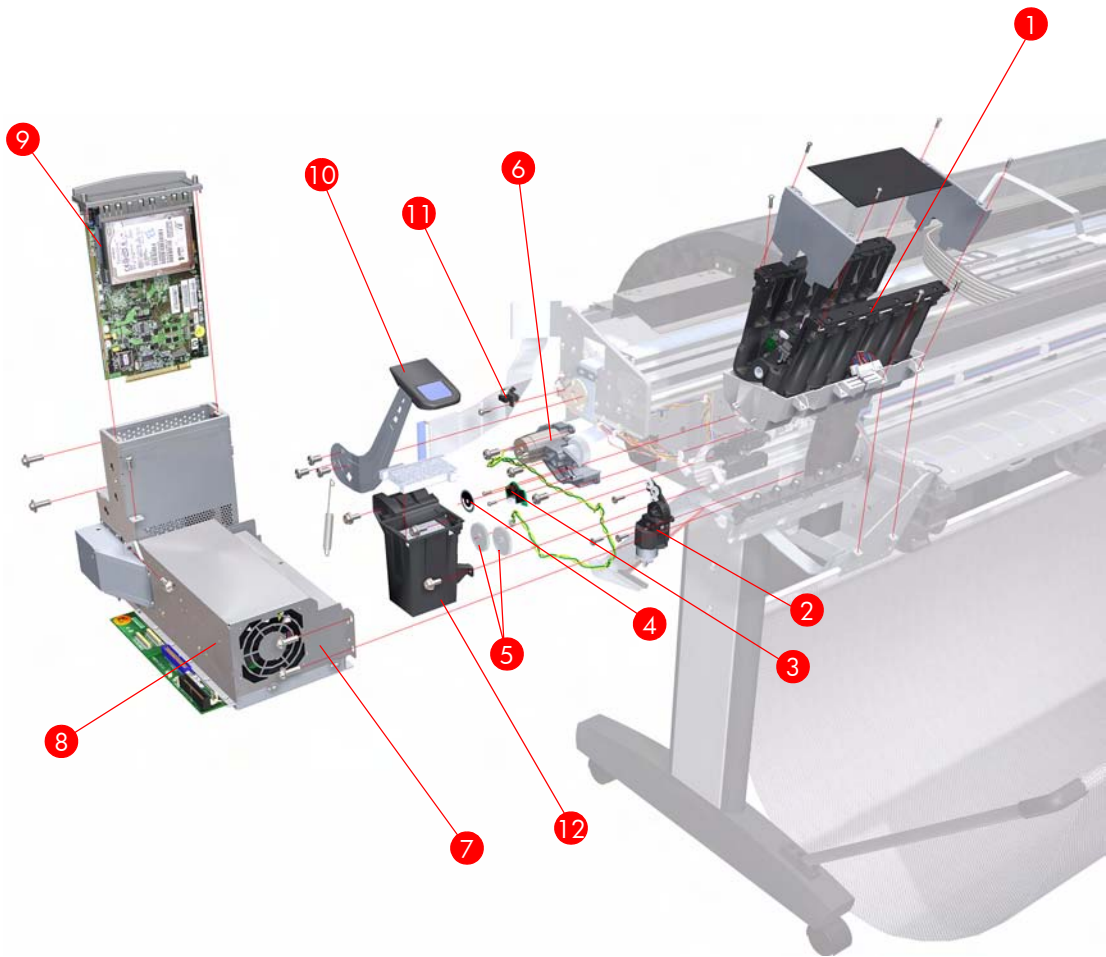

Figure 7-7: Left Hand Assemblies

Carriage Assembly

Reference on Figure	HP Part Number	Part Description	Printer Model	Size	Page ^a
1	Q5669-60689	Carriage PCA Covers	All	All	8-85
2	Q5669-60685	Carriage Latch	All	All	8-114
3	Q5669-60686	Carriage Cover (includes Carriage Latch)	All	All	8-114
4	Q5669-60682	Carriage PCA	All	All	8-119
5	Q5669-60687	Carriage Rear Bushing	All	All	8-94
6	Q5669-60683	Line Sensor	All	All	8-109
7	Q5669-60687	Color Sensor (ESP)	All	All	8-103
-	Q6675-60022	Z3100 Photo Printer Carriage Assembly (includes: Line Sensor, Carriage Latch, Carriage Cover, Carriage PCA, and Color Sensor (ESP))	Z2100	All	8-85
	Q5669-60680		Z3100		

^a Refers to the page in the Removal and Installation Chapter

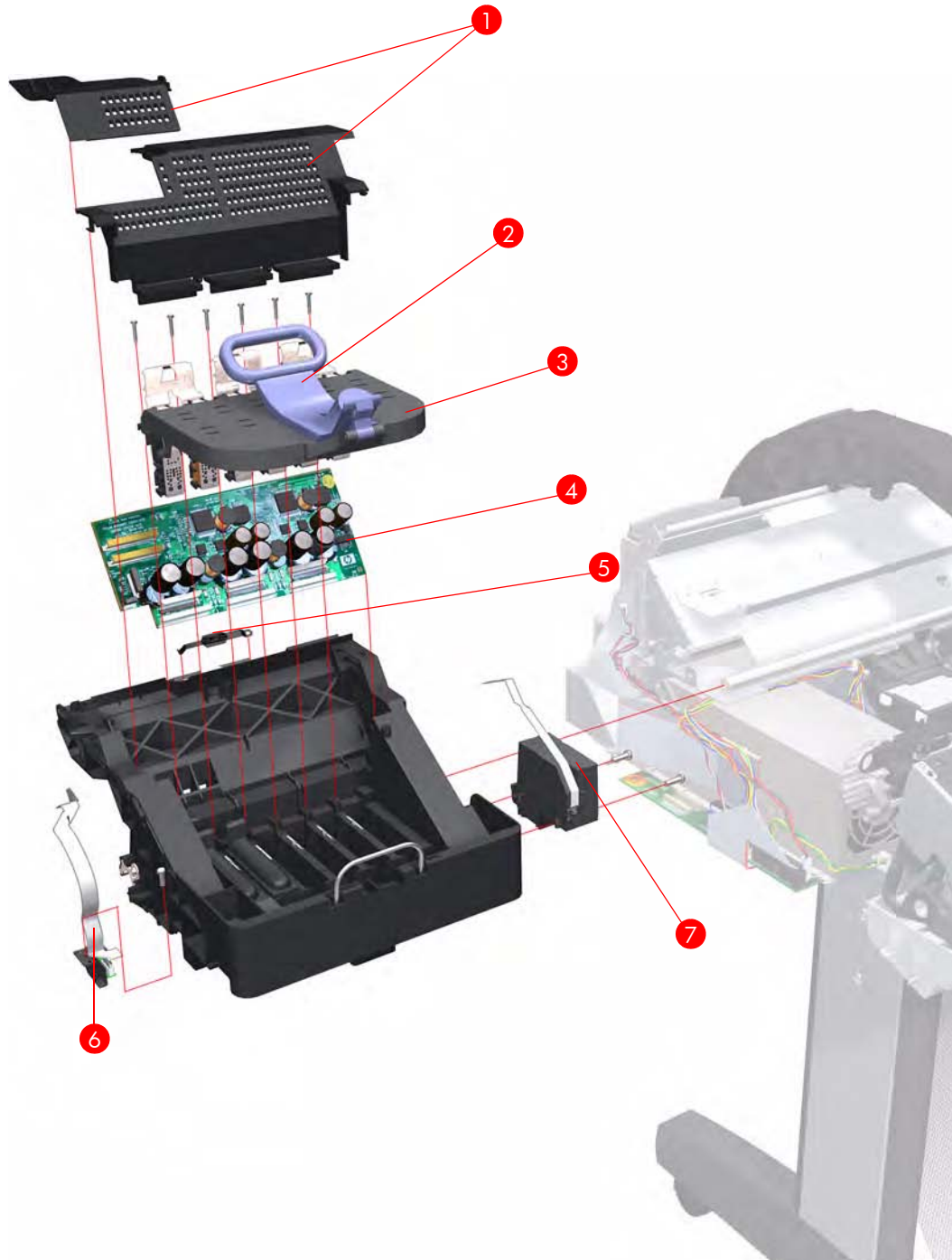

Figure 7-8: Carriage Assembly

Scan-Axis Assemblies

Reference on Figure	HP Part Number	Part Description	Printer Model	Size	Page ^a
1	Q6675-60021	Ink Supply Tubes	Z2100	24 inch	8-132
	Q5669-60671		Z3100		
	Q6677-60007		Z2100	44 inch	
	Q6659-60174		Z3100		
2	Q6675-60071	Encoder Strip (including Encoder Strip Spring and Nut)	All	24 inch	8-74
	Q6677-60024			44 inch	
3	Q5669-60673	Belt Assembly	All	24 inch	8-96
	Q6659-60175			44 inch	
4	Q5669-60672	Belt Tensioner	All	All	8-96
5	Q5669-60681	Trailing Cable	All	24 inch	8-74
	Q6659-60177			44 inch	
-	Q5669-60679	Encoder Strip - 50 units	All	24 inch	8-74
	Q6659-60176			44 inch	

^a Refers to the page in the Removal and Installation Chapter

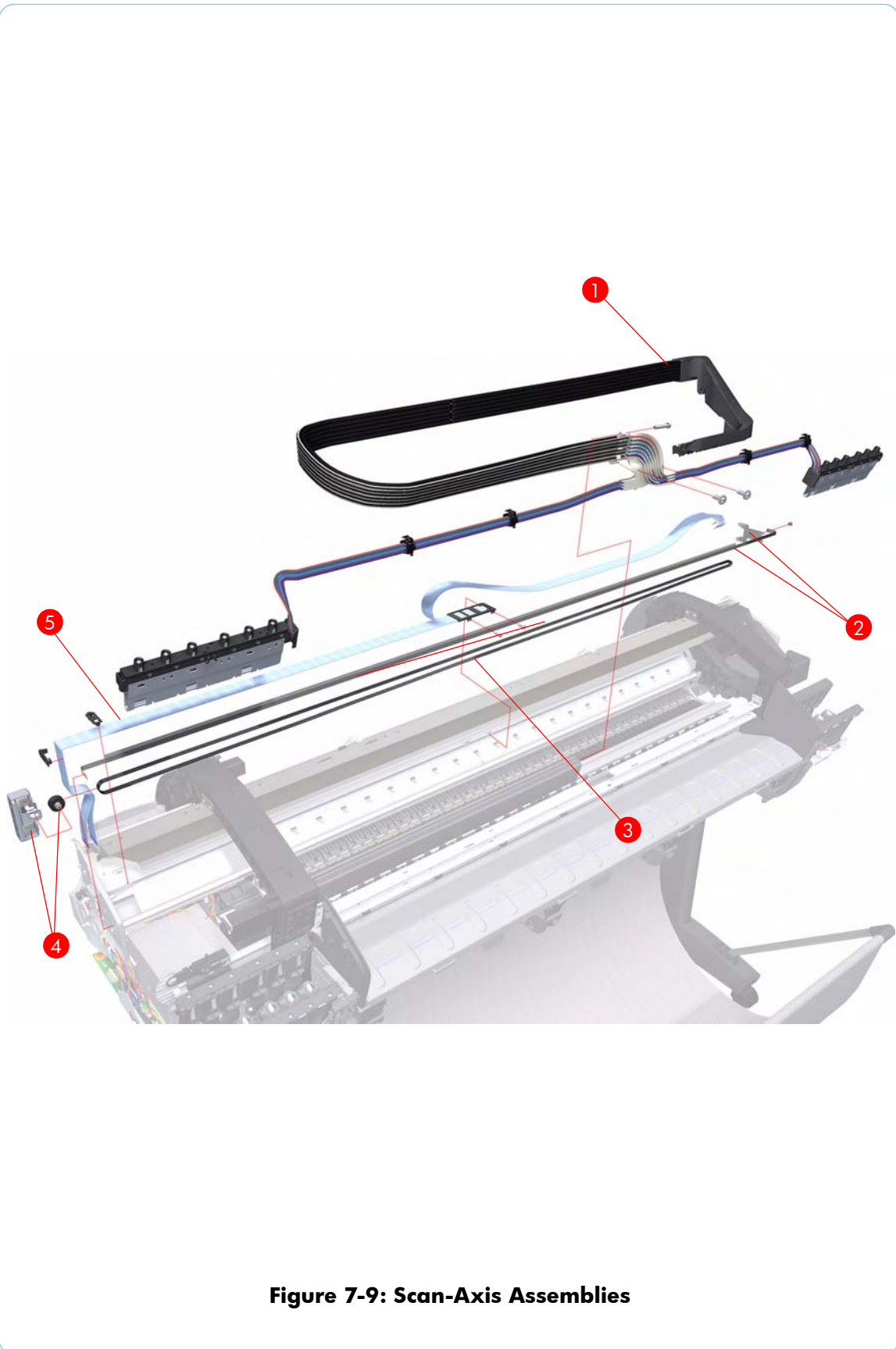

Figure 7-9: Scan-Axis Assemblies

Paper Path Assemblies (Front)

Reference on Figure	HP Part Number	Part Description	Printer Model	Size	Page ^a
1	Q5669-60696	Starwheel Assembly	All	24 inch	8-144
	Q6659-60180			44 inch	
2	Q6675-60042	Print Zone Overdrive	All	24 inch	8-146
	Q6677-60018			44 inch	
3	Q5669-60698	Starwheel Lifter	All	All	8-171
4	Q5669-60713	Cutter Assembly	All	All	8-35
5	Q5669-60701	Full Bleed Foam Kit	All	24 inch	8-178
	Q6659-60182			44 inch	

a Refers to the page in the Removal and Installation Chapter

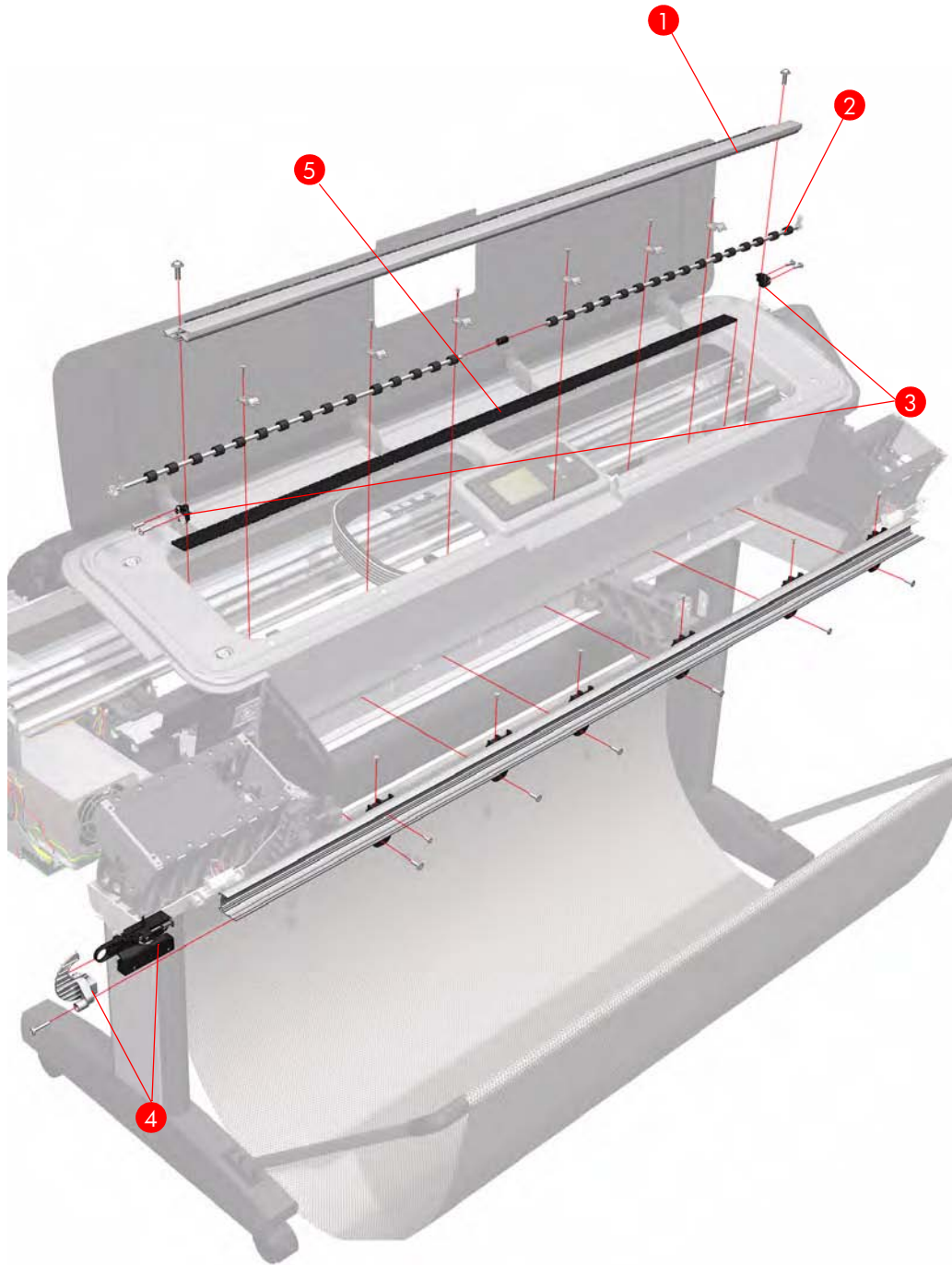

Figure 7-10: Paper Path Assemblies (Front)

Paper Path Assemblies (Rear)

Reference on Figure	HP Part Number	Part Description	Printer Model	Size	Page ^a
1	Q5669-60708	Pinchwheel Roller	All	All	8-170
2	Q5669-60707	Pinchwheel Assembly	All	All	8-165
3	Q6677-60019	Left Roll Guide	All	44 inch	8-72
4	Q5669-60711	Left Spindle Holder	All	All	8-66
5	Q5669-60710	Spindle	All	24 inch	8-65
	Q6659-60183			44 inch	
6	Q5669-60712	Right Spindle Holder	All	All	8-67
7	Q5669-60746	Right Roll Guide	All	All	8-73
8	Q5669-60699	Media Advance Roller	All	24 inch	8-159
	Q5669-60181			44 inch	

^a Refers to the page in the Removal and Installation Chapter

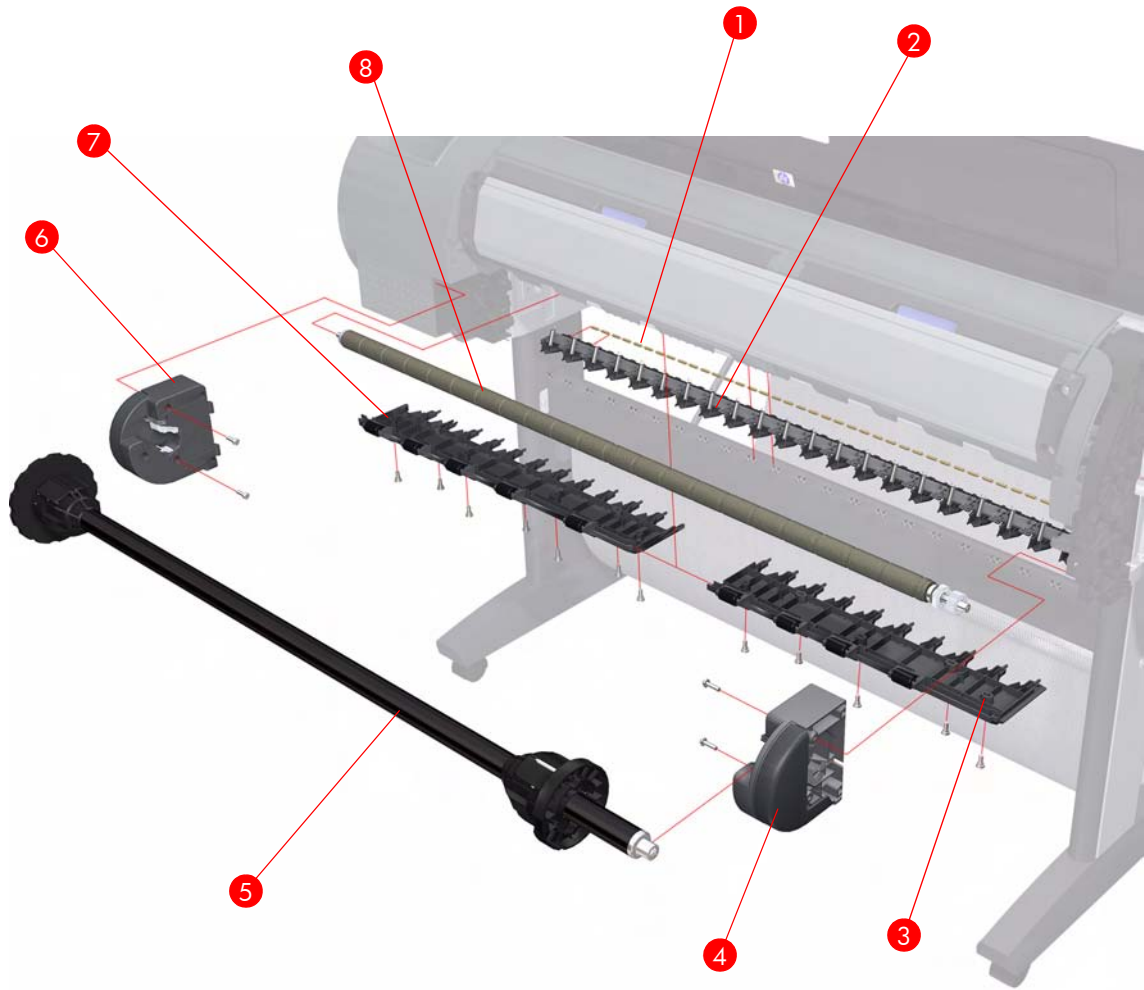

Figure 7-11: Paper Path Assemblies (Rear)

Miscellaneous Parts

HP Part Number	Part Description	Printer Model	Size
Q6675-60032	Preventive Maintenance Kit #1	Z2100	24 inch
Q5669-60748		Z3100	
Q6677-60015		Z2100	44 inch
Q6659-60189		Z3100	
Q6675-67012	Preventive Maintenance Kit #2	Z2100	All
Q5669-67008		Z3100	
Q5669-60722	Preventive Maintenance Kit #3	All	All
Q5669-60690	Flex Contacts Cleaning Tool	All	All
Q5669-60691	Pinchwheel Insertion Tool	All	All
Q5669-60692	Lubrication Kit	All	All
Q6675-60068	Serial Number Label	All	All
Q6675-67004	Ink System Purgers (6 Units)	All	All
Q6675-67005	Ink System Purgers (100 Units)	All	All
Q6675-67006	Double Sided Adhesive Pad	All	All
Q6675-67008	Z3100/Z2100 Tool Kit	All	All

Removal and Installation

8

Introduction -> 8-2
Window -> 8-4
Covers and Trims 8-7
Media Lever -> 8-30
Media Lever Position Sensor -> 8-33
Rear Tray -> 8-28
Rear Cover -> 8-29
Media Lever -> 8-30
Media Lever Position Sensor -> 8-33
Cutter Assembly -> 8-35
Left Rear Tray Support -> 8-38
Front Panel -> 8-40
Top Cover -> 8-42
Window Position Sensor -> 8-45
Ink Supply Tubes Support Rail -> 8-47
Service Station -> 8-51
Drop Detector -> 8-55
Aerosol Fan Assembly -> 8-56
Primer Assembly -> 8-57
PrintMech PCA -> 8-61
Pen to Paper Space (PPS) Solenoid -> 8-63
Spindle -> 8-65
Left Spindle Holder -> 8-66
Right Spindle Holder -> 8-67
Clean Out Assembly -> 8-68
Out Of Paper Sensor -> 8-69
Left Roll Guide -> 8-72
Right Roll Guide -> 8-73
Encoder Strip (with spring and attachment nut) -> 8-74
Encoder Strip -> 8-77
Trailing Cable -> 8-78
Carriage Assembly -> 8-85
Carriage Rear Bushing -> 8-94
Belt Assembly -> 8-96
Scan-Axis Motor -> 8-97
Carriage Rail Oiler -> 8-101
Color Sensor (ESP) -> 8-103
Line Sensor -> 8-109
Carriage Cover (includes Carriage Latch) -> 8-114
Carriage PCA -> 8-119
Right Ink Supply Station -> 8-124
Left Ink Supply Station -> 8-128
Ink Supply Tubes -> 8-132
Formatter -> 8-140
Electronics Module (Main PCA and PSU) -> 8-141
Starwheel Assembly -> 8-144
Print Zone Overdrive -> 8-146
Left Spittoon -> 8-150
Encoder Disk and Encoder Sensor -> 8-152
Media Advance Drive -> 8-155
Media Advance Roller -> 8-159
Pinchwheel Assembly -> 8-165
Pinchwheel Roller -> 8-170
Left Starwheel Lifter -> 8-171
Right Starwheel Lifter -> 8-173
Starwheel Motor -> 8-176
Full Bleed Foam -> 8-178

Introduction

This chapter is a step-by-step guide to the removal and installation of the key components of the printer. You may find it useful to check off the steps as they are performed. Use the illustrations for each procedure to identify the parts referred to in the text.

The procedures appear in order of removal. The whole machine can be stripped down by starting at the beginning of this chapter and working through the subsequent procedures.

Before using this chapter to remove and install a new component, always make sure that you have performed the relevant service test from Chapter 4. If the test passes you will not need to replace the component.

Safety Precautions

Review the instructions identified by WARNING and CAUTION symbols before you service the printer. Follow these warnings and cautions for your protection and to avoid damaging the printer.

Serious shock hazard leading to death or injury may result if you do not take the following precautions:

- **Ensure that the ac power outlet (mains) has a protective earth (ground) terminal.**
- **Switch the plotter off, and disconnect it from the power source prior to performing any maintenance.**
- **Prevent water or other liquids from running onto electrical components or circuits, or through openings in the module.**

Electrostatic Discharge (ESD) Precautions

To prevent damage to the Printer circuits from high-voltage electrostatic discharge (ESD):

1. Do not wear clothing that is subject to static build-up.
2. Do not handle integrated circuits (ICs) in carpeted areas.
3. Do not remove an IC or a printed circuit assembly (PCA) from its conductive foam pad or conductive packaging until you are ready to install it.
4. Ground (earth) your body while disassembling and working on the Printer.
5. After removing a cover from the Printer, attach an earthing (ground) lead between the PCA common and earth ground. Touch all tools to earth ground to remove static charges before using them on the Printer.
6. After removing any PCA from the Printer, place it on a conductive foam pad or into its conductive packaging to prevent ESD damage to any ICs on the PCA.

Required Tools

All the special tools and equipment required to disassemble, service and repair the Printer are provided in the Z2100/Z3100 Toolkit P/N Q6675-67008. The Z2100/Z3100 Toolkit contains the following tools:

Z2100/Z3100 Toolkit P/N Q6675-67008	
Description/Comments	HP Part Number
13 mm Combination Spanner	Q6675-67011
Alcohol	Q6675-60070
Allen Key #2	Q6675-60041
Cleaning Cloth	9300-2531
Flex Contacts Cleaning Support	Q1271-40384
Handle for Media Advance Drive Adjustment Tool	Q6675-67010
Lubricant Oil	Q6675-60061
Media Advance Drive Adjustment Tool	Q6675-60009
Oil Dispenser	Q6675-60062
Pinchwheel Alignment Tool	Q5669-20595
Pinchwheel Insertion Tool	Q5669-20594
Protective Plastic Gloves	Q6675-60035
Screwdriver	8710-2456
Tweezers	Q6675-60037
Z2100/Z3100 Cleaning Assembly	C6071-60218

You will also need the following standard hand tools:

Standard Tool Requirements	
Description/Comments	Size
Long Torx Screwdriver	1/4 inch drive
Torx Bit (75 mm)	8
	10
	15
	20
Allen Wrench	M2
Philips Screwdriver	1
Pliers	N/A
Snips	N/A
Pipe Spanner	5.5 mm
Flat Bladed Screwdriver	N/A

Window

Removal

Switch off the printer and remove the power cable.



1. Open the Window.

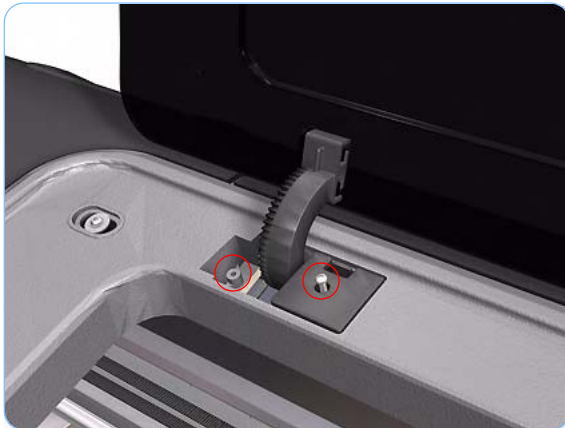

2. Remove one T-15 screw and one T-10 screw that secure each of the four Window hinge locking plates to the Top Cover.



3. Un-clip the four Window hinge locking plates from the Top Cover.

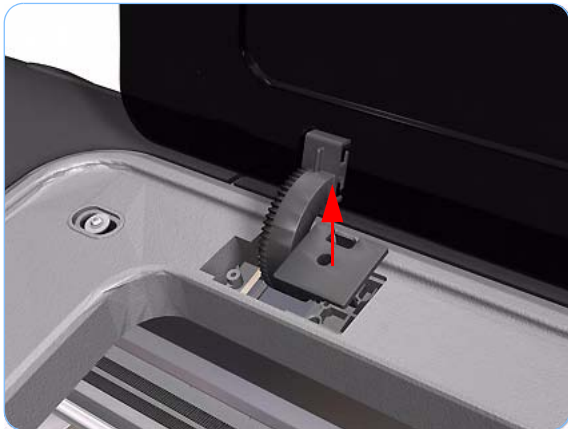

4. Remove the four Window hinge locking plates from the Top Cover.



5. Grip the Window at the left and right edges and move it horizontally towards the right as far as it will go.



6. Pull the Window towards the front to disengage the hinges.



7. Lift the Window vertically out of the printer.

Front Cover

Removal

Switch off the printer and remove the power cable.



1. Squeeze each of the four attachment clips under the Front Cover, to release the cover from the printer.

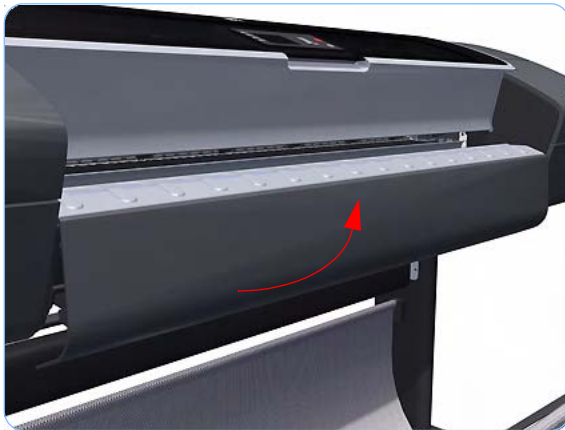

2. Carefully pull the bottom of the Front Cover forwards until you can release it from its attachments.



3. Unhook the Front Cover from the four attachments and remove it from the printer.

Media Output Assembly

Removal

Switch off the printer and remove the power cable.

1. Remove the Front Cover (refer to page 8-7).
2. Remove four T-15 screws that secure the Media Output Assembly to the printer.

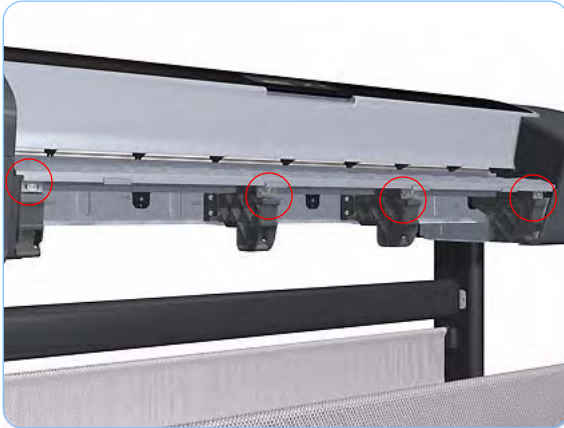

3. Release the four attachment clips.

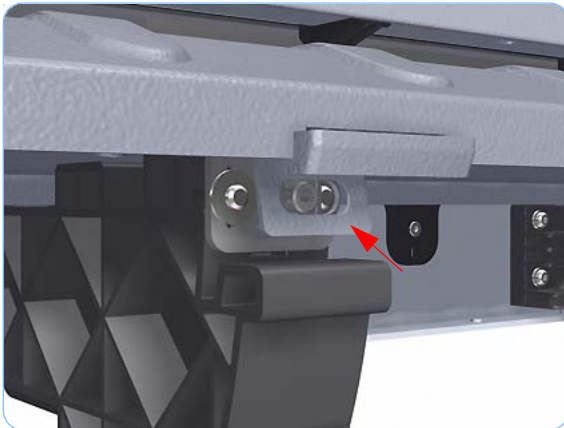

4. Lift the front of the Media Output Assembly.

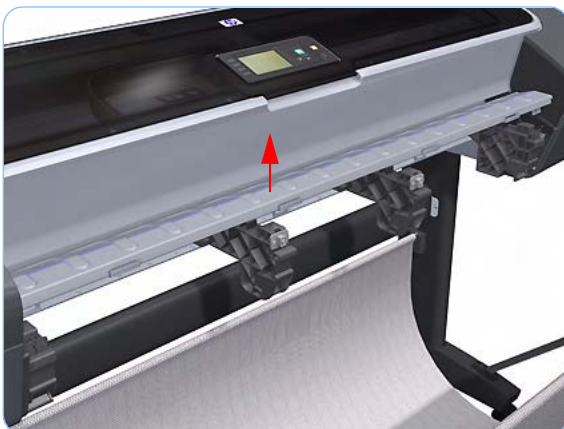



5. Slide the Media Output Assembly forwards out of the printer.

Right Front Trim

Removal

Switch off the printer and remove the power cable.

1. Remove the Front Cover (refer to page 8-7).
2. Remove the Media Output Assembly (refer to page 8-8).
3. Remove two T-15 screws that secure the Right Front Trim to the printer.

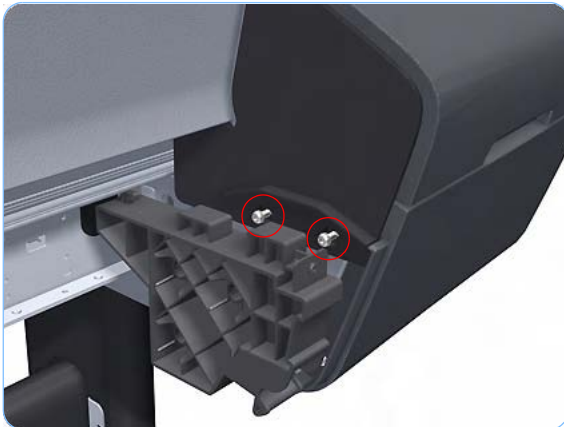

4. Open the Right Ink Cartridge Door.

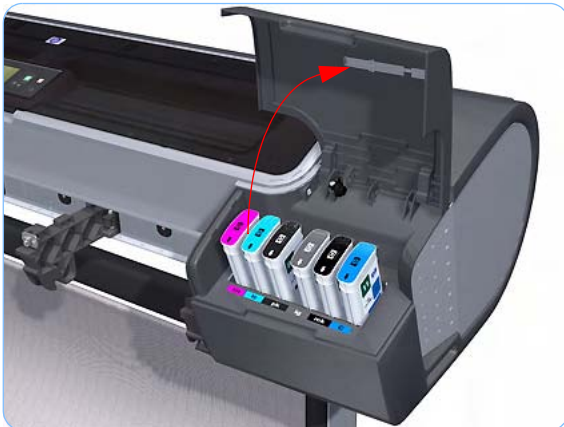

5. Unclip the Right Front Trim.



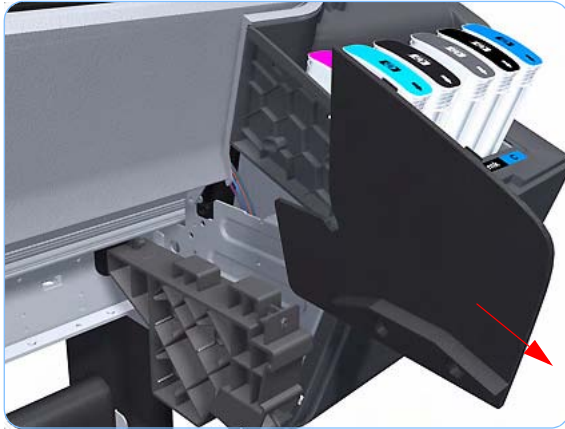

6. Remove Right Front Trim from the printer.

Left Front Trim

Removal

Switch off the printer and remove the power cable.

1. Remove the Front Cover (refer to page 8-7).
2. Remove the Media Output Assembly (refer to page 8-8).
3. Remove two T-15 screws that secure the Left Front Trim to the printer.

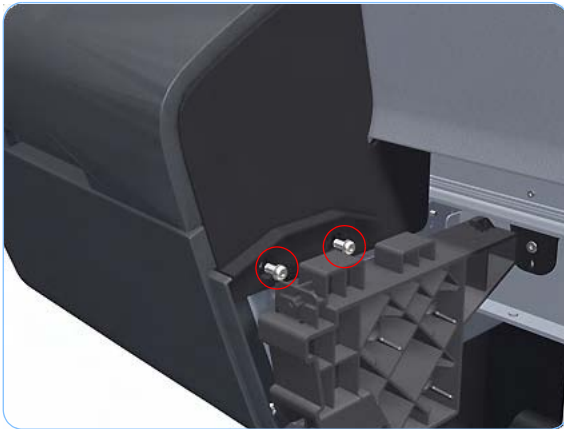

4. Open the Left Ink Cartridge Door.



5. Unclip the Left Front Trim.



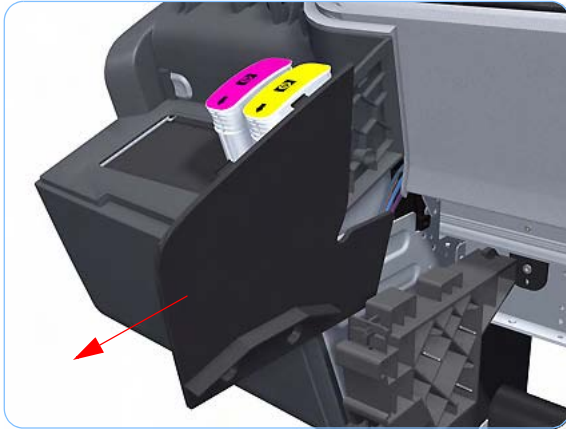

6. Remove Left Front Trim from the printer.

Right Ink Cartridge Door

Removal

Switch off the printer and remove the power cable.



1. Open the Right Ink Cartridge Door.



2. Unclip the right side of the Right Ink Cartridge Door.

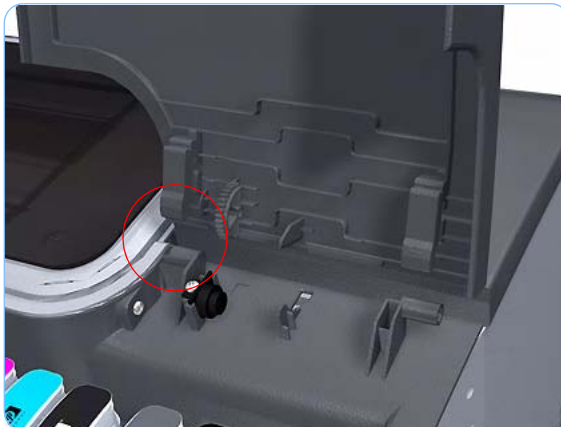

3. Unclip the left side of the Right Ink Cartridge Door.



4. Remove the Right Ink Cartridge Door.

Left Ink Cartridge Door

Removal

Switch off the printer and remove the power cable.



1. Open the Left Ink Cartridge Door.



2. Unclip the left side of the Left Ink Cartridge Door.

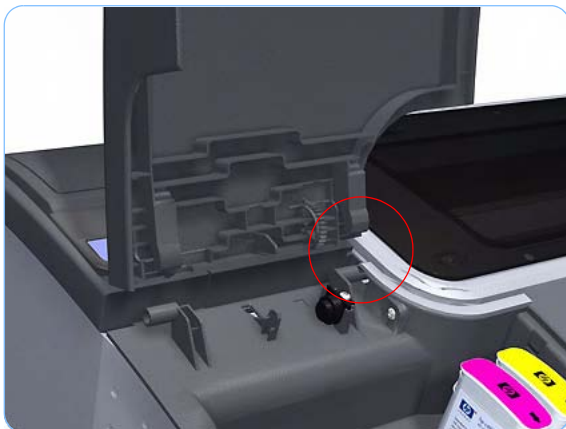

3. Unclip the right side of the Left Ink Cartridge Door.



4. Remove the Left Ink Cartridge Door.

Right Cover

Removal

Switch off the printer and remove the power cable.

1. Remove the Front Cover (refer to page 8-7).
2. Open the Right Ink Cartridge Door.



3. Remove the Ink Cartridges from the printer.



4. Remove one T-15 screw that secures the Right Cover to the printer (at the rear of the Printer).

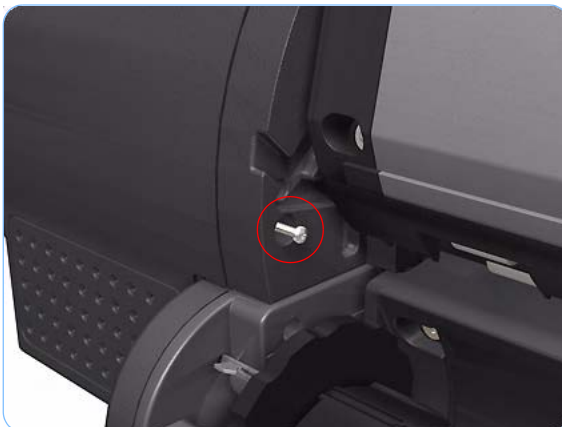

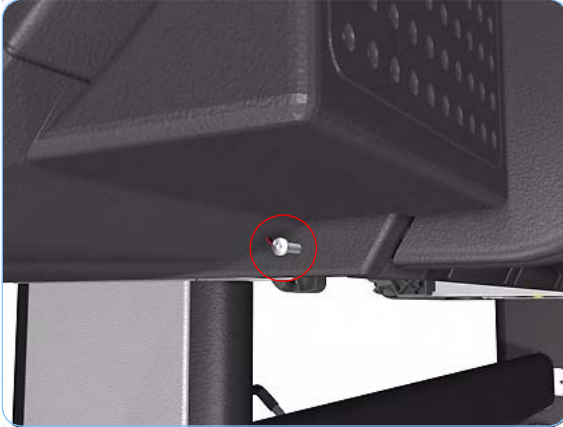

5. Remove one T-15 screw that secures the Right Cover to the printer (at the rear of the Printer).

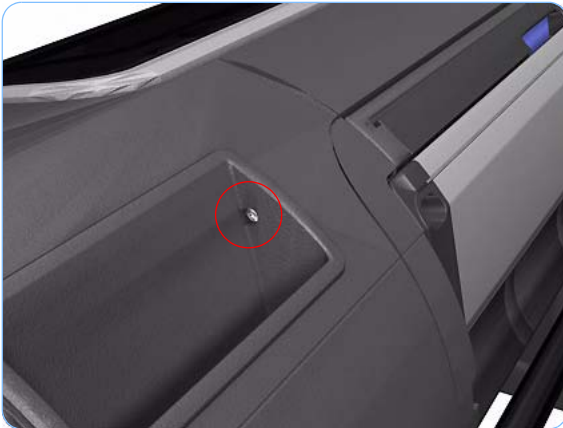

6. Remove one T-15 screw that secures the Right Cover to the printer (at the rear of the printer).

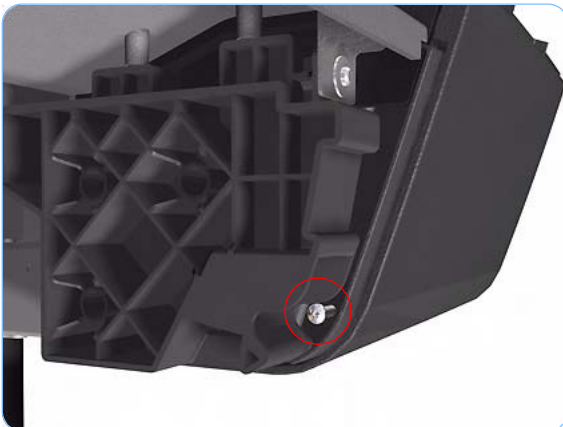

7. Remove one T-15 screw that secures the Right Cover to the printer (accessible under the Front Cover).



- 8.** Remove one T-15 screw that secures the Right Cover to the printer (accessible from within the cartridge bay).



- 9.** Unclip the Right Trim.

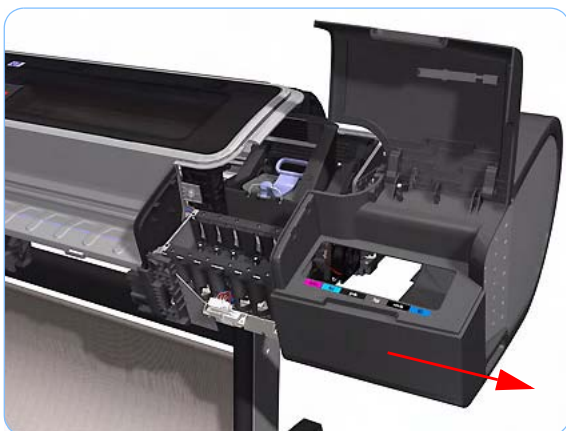

- 10.** Remove the Right Cover from the printer.

Left Cover

Removal

Switch off the printer and remove the power cable.

1. Remove the Front Cover (refer to page 8-7)
2. Open the Left Ink Cartridge Door.

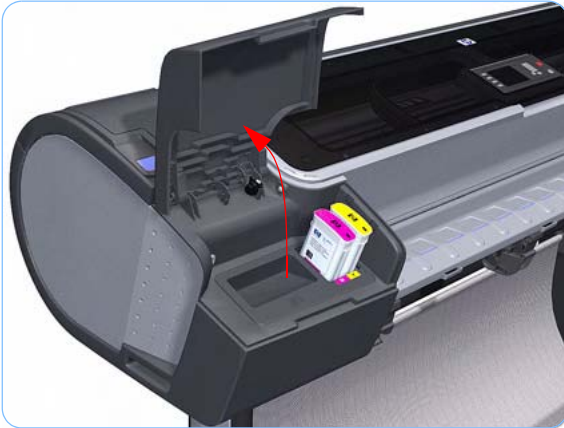

3. Open the Left Ink Cartridge Door.



4. Press the clip to release the Left Cover Finishing Panel.



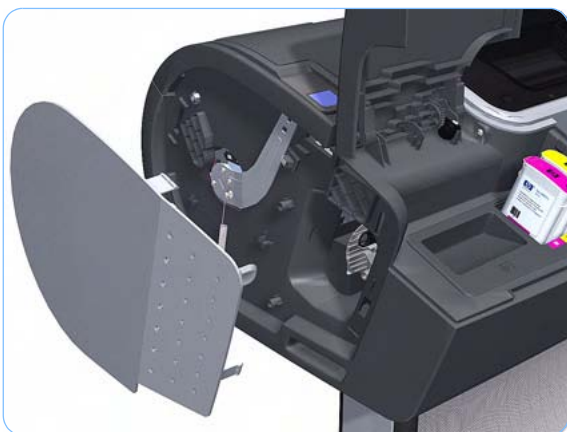

5. Remove the Left Cover Finishing Panel.

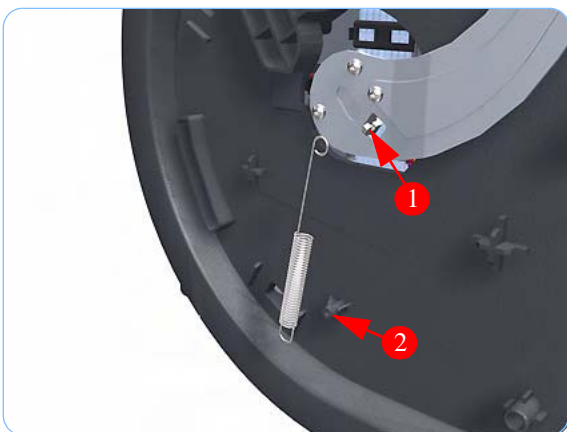

6. Unclip the spring from the attachment points on the Media Lever and Left Cover.

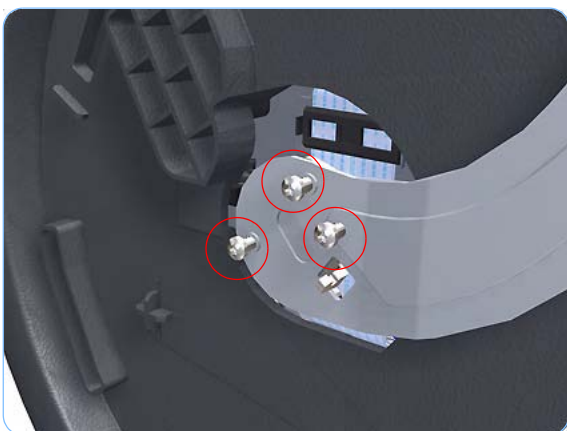

7. Remove three T-15 screws that secure the Media Lever.



- 8.** Remove the Ink Cartridges from the Printer. The illustration shows the Z2100 which has only two Ink Cartridges, for the Z3100 there are six Ink Cartridges.

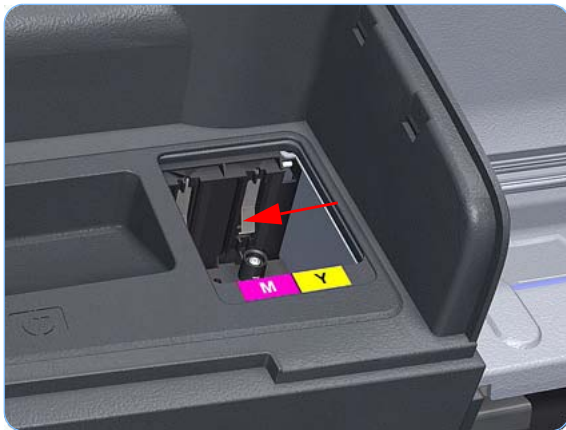

- 9.** For the Z2100, carefully push the edge of the Ink Cartridge Blanking Plate to the left. For the Z3100, continue from step 13 of this procedure.



- 10.** Carefully push the edge of the Ink Cartridge Blanking Plate to the left.



11. Lift the right edge of the Ink Cartridge Blanking Plate.

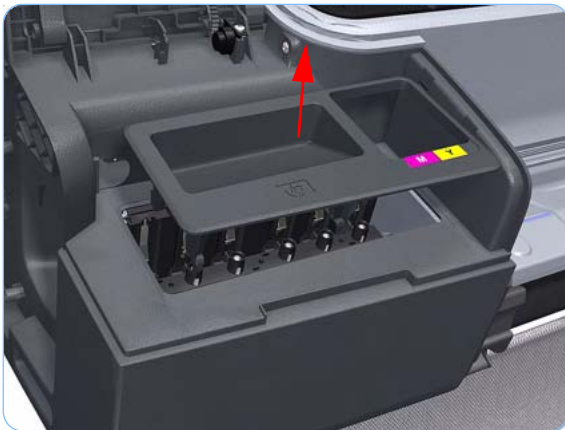

12. Remove the Ink Cartridge Blanking Plate from the Printer.



13. Use a flat bladed screwdriver to unclip the two attachment clips of the Formatter Housing.

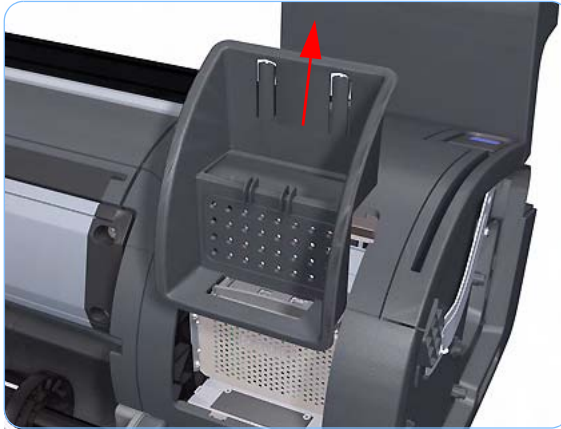

14. Lift the Formatter Housing out of the printer.



15. Remove one T-15 screw that secures the Left Cover (top rear, accessible under the Formatter Housing).



16. Remove one T-15 screw that secures the Left Cover (bottom rear).



17. Remove one T-15 screw that secures the Left Cover (bottom rear).

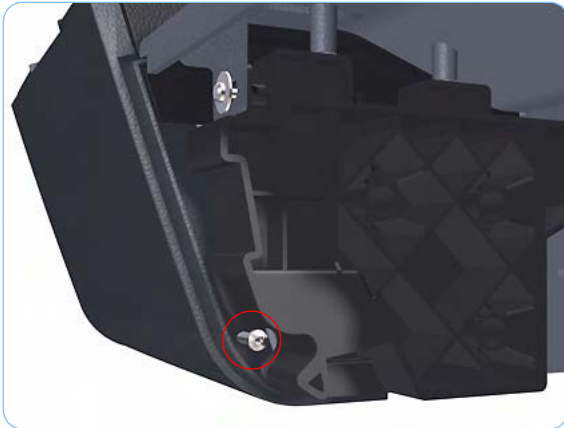

18. Remove one T-15 screw that secures the Left Cover (bottom front, accessible under Front Cover).



19. Remove one T-15 screw that secures the Left Cover (top front, accessible Ink Cartridge Door).



20. Unclip the left Trim.



21. Remove the Left Cover from the Printer.

Rear Tray

Removal

Switch off the printer and remove the power cable.

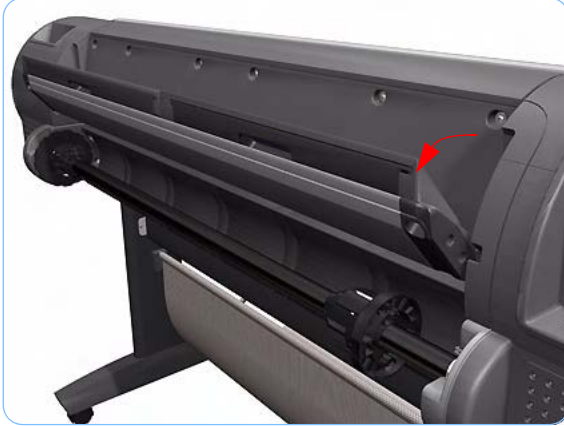

1. Open the Rear Tray to approximately 10 degrees less than the fully open position.



2. Lift the Rear Tray vertically enough (approximately 20 mm) to allow the rear attachment lugs to be out of the locked position.



3. Carefully slide the Rear Tray out of the printer.

Rear Cover

Removal

Switch off the printer and remove the power cable.

1. Remove the Rear Tray (refer to page 8-28).
2. Remove the Right Cover (refer to page 8-18).
3. Remove the Left Cover (refer to page 8-21).
4. Remove ten T-15 screws that secure the Rear Cover to the printer.



5. Remove the Rear Cover from the printer.

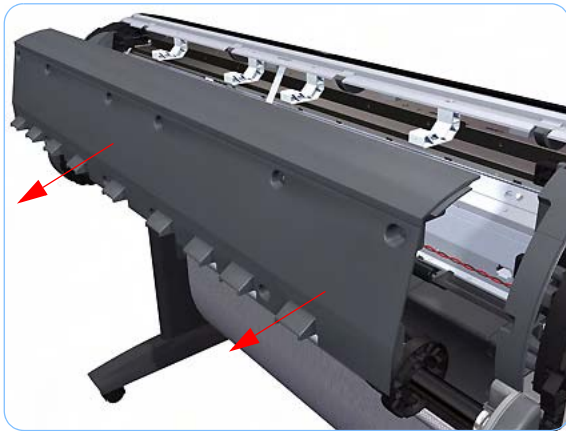

Media Lever

Removal

Switch off the printer and remove the power cable.

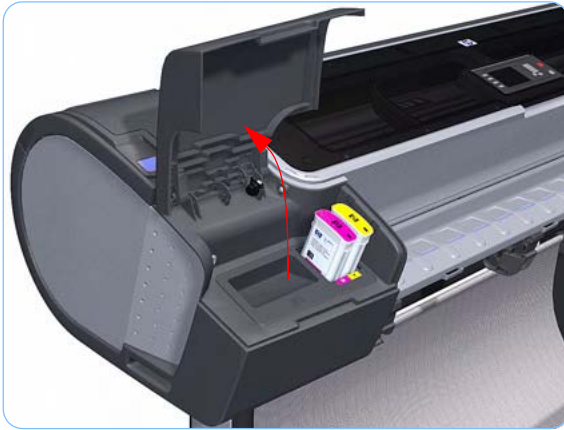

1. Open the Ink Cartridge Door.



2. Press the clip to release the Left Cover Finishing Panel.

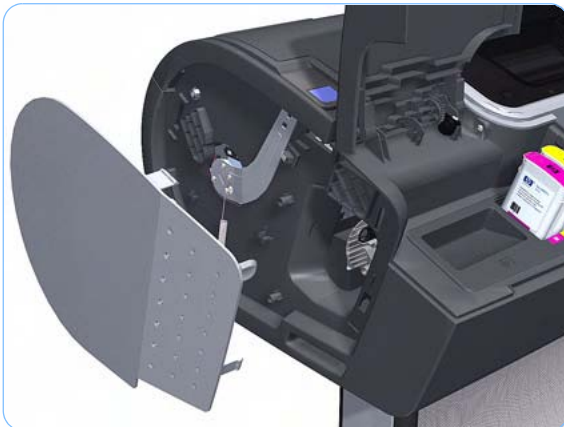

3. Remove the Left Cover Finishing Panel.

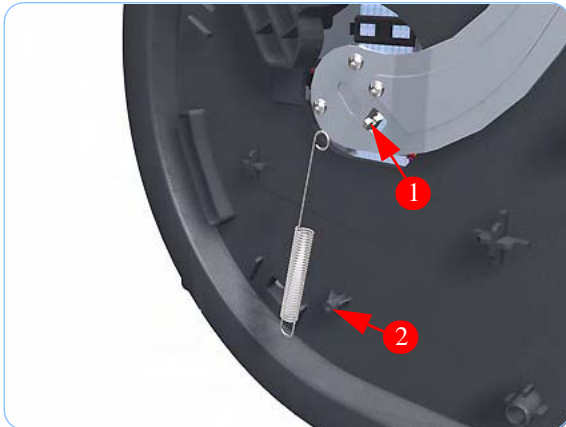

- 4.** Unclip the spring from the attachment points on the Media Lever and Left Cover.

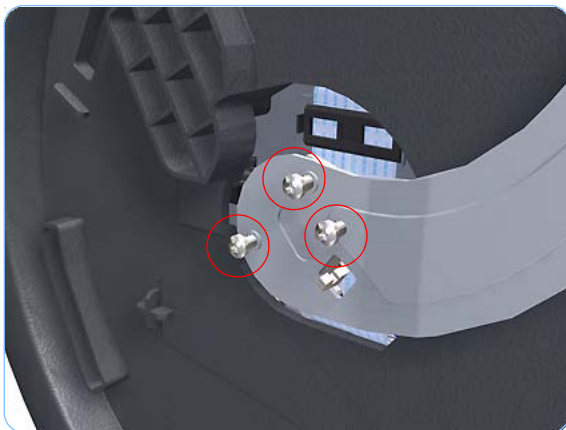

- 5.** Remove three T-15 screws that secure the Media Lever.

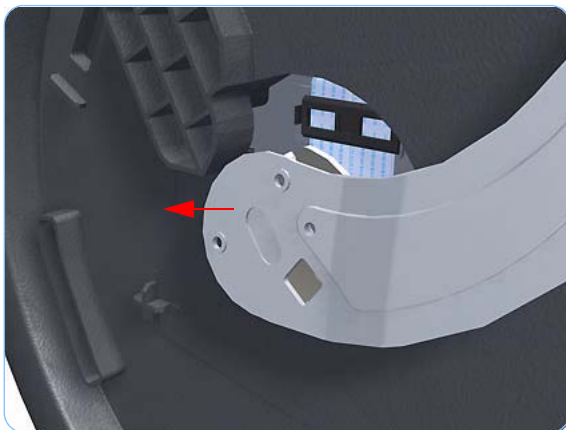

- 6.** Lift the Media Lever of the mounting.

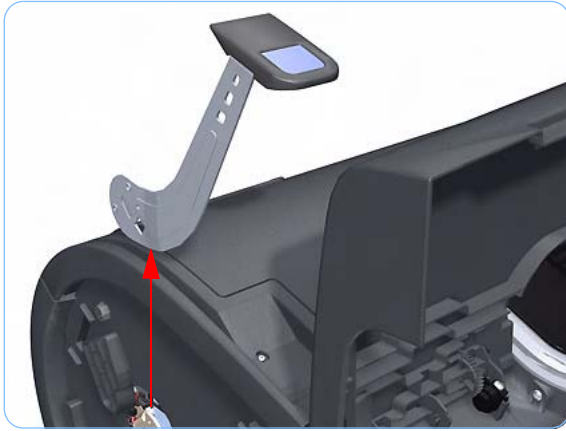

7. Remove the Media Lever from the printer.

Media Lever Position Sensor

Removal

Switch off the printer and remove the power cable.

1. Raise the Media Lever.
2. Remove the Left Cover (refer to page 8-21).
3. Disconnect the Media Lever Position Sensor.

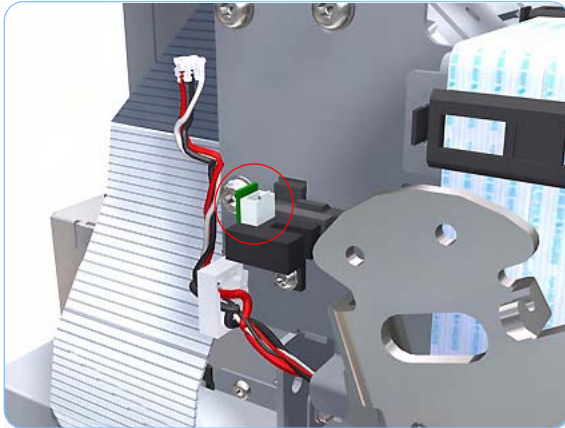

4. Remove one T-15 screw that secures the Media Lever Position Sensor to the Scan Side Panel.

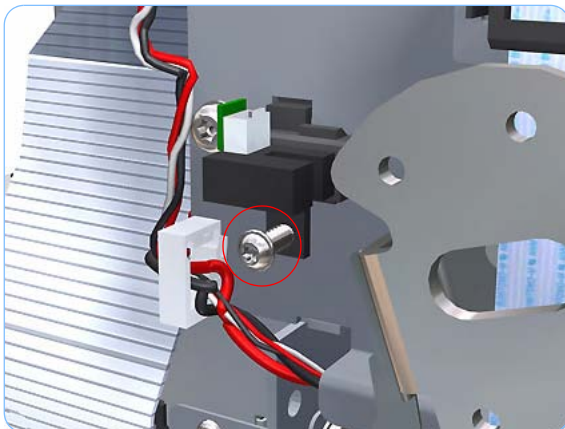

5. Rotate the Media Lever Position Sensor vertically to disengage the attachment lug from the Scan Side Panel.

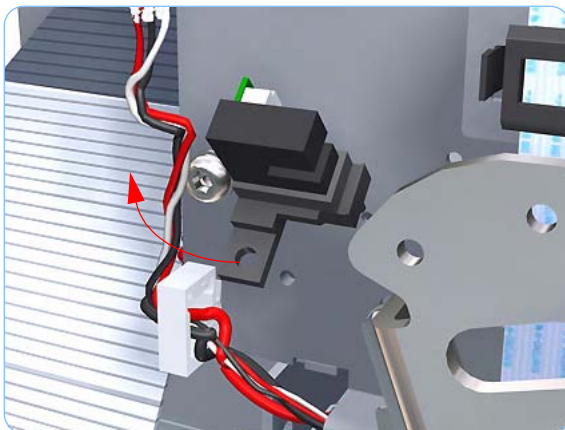

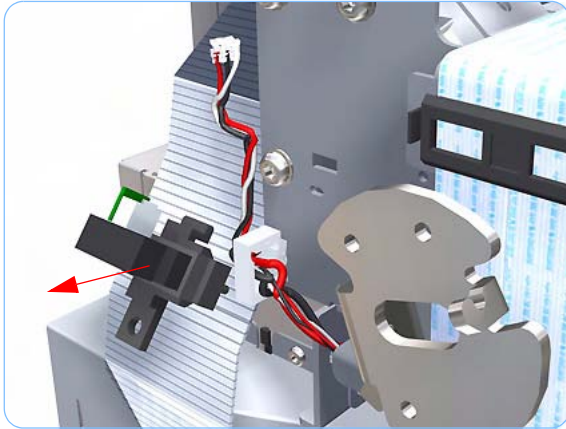

6. Remove the Media Lever Position Sensor.

Cutter Assembly

Removal

Switch off the printer and remove the power cable.

1. Remove the Left Cover Finishing Panel (refer to step 4 of the Left Cover removal procedure on page 8-21).
2. Fully loosen the cutter rail end cap attachment screw.



3. Remove the cutter rail end cap.

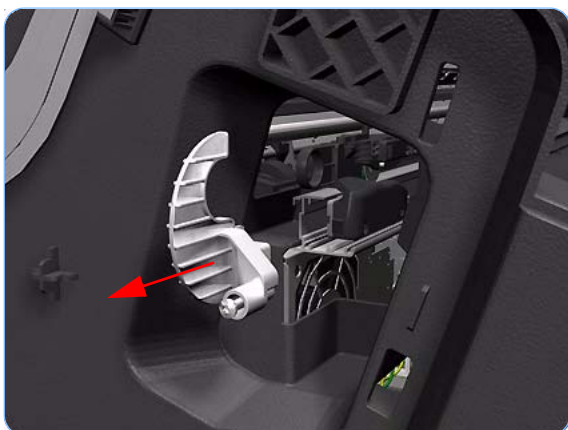

Slide the Cutter Assembly out of the printer.

When you install the new Cutter Assembly, follow the installation instructions provided with the new Cutter Assembly



Right Rear Tray Support

Removal

Switch off the printer and remove the power cable.

1. Remove the Rear Tray (refer to page 8-28).
2. Remove the Right Cover (refer to page 8-18).
3. Remove the Left Cover (refer to page 8-21).
4. Remove the Rear Cover (refer to page 8-29).
5. Remove two T-15 screws that secure the Right Rear Tray Support to the printer.

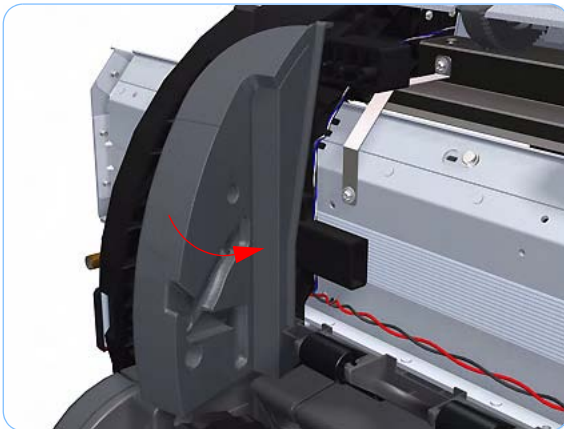
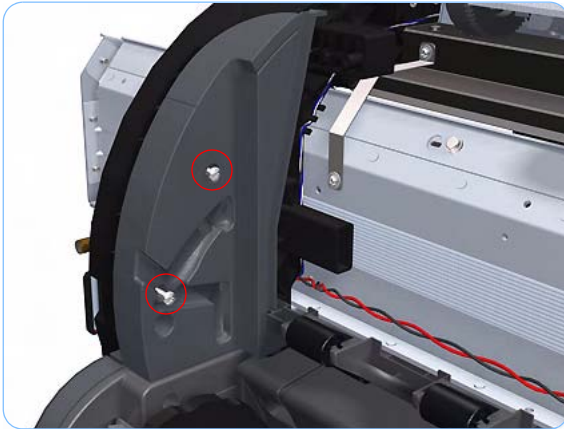

6. Rotate the Right Rear Tray Support counterclockwise approximately 30 degrees.

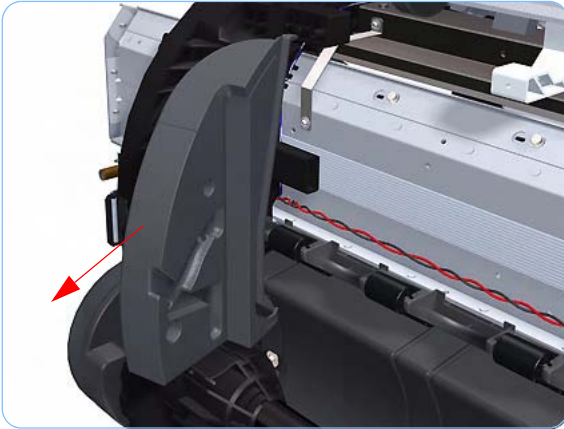

7. Remove the Right Rear Tray Support from the printer.

Left Rear Tray Support

Removal

Switch off the printer and remove the power cable.

1. Remove the Rear Tray (refer to page 8-28).
2. Remove the Right Cover (refer to page 8-18).
3. Remove the Left Cover (refer to page 8-21).
4. Remove the Rear Cover (refer to page 8-29).
5. Remove two T-15 screws that secure the Left Rear Tray Support to the printer.

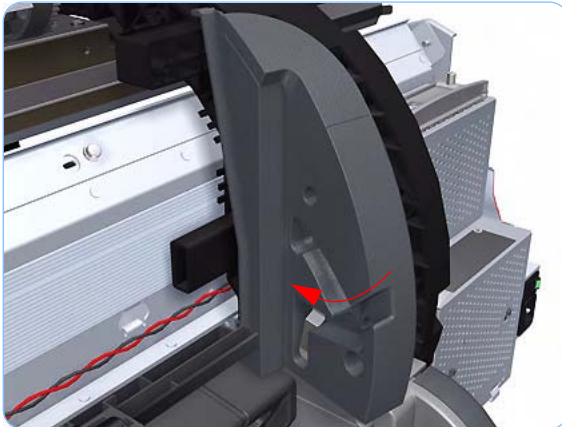
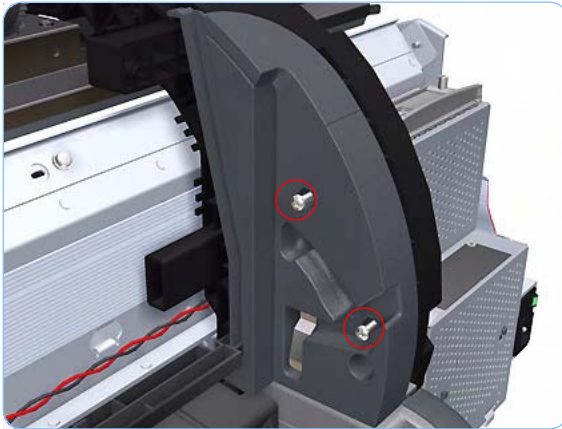

6. Rotate the Left Rear Tray Support clockwise approximately 30 degrees.

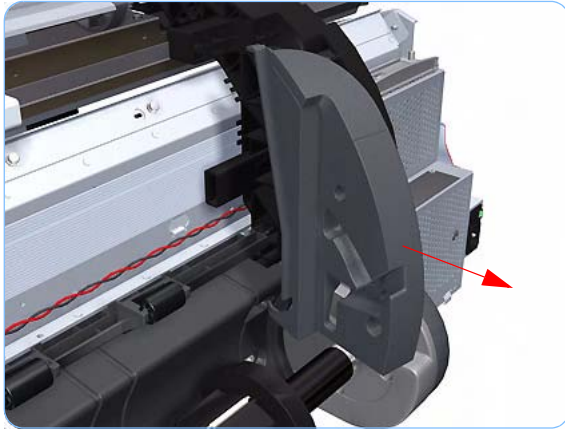

7. Remove the Left Rear Tray Support from the printer.

Front Panel

Removal

Switch off the printer and remove the power cable.



1. Open the Window.



2. Squeeze the top edge of the front panel enough to release the attachment clips.



3. Rotate the front panel vertically.

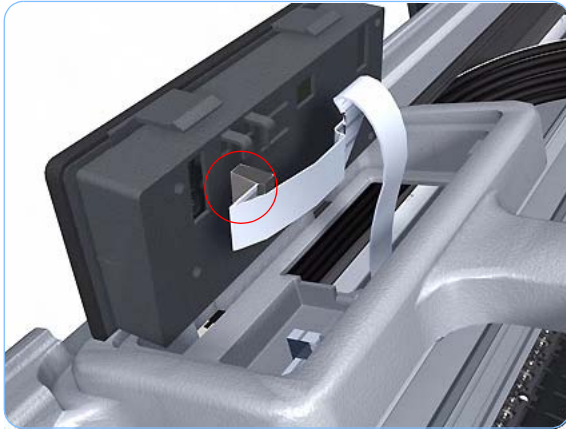

4. Disconnect the interface cable from the Front Panel.

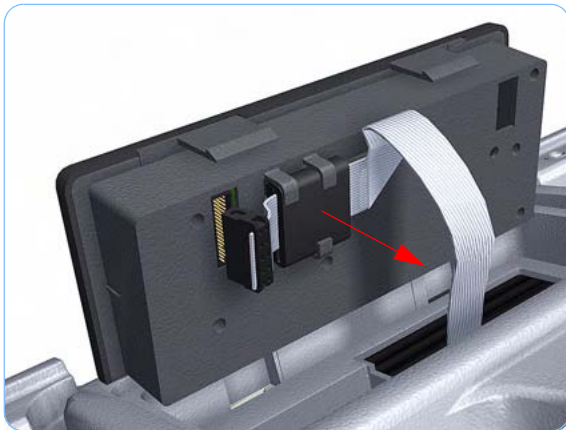

5. Unclip the Ferrite Core from the Front Panel.



6. Remove the Front Panel.

When you reinstall the Front Panel, you must make sure that the Ferrite Core is install and correctly positioned. The Ferrite Core is necessary to avoid electrostatic interference being generated.

Top Cover

Removal

Switch off the printer and remove the power cable.

1. Remove the Window (refer to page 8-4).
2. Remove the Right Cover (refer to page 8-18).
3. Remove the Left Cover (refer to page 8-21).
4. Remove the Rear Tray (refer to page 8-28).
5. Remove the Rear Cover (refer to page 8-29).
6. Remove the Front Panel (refer to page 8-40).
7. Remove the four T-15 top screws that secure the Top Cover to the printer.

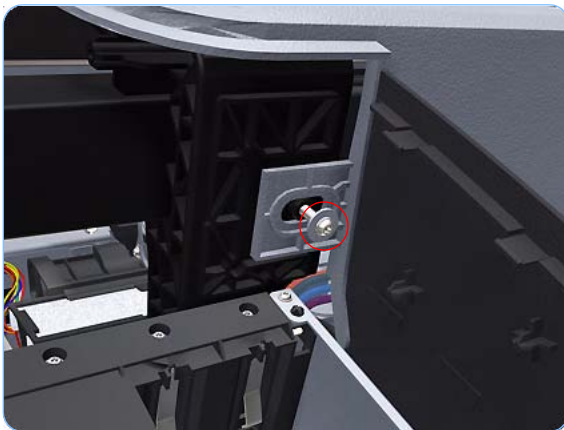

8. Remove the front T-15 screw that secures the front left side of the Top Cover to the printer.

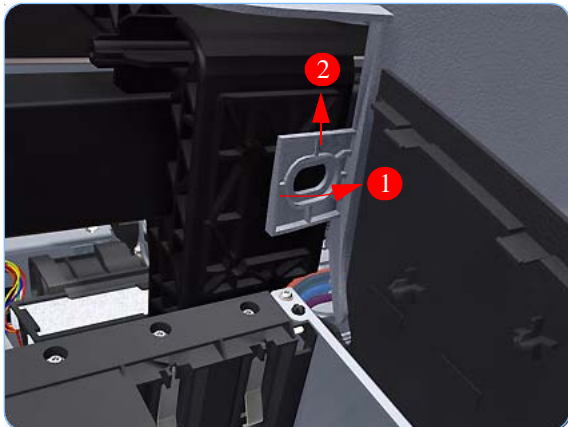

- 9.** Carefully pull the attachment clip forward until you can lift the bottom left corner of the Top Cover approximately 10 mm.

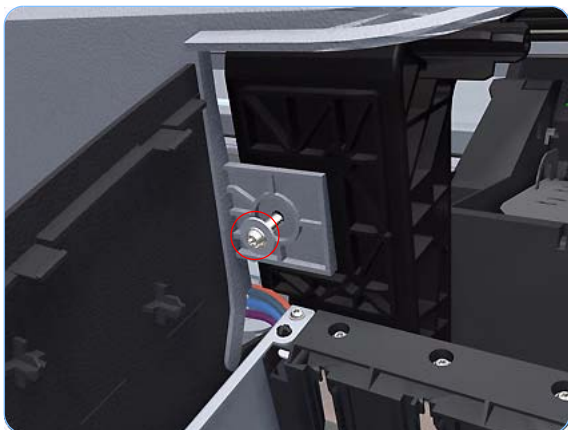

- 10.** Remove the front T-15 screw that secures the front left side of the Top Cover to the printer.

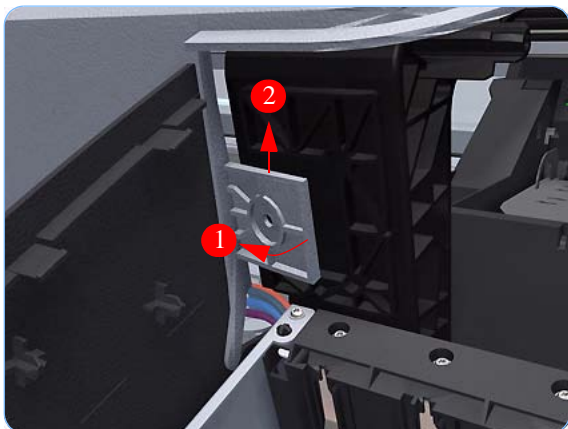

- 11.** Carefully pull the attachment clip forward until you can lift the bottom left corner of the Top Cover approximately 10 mm.

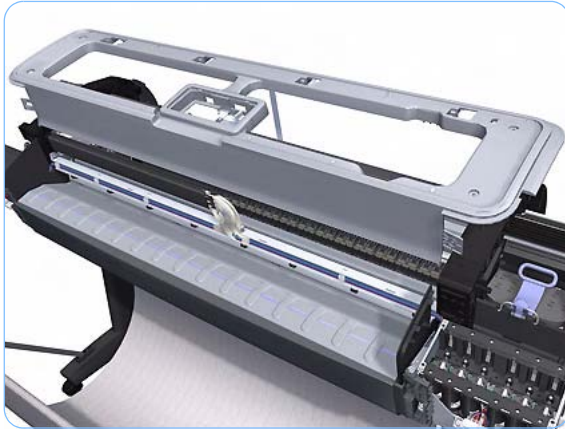

12. Lift the Top Cover of the printer sufficiently to gain access to the Front Panel ribbon cable.

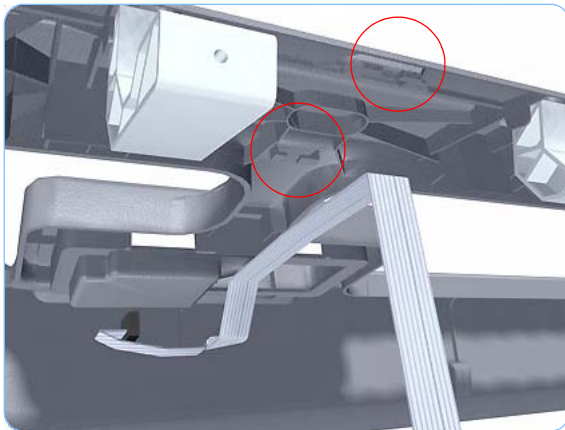

13. Unroute the Front Panel ribbon cable from the two cable clamps on the bottom surface of the Top Cover.

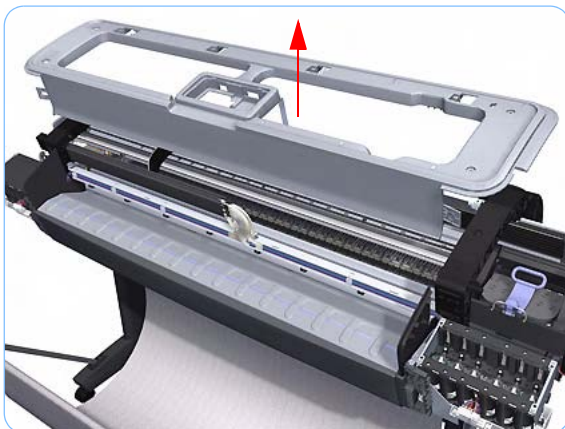

14. Lift the Top Cover off the printer.

Window Position Sensor

Removal

Switch off the printer and remove the power cable.

1. Remove the Right Cover (refer to page 8-18).
2. Remove the Left Cover (refer to page 8-21).
3. Remove the Front Panel (refer to page 8-40).
4. Remove the Top Cover (refer to page 8-42).
5. Disconnect the Window Position Sensor.

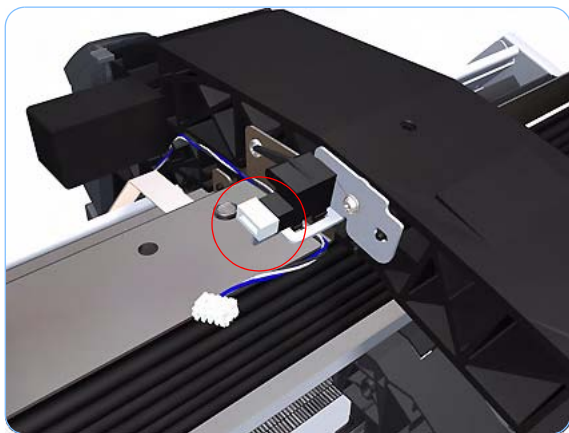

6. Remove one T-15 screw that secures the Window Position Sensor to the printer.

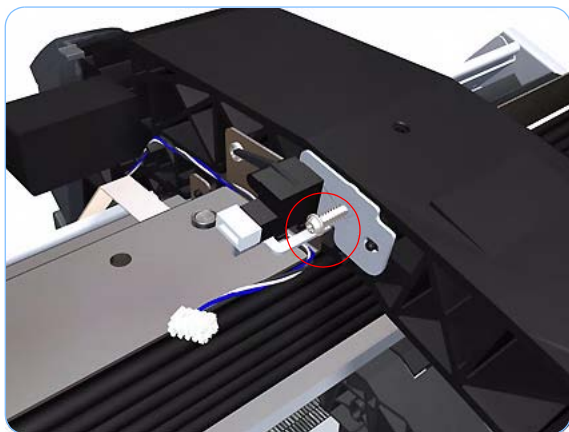

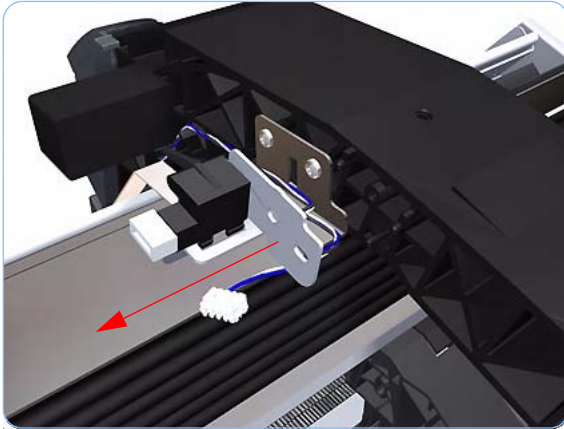

7. Remove the Window Position Sensor to the printer.

Ink Supply Tubes Support Rail

Removal

Switch off the printer and remove the power cable.

1. Remove the Right Cover (refer to page 8-18).
2. Remove the Left Cover (refer to page 8-21).
3. Remove the Front Panel (refer to page 8-40).
4. Remove the Top Cover (refer to page 8-42).
5. Remove the Window Position Sensor (refer to page 8-45).
6. Remove the Ink Supply Tubes from the Ink Supply Tubes Support Rail.

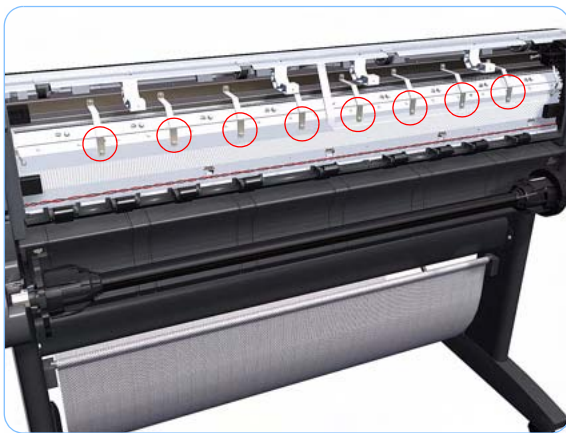

7. Remove the T-15 screws that secure the rear attachment brackets to the Ink Supply Tubes Support Rail.



- 8.** Remove the T-15 screw that attaches the right bonding cable.

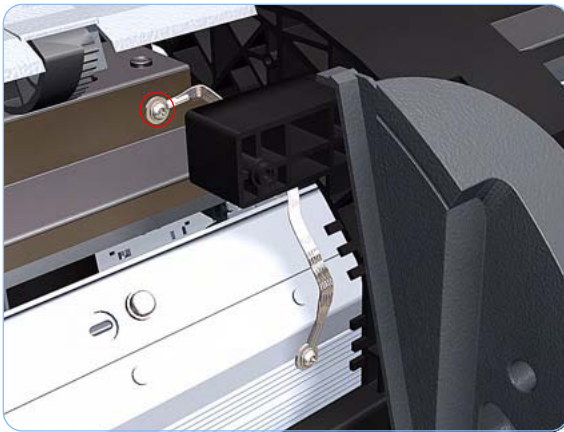

- 9.** Remove the T-15 screw that attaches the left bonding cable.

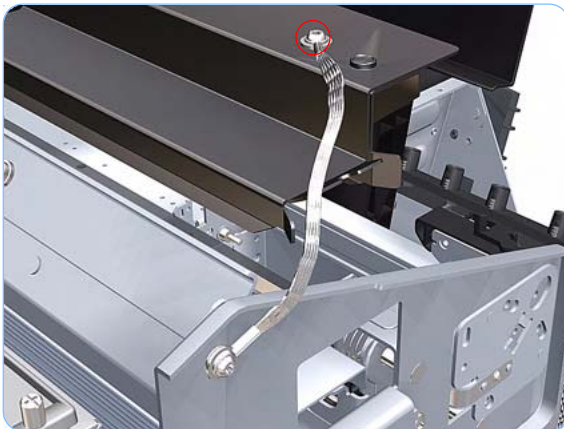

- 10.** Remove the T-15 screw that attaches the left bonding cable.

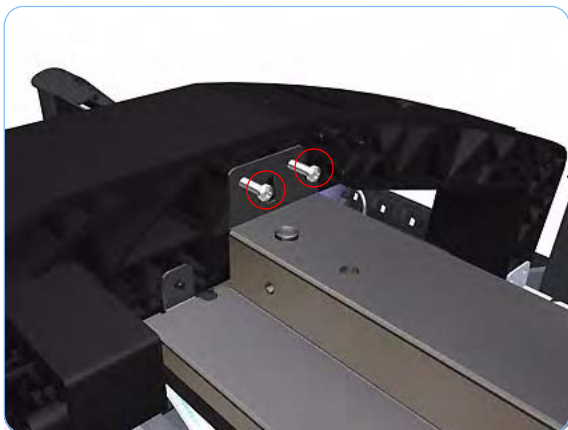

11. Remove two T-15 screws that secure the Ink Supply Tubes Support Rail to the right Top Cover Support.

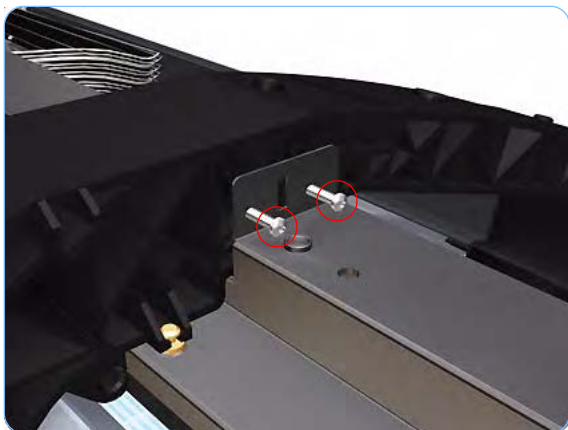

12. Remove two T-15 screws that secure the Ink Supply Tubes Support Rail to the left Top Cover Support.

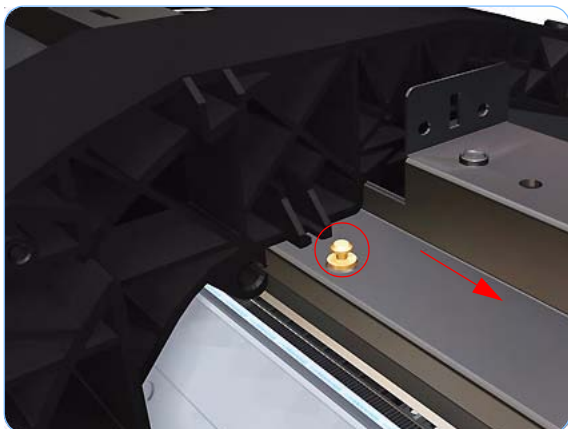

13. Slide the rail to the enough to disengage it from the attachment lug.



- 14.** Carefully slide the Ink Supply Tubes Support Rail to the left until the right end is clear of the right Top Cover Support.



- 15.** Remove the Ink Supply Tubes Support Rail from the printer.

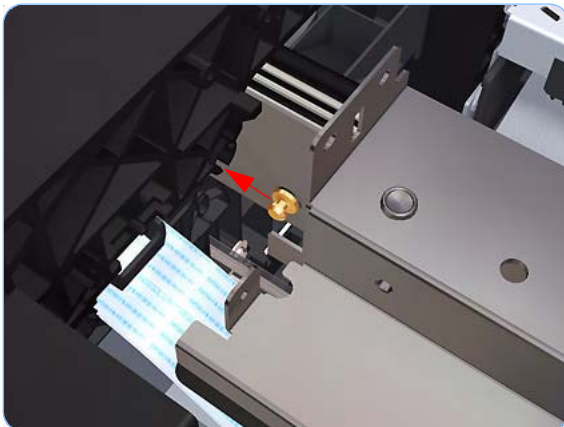

When you reinstall the Ink Supply Tubes Support Rail make sure that the attachment lug is correctly engaged with the right Top Cover Support.

When you reinstall the Ink Supply Tubes Support Rail make sure all the attachment brackets and bonding leads are correctly connected. These are important to avoid electrostatic interference being generated.

Service Station

Removal

Switch off the printer and remove the power cable.

1. Remove the Right Cover (refer to page 8-18).
2. Disconnect the Ink Supply Station ribbon connector and two lower connectors from the PrintMech PCA.

The Ink Supply Station ribbon connector has to be disconnected so the other cables can be unrouted



3. Unroute the two cables disconnected in step 2 from the two cable clamps below the PrintMech PCA.



4. Remove the grounding cable attachment screw from the PrintMech PCA.

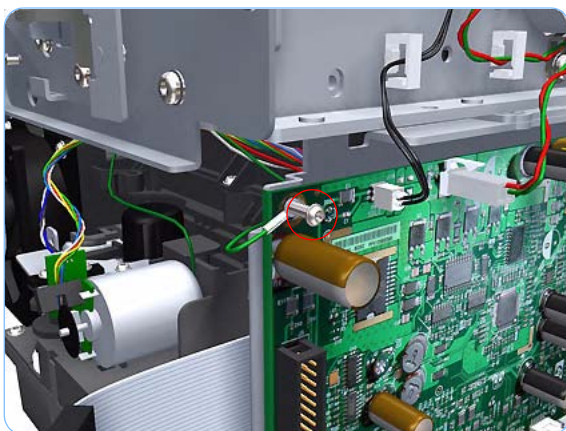

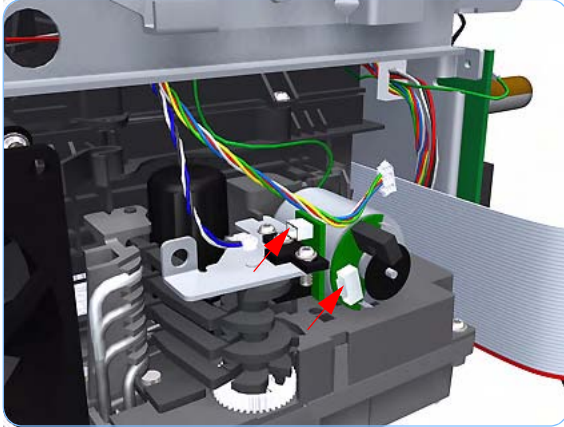

5. Disconnect connector from the Drop Detector Motor and Drop Detector Sensor.

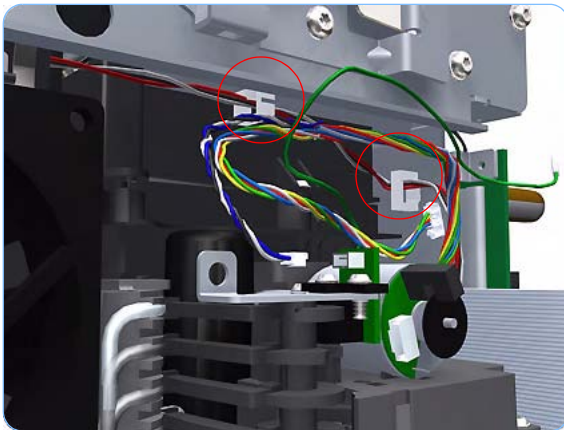

6. Unroute the cables disconnected in steps 4 and 5 from the two cable clamps.

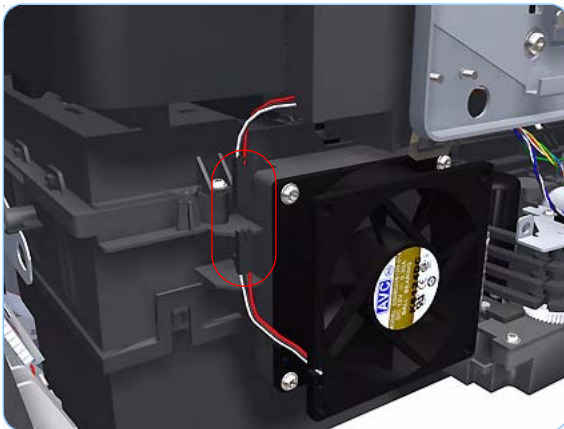

7. Disconnect the Aerosol Fan Assembly inline connector.

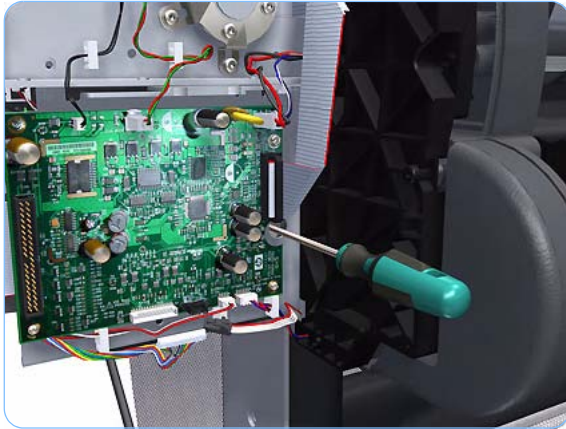

8. Loosen the T-10 uncapping screw sufficiently so you can manually move the Carriage Assembly in step 9.



9. Push the Carriage Assembly into the print path to gain access to two T-15 screws that secure the Service Station to the Carriage Rail.

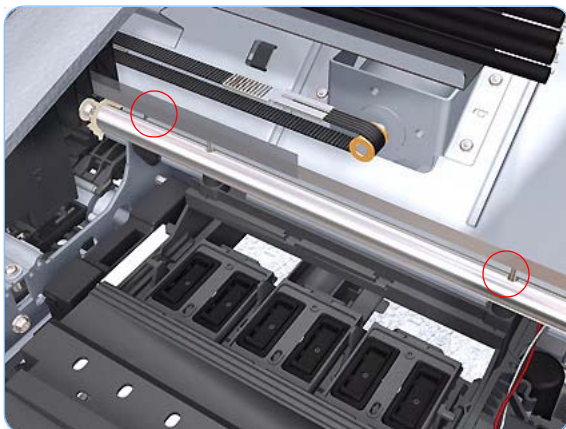

10. Use an allen key provided in the tool kit to remove two allen screws that secure the Service Station to the Carriage Rod.

Support the Service Station so it does not fall when you remove the attachment screws.

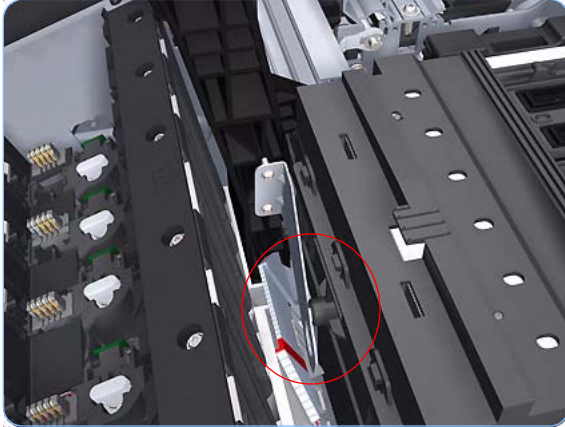

11. Unclip the clip to release the Service Station from the printer.

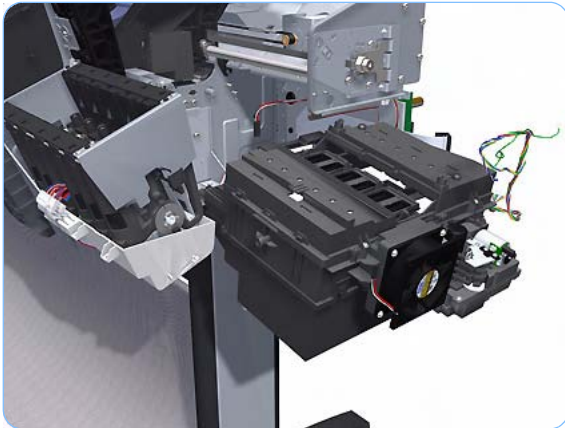

12. Lower the right of the Service Station enough to allow you to slide it carefully out of the printer.

Drop Detector

Removal

Switch off the printer and remove the power cable.

1. Remove the Right Cover (refer to page 8-18).
2. Remove the Service Station (refer to page 8-51).
3. Unroute the Drop Detector ribbon cable from the Service Station cable clamps.

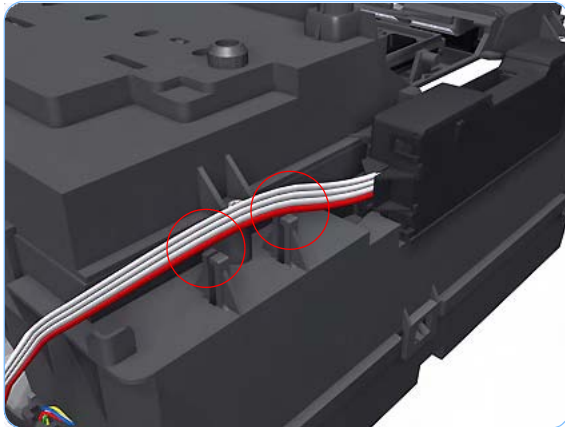

4. Remove the T-15 screw that secures the Drop Detector to the Service Station.

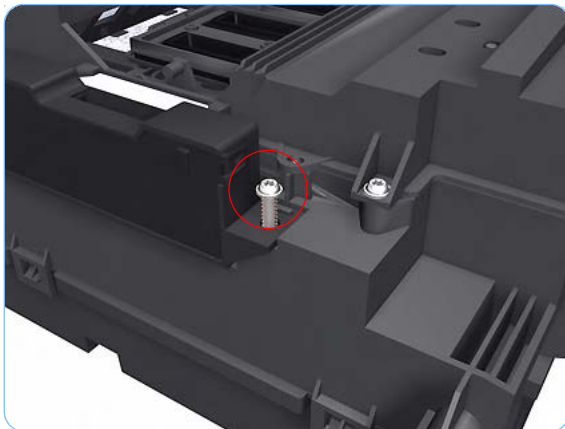

5. Lift the Drop Detector off the Service Station.

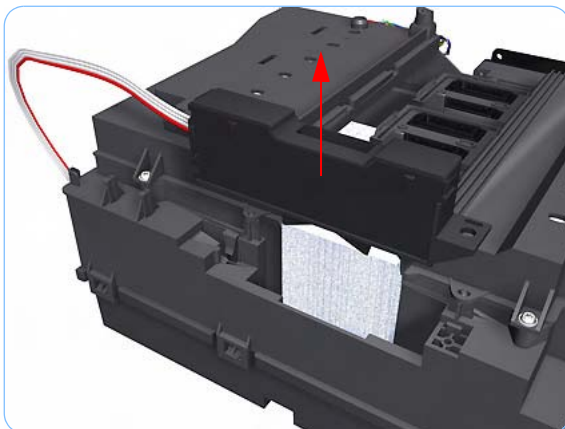

Aerosol Fan Assembly

Removal

Switch off the printer and remove the power cable.

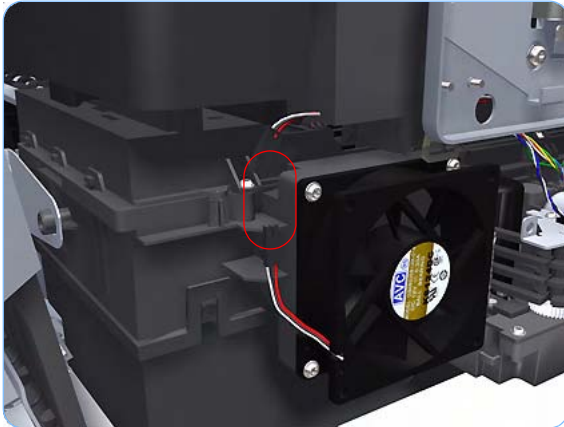

1. Remove the Right Cover (refer to page 8-18).
2. Disconnect the Aerosol Fan Assembly in-line connector.

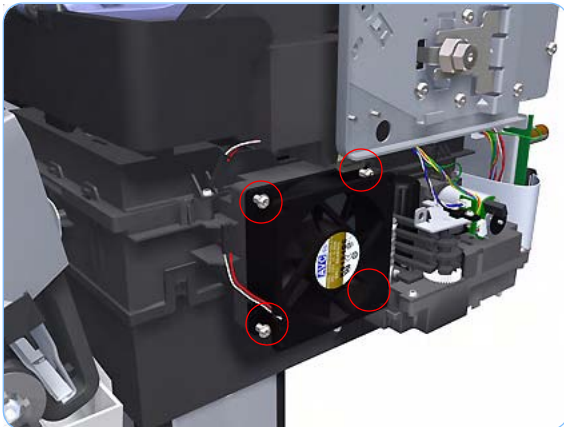

3. Remove the four T-15 screws that secure the Aerosol Fan Assembly to the Service Station.

The four access holes in the Aerosol Fan Assembly housing are the same size as the attachment screw diameter so you will need a normal Torx Screwdriver, not a multi-tool, to remove the screws.

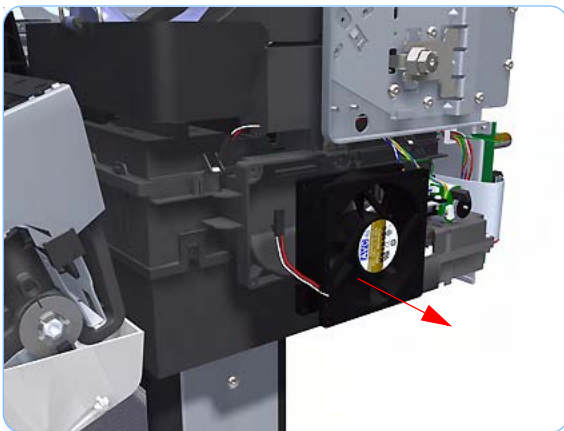

4. Remove the Aerosol Fan Assembly from the Service Station.

When you reinstall the Aerosol Fan Assembly make sure you position it so that the power cable is on the outside exiting to the right.

Primer Assembly

Removal

Switch off the printer and remove the power cable.

1. Remove the Right Cover (refer to page 8-18).
2. Remove the Service Station (refer to page 8-51).
3. Pull out the spitting tube from the Service Station Spittoon and unroute it from the attachment clip.

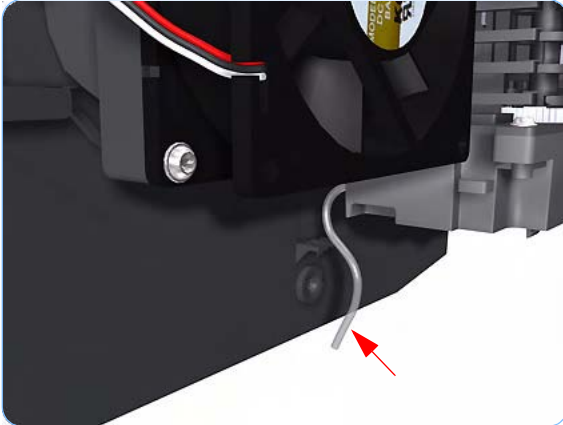

4. Unroute the cable assembly from attachment clip on the Service Station Spittoon.

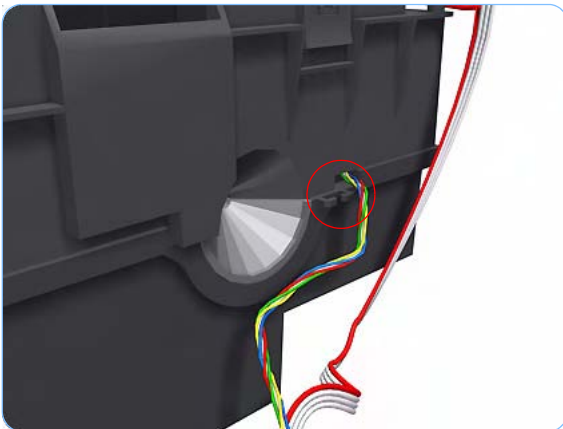

5. Unclip the front left clip that secures the Service Station to the Service Station Spittoon.

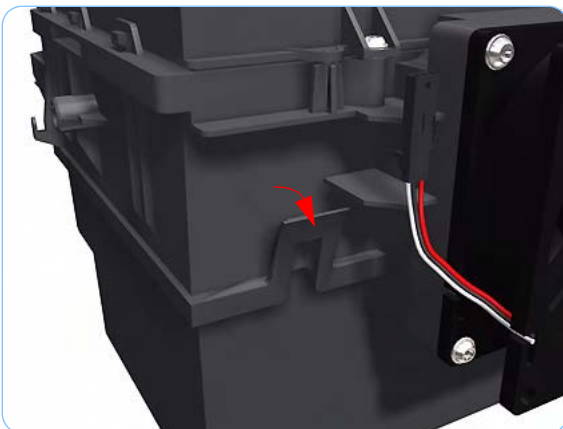

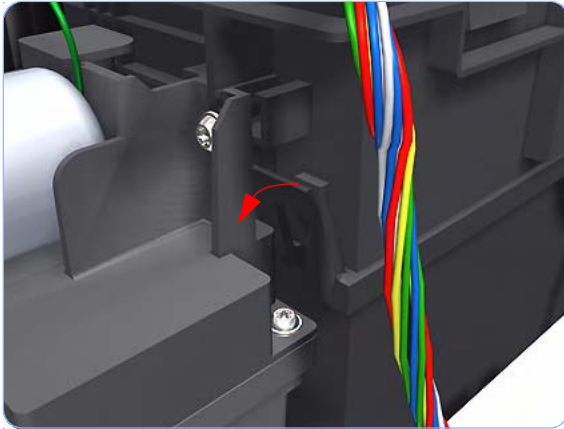

6. Unclip the front left clip that secures the Service Station to the Service Station Spittoon.

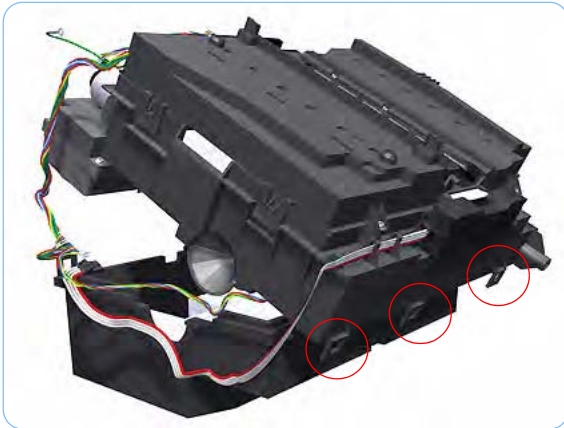

7. Carefully raise the Service Station vertically from the clip side (by approximately 30 degrees) until you can disengage it from the three attachments on the opposite side to remove it from the Left Spittoon.

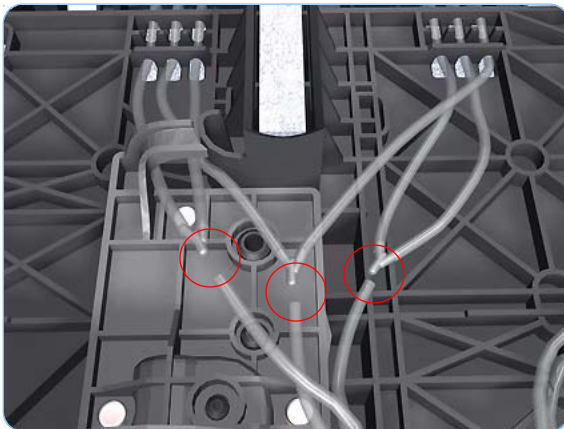

8. Disconnect the three Primer Assembly tubes.

It is recommended that you use protective gloves when handling the Primer Assembly

Use a suitable method to identify each Primer Assembly tube for correct re-connection during assembly components.

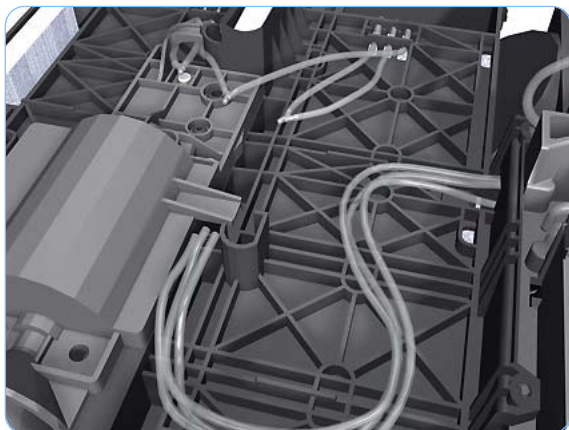

9. Unroute the three Primer Assembly tubes.

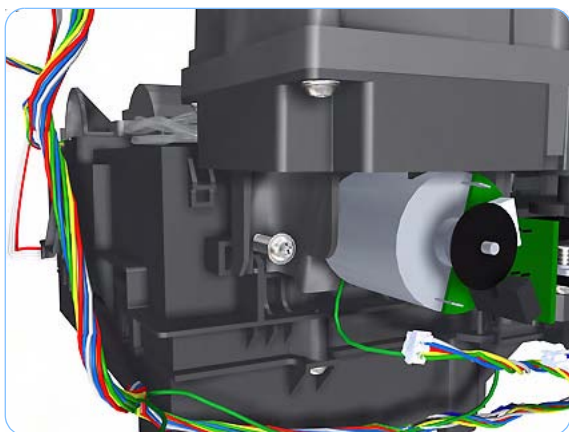

10. Remove the T-15 screw that secures the Primer Assembly to the Service Station.

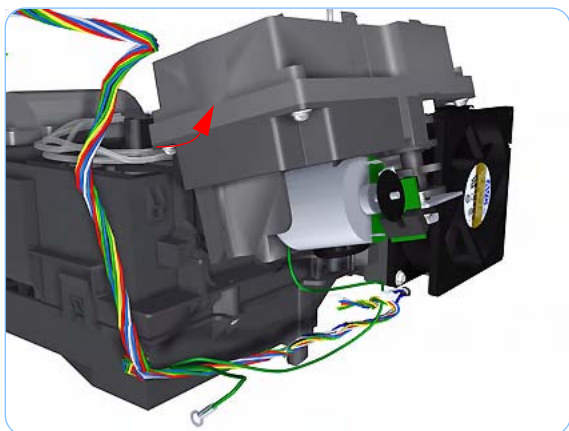

11. Tilt the Primer Assembly to disengage the lower edge.

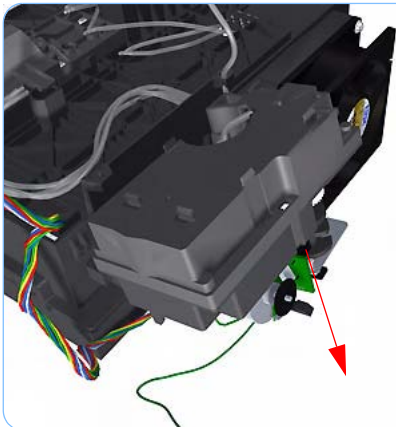

12. Lower the Primer Assembly to disengage the top attachment lugs.

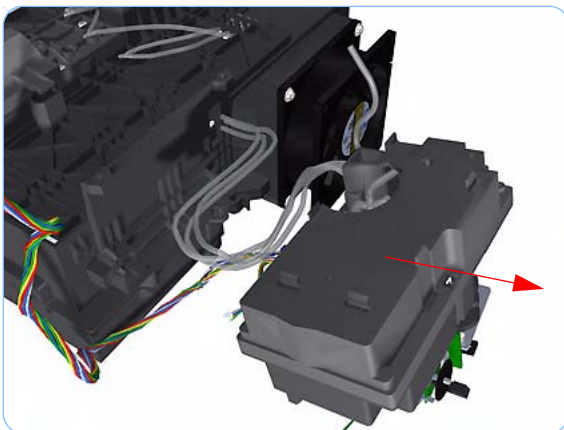

13. Remove the Primer Assembly from the Service Station.

When you install the Primer Assembly make sure you connect the three primer tubes in accordance with their identification markings.

PrintMech PCA

Removal

Switch off the printer and remove the power cable.

1. Remove the Right Cover (refer to page 8-18).
2. Disconnect all the electrical connectors from the PrintMech PCA.

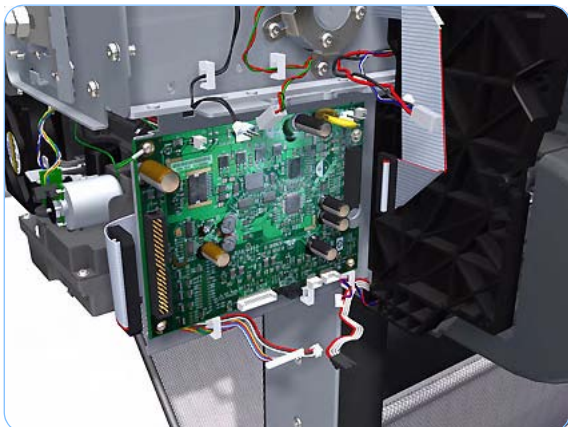

3. Remove the grounding cable attachment screw from the PrintMech PCA.

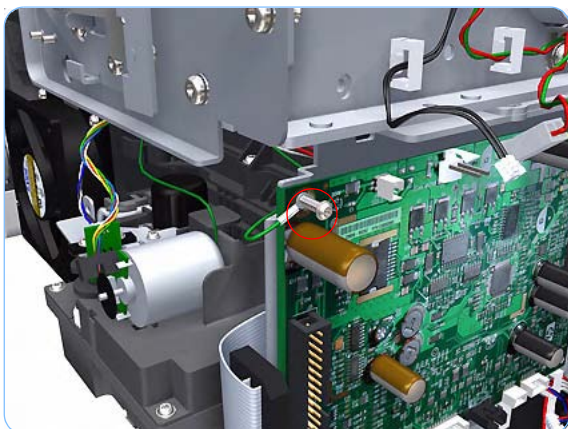

4. Remove the three T-15 screws that secure the PrintMech PCA to the Service Station.

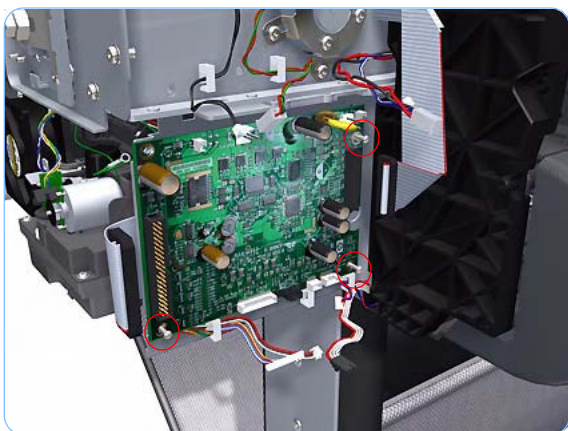

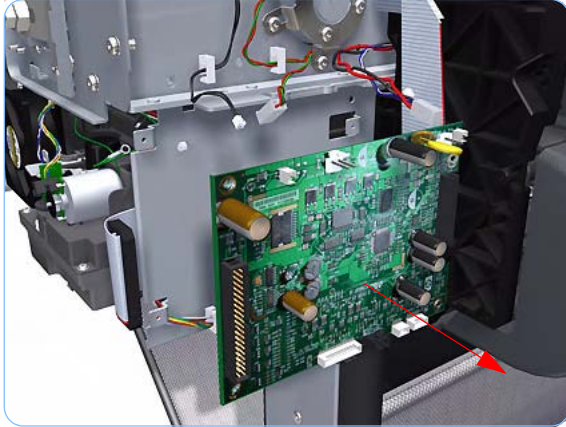

5. Remove the PrintMech PCA from the printer.

Pen to Paper Space (PPS) Solenoid

Removal

Switch off the printer and remove the power cable.

1. Remove the Right Cover (refer to page 8-18).
2. Unroute the Pen to Paper Space (PPS) Solenoid cable from the cable clamp.

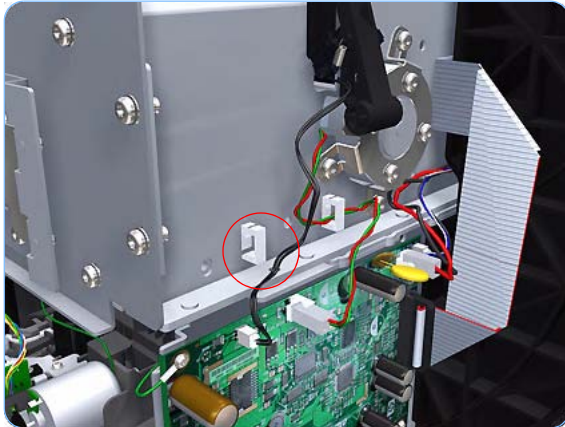

3. Disconnect the Pen to Paper Space (PPS) Solenoid connector from the PrintMech PCA.



4. Remove two T-15 screws that secure the Pen to Paper Space (PPS) Solenoid to the printer.



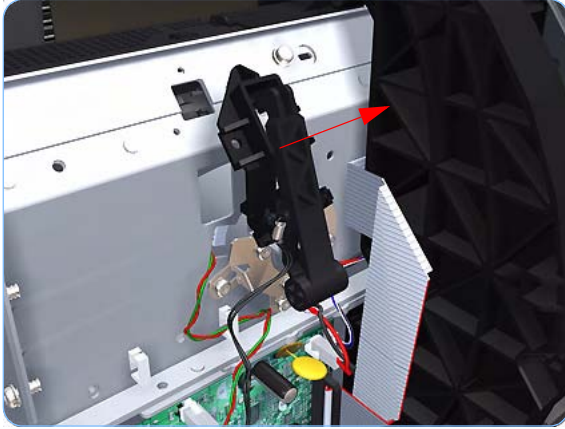

5. Remove the Pen to Paper Space (PPS) Solenoid from the printer.

Spindle

Removal

Switch off the printer and remove the power cable.



1. Pull the left end of the Spindle (viewed from the front of the printer) out of the Left Spindle Holder.



2. Lift the Spindle out of the printer towards the left (viewed from the front of the printer).

Left Spindle Holder

Removal

Switch off the printer and remove the power cable.



1. Remove the Spindle (refer to page 8-65).
2. Remove two T-15 screws that secure the Left Spindle Holder to the printer.



3. Rotate the Left Spindle Holder towards the left.



4. Remove the Left Spindle Holder from the printer.

Right Spindle Holder

Removal

Switch off the printer and remove the power cable.

1. Remove the Spindle (refer to page 8-65).
2. Remove two T-15 screws that secure the Right Spindle Holder to the printer.



3. Rotate the Right Spindle Holder towards the right.

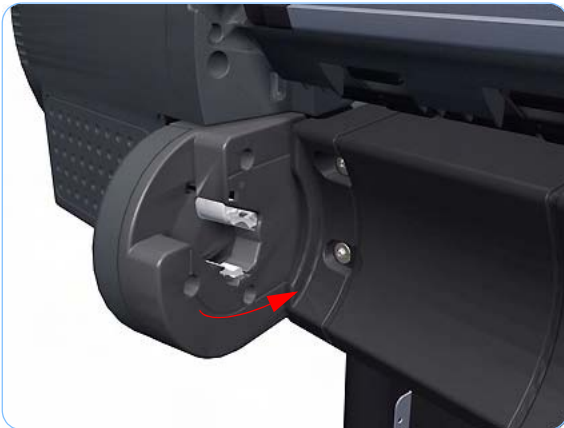

4. Remove the Right Spindle Holder from the printer.

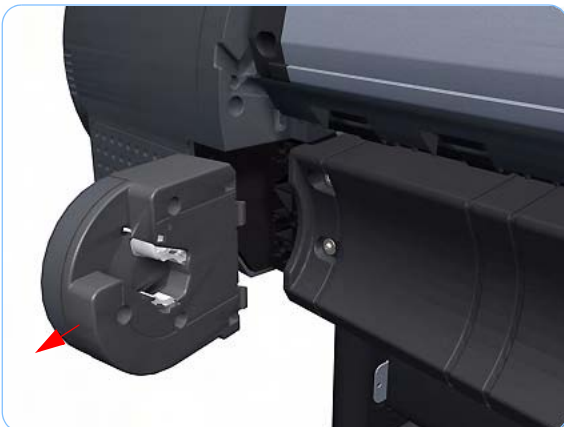

Clean Out Assembly

Removal

Switch off the printer and remove the power cable.

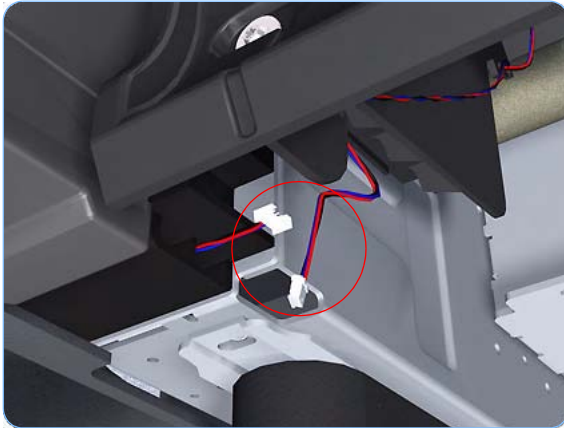

1. Remove the Spindle (refer to page 8-65).
2. Disconnect the Out Of Paper Sensor in-line connector and unrout the its cable.

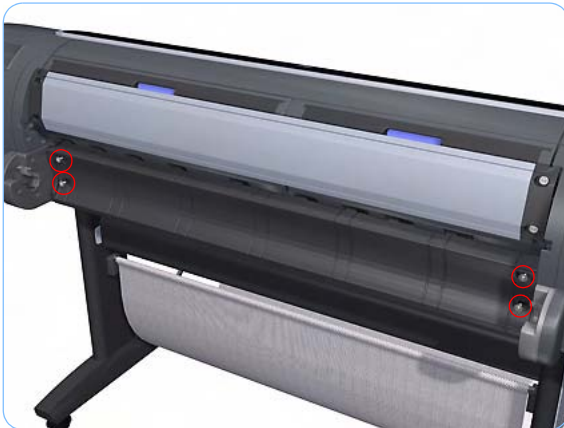

3. Remove the four T-15 screws that secure Clean Out Assembly to the printer.



4. Slide the Clean Out Assembly out of the printer.

Out Of Paper Sensor

Removal

Switch off the printer and remove the power cable.

1. Remove the Spindle (refer to page 8-65).
2. Remove the Clean Out Assembly (refer to page 8-68).
3. Unroute the Out Of Paper Sensor electrical cables from the Clean Out Assembly.

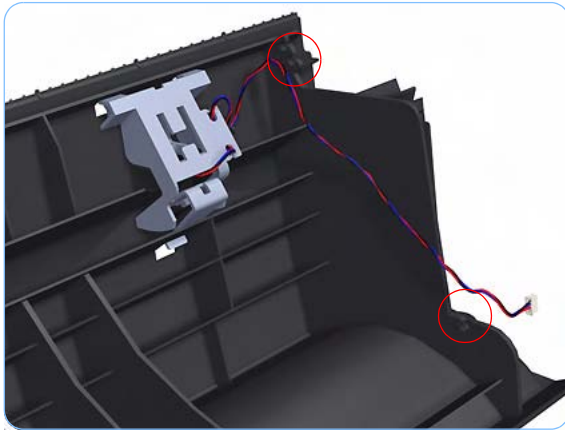

4. Unroute (unwind) the Out Of Paper Sensor electrical cables from the Out Of Paper Sensor cover.

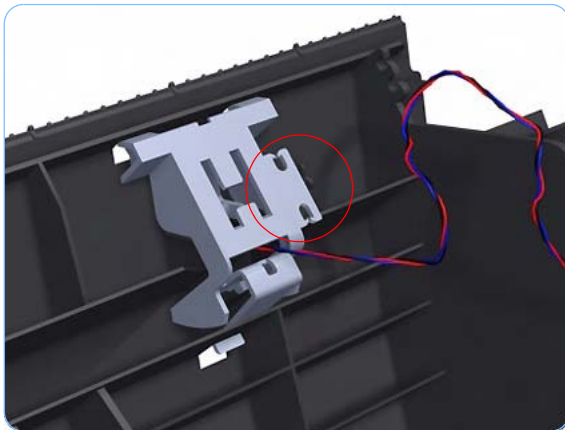

5. Press the clip to remove the Out Of Paper Sensor cover from the Clean Out Assembly.

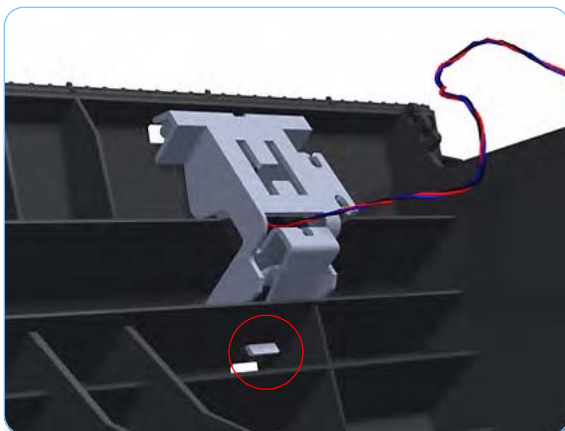

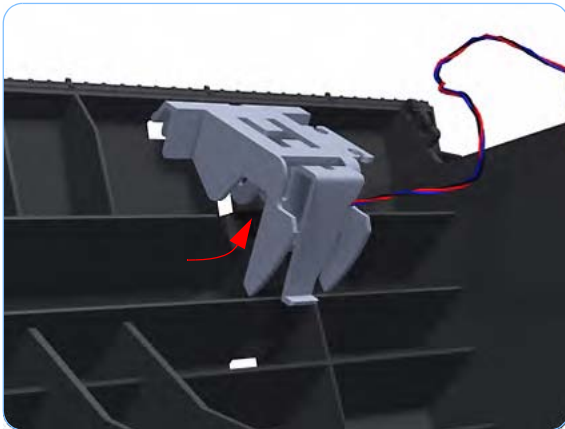

- 6.** Rotate the Out Of Paper Sensor cover approximately 45 degrees.

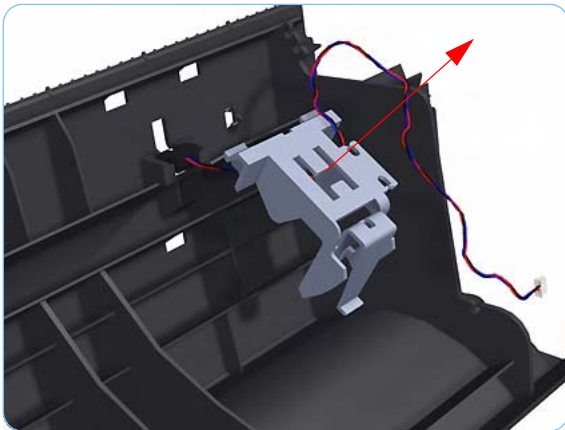

- 7.** Remove the Out Of Paper Sensor cover from the Clean Out Assembly

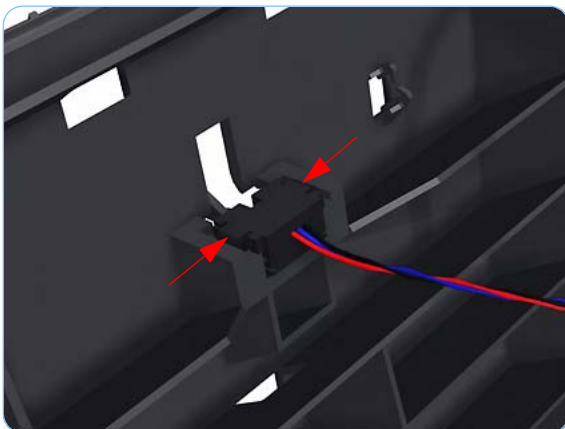

- 8.** Squeeze the Out Of Paper Sensor attachment clips to remove it from the Clean Out Assembly.

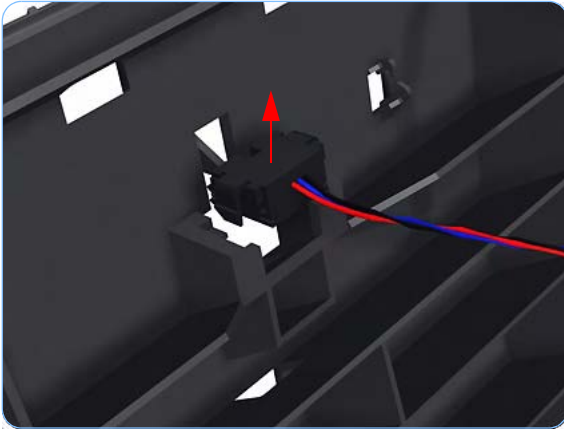

9. Lift the Out Of Paper Sensor out of the Clean Out Assembly.

Left Roll Guide

Removal

Switch off the printer and remove the power cable.

1. Remove the Spindle (refer to page 8-65).
2. Remove the Clean Out Assembly (refer to page 8-68).
3. Remove five T-15 screws that secure Left Roll Guide to the printer.

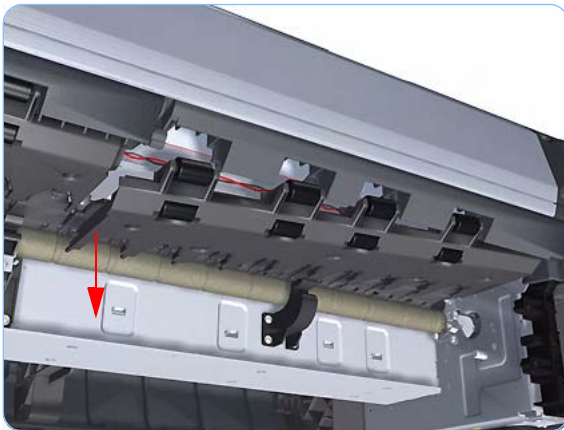
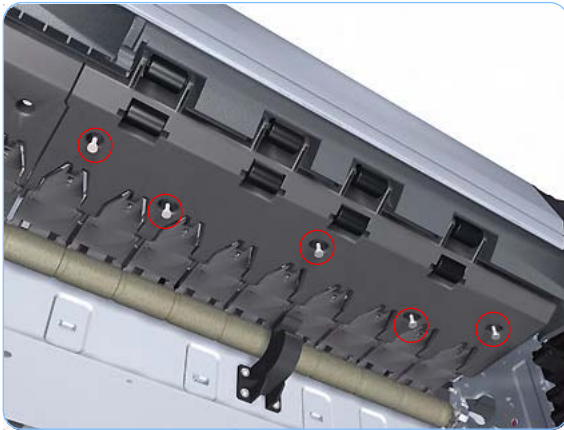

4. Lower the left end and remove the Left Roll Guide from the printer.

Right Roll Guide

Removal

Switch off the printer and remove the power cable.

1. Remove the Spindle (refer to page 8-65).
2. Remove the Clean Out Assembly (refer to page 8-68).
3. Remove the Left Roll Guide (refer to page 8-72).
4. Remove seven T-15 screws that secure Right Roll Guide to the printer.

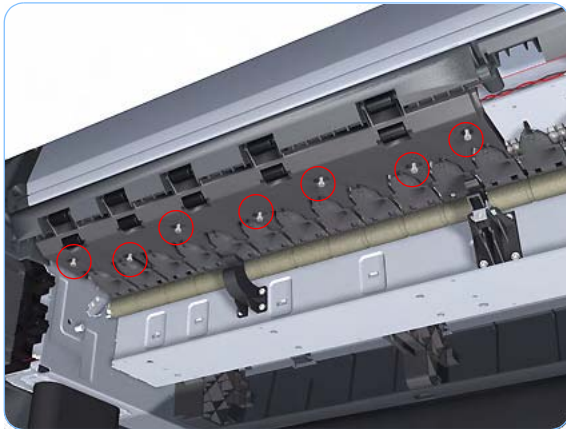

5. Lower the right end and remove the Right Roll Guide from the printer.

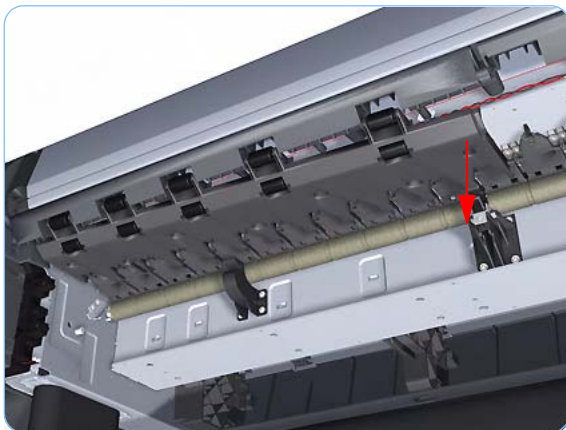

Encoder Strip (with spring and attachment nut)

Removal

Switch off the printer and remove the power cable.

1. Remove the Right Cover (refer to page 8-18).
2. Remove the Left Cover (refer to page 8-21).
3. Remove the T-15 screw that secures Encoder Strip to the printer.

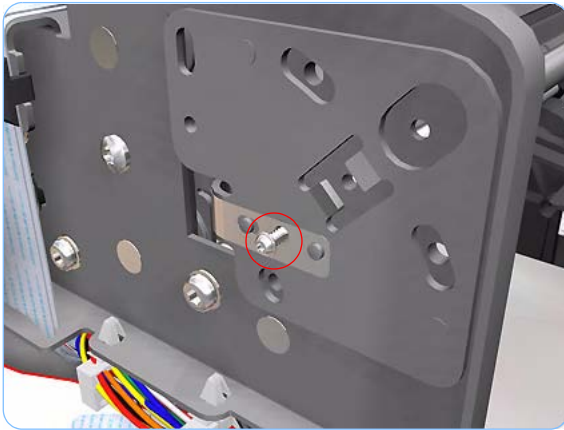

4. Grip the Encoder Strip and move it towards the left to take off the tension until you have completed the next step.

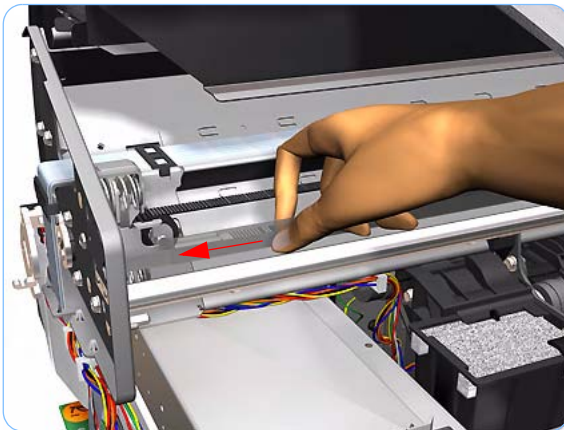

5. Unclip the Encoder Strip from its attachment lugs.

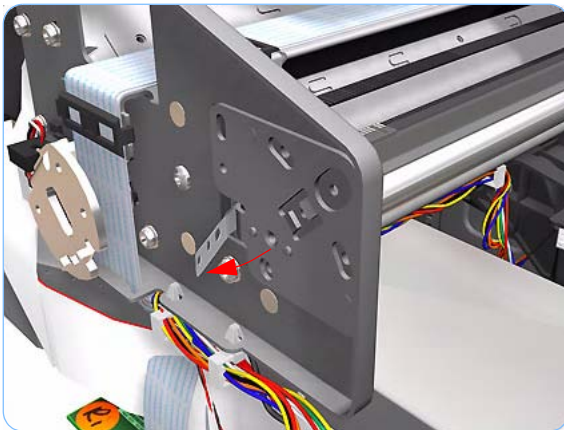

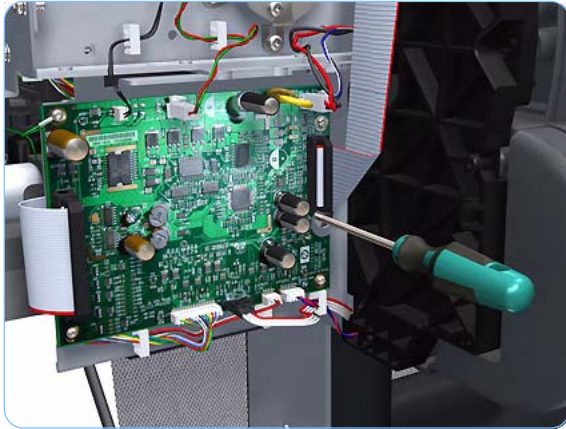

6. Loosen the T-10 uncapping screw sufficiently so you can manually move the Carriage Assembly in step 7.

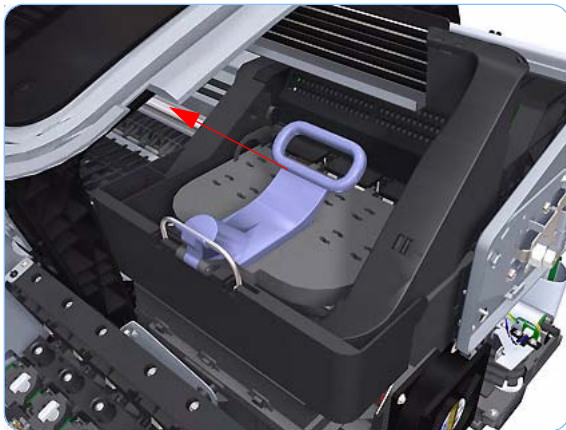

7. Push the Carriage Assembly into the print path.

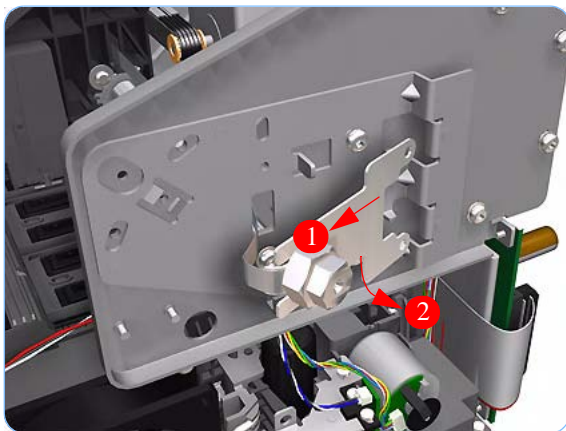

8. Unclip the Encoder Strip tensioner from the right hand end.

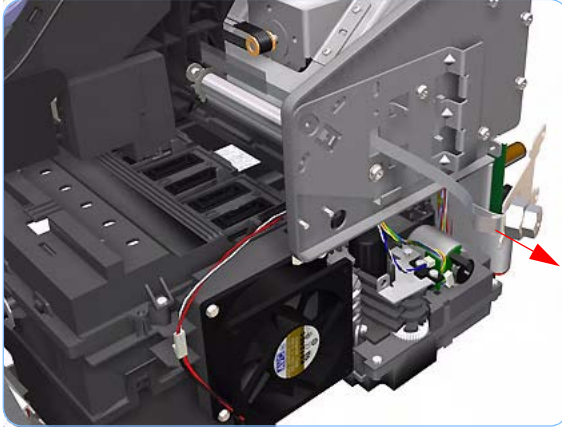

9. Carefully pull the Encoder Strip out of the printer from the right hand end.

Encoder Strip

Removal

Switch off the printer and remove the power cable.

1. Remove the Right Cover (refer to page 8-18).
2. Remove the Left Cover (refer to page 8-21).
3. Remove the Encoder Strip (with spring and attachment nut) (refer to page 8-74).
4. Use the spanner provided in the tool kit to remove the 13 mm locking nut that secures the Encoder Strip to the Encoder Strip Spring.

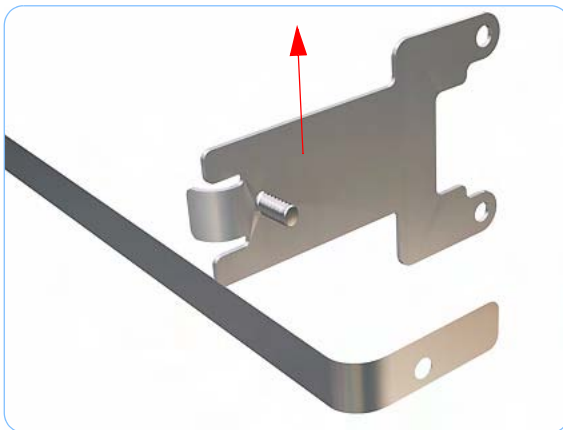
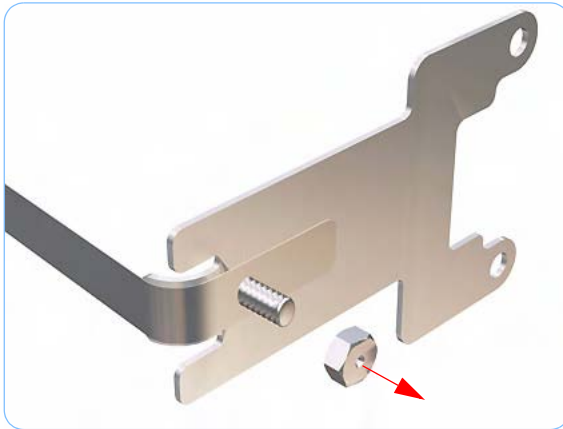

5. Remove the Encoder Strip Spring.

Trailing Cable

Removal

Switch off the printer and remove the power cable.

1. Remove the Left Cover (refer to page 8-21).
2. Remove the Right Cover (refer to page 8-18).
3. Remove the Front Panel (refer to page 8-40).
4. Remove the Top Cover (refer to page 8-42).
5. Remove the Window Position Sensor (refer to page 8-45).
6. Remove the Ink Supply Tubes Support Rail (refer to page 8-47).
7. Loosen the T-10 uncapping screw sufficiently so you can manually move the Carriage Assembly in step 8.

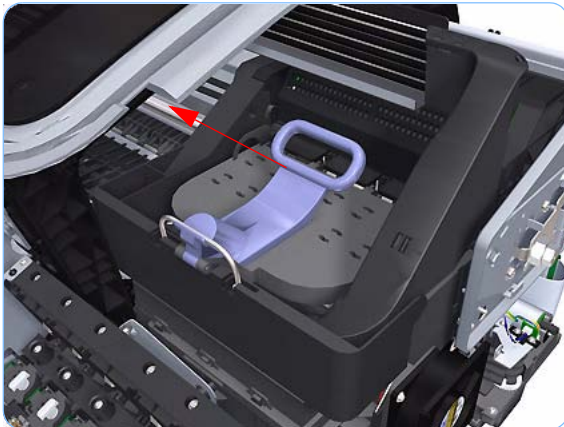
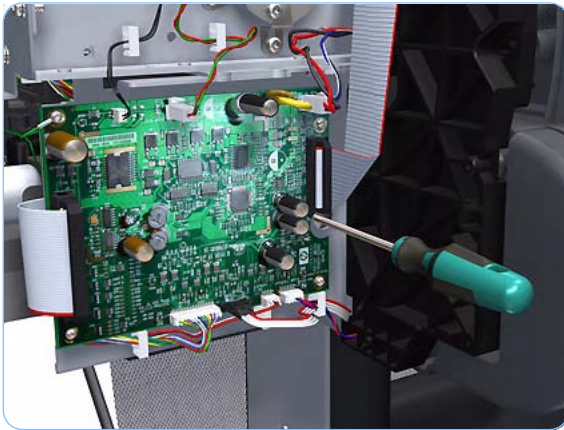

8. Push the Carriage Assembly into the print path.



- 9.** Unclip the small cover of the Carriage PCA.

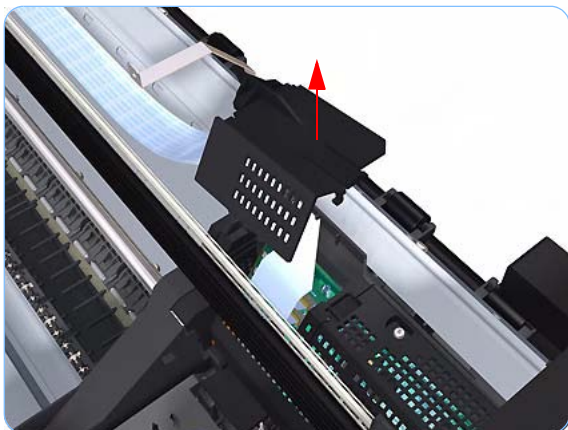

- 10.** Remove the small cover of the Carriage PCA.



- 11.** Disconnect the two ribbon cables of the Trailing Cables from the Carriage PCA.

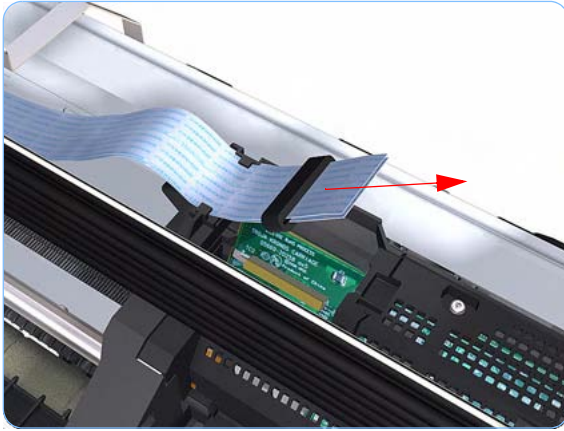

12. Straighten the two ribbon cables of the Trailing Cables and remove the Ferrite Core.

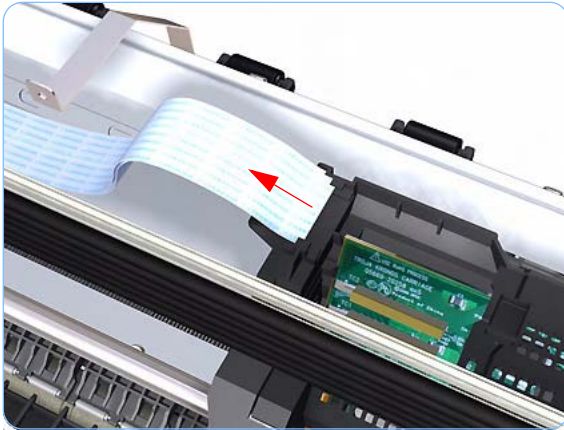

13. Slide the Trailing Cables out of the attachment clips of the Carriage Assembly.



14. Use a short torx screwdriver to remove the two T-15 screws that secure the center attachment of the Trailing Cables.

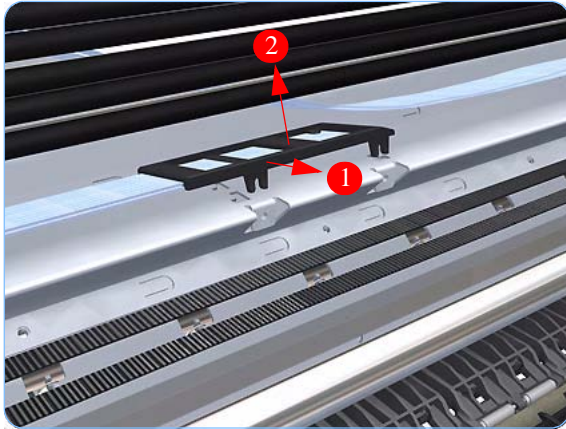

15. Unclip the center attachment of the Trailing Cables.



16. Remove the Trailing Cables from the two double sided adhesive pads that attach it to the printer.

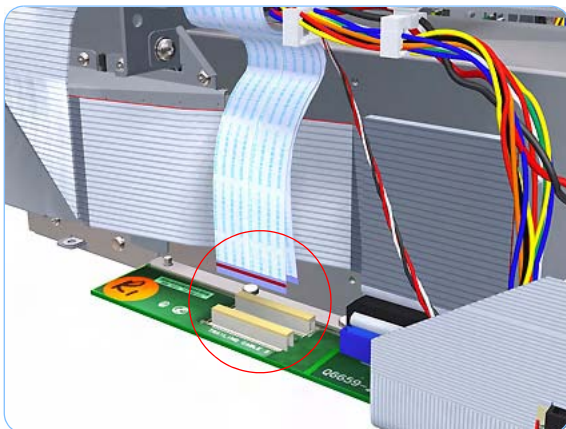

17. Disconnect the two ribbon cables of the Trailing Cables from the Electronics Module.

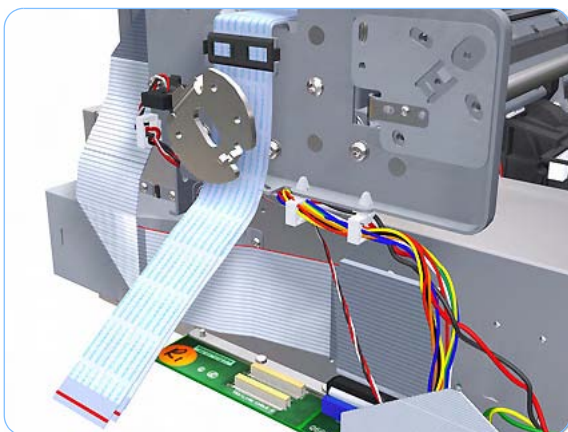

18. Unroute the Trailing Cables.

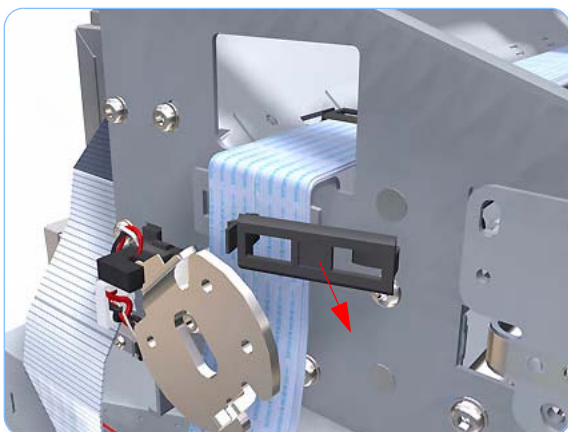

19. Unclip and remove the cable clamp of the Trailing Cables.

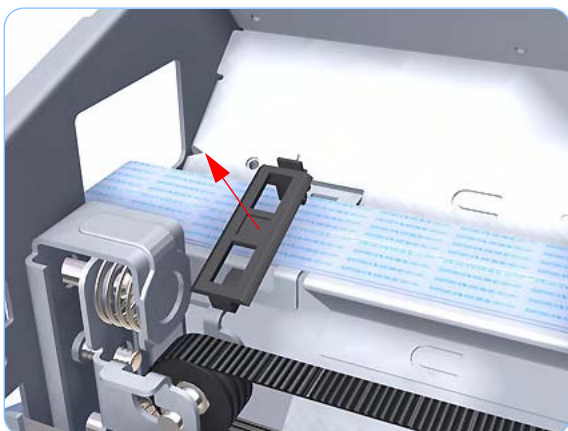

20. Unclip and remove the cable clamp of the Trailing Cables.

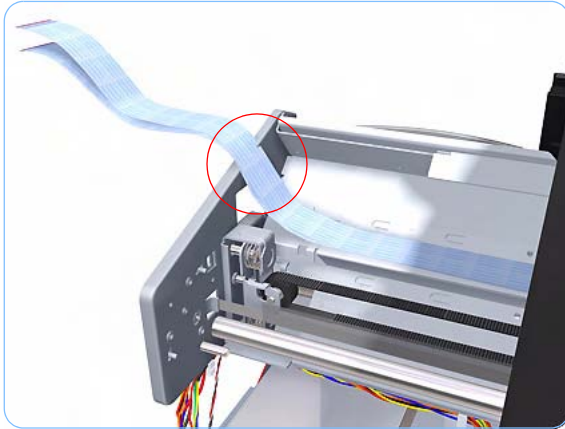

21. Unroute the Trailing Cables.

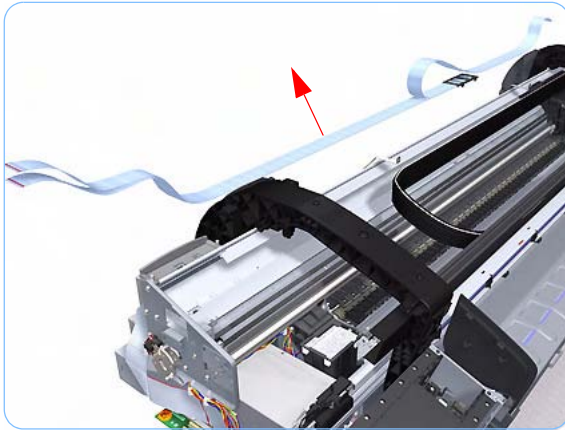

22. Remove the Trailing Cables from the printer.

Installation

Make sure you carry out the following actions during the installation of the Trailing Cable

1. Use an alcohol (from the Lubrification Kit or Tool Kit) dampened cloth to remove all traces of residual adhesive (remaining from the double sided pads removed in step 16) from the printer before applying new pads in the same positions as the original pads.

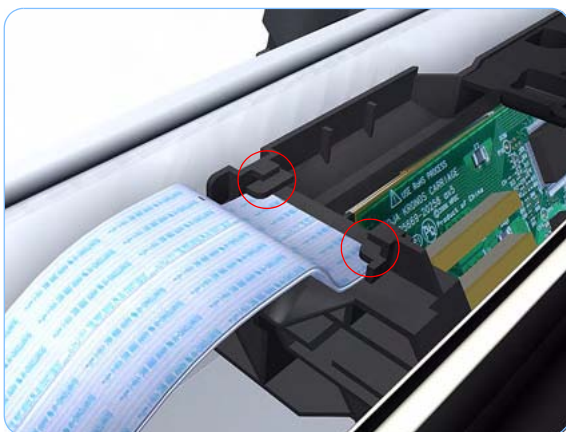

2. Make sure both ribbon cables of the Trailing Cable are routed below the lower attachment clips of the Carriage Assembly.

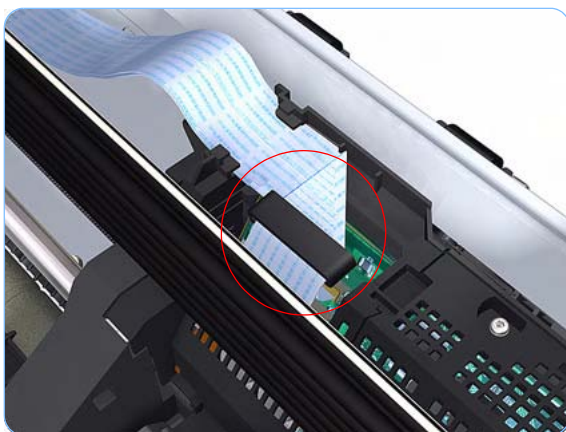

3. Make sure that the Ferrite Core is correctly positioned so that the small cover of the Carriage PCA closes correctly to avoid possible friction damage to the Trailing Cable during operation of the printer.

Carriage Assembly

Removal

Switch off the printer and remove the power cable.

1. Remove the Front Cover (refer to page 8-7).
2. Remove the Right Cover (refer to page 8-18).
3. Remove the Left Cover (refer to page 8-21).
4. Remove the Cutter Assembly (refer to page 8-35).
5. Remove the Front Panel (refer to page 8-40).
6. Remove the Top Cover (refer to page 8-42).
7. Remove the Window Position Sensor (refer to page 8-45).
8. Remove the Ink Supply Tubes Support Rail (refer to page 8-47).
9. Remove the Encoder Strip (with spring and attachment nut) (refer to page 8-74).
10. If necessary manually move the Carriage Assembly fully right into the docking station.
11. Use a short torx screwdriver to remove the two T-15 screws that secure the center attachment of the Trailing Cables.



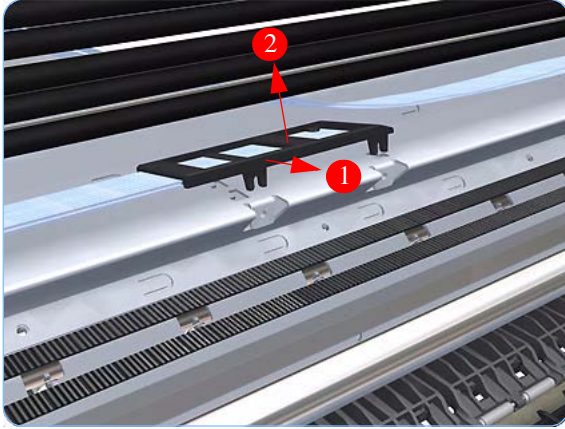

12. Unclip the center attachment of the Trailing Cables.



13. Remove the Trailing Cables from the two double sided adhesive pads that attach it to the printer.

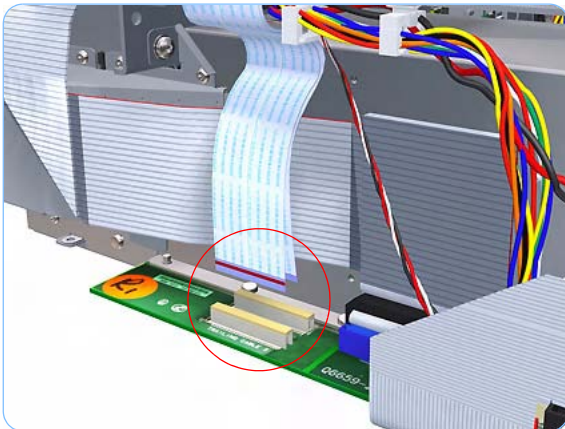

14. Disconnect the two ribbon cables of the Trailing Cables from the Electronics Module.

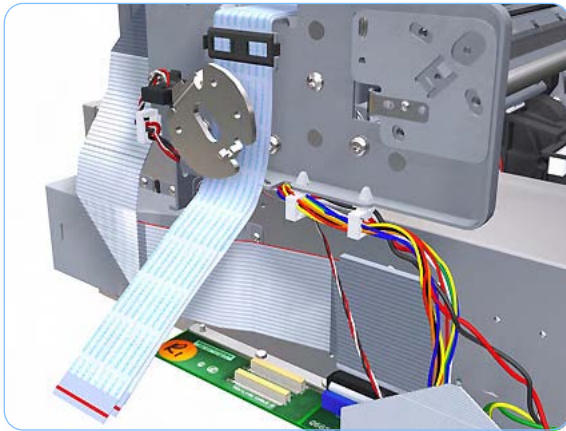

15. Unroute the Trailing Cables.

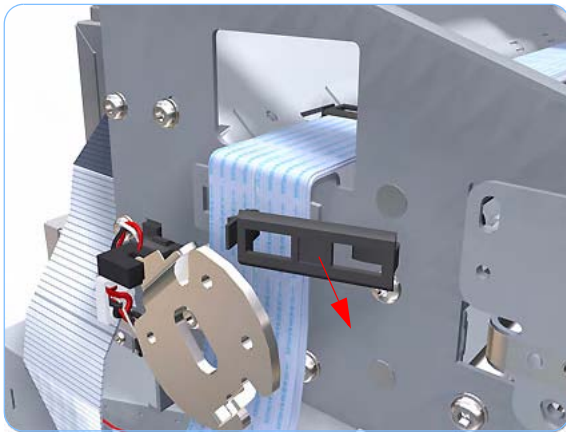

16. Unclip and remove the cable clamp of the Trailing Cables.

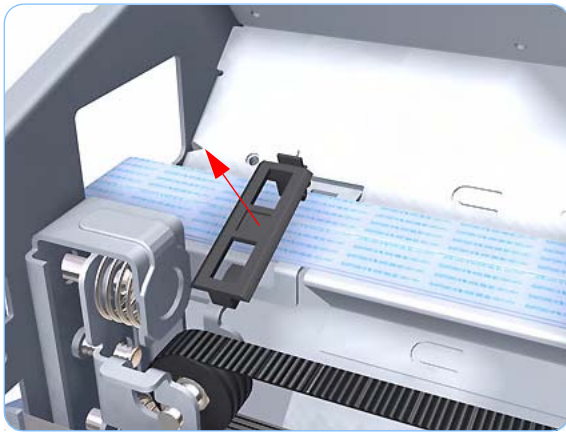

17. Unclip and remove the cable clamp of the Trailing Cables.

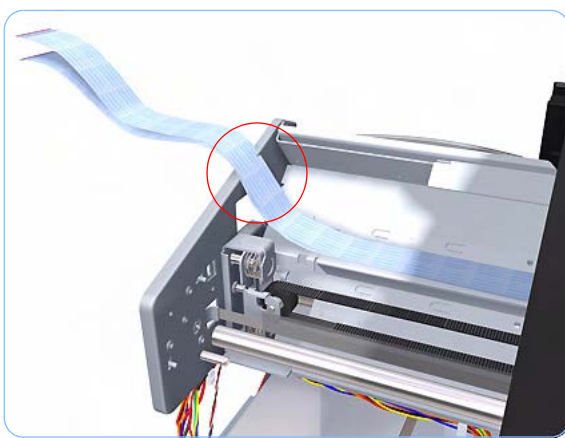

18. Unroute the Trailing Cables.

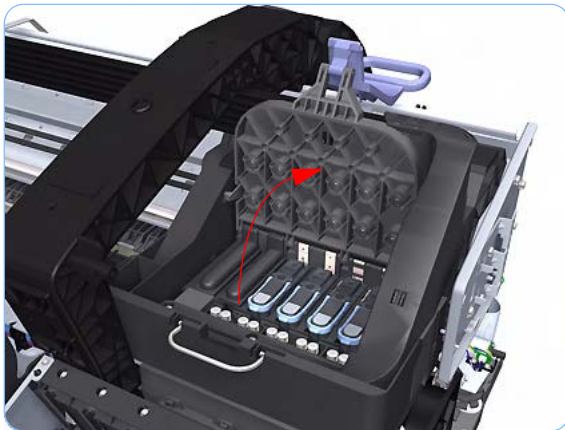

19. Open the Carriage Cover.
The illustration shows the Z2100 which only has four Printheads, for the Z3100 there are six Printheads.

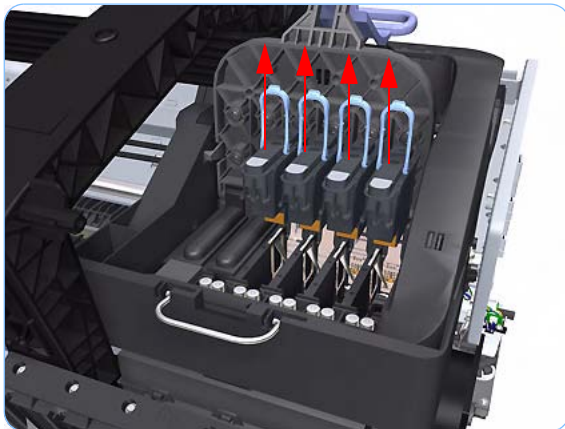

20. Remove all the Printheads.

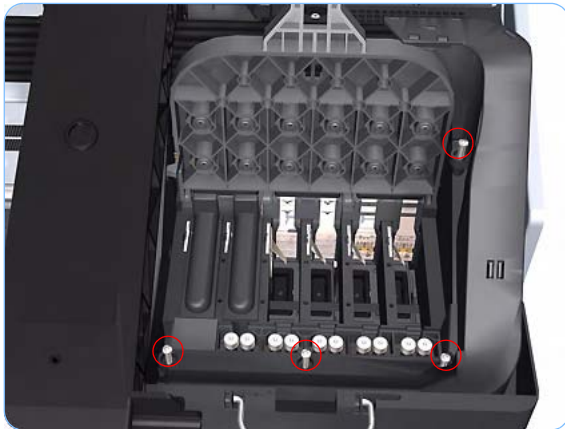

21. Remove the four T-15 screws that secure the Ink Supply Tubes to the Carriage Assembly.

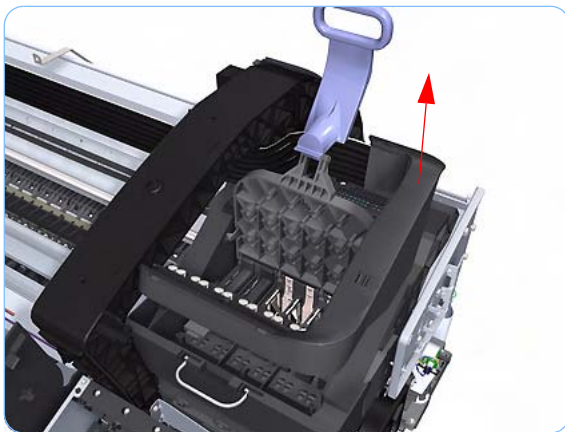

22. Carefully lift out the Ink Supply Tubes.



23. Close and lock the Carriage Cover.

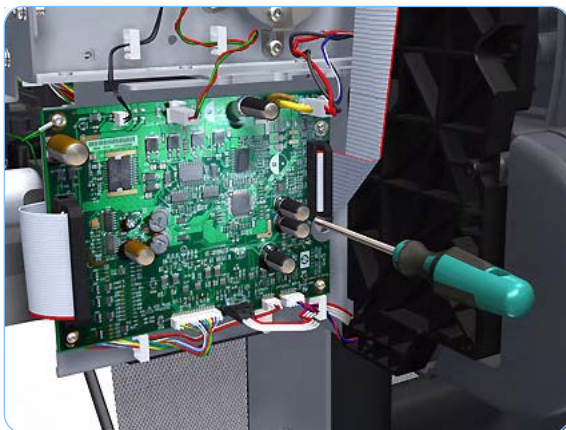

24. Loosen the T-10 uncapping screw sufficiently so you can manually move the Carriage Assembly in step 25.

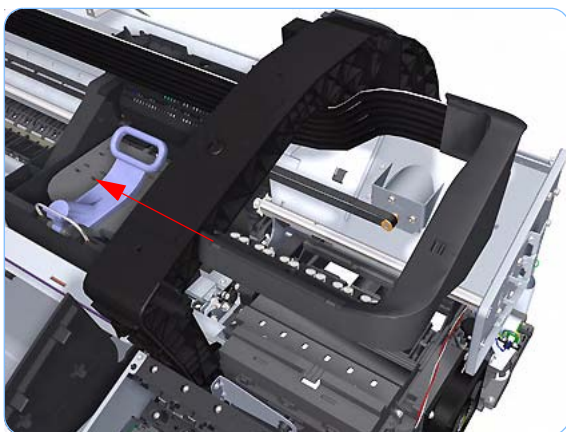

25. Push the Carriage Assembly into the print path.

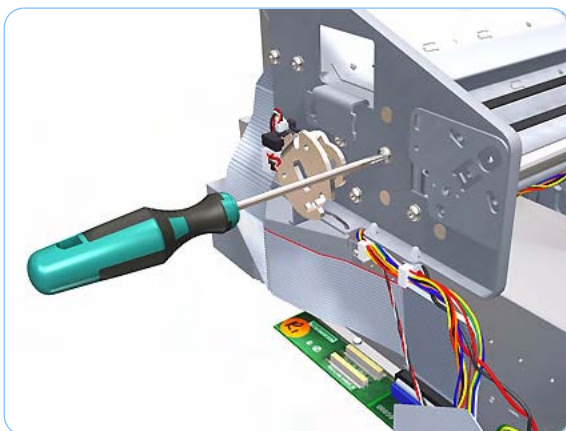

26. Loosen the T-15 screw Belt Tensioner to the printer to remove the tension from the belt.

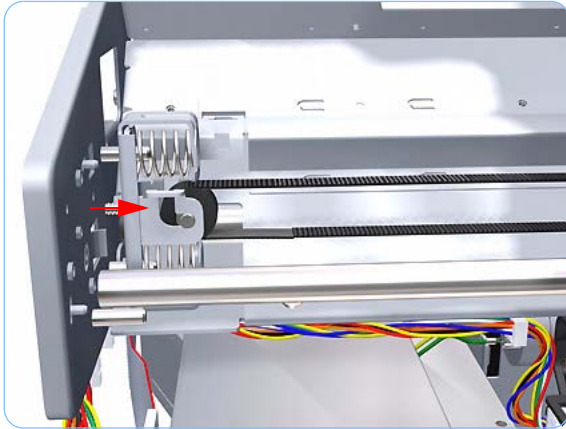

27. Leave the Belt Tensioner in place with all the tension removed.

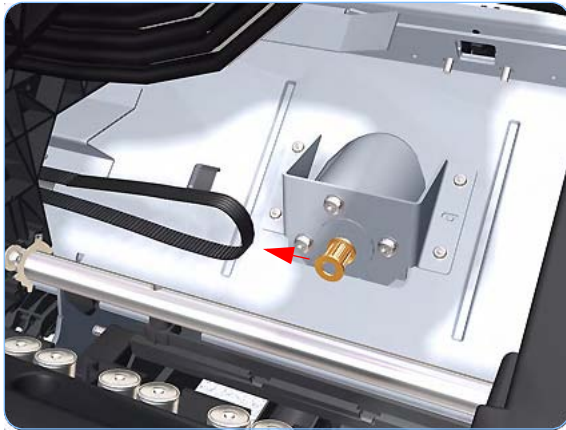

28. Remove the Belt Assembly from the Scan-Axis Motor drive wheel.

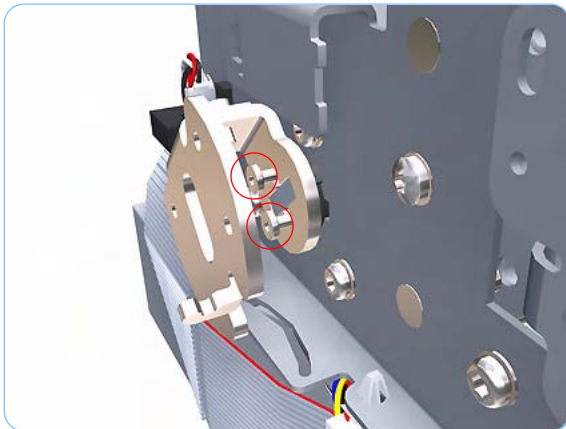

29. Remove the two T-15 screw that secure the Media Lever attachment plate.

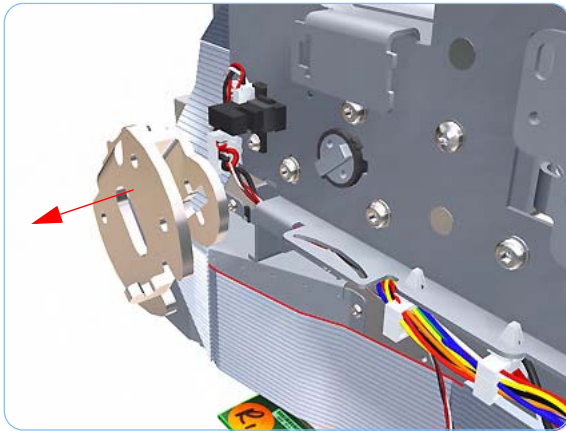

30. Remove the Media Lever attachment plate.

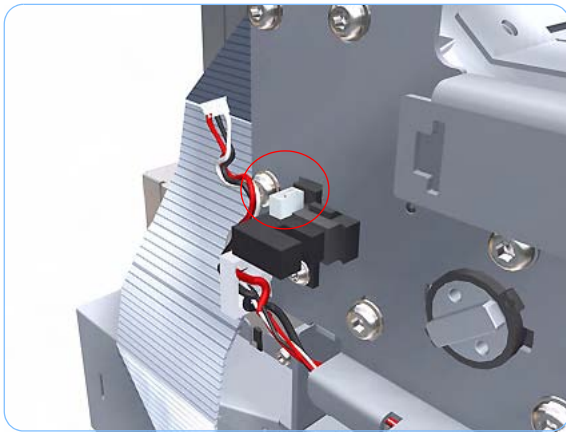

31. Disconnect the Pinchwheel Lifter Sensor.

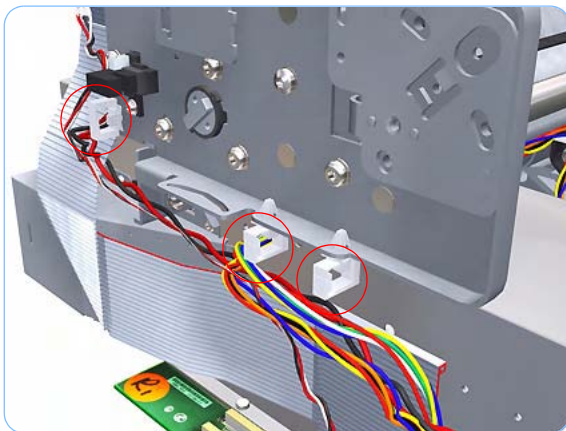

32. Unroute the cables from the cable clamps on the Scan Side Panel.

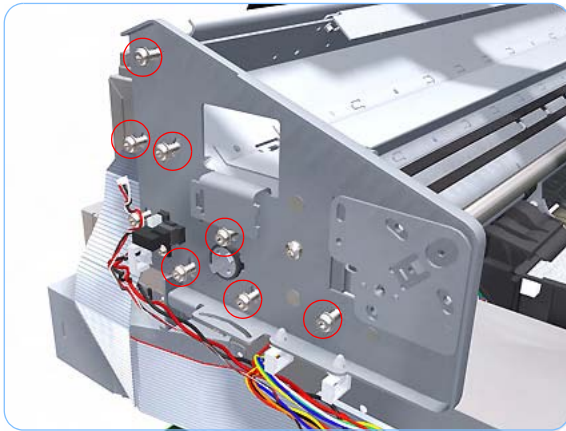

33. Remove the six T-15 screw that secure the Scan Side Panel to the printer.

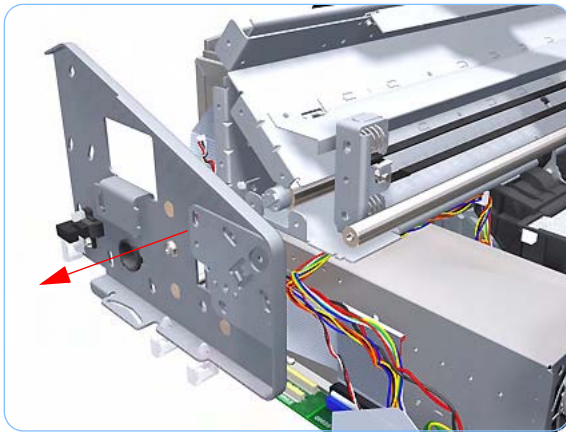

34. Remove the Scan Side Panel.



35. Carefully slide the Carriage Assembly and Belt Assembly out of the printer.

Before you reinstall the Carriage Assembly use an alcohol dampened cloth to remove all traces of residual adhesive (remaining from the double sided pads removed in step 13) from the printer before applying new pads in the same positions as the original pads.

Carriage Rear Bushing

Removal

Switch off the printer and remove the power cable.

1. Remove the Front Cover (refer to page 8-7).
2. Remove the Right Cover (refer to page 8-18).
3. Remove the Left Cover (refer to page 8-21).
4. Remove the Cutter Assembly (refer to page 8-35).
5. Remove the Front Panel (refer to page 8-40).
6. Remove the Top Cover (refer to page 8-42).
7. Remove the Window Position Sensor (refer to page 8-45).
8. Remove the Ink Supply Tubes Support Rail (refer to page 8-47).
9. Remove the Encoder Strip (with spring and attachment nut) (refer to page 8-74).
10. Remove the Carriage Assembly (refer to page 8-85).
11. Squeeze the left hand clip of the Carriage Rear Bushing sufficiently to be able to release it from the Carriage Assembly.



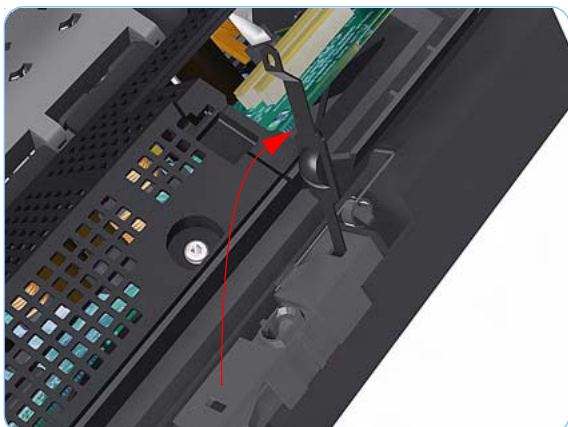

- 12.** Rotate the Carriage Rear Bushing vertically and remove it from the Carriage Assembly.



When you reinstall the Carriage Rear Bushing, use the Oil and Oil Dispenser from the Lubrication Kit to add 2-3 drops of oil to the small depression in it.

Belt Assembly

Removal

Switch off the printer and remove the power cable.

1. Remove the Carriage Assembly (refer to page 8-85).
2. Slide the Belt Assembly out of the attachment on the Carriage Assembly.

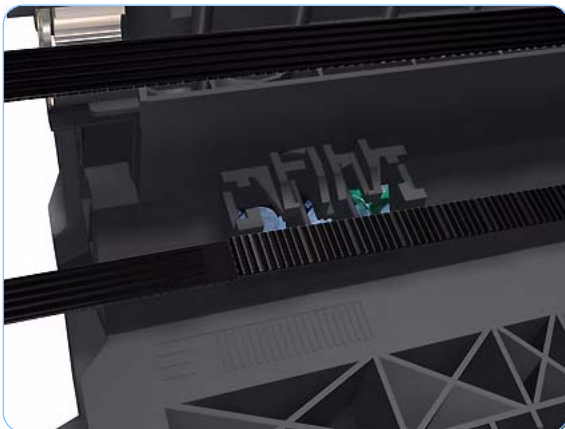

3. Remove the pulley to release the Belt Assembly from the Belt Tensioner.



Scan-Axis Motor

Removal

Switch off the printer and remove the power cable.

1. Remove the Right Cover (refer to page 8-18).
2. Remove the Left Cover (refer to page 8-21).
3. Remove the Front Panel (refer to page 8-40).
4. Loosen the T-10 uncapping screw sufficiently so you can manually move the Carriage Assembly in step 5.

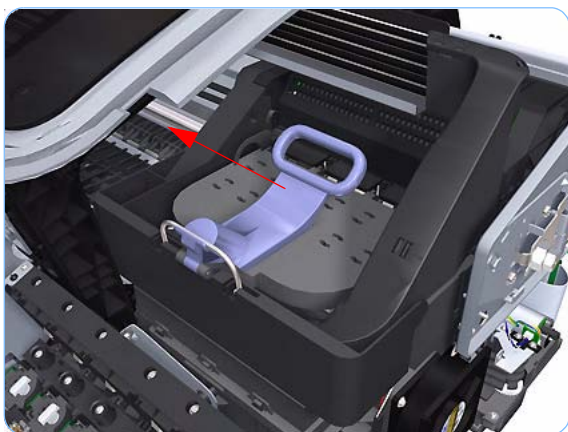
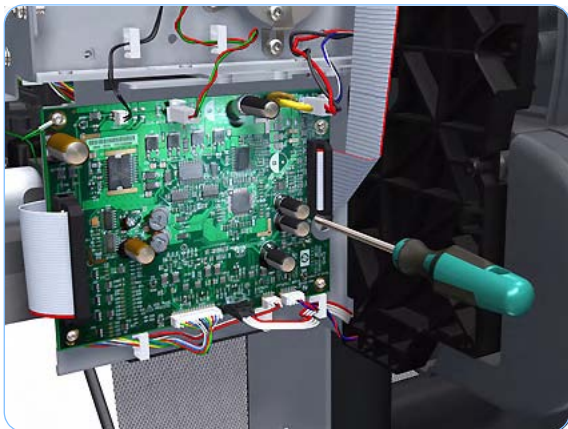

5. Push the Carriage Assembly into the print path.

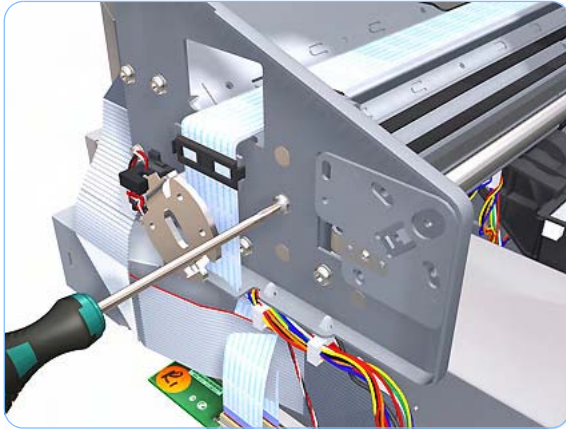

6. Loosen the T-15 screw Belt Tensioner to the printer to remove the tension from the belt.

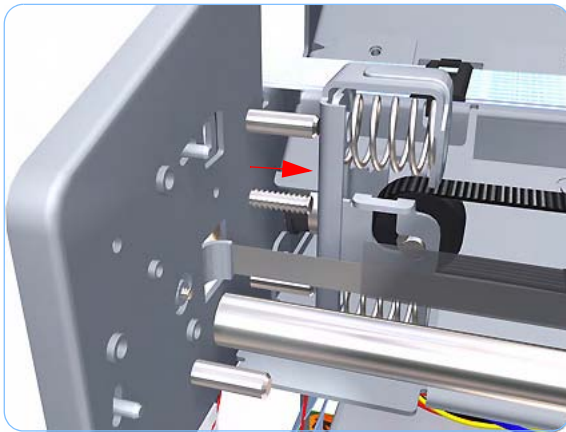

7. Leave the Belt Tensioner in place.



8. Remove the Belt Assembly from the drive wheel of the Scan-Axis Motor.



- 9.** Remove three T-15 screws that secure the Scan-Axis Motor to the printer.

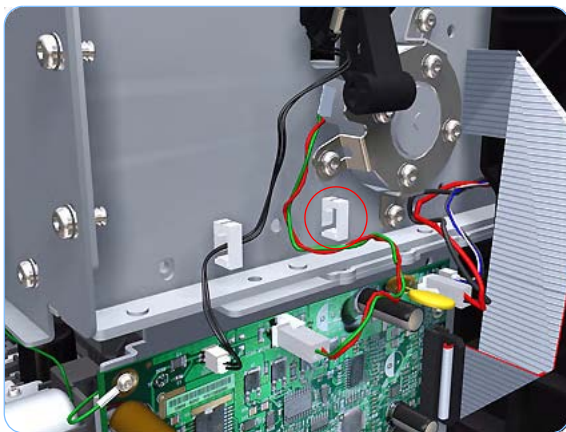

- 10.** Unroute the Scan-Axis Motor supply cable from the cable clamp.

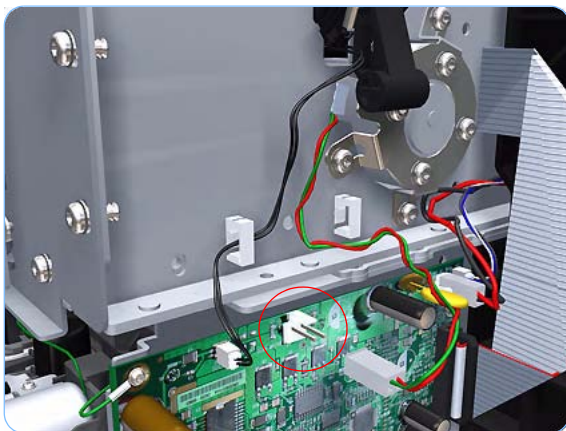

- 11.** Disconnect the Scan-Axis Motor supply connector from PrintMech PCA.

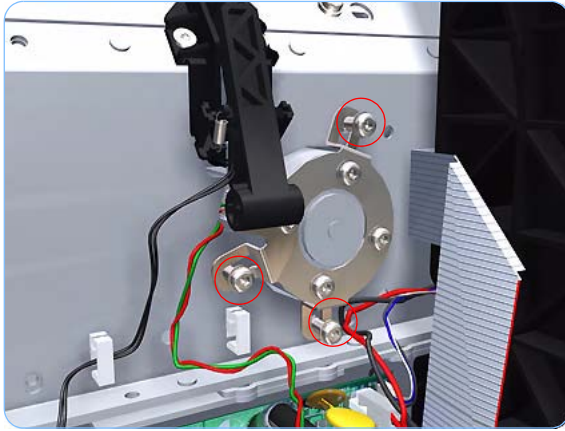

12. Remove three T-15 screws that secure the Scan-Axis Motor to the printer.

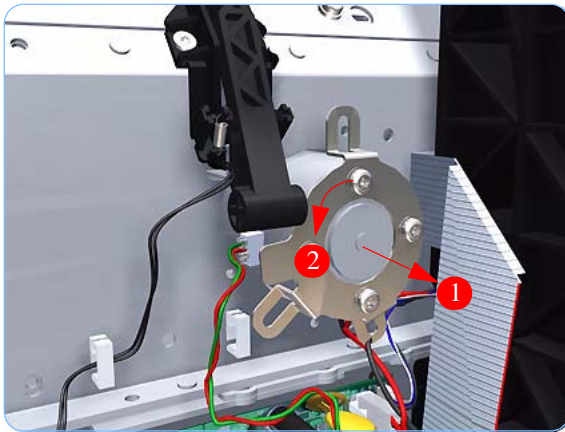

13. Carefully pull the Scan-Axis Motor out of the printer (10 mm) until you can rotate it approximately 30 degrees counterclockwise.

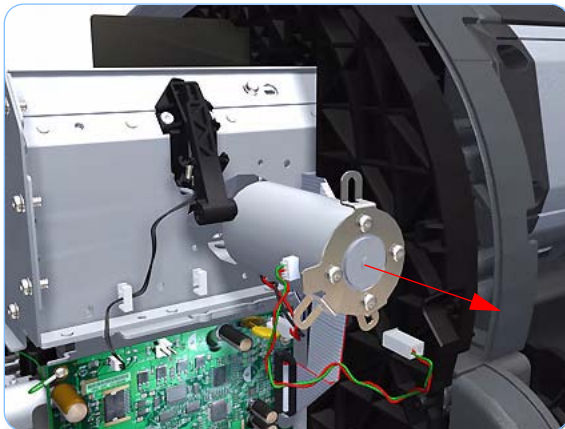

14. Remove the Scan-Axis Motor from the printer.

Carriage Rail Oiler

Removal

Switch off the printer and remove the power cable.

1. Remove the Right Cover (refer to page 8-18).
2. Remove the T-15 Carriage Rail Oiler attachment screw.



3. Remove the Carriage Rail Oiler from the printer.

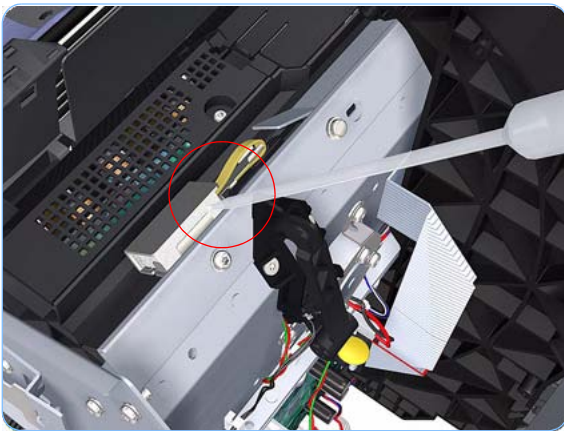

When you reinstall the Carriage Rail Oiler, use the Oil and Oil Dispenser from the Lubrification Kit to add 2-3 drops of oil to the foam of the Carriage Rail Oiler and in the small depression of the Carriage Rear Bushing.

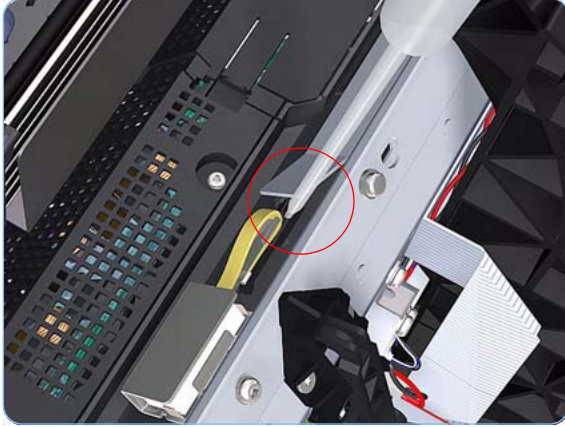

Color Sensor (ESP)

Removal

Switch off the printer and remove the power cable.

1. Remove the Right Cover (refer to page 8-18).
2. Remove the Left Cover (refer to page 8-21).
3. Remove the Front Panel (refer to page 8-40).
4. Remove the Top Cover (refer to page 8-42).
5. Remove the Window Position Sensor (refer to page 8-45).
6. Remove the Ink Supply Tubes Support Rail (refer to page 8-47).
7. Open the Carriage Cover.
The illustration shows the Z2100 which only has four Printheads, for the Z3100 there are six Printheads.

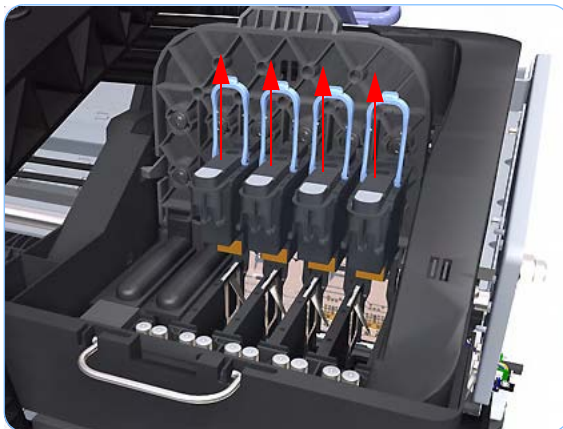
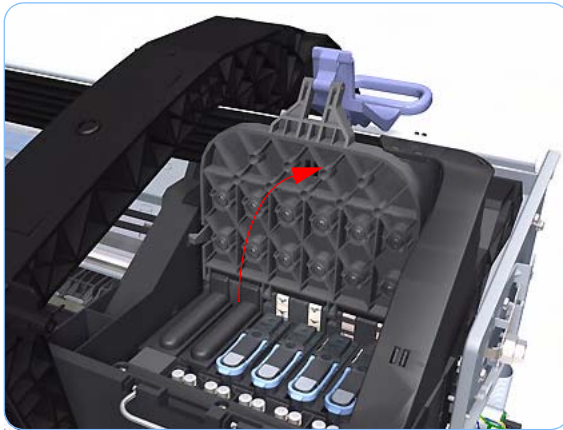

8. Remove all the Printheads.



- 9.** Remove the four T-15 screws that secure the Ink Supply Tubes to the Carriage Assembly.

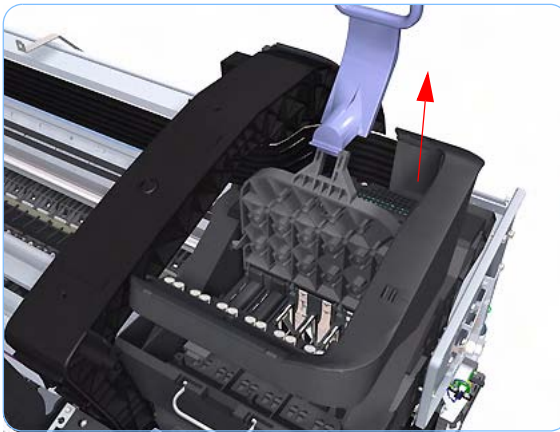

- 10.** Carefully lift out the Ink Supply Tubes.



- 11.** Close and lock the Carriage Cover.



12. Carefully move the Ink Supply Tubes into the print path.

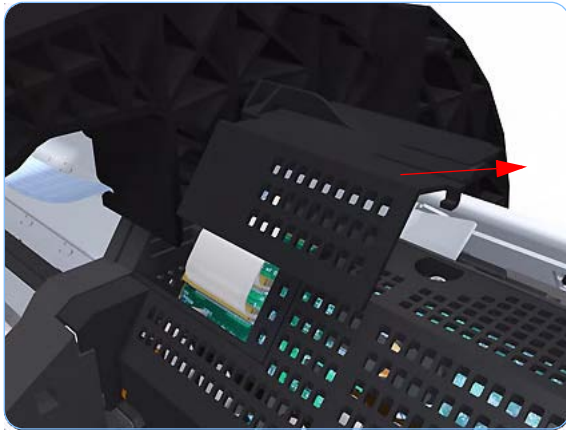

13. Unclip and slide off the small cover of the Carriage Assembly Carriage PCA.



14. Remove one T-15 screws that secures the large cover of the Carriage PCA.

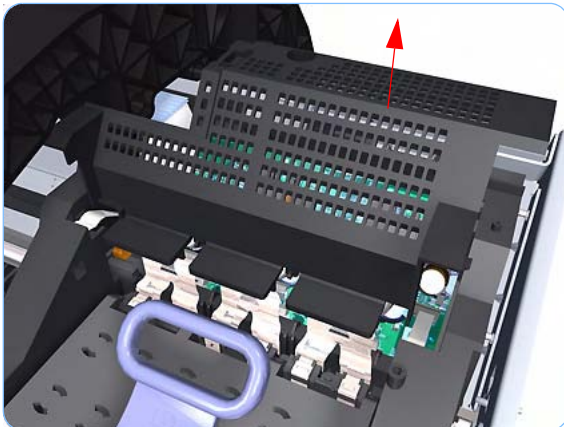

15. Remove the large cover of the Carriage PCA.

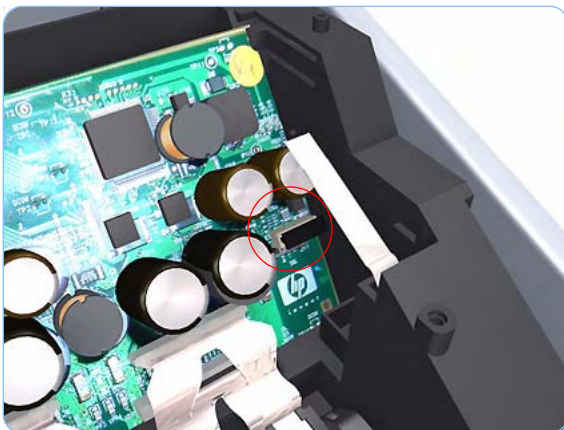

16. Disconnect the Color Sensor (ESP) electrical connection from the Carriage PCA.

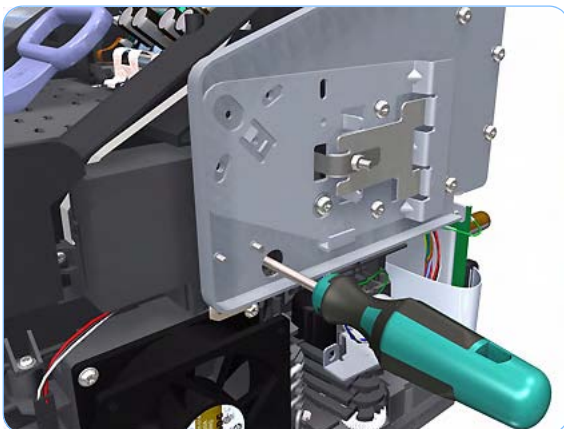

17. Remove one T-10 screw that secures the Color Sensor (ESP) to the Carriage Assembly.

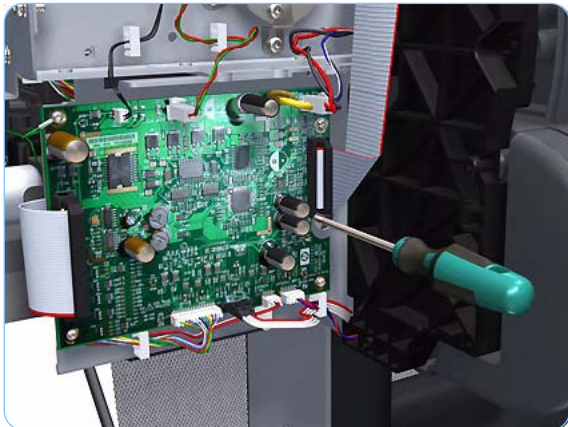

18. Loosen the T-10 uncapping screw sufficiently so you can manually move the Carriage Assembly in step 25.

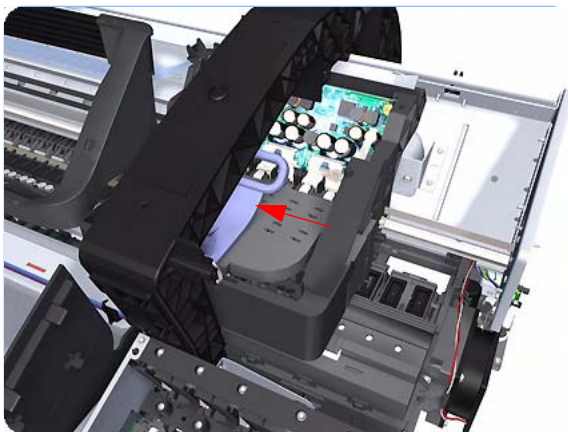

19. Push the Carriage Assembly into the print path enough to allow access to the Color Sensor (ESP).

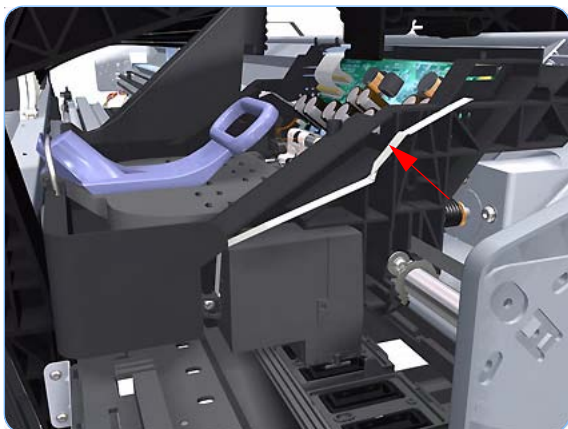

20. Carefully unroute the Color Sensor (ESP) cable from the Carriage Assembly.

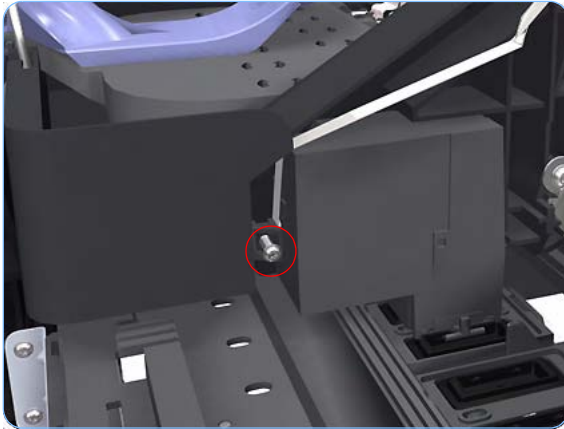

- 21.** Remove one T-10 screw that secures the Color Sensor (ESP) to the Carriage Assembly.

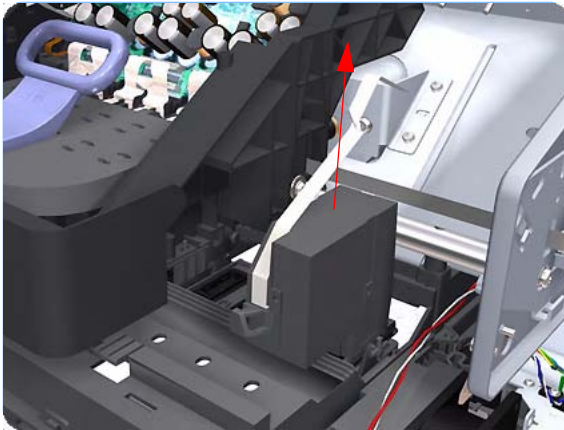

- 22.** Remove the Color Sensor (ESP) from Carriage Assembly.

When you reinstall the Color Sensor (ESP), be very careful not to overtighten the attachment screw because this will damage cause irreparable damage to it.

Take care when you route the Color Sensor (ESP) cable so it lays flat and is not twisted. This ensures that when you reconnect it to the connector in the Carriage Assembly it is connected correctly. If the cable has been twisted during the routing there is a danger that the connection is inverted.

Line Sensor

Removal

Switch off the printer and remove the power cable.

1. Remove the Right Cover (refer to page 8-18).
2. Remove the Left Cover (refer to page 8-21).
3. Remove the Front Panel (refer to page 8-40).
4. Remove the Top Cover (refer to page 8-42).
5. Remove the Window Position Sensor (refer to page 8-45).
6. Remove the Ink Supply Tubes Support Rail (refer to page 8-47).
7. Open the Carriage Cover.
The illustration shows the Z2100 which only has four Printheads, for the Z3100 there are six Printheads.

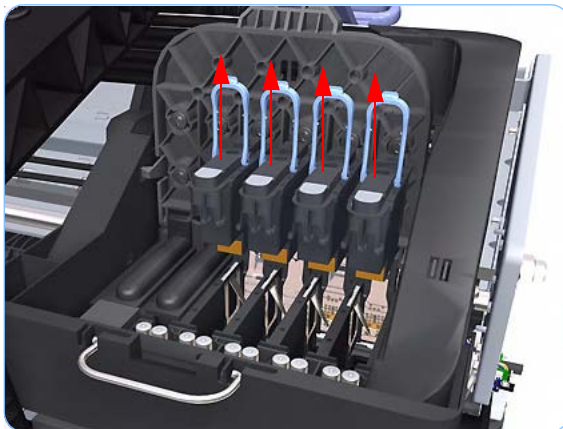
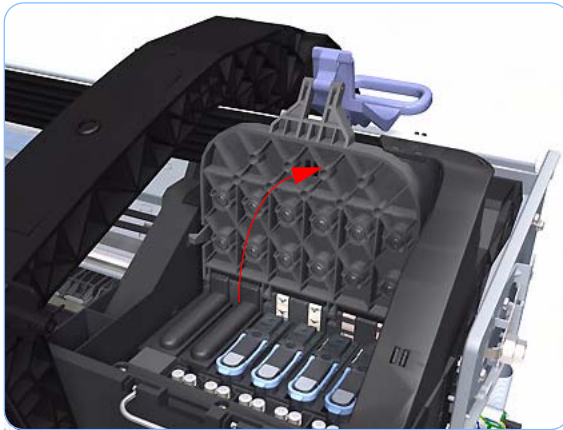

8. Remove all the Printheads.



- 9.** Remove the four T-15 screws that secure the Ink Supply Tubes to the Carriage Assembly.

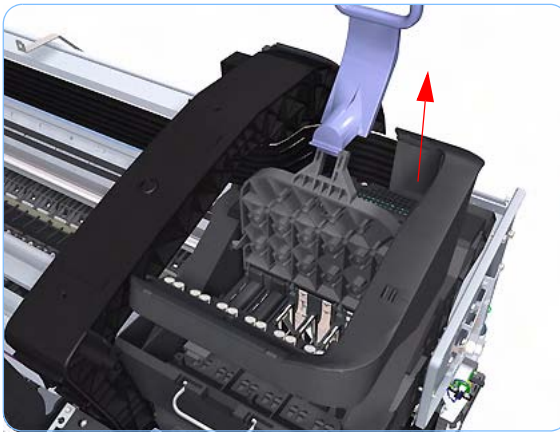

- 10.** Carefully lift out the Ink Supply Tubes.

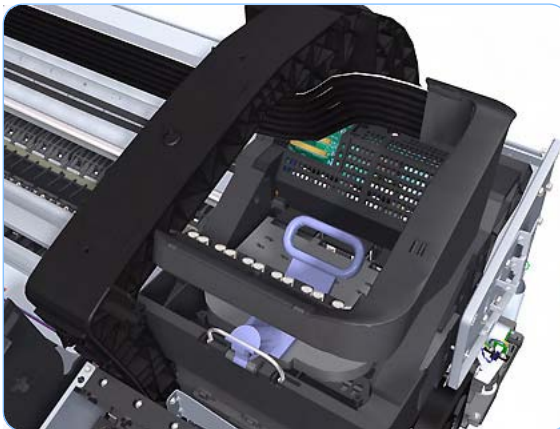

- 11.** Close and lock the Carriage Cover.

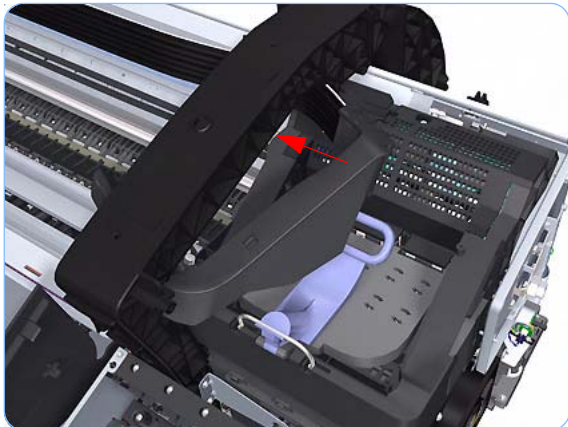

12. Carefully move the Ink Supply Tubes into the print path.



13. Unclip and slide off the small cover of the Carriage Assembly Carriage PCA.



14. Remove one T-15 screws that secures the large cover of the Carriage PCA.

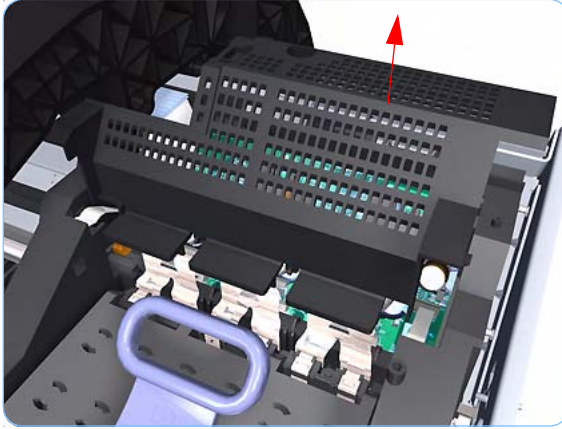

15. Remove the large cover of the Carriage PCA.

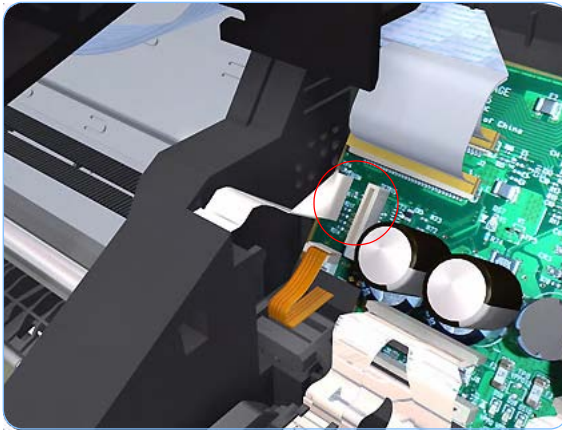

16. Disconnect the Line Sensor electrical connection from the Carriage PCA.

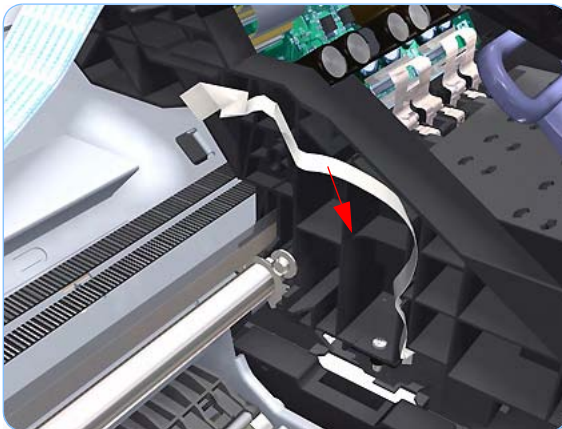

17. Carefully unrout the Line Sensor cable from the Carriage Assembly.

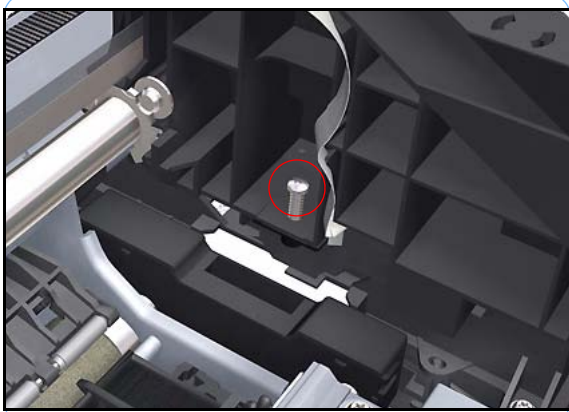

18. Remove one T-10 screw that secures the Line Sensor to the Carriage Assembly.

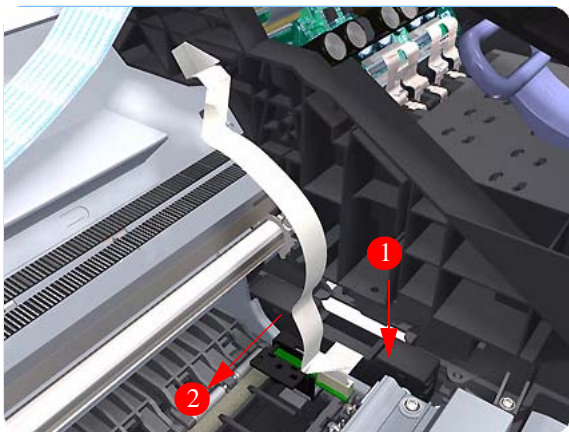

19. Remove the Line Sensor from Carriage Assembly.

Carriage Cover (includes Carriage Latch)

Removal

Switch off the printer and remove the power cable.

1. Remove the Right Cover (refer to page 8-18).
2. Remove the Left Cover (refer to page 8-21).
3. Remove the Front Panel (refer to page 8-40).
4. Remove the Top Cover (refer to page 8-42).
5. Remove the Window Position Sensor (refer to page 8-45).
6. Remove the Ink Supply Tubes Support Rail (refer to page 8-47).
7. Open the Carriage Cover.
The illustration shows the Z2100 which only has four Printheads, for the Z3100 there are six Printheads.

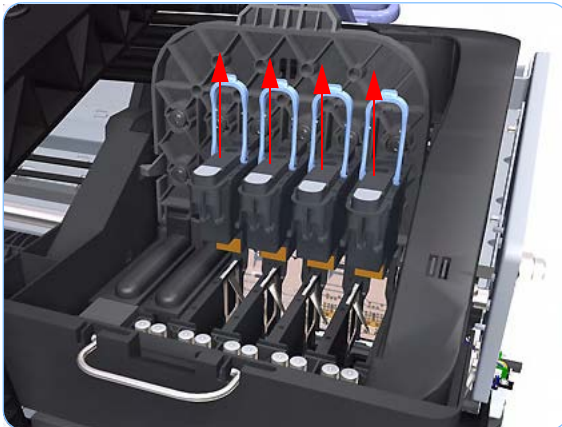
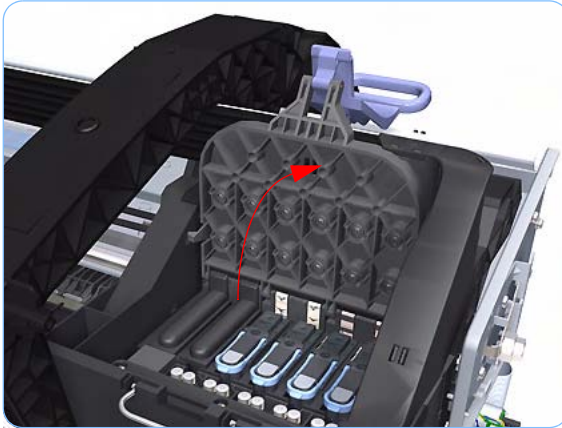

8. Remove all the Printheads.



- 9.** Remove the four T-15 screws that secure the Ink Supply Tubes to the Carriage Assembly.

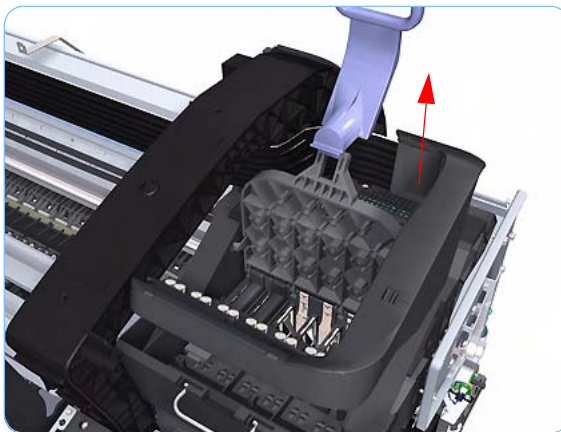

- 10.** Carefully lift out the Ink Supply Tubes.

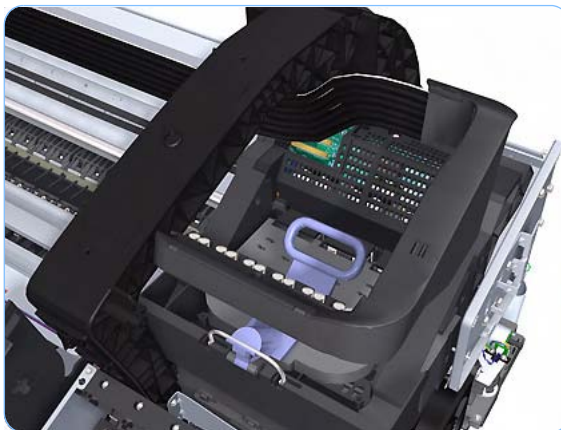

- 11.** Close and lock the Carriage Cover.



12. Carefully move the Ink Supply Tubes into the print path.

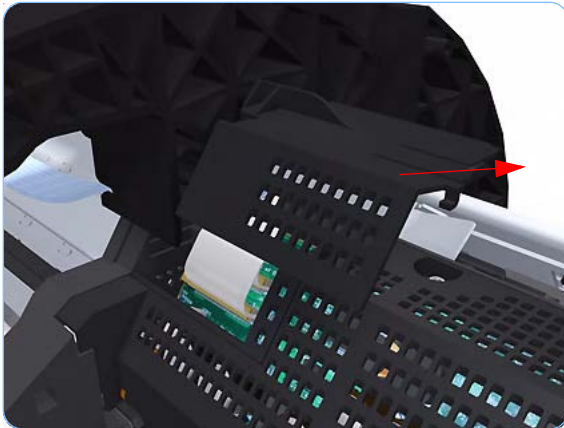

13. Unclip and slide off the small cover of the Carriage Assembly Carriage PCA.



14. Remove one T-15 screws that secures the large cover of the Carriage PCA.

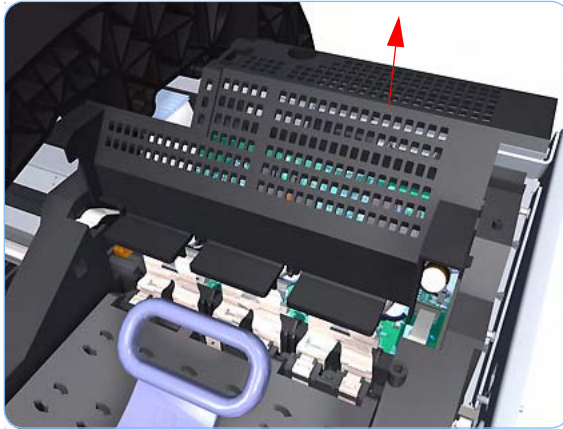

15. Remove the large cover of the Carriage PCA.

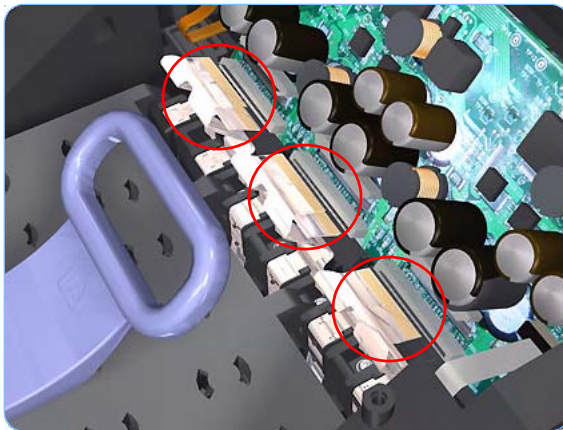

16. Disconnect the six ribbon cables of Carriage Cover from the Carriage Assembly PCB.

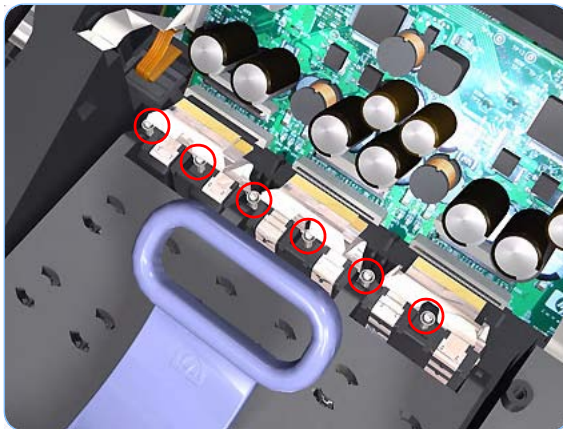

17. Remove six T-10 screws that secure the Carriage Assembly Cover hinge.

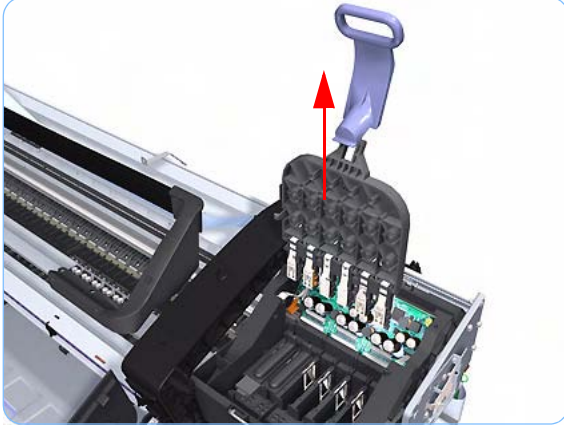

- 18.** Carefully lift the Carriage Cover in the vertical position to remove it from the Carriage Assembly.

Carriage PCA

Removal

Switch off the printer and remove the power cable.

1. Remove the Right Cover (refer to page 8-18).
2. Remove the Left Cover (refer to page 8-21).
3. Remove the Front Panel (refer to page 8-40)
4. Remove the Top Cover (refer to page 8-42).
5. Remove the Window Position Sensor (refer to page 8-45).
6. Remove the Ink Supply Tubes Support Rail (refer to page 8-47).
7. Open the Carriage Cover.
The illustration shows the Z2100 which only has four Printheads, for the Z3100 there are six Printheads.

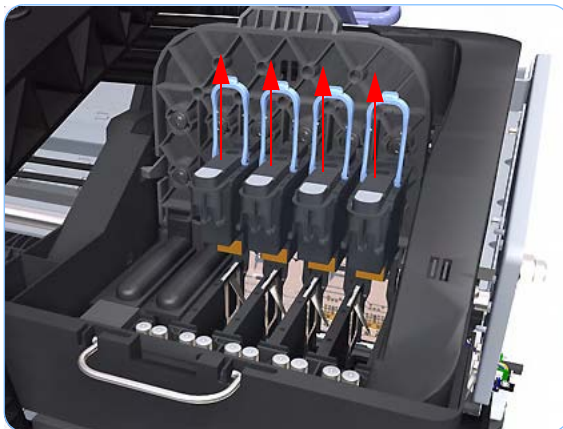
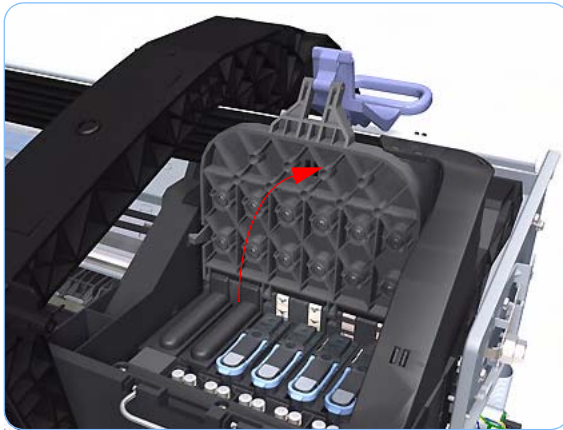

8. Remove all the Printheads.



- 9.** Remove the four T-15 screws that secure the Ink Supply Tubes to the Carriage Assembly.

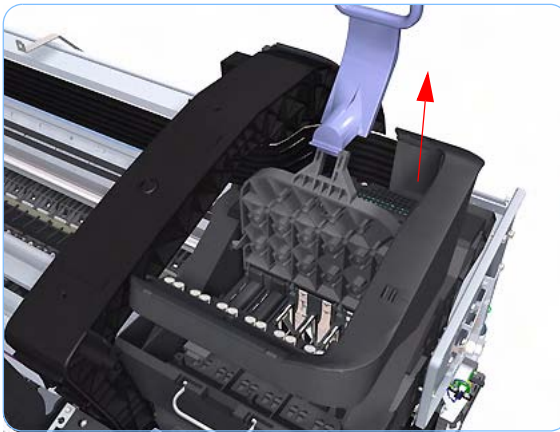

- 10.** Carefully lift out the Ink Supply Tubes.



- 11.** Close and lock the Carriage Cover.



12. Carefully move the Ink Supply Tubes into the print path.

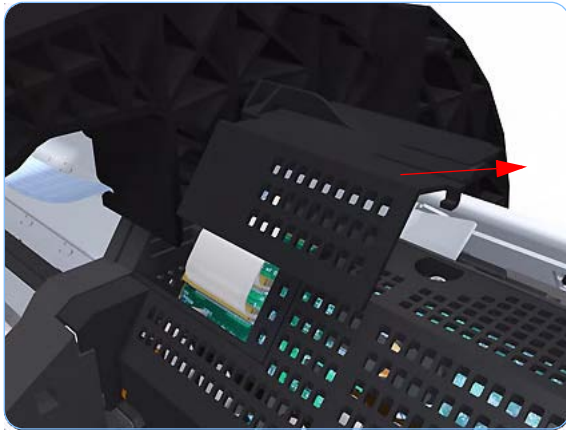

13. Unclip and slide off the small cover of the Carriage Assembly Carriage PCA.



14. Remove one T-15 screws that secures the large cover of the Carriage PCA.

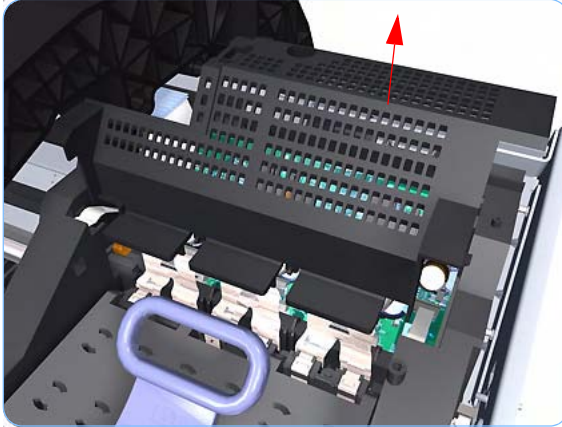

15. Remove the large cover of the Carriage PCA.

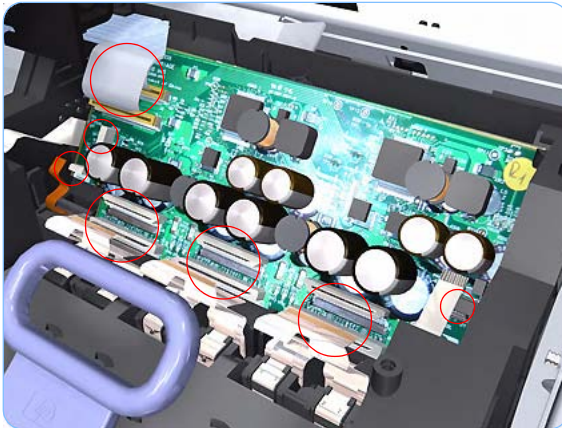

16. Disconnect the ten ribbon cables from the Carriage Assembly PCB.

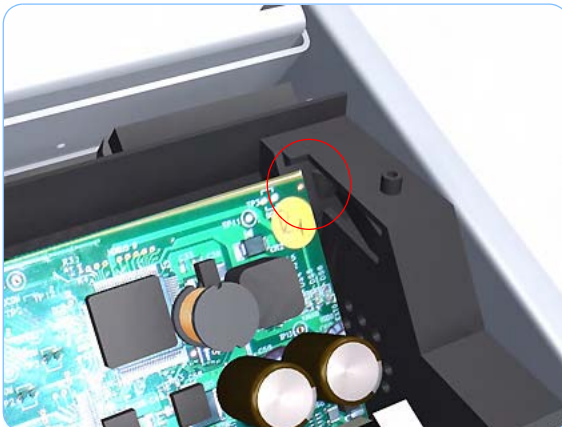

17. Press the locking clip to release the Carriage Assembly PCB from the carriage.

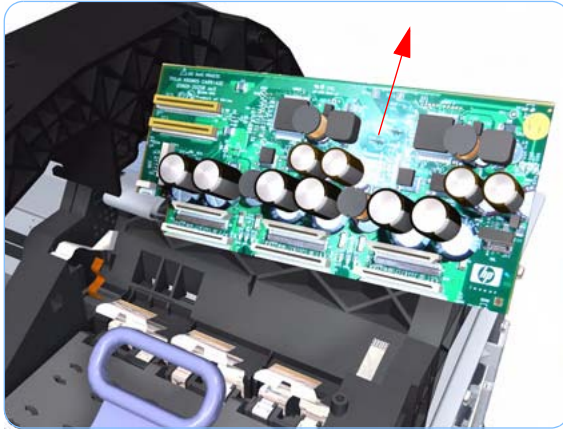

18. Remove the Carriage Assembly PCB from the carriage.

Right Ink Supply Station

Removal

Switch off the printer and remove the power cable.

1. Remove the Right Cover (refer to page 8-18).
2. Remove two T-10 screws that secure the Right Side Plate of the Ink Supply Station.

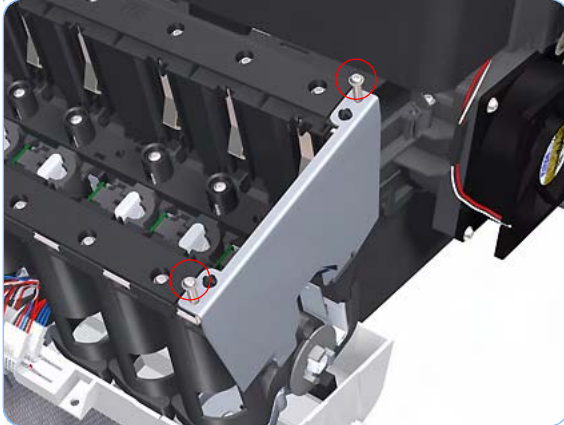

3. Remove the Right Side Plate of the Right Ink Supply Station.

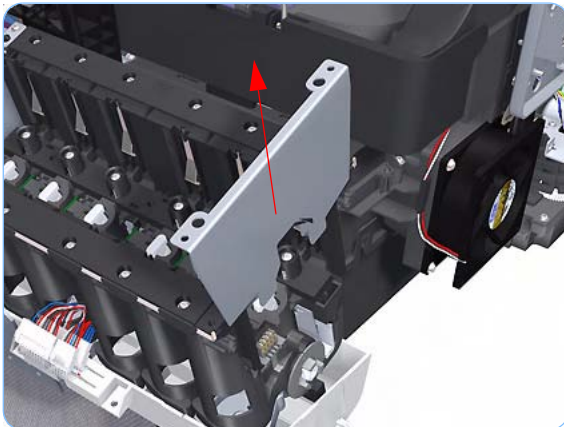

4. Remove two T-10 screws that secure the Left Side Plate of the Right Ink Supply Station.

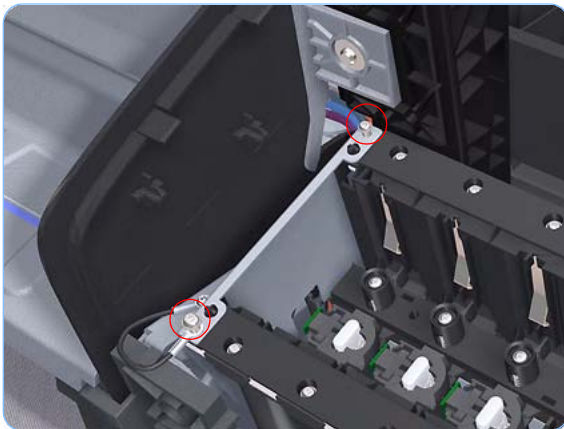

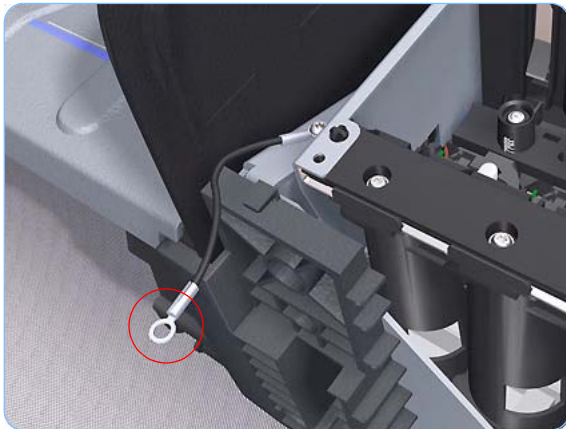

5. Remove the Right Ink Supply Station bonding cable.

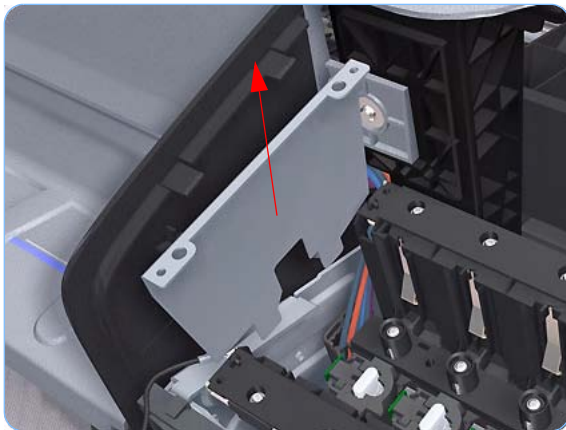

6. Remove the Right Side Plate of the Right Ink Supply Station.

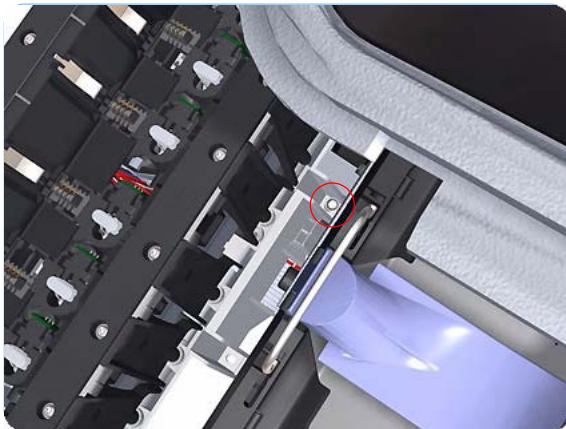

7. Remove the T-15 screw that secures the Right Ink Supply Station to the printer.

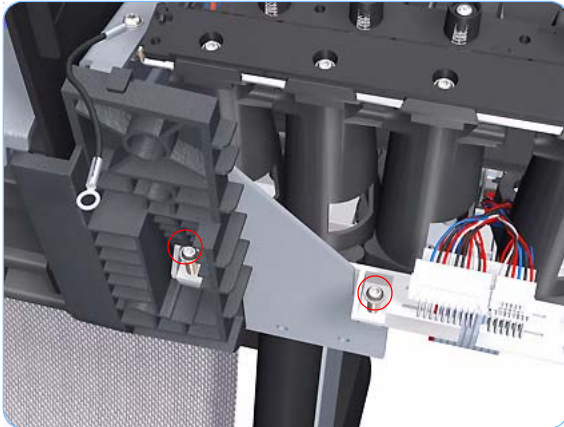

- 8.** Remove the two T-15 screws that secure the Right Ink Supply Station to the printer.

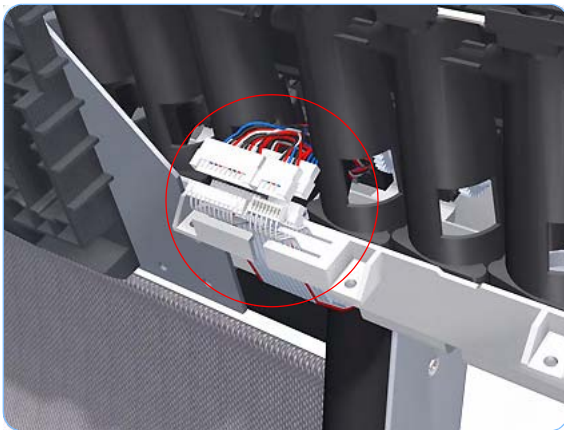

- 9.** Disconnect the three connectors from the Right Ink Supply Station.

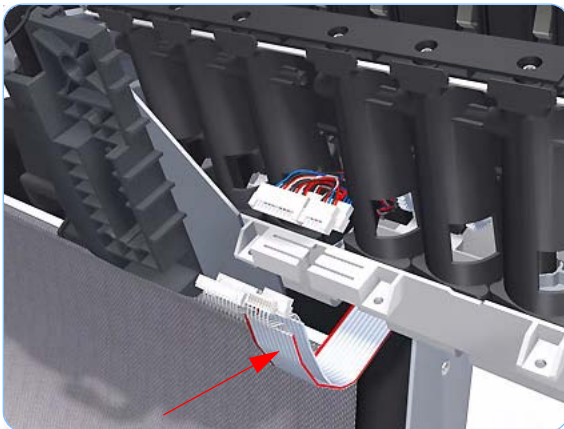

- 10.** Unroute the three cables from the Right Ink Supply Station.

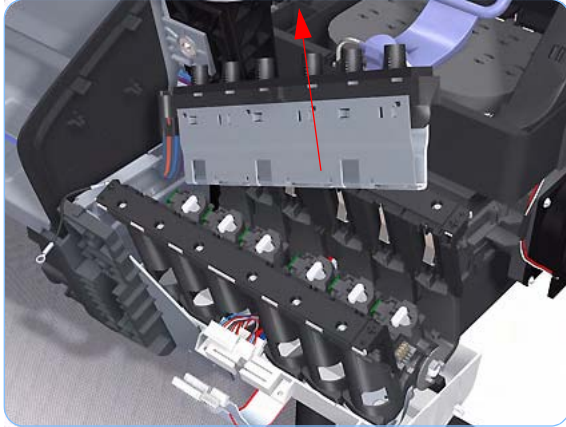

- 11.** Carefully lift the Cartridge Tubes Connector out of the Right Ink Supply Station.

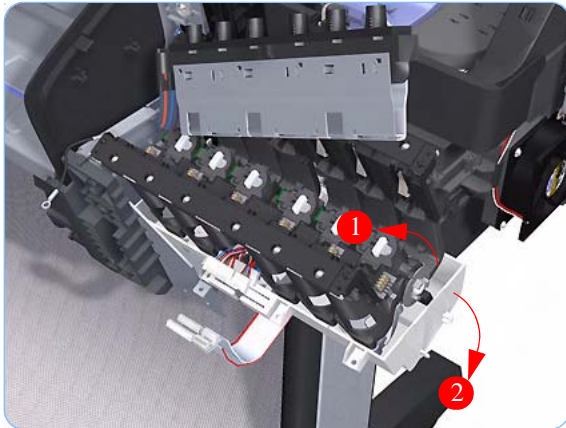

- 12.** Carefully lift the Right Ink Supply Station enough so that you can rotate it clockwise to release the front attachment from the printer.

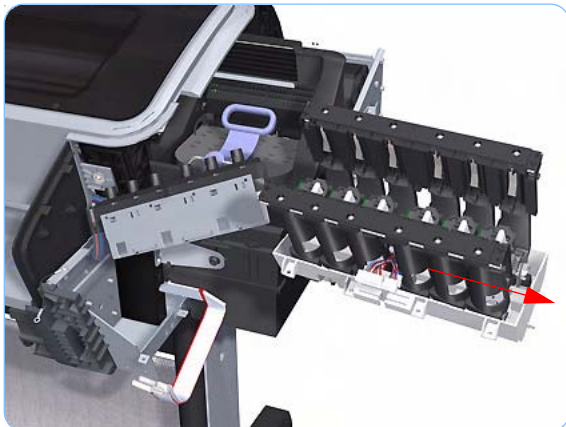

- 13.** Carefully lift the Right Ink Supply Station completely out of the printer.

Left Ink Supply Station

Removal

Switch off the printer and remove the power cable.

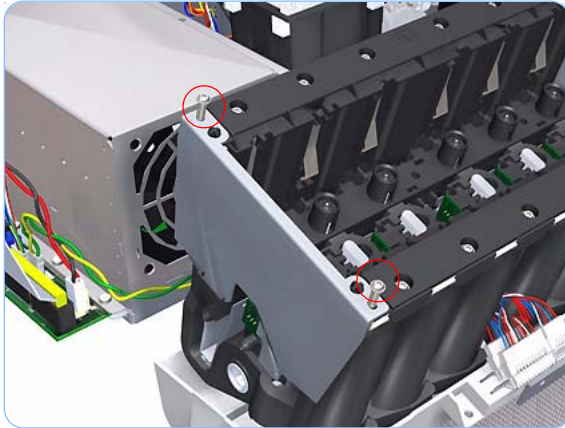

1. Remove the Left Cover (refer to page 8-21).
2. Remove two T-10 screws that secure the Left Side Plate of the Left Ink Supply Station.

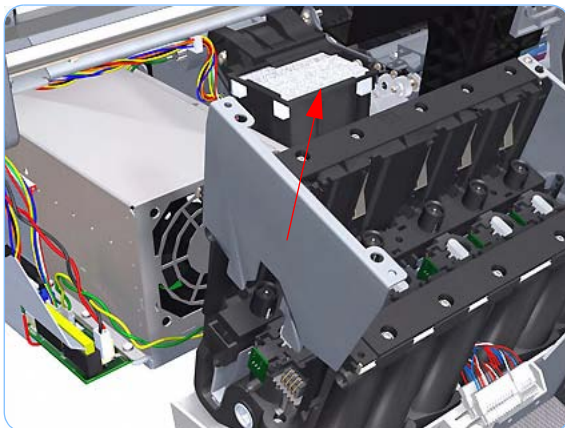

3. Remove the Left Side Plates of the Left Ink Supply Station.

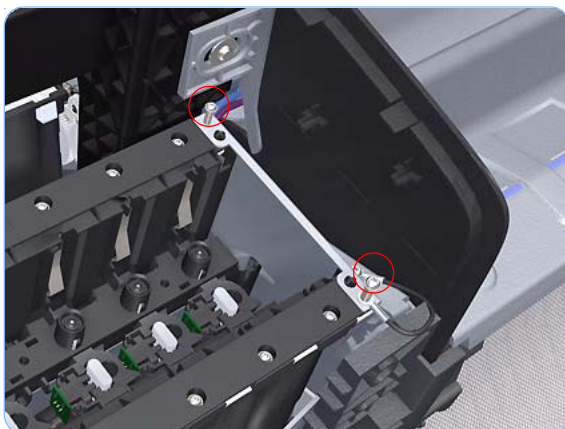

4. Remove two T-10 screws that secure the Right Side Plate of the Left Ink Supply Station.

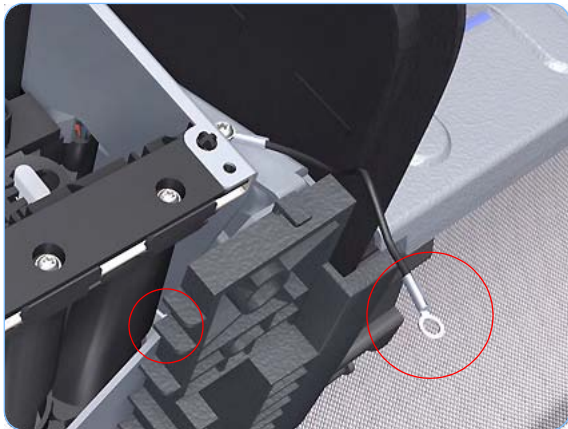

5. Remove the Left Ink Supply Station bonding cable.

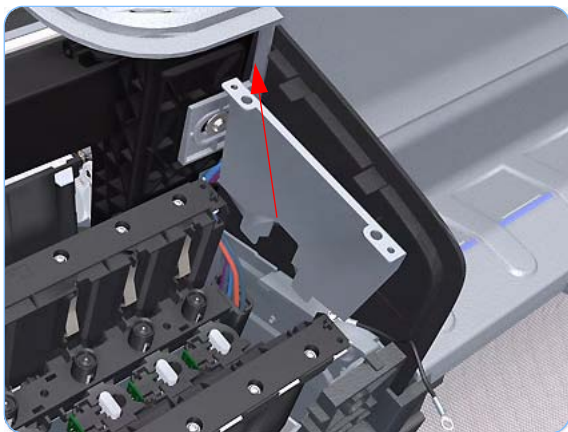

6. Remove the Right Side Plate of the Left Ink Supply Station.

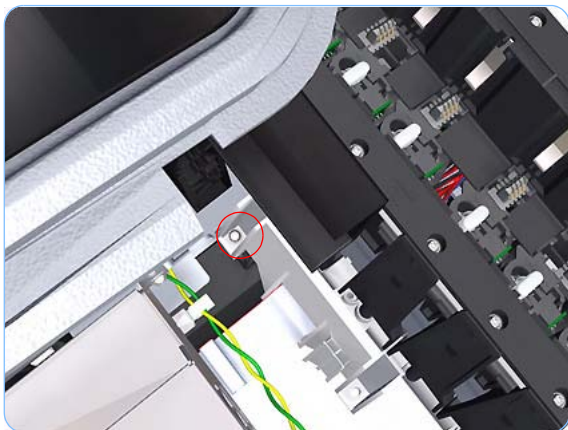

7. Remove the T-15 screw that secures the Left Ink Supply Station to the printer.

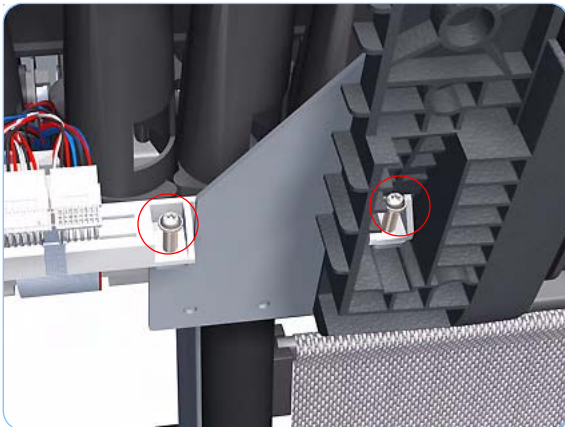

- 8.** Remove the two T-15 screws that secure the Left Ink Supply Station to the printer.

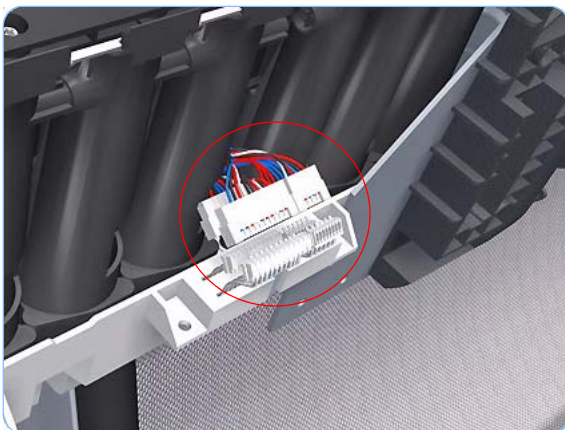

- 9.** Disconnect the three connectors from the Left Ink Supply Station.

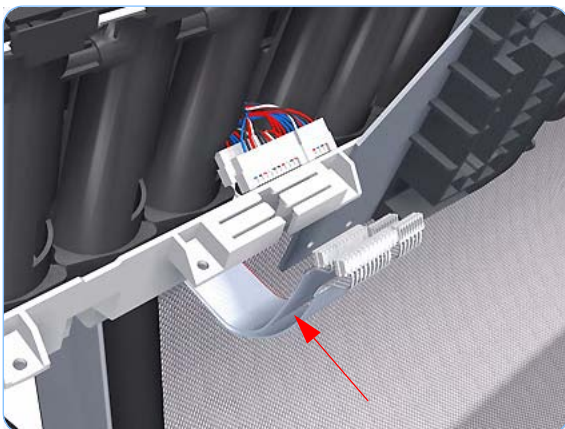

- 10.** Unroute the three cables from the Left Ink Supply Station.

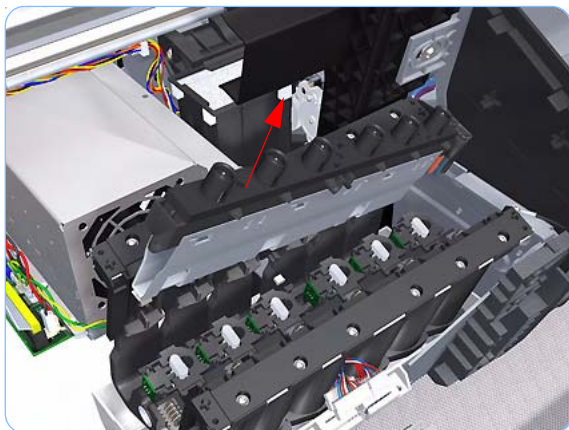

11. Carefully lift the Cartridge Tubes Connector out of the Left Ink Supply Station.

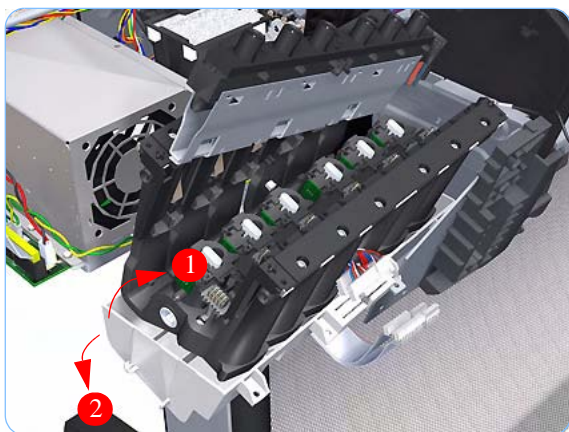

12. Carefully lift the Left Ink Supply Station enough so that you can rotate it counterclockwise to release the front attachment from the printer.

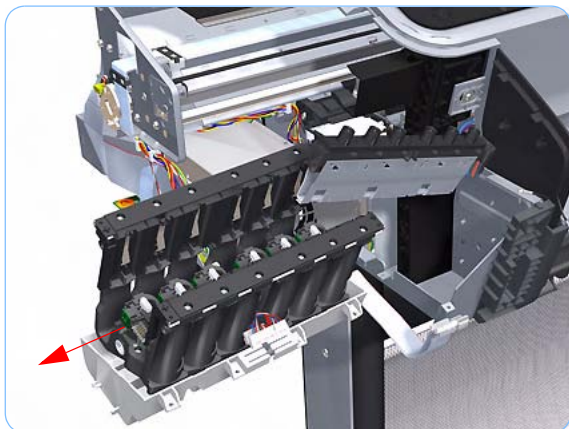

13. Carefully lift the Left Ink Supply Station completely out of the printer.

Ink Supply Tubes

Removal

Switch off the printer and remove the power cable.

1. Remove the Right Cover (refer to page 8-18).
2. Remove the Left Cover (refer to page 8-21).
3. Remove the Front Panel (refer to page 8-40).
4. Remove the Top Cover (refer to page 8-42).
5. Open the Carriage Cover.
The illustration shows the Z2100 which only has four Printheads, for the Z3100 there are six Printheads.

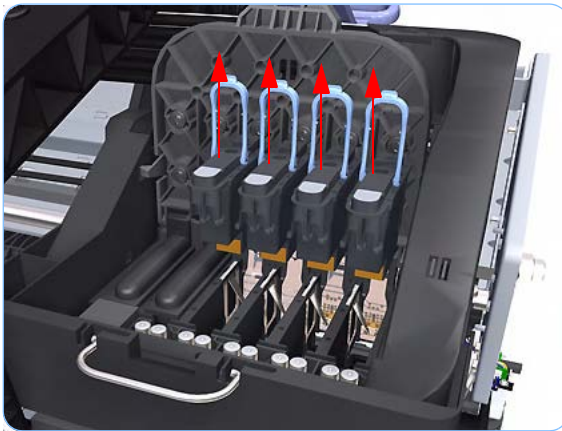
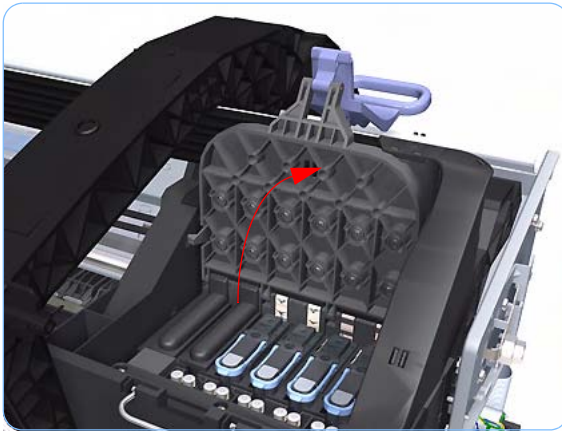

6. Remove all the Printheads.

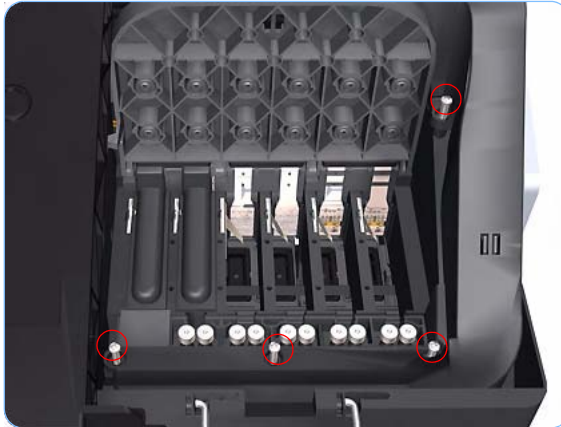

- 7.** Remove the four T-15 screws that secure the Ink Supply Tubes to the Carriage Assembly.

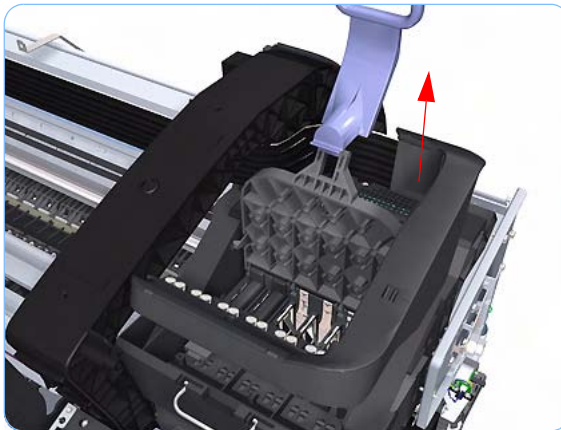

- 8.** Carefully lift out the Ink Supply Tubes.



- 9.** Close and lock the Carriage Assembly cover.



10. Carefully feed the Ink Supply Tubes into the print path area.



11. Remove the top T-15 screw that secures Ink Supply Tubes guide to the printer.

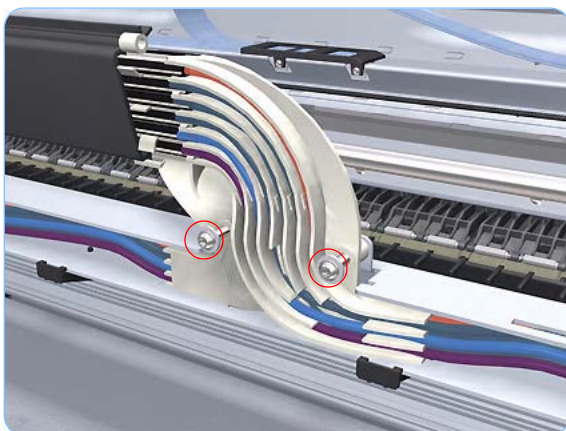

12. Remove the front T-15 screws that secure Ink Supply Tubes guide to the printer.

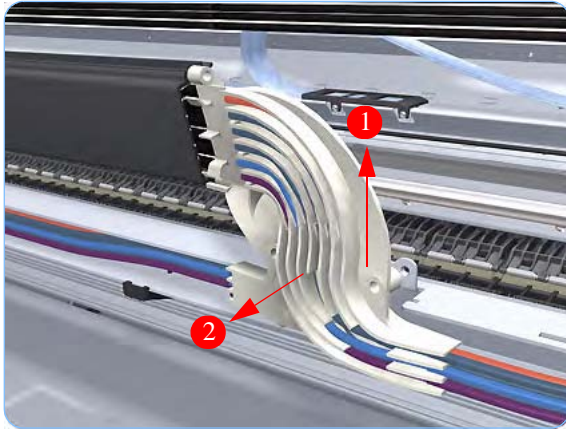

13. Carefully lift the Ink Supply Tubes guide enough until you can slide it forwards out of the printer.



14. Use a flat bladed screwdriver to release all the Ink Supply Tubes clamps from the printer.

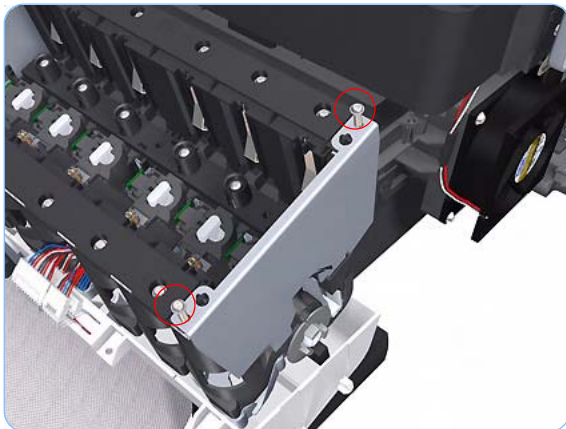

15. Remove two T-10 screws that secure the right Side Plate of the Right Ink Supply Station.

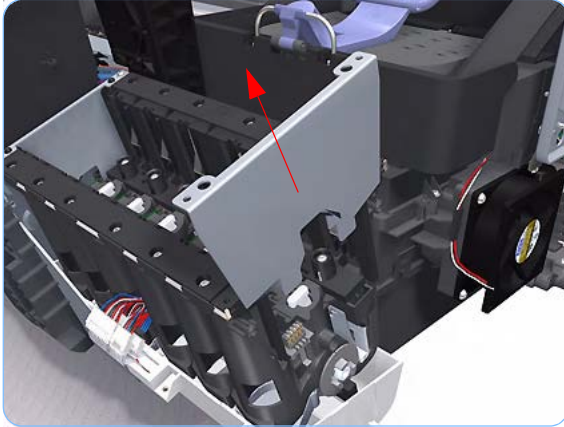

16. Remove the Right Side Plate of the Right Ink Supply Station.

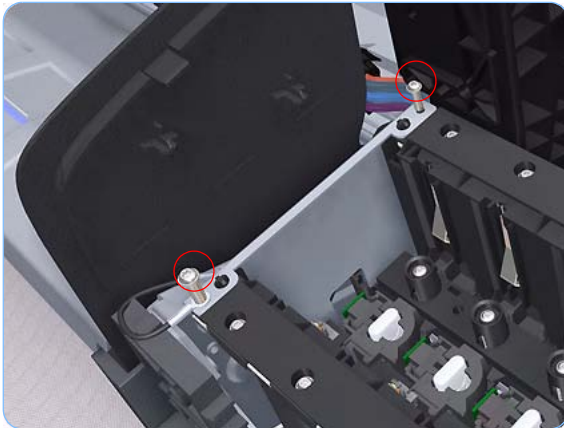

17. Remove two T-10 screws that secure the left Side Plate of the Right Ink Supply Station.

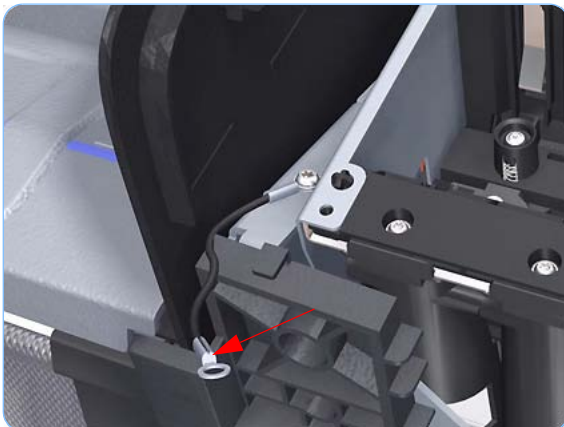

18. Remove the Right Ink Supply Station bonding cable.

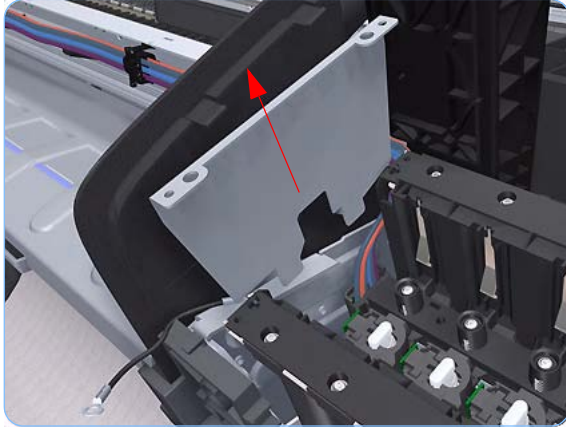

19. Remove the left Side Plate of the Right Ink Supply Station.

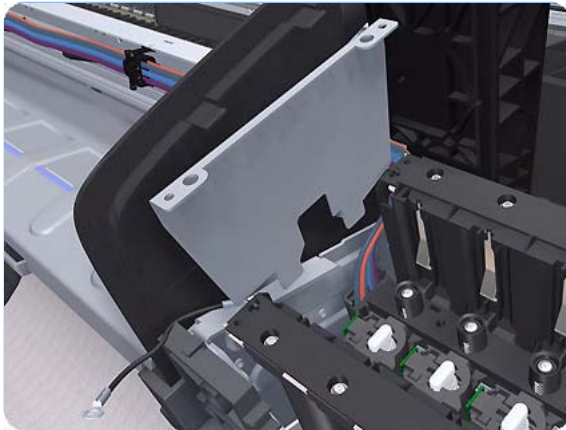

20. Carefully lift the Cartridge Tubes Connector out of the Right Ink Supply Station.

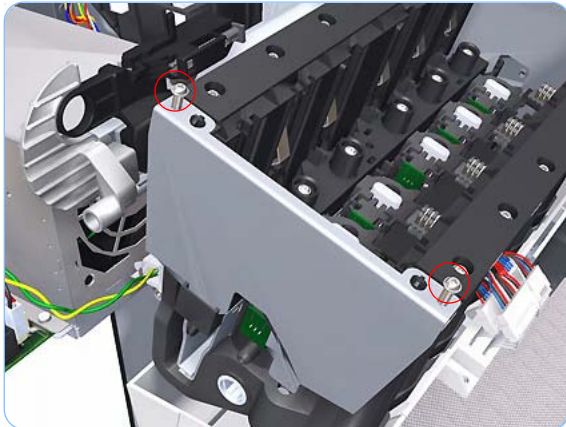

21. Remove two T-10 screws that secure the left Side Plate of the Left Ink Supply Station.

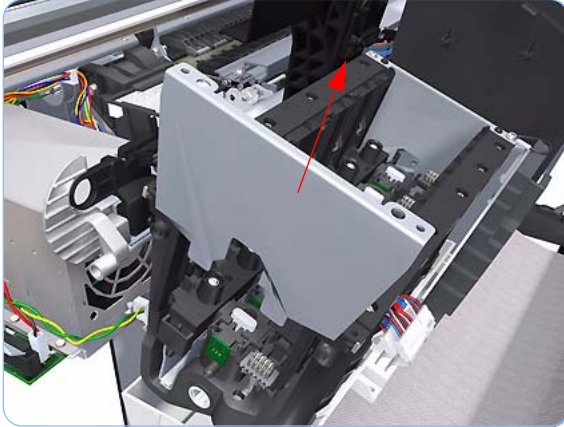

22. Remove the left Side Plate of the Left Ink Supply Station.

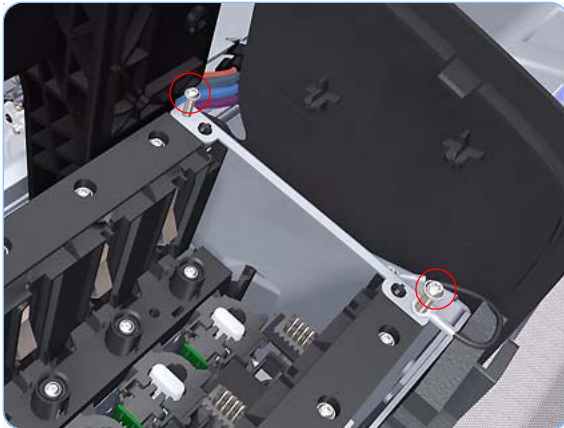

23. Remove two T-10 screws that secure the right Side Plate of the Left Ink Supply Station.

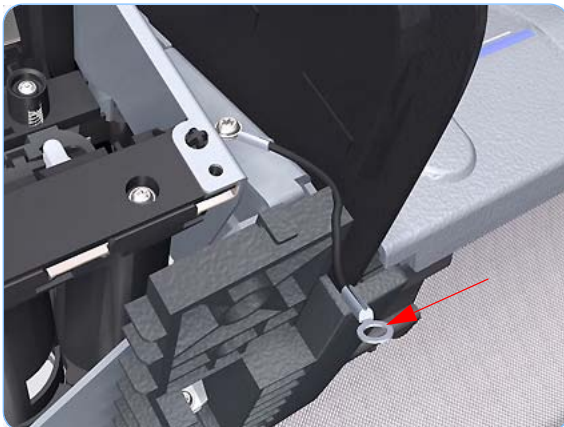

24. Remove the Left Ink Supply Station bonding cable.

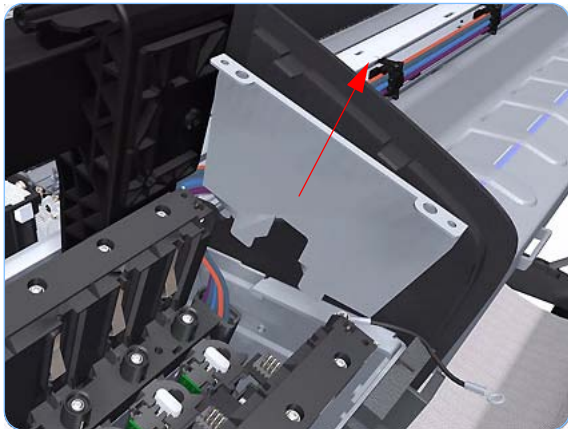

25. Remove the right Side Plate of the Left Ink Supply Station.



26. Carefully lift the Ink Supply Tubes out of the printer.

Formatter

Removal

Switch off the printer and remove the power cable.



1. Fully loosen the two locking thumbscrews that secure the Formatter in the printer.

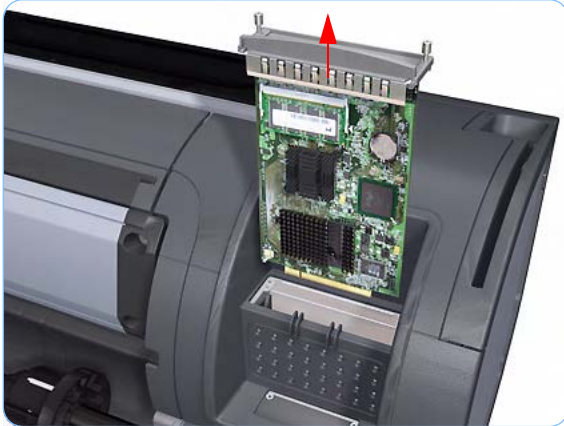

2. Lift the Formatter out of the printer.

When you install a new formatter follow the instructions provided on the Flyer that accompanies it to set up the printer.

Electronics Module (Main PCA and PSU)

Removal

Switch off the printer and remove the power cable.

1. Remove the Left Cover (refer to page 8-21).
2. Disconnect all the connectors on the Electronics Module.

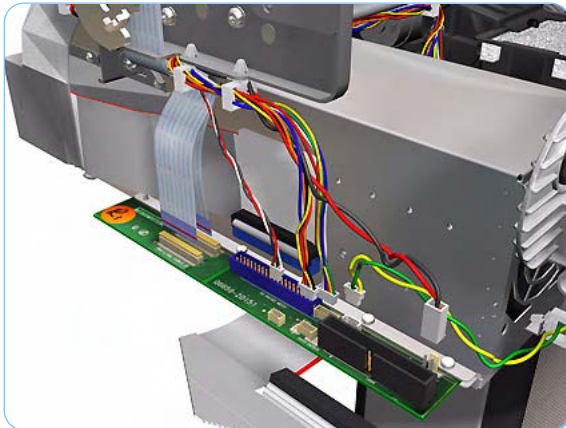

3. Unroute all the cables disconnected in the previous step.

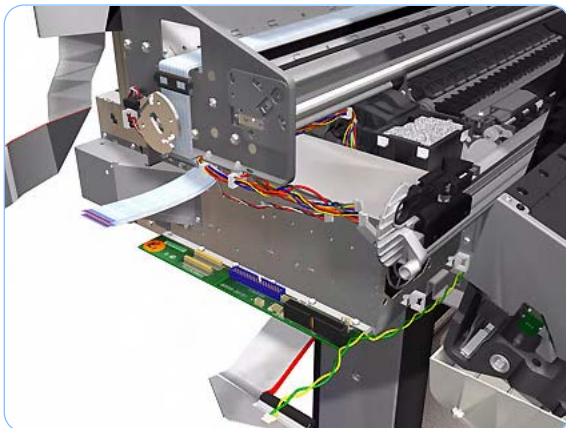

4. Remove two T-15 screws that secure the Electronics Module to the Printer.

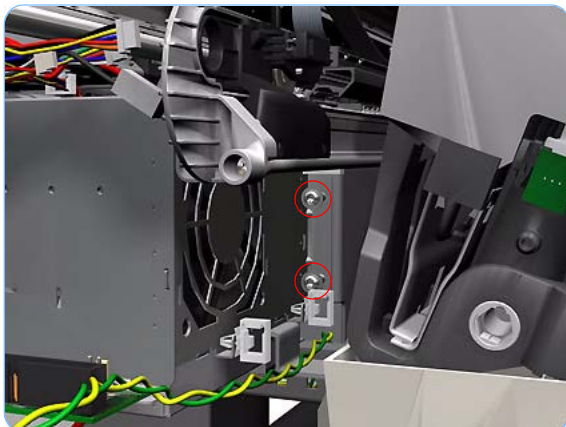

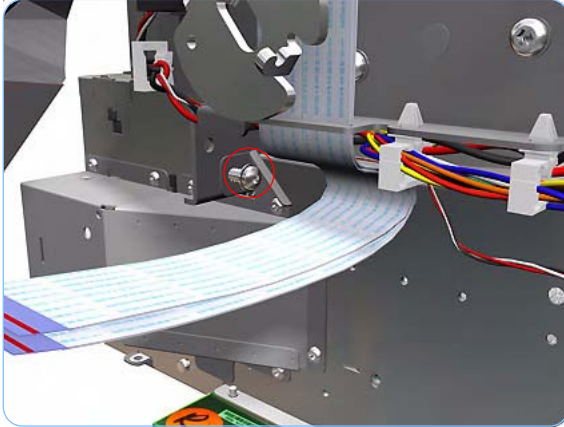

- 5.** Remove one T-15 screw that secures the Electronics Module to the Printer.

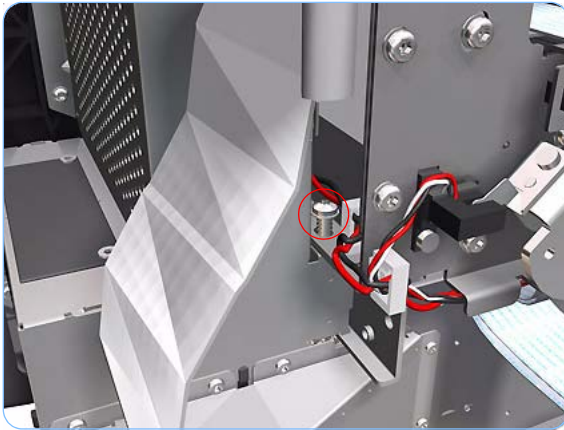

- 6.** Remove one T-15 screw that secures the Electronics Module to the Printer.

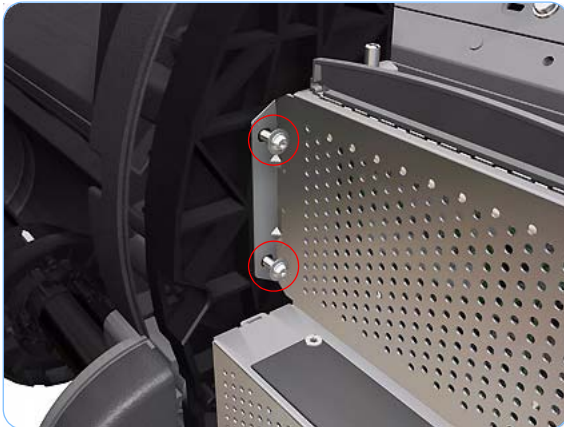

- 7.** Remove two T-15 screws that secure the Electronics Module to the Printer.



8. Remove one T-15 screw that secures the Electronics Module to the printer.



9. Carefully lift the Electronics Module out of the printer.

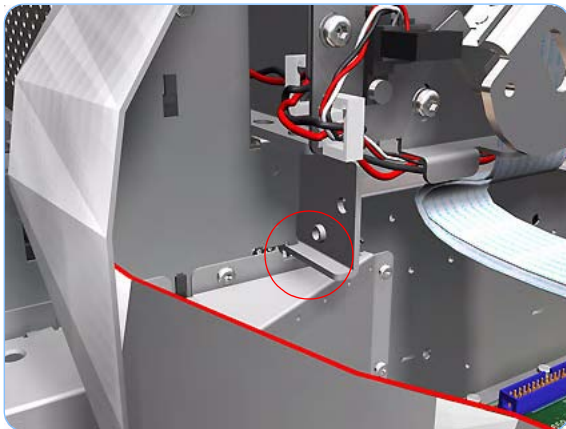

When you install the Electronics Module make sure it is correctly aligned with the mounting rail.

Starwheel Assembly

Removal

Switch off the printer and remove the power cable.



1. Open the Window.

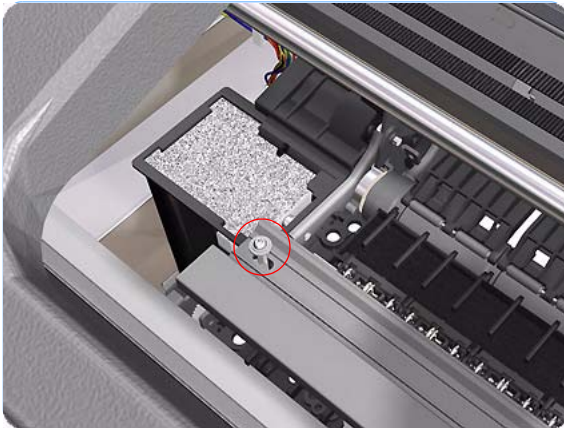

2. Remove one T-15 screw that secures the Starwheel Assembly to the Printer.

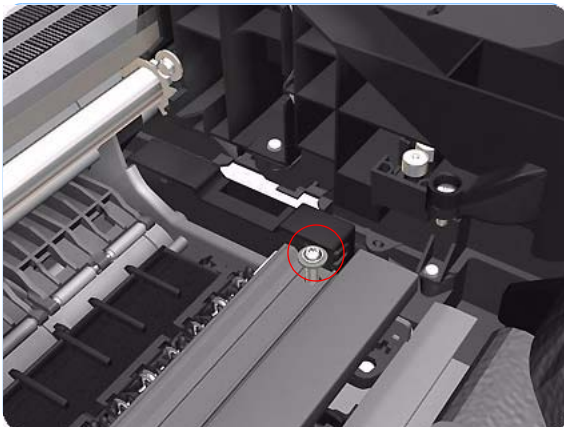

3. Remove one T-15 screw that secures the Starwheel Assembly to the Printer.

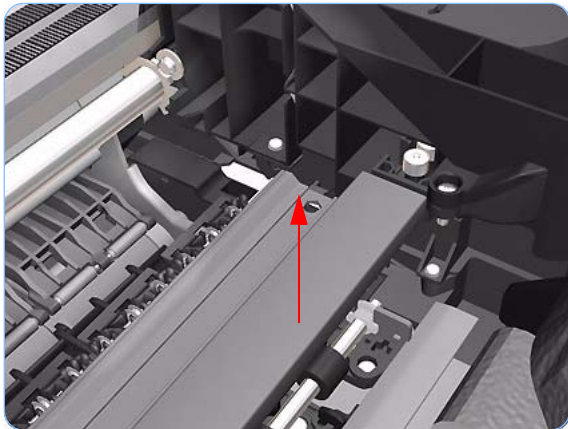

4. Carefully lift the Starwheel Assembly out of the printer.

Print Zone Overdrive

Removal

Switch off the printer and remove the power cable.

1. Remove the Starwheel Assembly (refer to page 8-144).

The Print Zone Overdrive is in two sections (left and right). This procedure describes the removal of both of the sections. If you only want to remove one of the sections skip the steps for the other section.

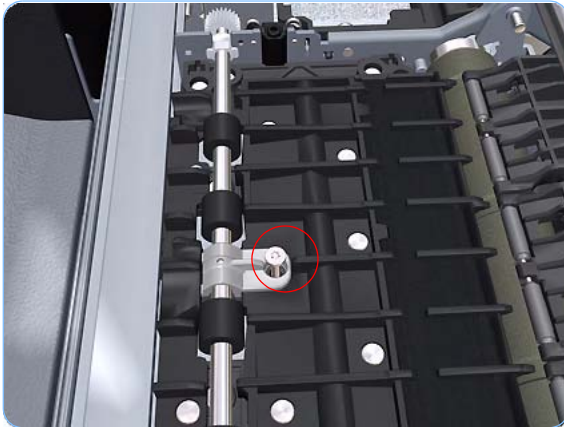

2. Remove one T-15 screw that secures the left clamp of the Print Zone Overdrive to the Platen.

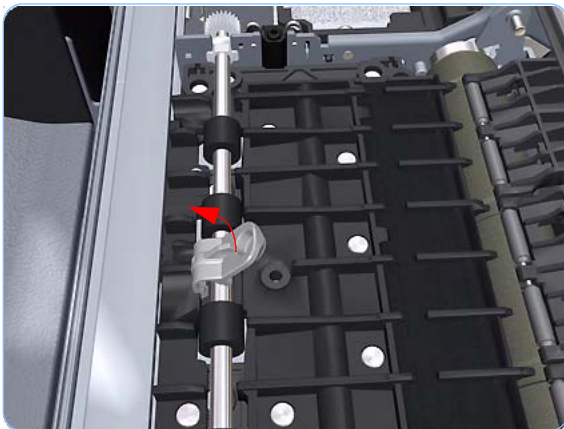

3. Lift attachment clamp vertically to release it from the Platen.

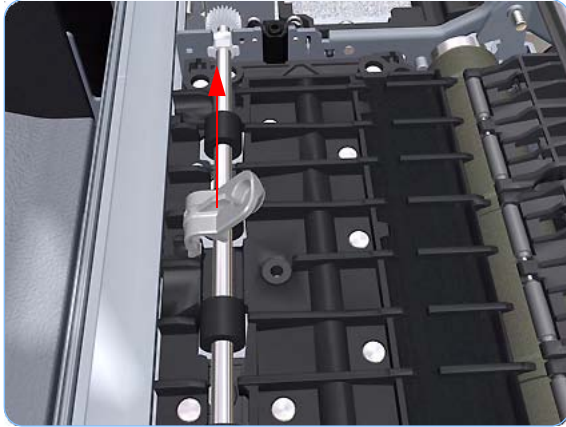

4. Remove the clamp.



5. Repeat steps 2 to 4 to remove the remaining five attachment clamps.

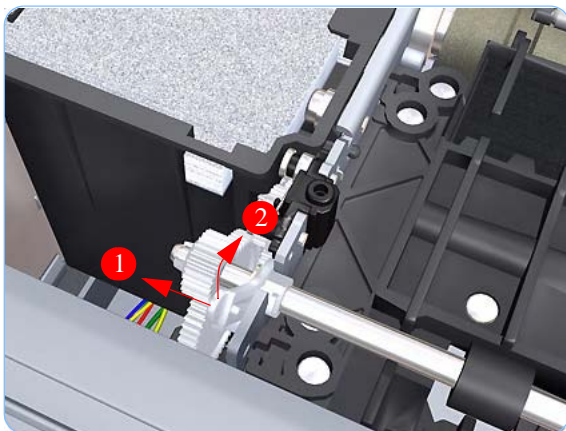

6. Use a flat bladed screwdriver to unclip the left Print Zone Overdrive retaining clip and rotate the clip vertically.

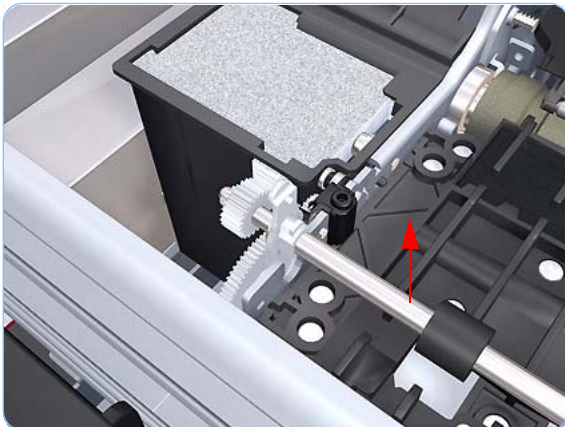

7. Carefully lift the left Print Zone Overdrive enough (10 mm) so you can slide it to the left.

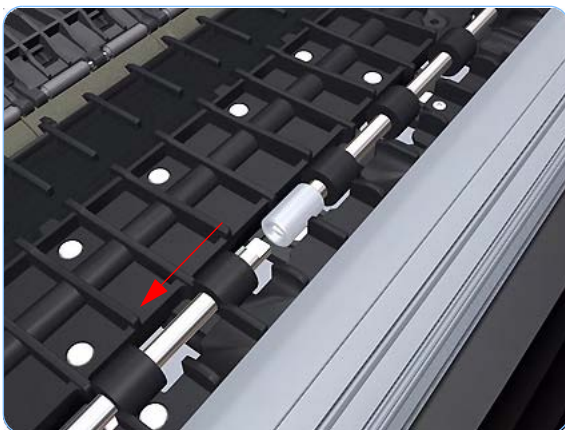

8. Slide the left Print Zone Overdrive to the left to disengage the center coupling.

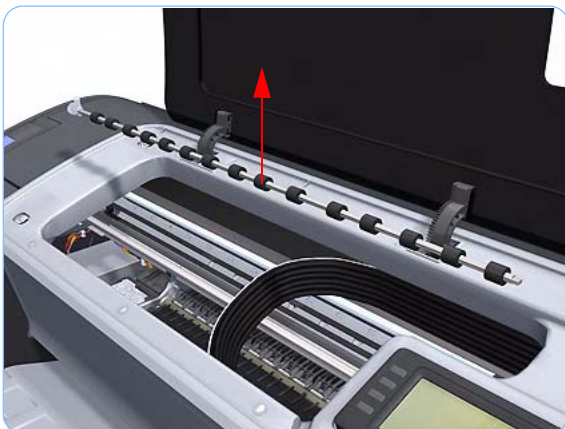

9. Carefully lift the left Print Zone Overdrive out of the printer.

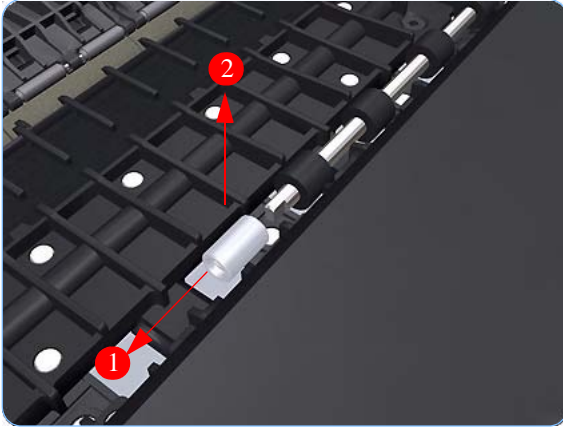

10. Remove the center coupling.

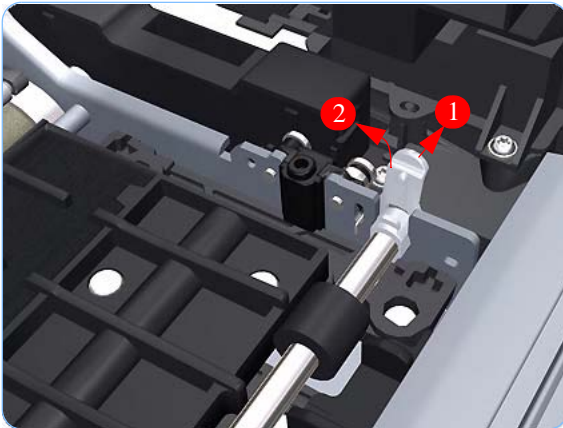

11. Use a flat bladed screwdriver to unclip the left Print Zone Overdrive retaining clip and rotate the clip vertically.

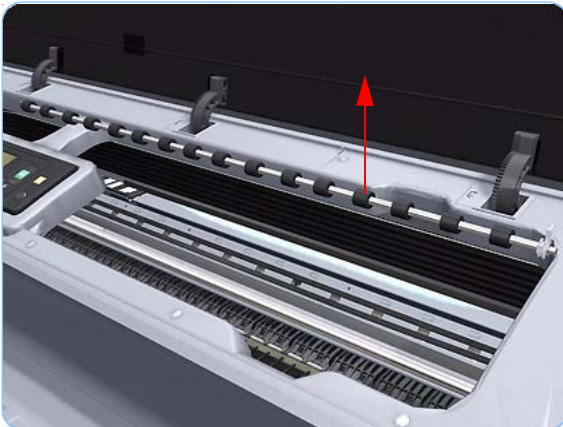

12. Carefully lift the right Print Zone Overdrive out of the printer.

Left Spittoon

Removal

This procedure describes how to remove the complete Left Spittoon which is necessary to gain access to other components. If you only need to replace the Foams of the Left Spittoon, use the protective gloves and the tweezers (provided in the Tool Kit) to remove them with it in place.

Switch off the printer and remove the power cable.

1. Remove the Left Cover (refer to page 8-21).
2. Remove the Electronics Module (Main PCA and PSU) (refer to page 8-141).
3. Remove two T-8 screws that secure the Left Spittoon to the printer.

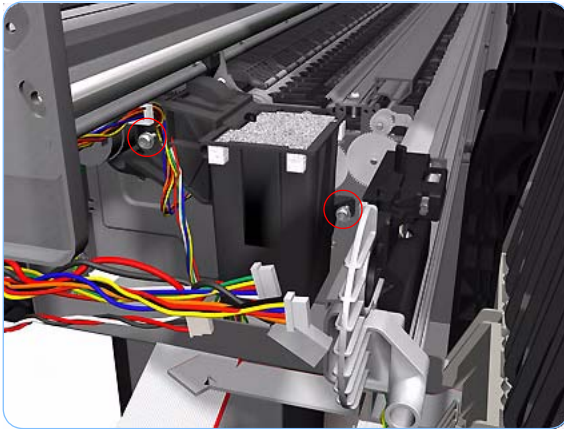

4. Use protective gloves and remove the top segment of foam from the Left Spittoon (to gain access to the last attachment screw).

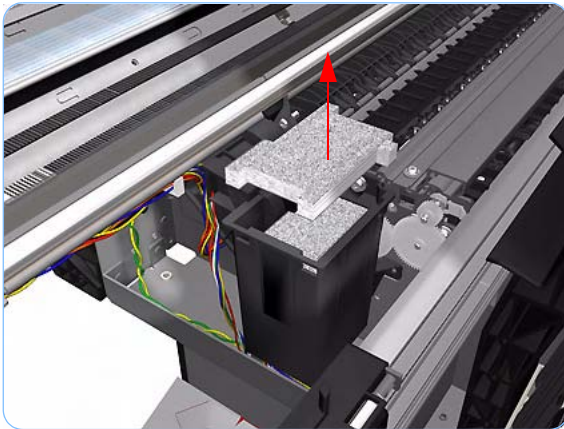

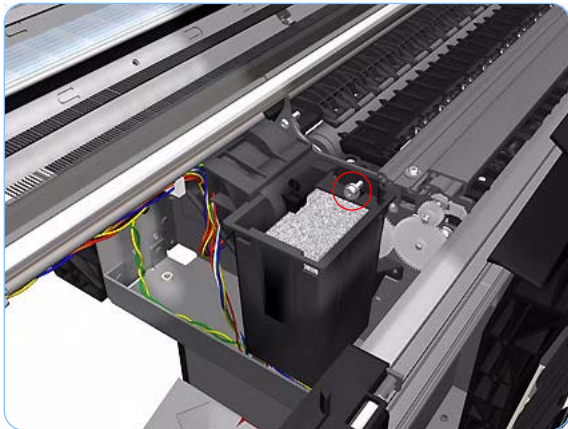

5. Remove one T-15 screw that secures the Left Spittoon to the printer.

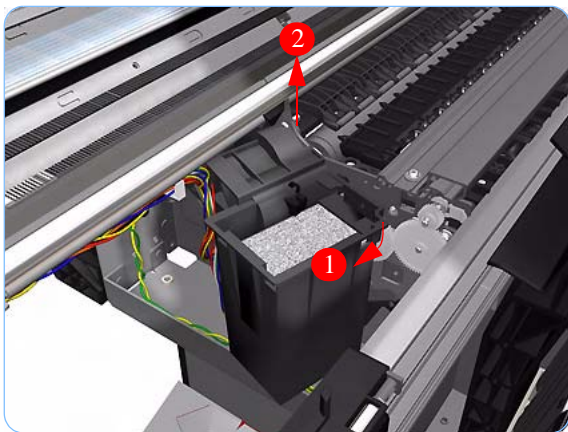

6. Rotate the Left Spittoon clockwise approximately 45 degrees and carefully lift it out of the printer.

Encoder Disk and Encoder Sensor

Removal

Switch off the printer and remove the power cable.

1. Remove the Left Cover (refer to page 8-21).
2. Remove the Electronics Module (Main PCA and PSU) (refer to page 8-141).
3. Remove the Left Spittoon (refer to page 8-150).
4. Remove and discard the Encoder Disk from the end of the Media Advance Roller spindle.

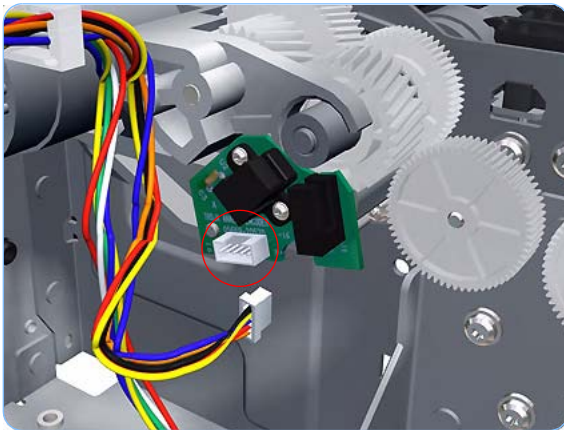
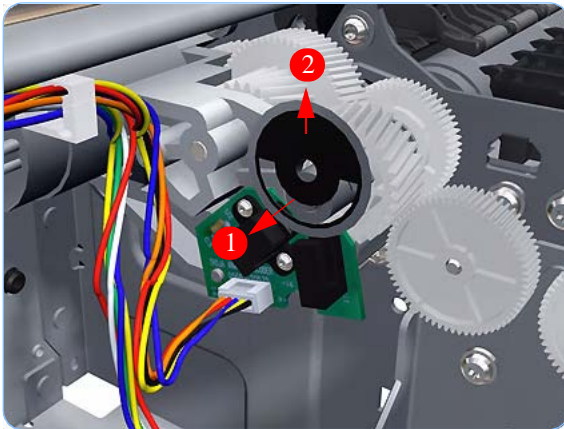

5. Disconnect the Encoder Sensor connector.

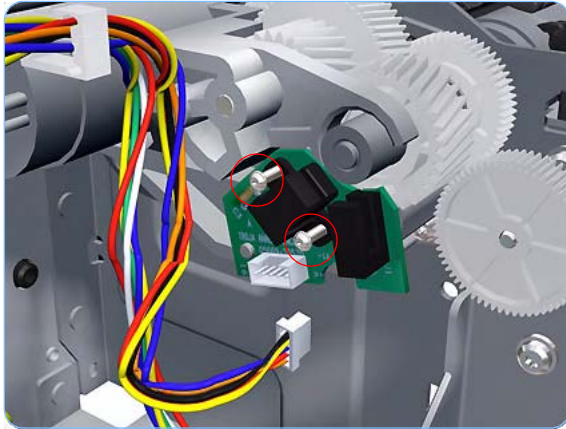

6. Remove two T-8 screws that secure the Encoder Sensor to the Media Advance Drive.

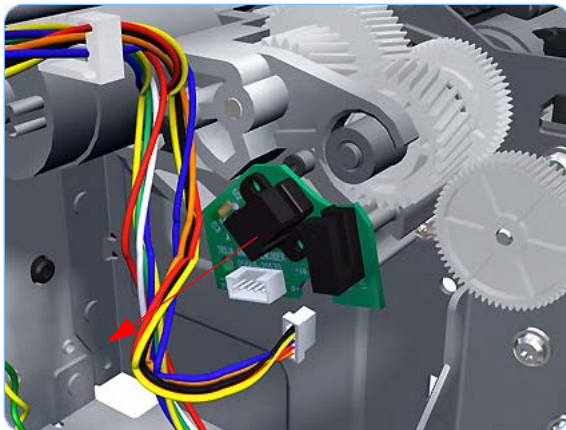

7. Remove the Encoder Sensor PCA from the printer.

Installation

If you are installing the Encoder Sensor after replacing the Media Advance Drive with a new unit, you will need to adjust the Encoder Sensor position on the Media Advance Drive. To do this you will need Media Advance Drive Adjustment Tool from the HP Designjet Z2100/Z3100 Printer Tool Kit (Q6683-67001).

You will also need to execute the Paper Drive calibration to ensure that the Analog Encoder Channel A and B Gain Values are within tolerance (a Gain value of 3 or less).

1. If you are installing the Encoder Sensor after replacing the Media Advance Drive with a new unit, first fully loosen the Encoder Sensor position adjustment screw. Ignore this step if you are replacing the previously removed Media Advance Drive.

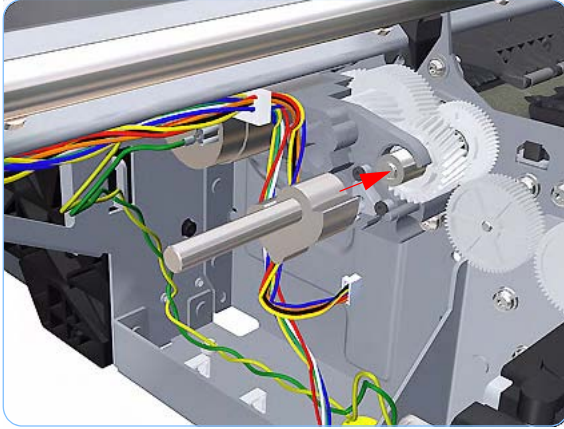

2. Position the Media Advance Drive Adjustment Tool on the end Media Advance Roller shaft, push it firmly onto the shaft and maintain a constant pressure to ensure it is flush to the Media Advance Drive.

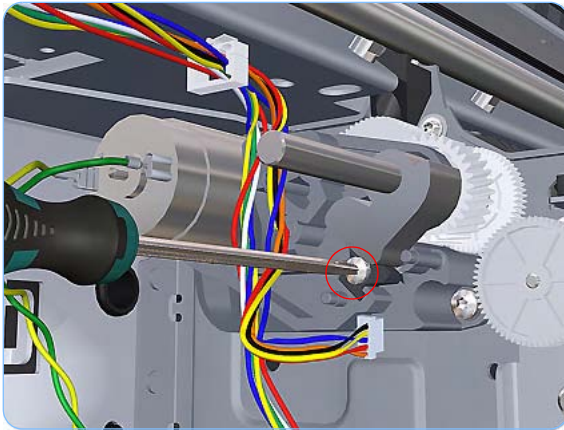

3. While still maintaining pressure on the Media Advance Drive Adjustment Tool, fully tighten the Encoder Sensor position adjustment screw.

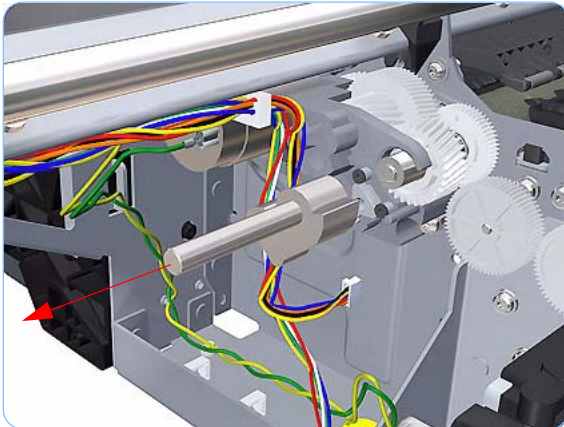

4. Remove the Media Advance Drive Adjustment Tool.

5. Complete the installation of the Encoder Sensor and a new Encoder Disk.

6. Calibrate the Paper Drive (see page 4-16).

Media Advance Drive

Removal

Switch off the printer and remove the power cable.

1. Remove the Left Cover (refer to page 8-21).
2. Remove the Electronics Module (Main PCA and PSU) (refer to page 8-141).
3. Remove the Left Spittoon (refer to page 8-150).
4. Remove the Encoder Disk and Encoder Sensor (refer to page 8-152).
5. Unroute the Media Advance Drive power cable.

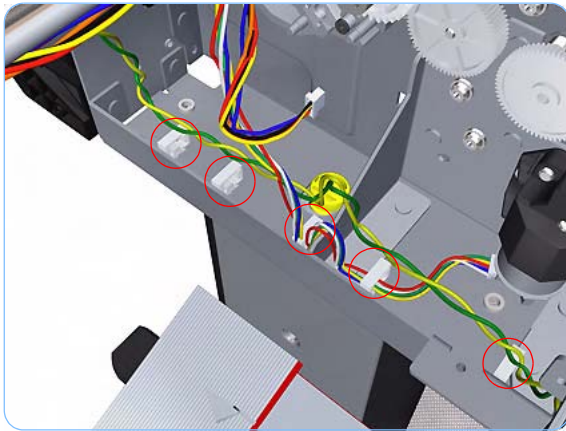

6. Remove three T-15 screws that secure the Media Advance Drive to the printer.

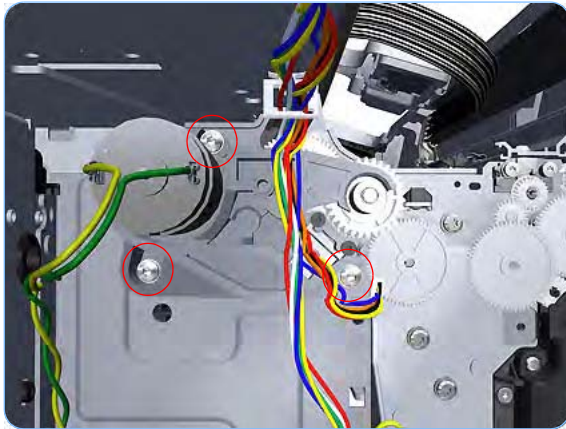

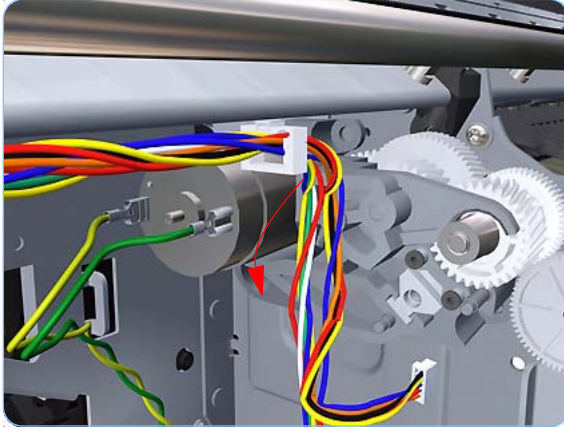

7. Grip the motor housing of the Media Advance Drive and gently pull it towards you sufficiently to allow you disengage the Media Advance Drive from printer.

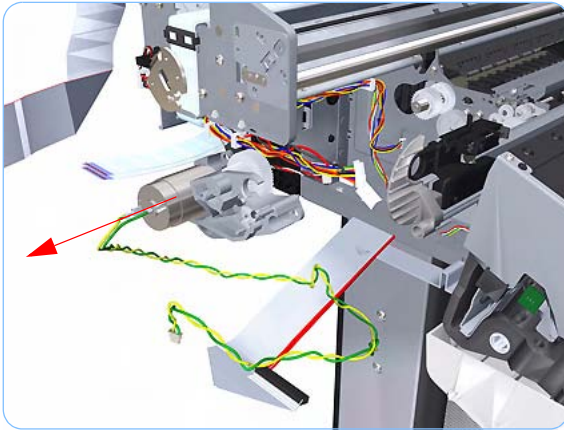

8. Carefully lift the Media Advance Drive out of the printer.

Installation

Use the following procedure to install and correctly adjust a new Media Advance Drive. You will need Media Advance Drive Adjustment Tool from the HP Designjet Z2100/Z3100 Printer Tool Kit (Q6683-67001). If you are installing the Encoder Sensor after replacing the Media Advance Drive with a new unit, you will need to adjust the Encoder Sensor position on the Media Advance Drive (refer to page 8-155).

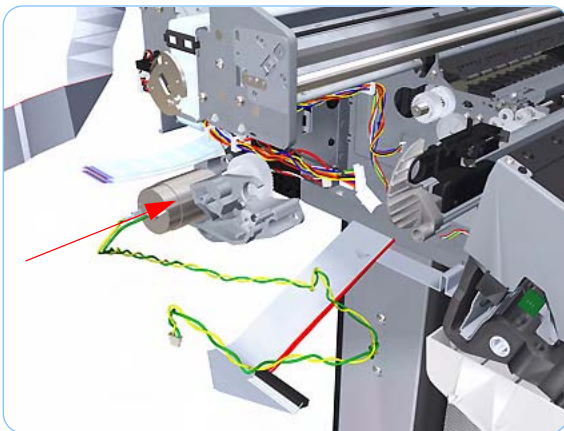

1. Carefully position the Media Advance Drive in the printer.

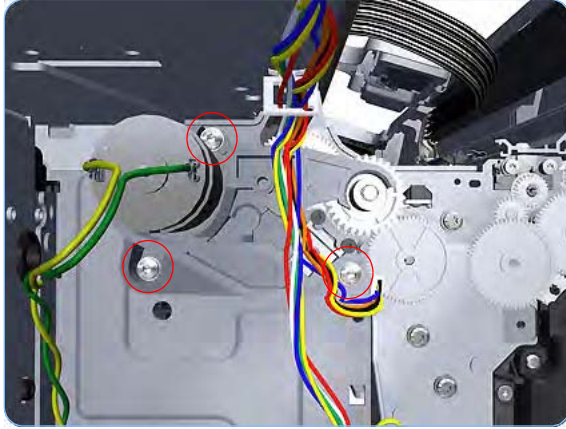

2. Insert the three T-15 attachment screws but do NOT fully tighten them.

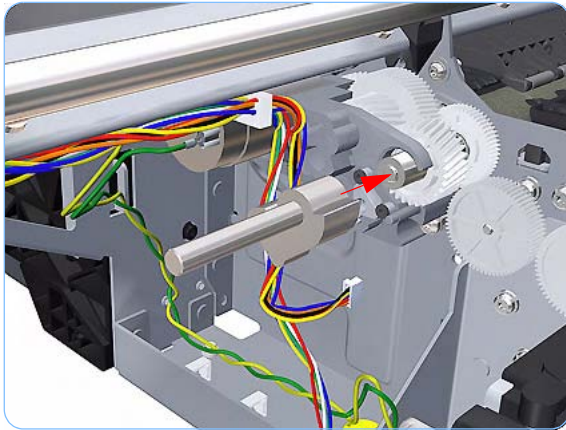

3. Position the Media Advance Drive Adjustment Tool on the end Media Advance Roller shaft, push it firmly onto the shaft and maintain a constant pressure to ensure it is flush to the Media Advance Drive.

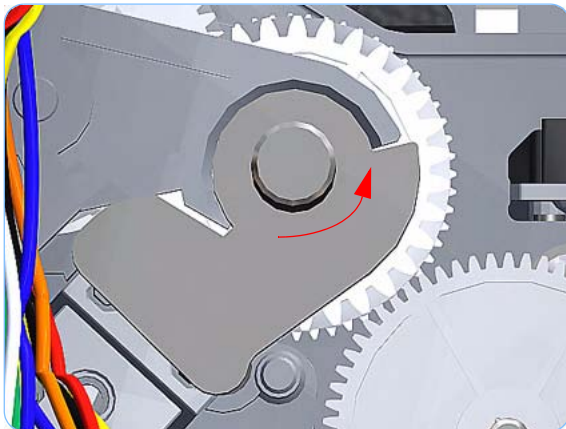

4. Rotate the Media Advance Drive Adjustment Tool fully counter-clockwise to ensure its flat surface of the tool is firmly against the flat surface of the Media Advance Drive mounting.

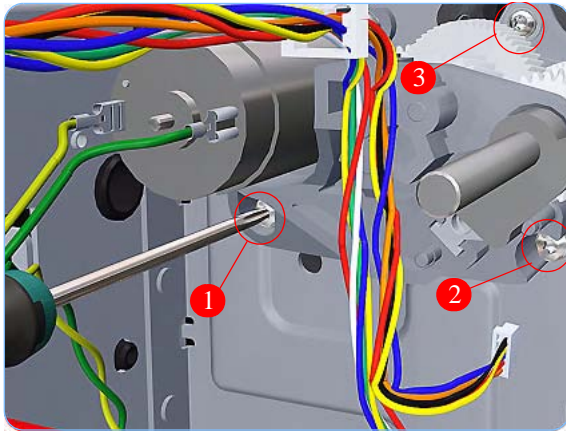

5. While maintaining pressure on the Media Advance Drive Adjustment Tool, fully tighten the three T-15 attachment screws in the order shown.

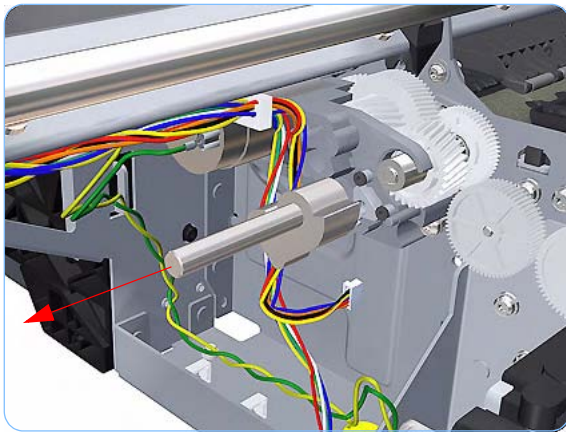

6. Remove the Media Advance Drive Adjustment Tool.

Media Advance Roller

Removal

Switch off the printer and remove the power cable.

1. Remove the Left Cover (refer to page 8-21).
2. Remove the Clean Out Assembly (refer to page 8-68).
3. Remove the Electronics Module (Main PCA and PSU) (refer to page 8-141).
4. Remove the Left Spittoon (refer to page 8-150).
5. Remove the Media Advance Drive (refer to page 8-155).
6. Remove the Media Advance Roller drive gear wheel to gain access the locking plate attachment screw.

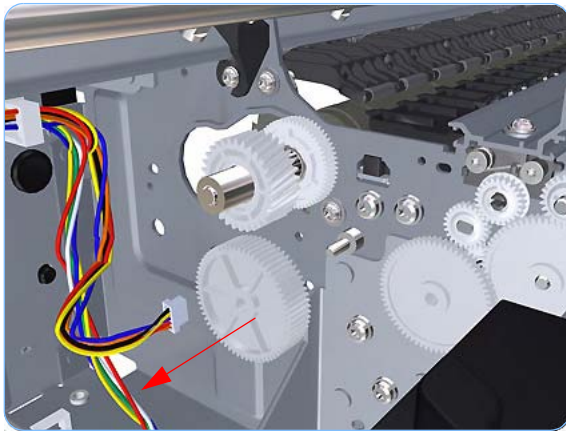

7. Remove two T-15 screws that secure the Media Advance Roller locking plate to the printer.

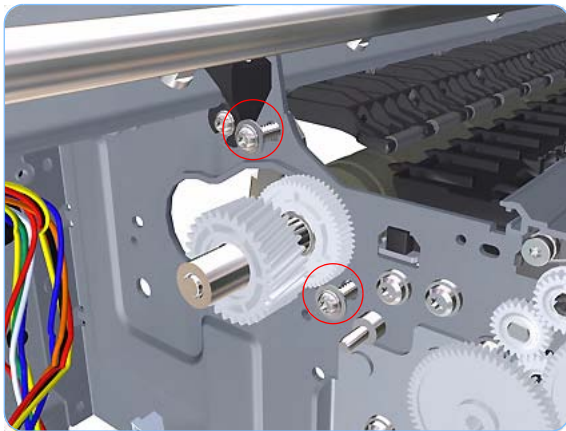

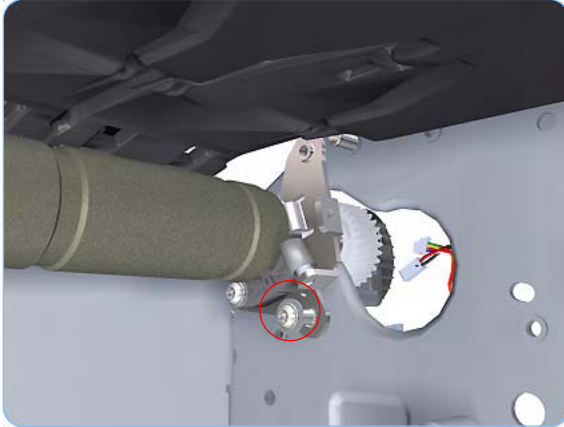

- 8.** Remove one T-15 screw that secures the Media Advance Roller locking plate to the printer.

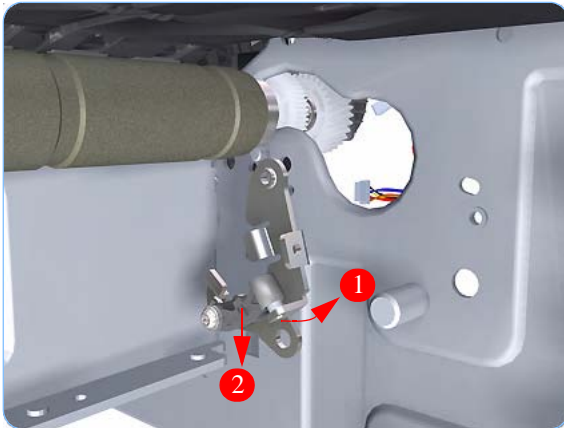

- 9.** Rotate the Media Advance Roller locking plate counterclockwise approximately 10 degrees and remove it from the printer (viewed from the rear of the printer).

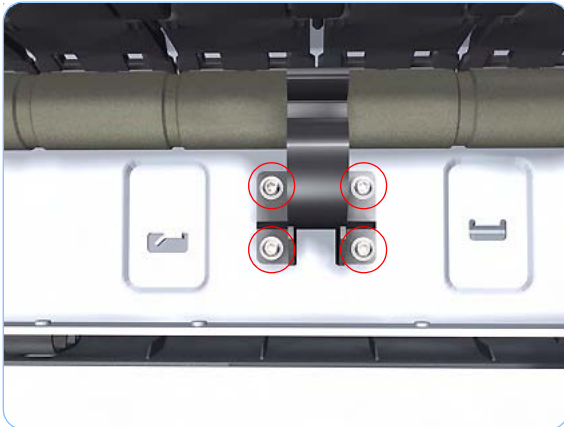

- 10.** Remove four T-15 screws that secure the Media Advance Roller right support to the printer.

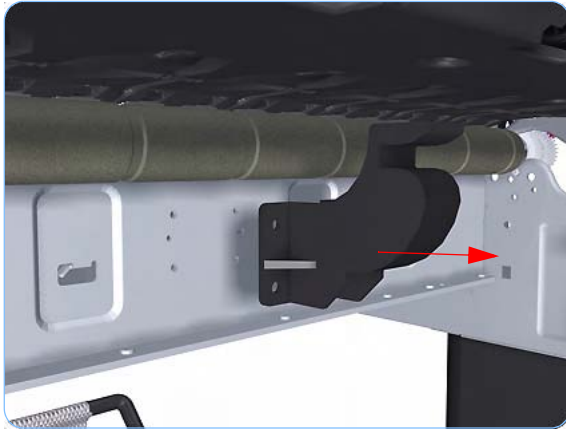

- 11.** Remove the Media Advance Roller right support from the printer.
- 12.** Repeat steps 12 and 13 for the Media Advance Roller left support.



- 13.** Remove two T-15 screws that secure the Media Advance Roller left locking plate (viewed from the rear of the printer).



- 14.** Remove the Media Advance Roller left locking plate (viewed from the rear of the printer).

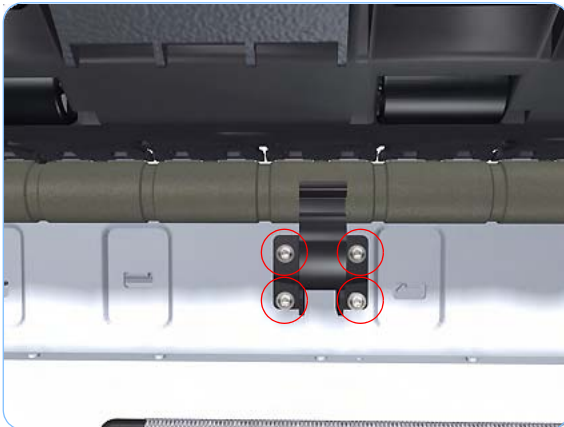

- 15.** Remove four T-15 screws that secure the Media Advance Roller left support to the printer.

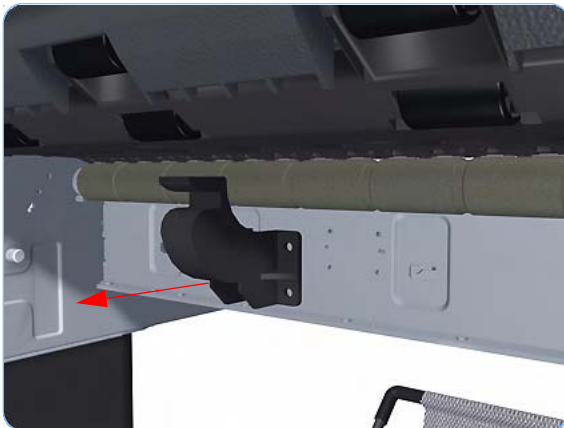

- 16.** Remove the Media Advance Roller left support from the printer.



- 17.** Remove one T-15 screw that secures the Media Advance Roller center support locking plate.

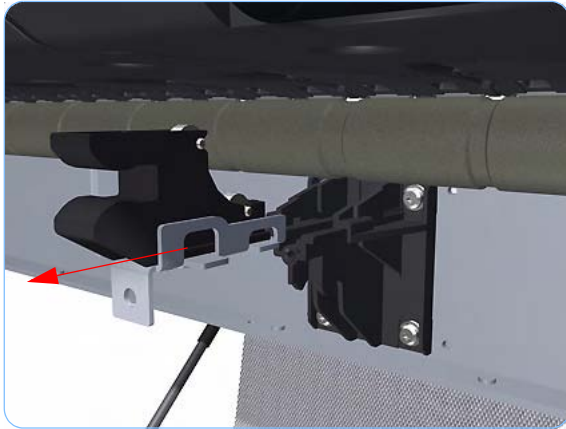

18. Remove the Media Advance Roller center support locking plate.

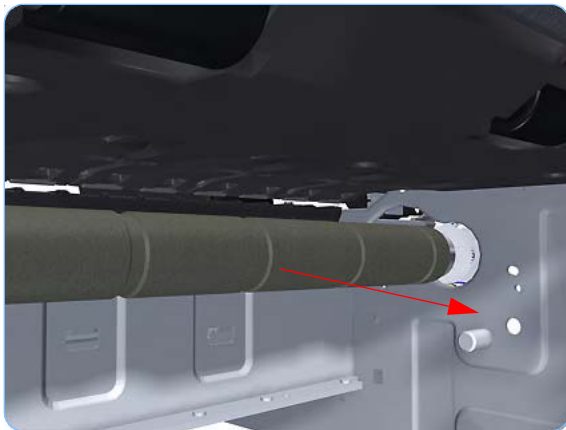

19. Pull the Media Advance Roller towards you.

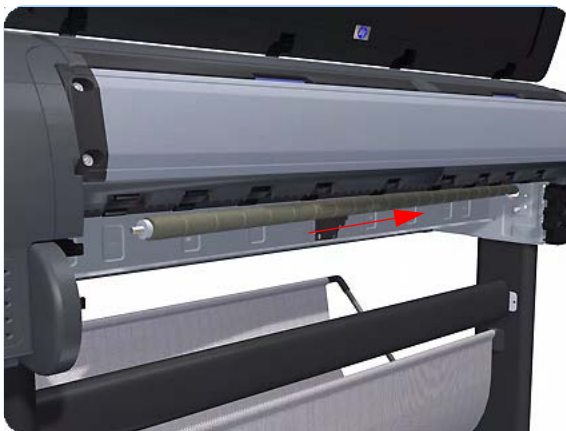

20. Slide the Media Advance Roller towards the right (viewed from the rear of the printer) until you can disengage the left end (viewed from the rear of the printer).

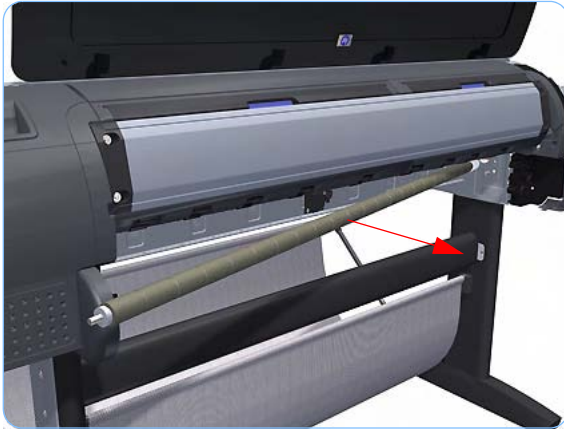

21. Remove the Media Advance Roller from the printer.

Pinchwheel Assembly

Removal

Switch off the printer and remove the power cable.

1. Remove the Window (refer to page 8-4).
2. Remove the Spindle (refer to page 8-65).
3. Remove the Left Roll Guide (refer to page 8-72).
4. Remove the Right Roll Guide (refer to page 8-73).
5. Raise the Media Lever.

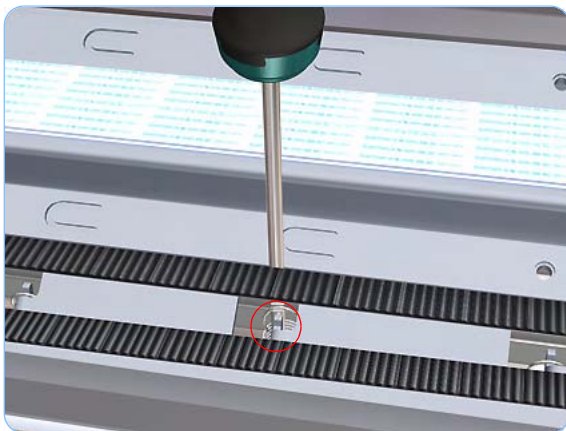
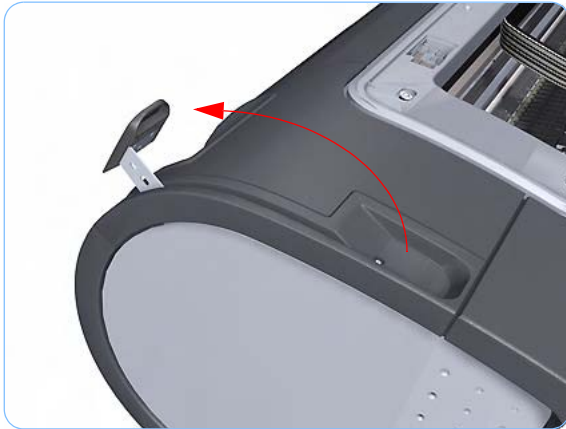

6. Use the Pinchwheel Insertion Tool to remove the spring from the attachment on the printer.

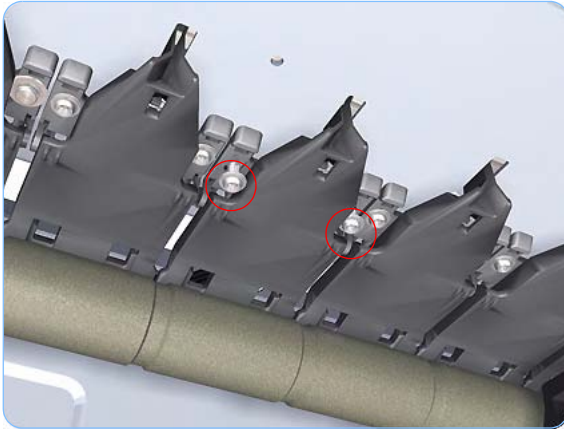

7. Remove two T-15 screws that secure the Pinchwheel Assembly to the printer.

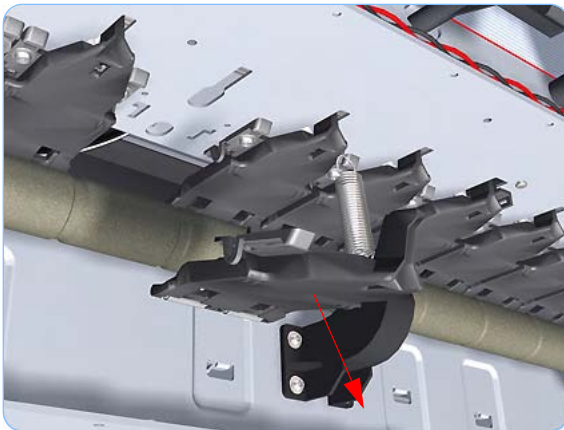

8. Remove the Pinchwheel Assembly from the printer.

Installation

Use the following procedure to align the Pinchwheel Assembly using the Pinchwheel Alignment Tool during reassembly



1. Insert the Pinchwheel Insertion Tool through the appropriate access hole for the Pinchwheel Assembly you are installing.

Be very careful not to damage the Encoder Strip or the Belt Assembly with the Pinchwheel Insertion Tool.

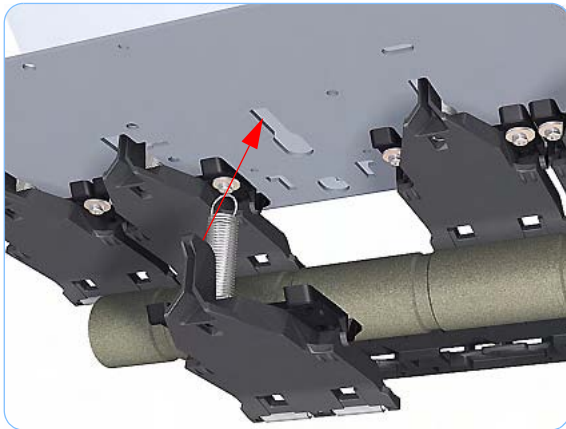

2. Position the new Pinchwheel Assembly correctly on its hanger.

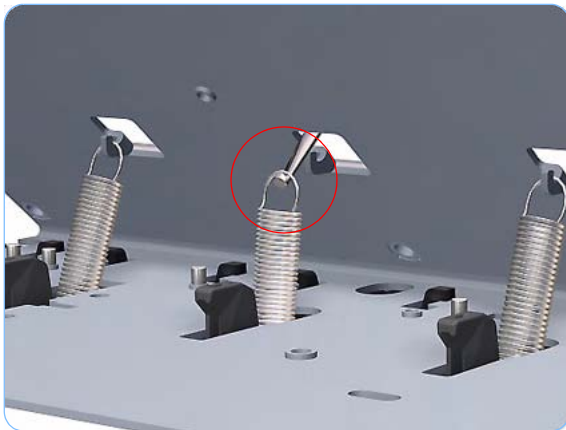

3. Hook the spring of the Pinchwheel Assembly you are installing with the Pinchwheel Insertion Tool.

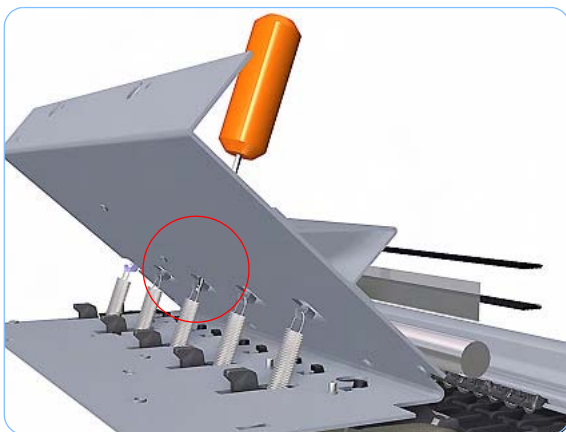

4. Attach the spring to its attachment point on the hanger and remove the Pinchwheel Insertion Tool.

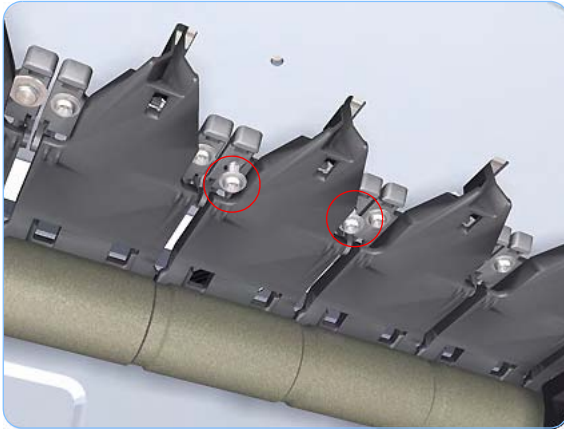

5. Attach the new Pinchwheel Assembly with the two T-15 screws that secure to the printer but do fully NOT tighten the screws.

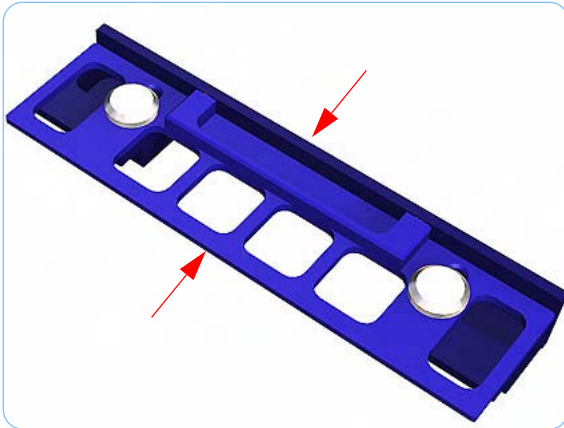

6. Compress the Pinchwheel Alignment Tool.



7. Position the Pinchwheel Alignment Tool on the platen so it is aligned with the two adjacent Pinchwheels to the one you are installing.

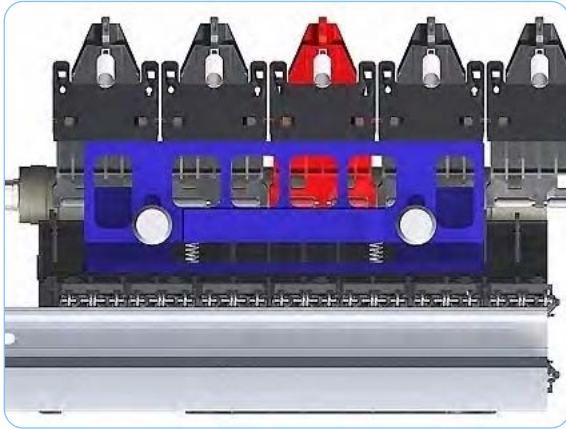

8. Push the replacement Pinchwheel Assembly fully forward so it is firmly against the Pinchwheel Alignment Tool to align it correctly.

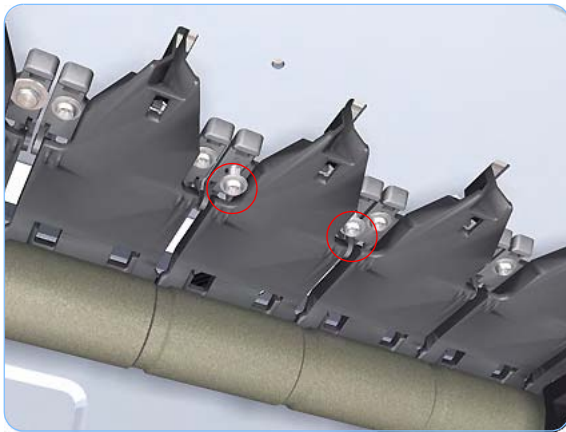

9. Fully tighten the two T-15 attachment screws.

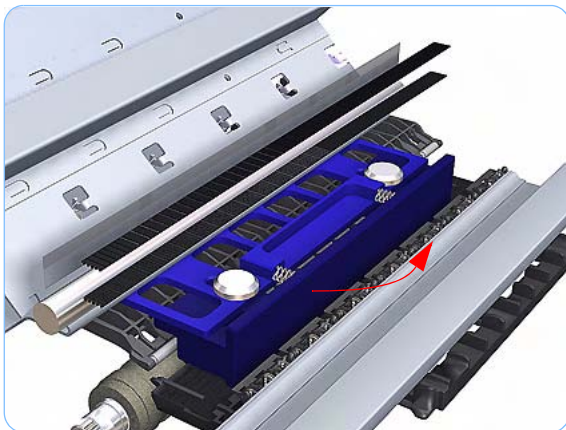

10. Remove the Pinchwheel Alignment Tool.

Pinchwheel Roller

Removal

Switch off the printer and remove the power cable.

1. Open the Window.
2. Raise the Media Lever.

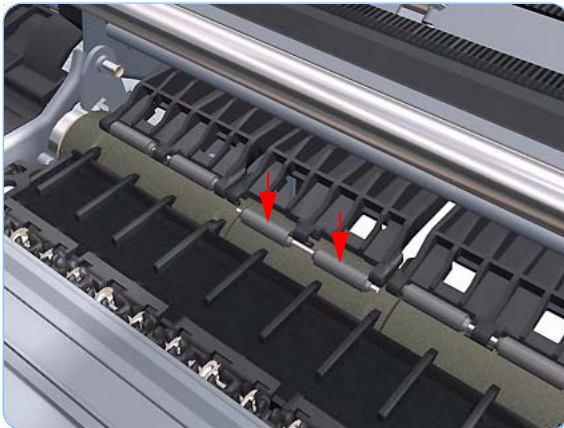
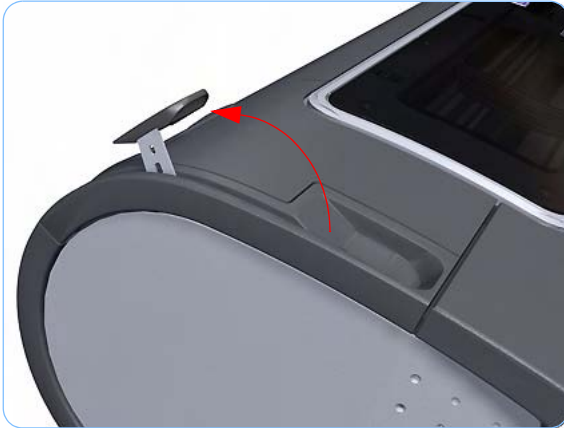

3. Apply enough downward pressure to the Pinchwheel Roller to release it from the Pinchwheel Assembly.

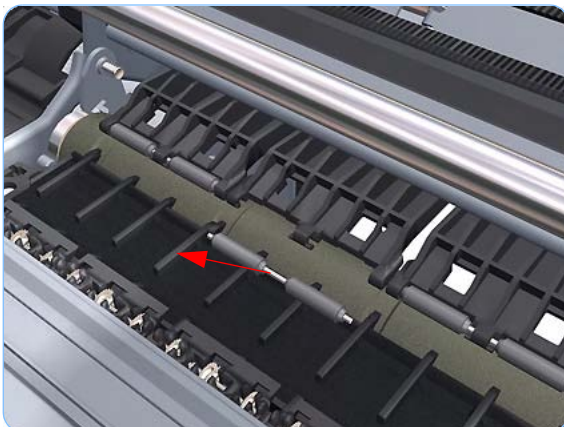

4. Remove the Pinchwheel Roller.

Left Starwheel Lifter

Removal

Switch off the printer and remove the power cable.

1. Remove the Front Cover (refer to page 8-7).
2. Remove the Left Cover (refer to page 8-21).
3. Remove the Electronics Module (Main PCA and PSU) (refer to page 8-141).
4. Remove the Left Spittoon (refer to page 8-150).
5. Remove the Starwheel Assembly (refer to page 8-144).
6. Remove two T-10 screws that secure the Left Starwheel Lifter to the printer.

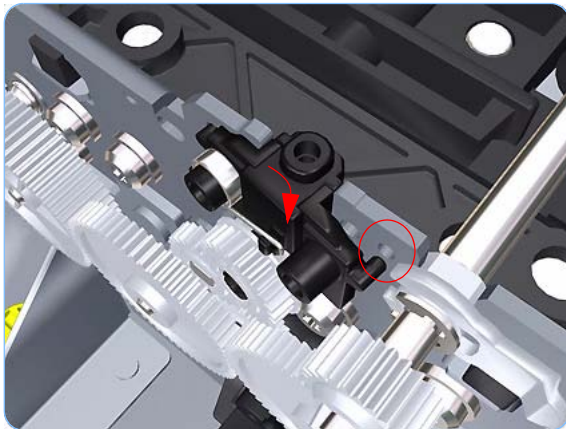
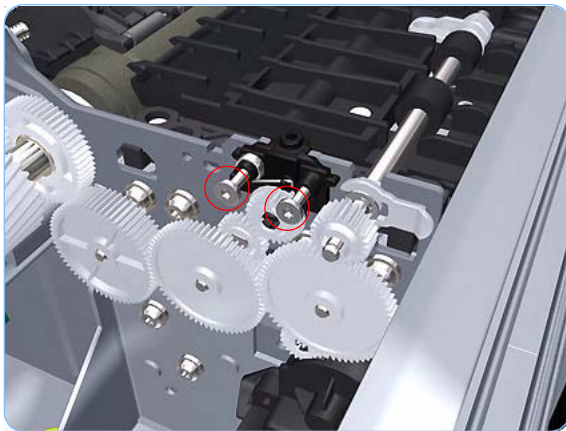

7. Rotate the Left Starwheel Lifter sufficiently to disengage the right attachment lug.

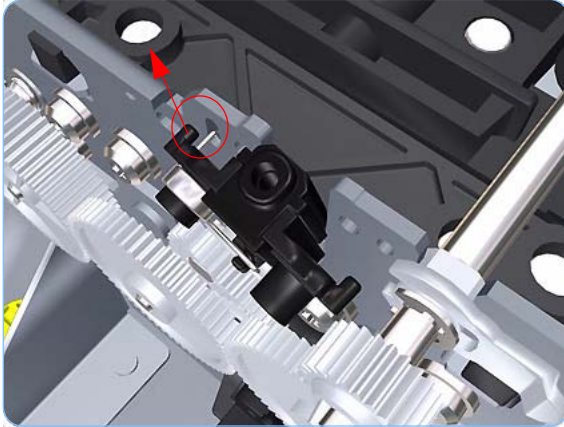

- 8.** Tilt the Left Starwheel Lifter sufficiently to disengage the left attachment lug.

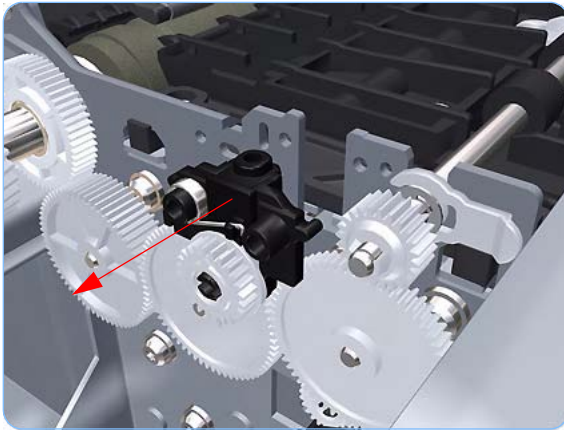

- 9.** Remove the Left Starwheel Lifter from the printer.

Right Starwheel Lifter

Removal

Switch off the printer and remove the power cable.

1. Remove the Front Cover (refer to page 8-7).
2. Remove the Right Cover (refer to page 8-18).
3. Remove the Starwheel Assembly (refer to page 8-144).
4. Loosen the T-10 uncapping screw sufficiently so you can manually move the Carriage Assembly in step 5.

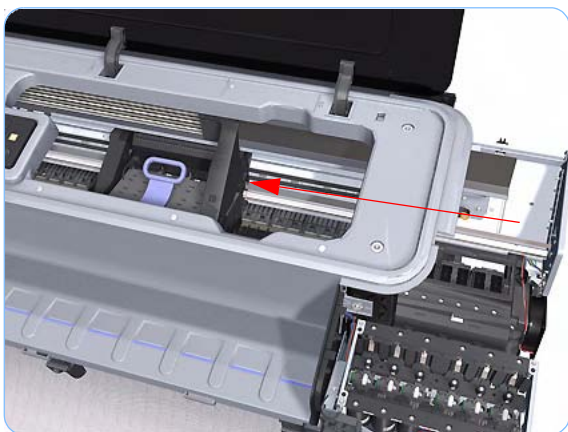
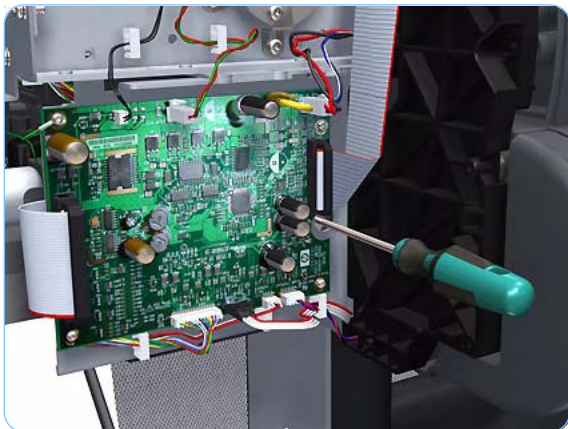

5. Push the Carriage Assembly into the print path.

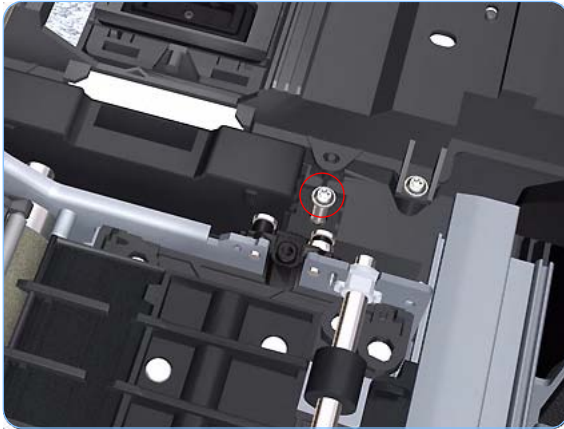

6. Remove one T-15 screw that secures the Drop Detector to the Service Station.

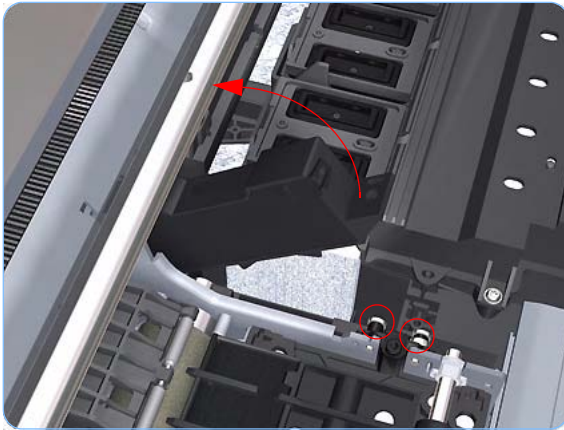

7. Rotate the Drop Detector vertically to gain access to the two screws that secure the Right Starwheel Lifter.

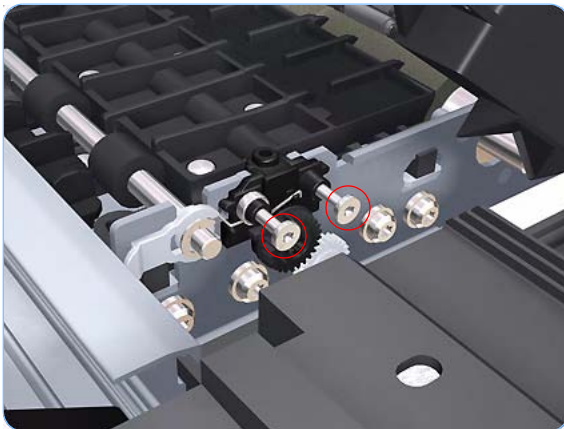

8. Remove two T-10 screws that secure the Right Starwheel Lifter to the printer.

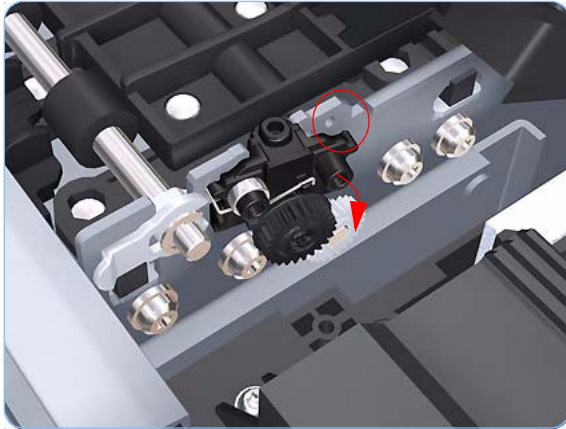

- 9.** Rotate the Right Starwheel Lifter sufficiently to disengage the right attachment lug.

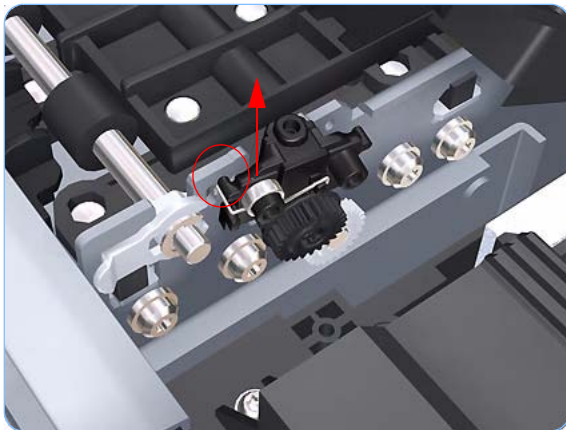

- 10.** Tilt the Right Starwheel Lifter sufficiently to disengage the left attachment lug.

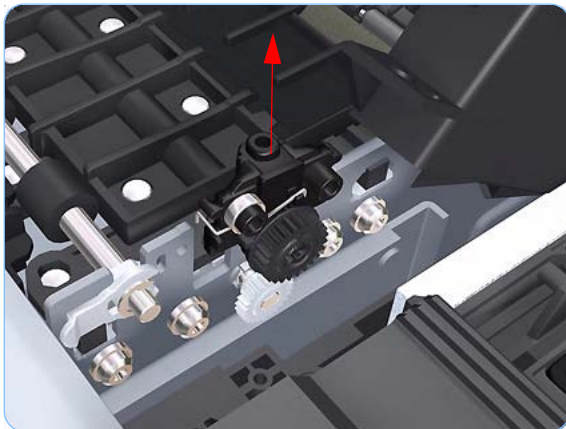

- 11.** Remove the Right Starwheel Lifter from the printer.

Starwheel Motor

Removal

Switch off the printer and remove the power cable.

1. Remove the Front Cover (refer to page 8-7).
2. Remove the Left Cover (refer to page 8-21).
3. Remove the Electronics Module (Main PCA and PSU) (refer to page 8-141).
4. Remove the Left Spittoon (refer to page 8-150).
5. Disconnect the Starwheel Motor electrical connector.

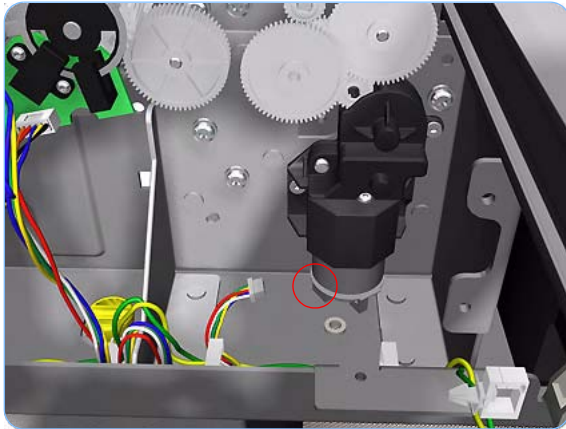

6. Carefully pull the two gear wheels off their shafts to gain access to the Starwheel Motor attachment screws.

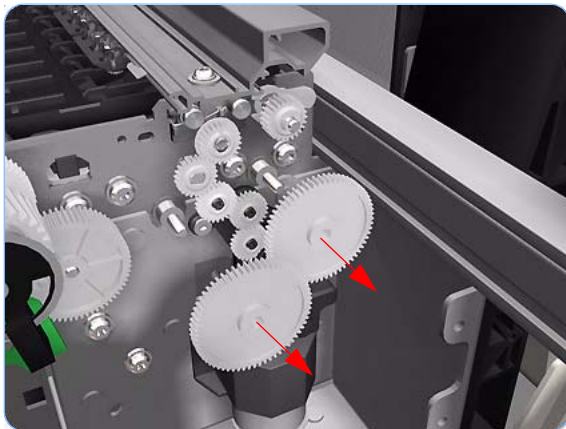

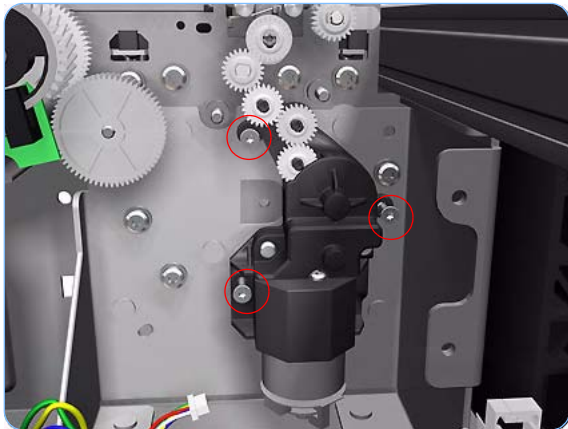

7. Remove three T-15 screws that secure the Starwheel Motor to the printer.

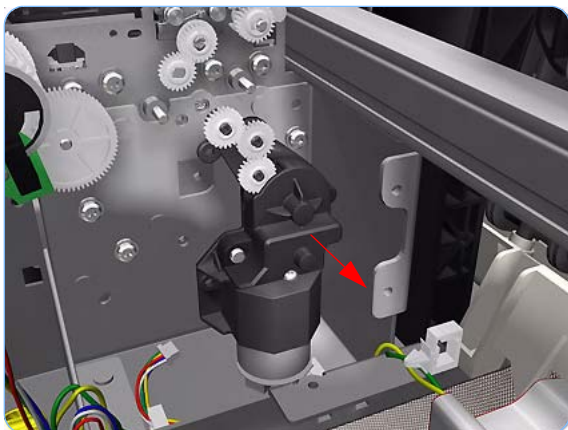

8. Lift the Starwheel Motor out of the printer.

Full Bleed Foam

Removal

Switch off the printer and remove the power cable.

The complete Full Bleed Foam is constructed of three separate sections, left, center and right. This procedure only describes how to remove the left section. Removal of the other two sections is identical.

1. Open the Window.
2. Remove the Left Full Bleed Foam from the left platen.
3. Remove the Platten Middle Foams that are exposed once the Full Bleed Foam has been removed.

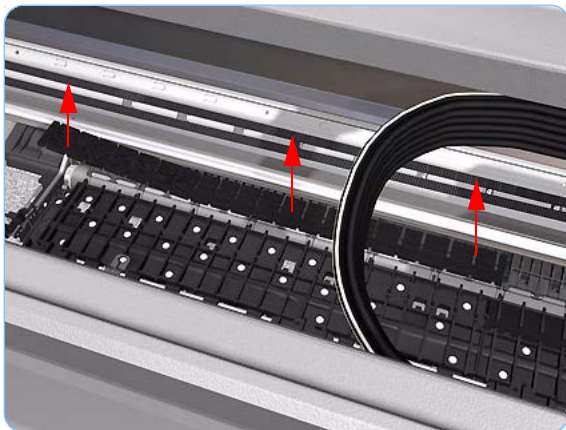

When you reinstall the full bleed foams, take care to correctly seat them to avoid possible damage to the Carriage Assembly

Preventive Maintenance

9

Preventive Maintenance	9-2
Moisture on the Printer	9-2
Noisy Carriage Bushing	9-2
Belt Swelling	9-2
Cleaning the Printer	9-2
General Cleaning	9-3
Cleaning the Drive Roller and Overdrive	9-3
Level of Printer Usage	9-3

Preventive Maintenance

Moisture on the Printer

Users should use the Printer in an environment between 20% and 80% relative humidity. To recover from moisture condensation, turn the Printer Off, and, using the main roller as a reference, wait until the Printer is completely dry before using it again.

Noisy Carriage Bushing

To prevent noisy movement of the carriage, remove aluminum or dust particles from the bushing at the back of the carriage, and from the slider path along which the bushing moves. Lubricate the slider path using the Lubrication Kit (Q5669-60692).

Belt Swelling

To prevent new belts from swelling incorrectly, keep them in their bags with desiccant until you need to install them.

Cleaning the Printer

To maintain the Printer in good operating condition, keep it free of dust accumulation, ink, and other contamination. Cleaning intervals are determined by the Printer environment and by the types of Printer supplies used.

Carriage Assembly Lubrication

To ensure correct operation of the printer you must lubricate the Carriage Assembly whenever any of the following are encountered if:

- The Front Panel displays "Maintenance #1 required".
- There is excessive noise when moving the Carriage Assembly.
- A shut down of the carriage PWM error message appears.
- There are IQ (vertical banding problems).

You should also lubricate the Carriage Assembly whenever you change any of the following service parts:

- The Carriage Rear Bushing.
- The Carriage Assembly.
- The Carriage Rail Oiler.

To lubricate the Carriage Assembly you will require the Lubrication Kit (Q5669-60692). Use the following procedure to lubricate the Carriage Assembly:

- 1 Use the IPA alcohol (Q6675-60070) and the cleaning cloth to clean the Carriage Rail and the Carriage Slider Rod.

- 2 Use an Oil Dispenser (Q6675-60062) to lubricate the Carriage Rail and the Carriage Slider Rod.
- 3 Replace the Carriage Rail Oiler (refer to page 8-101) with the new one contained in the kit and add 2-3 drops of oil to the foam of the Carriage Rail Oiler.
- 4 Use an Oil Dispenser (Q6675-60062) to lubricate the Carriage Rear Bushing.

General Cleaning

Proper general cleaning should include the following:

To prevent an electric shock, make sure that the Printer is switched OFF and unplugged before any cleaning is performed. Do NOT let any water get inside the Printer.

- 1 Blow away dust accumulation with compressed air if available.
- 2 Clean the outer surface of the Printer with a damp sponge or cloth. Use a mild soap and water solution if necessary. Do not use abrasive cleaners.
- 3 Wipe the Printer dry with a soft lint-free cloth.

Cleaning the Drive Roller and Overdrive

**If ink is spilled on the Overdrive, remove the ink immediately. Due to the ink's reflectance, ink on the Overdrive can disrupt the Printer's edge-sensing function. To remove any ink from the Overdrive, perform the following procedure:
Prevent water or other liquids from running onto electrical components or circuits, or through openings in the Electronics Module.**

- 1 Perform the Turn Drive Roller Utility (Refer to Page 4-6).
- 2 Open the window and apply any common household cleaning solution (water based only) to a soft, lint-free rag and apply it to the Drive Roller and Overdrive surface while it is rotating. Make sure that you thoroughly clean the Drive Roller and Overdrive surface.
- 3 Press **Enter** when you have completed the cleaning procedure.
- 4 Allow the Drive Roller to dry before loading media in to the Printer.

Level of Printer Usage

Normal printer use means 6,000,000 Carriage Cycles (which corresponds to approximately 100,000 A0 prints on average). Under normal usage conditions, it will be approximately 5 years before the printer needs maintenance. If the printer is used more than the normal usage conditions,

then it will need maintenance service much more frequently.

One of the EEROM counters is assigned to counting the number of carriage cycles.

Service Part	LIFE_VALUE	Maintenance Advice
Belt Cycles	6000000	PMKIT1
Bushings Life	3000000	PMKIT1
Trailing Cable Cycles	3000000	PMKIT1
Scan Axis Cycles	6000000	PMKIT1
Scan Axis Distance Covered	4500000	PMKIT1
Tubes Cycles	6500000	PMKIT1
Right Spittoon Volume	600000000	PMKIT2
Left Spittoon Volume	51000000	PMKIT2
Cutter Life	2500	PMKIT3

When these components of the Printer exceed this amount, the front panel displays the following message:

"Maintenance #1 required"

"Maintenance #2 required"

Once one of the maintenance advised messages is displayed, the relevant preventive maintenance kit must be used to replace the most worn parts of the printer. Use the Removal and Installation Chapter of this Service Manual as a guide to replace the necessary parts.

Preventive Maintenance Kit #1

The Preventive Maintenance Kit #1 is available in the following different versions:

Z2100 GP Photo Printer (24 inch) P/N Q6675-60032

Part Number	Description
Q6675-60066	Corrugated Box
9223-0756	Paper Wrap
C7769-00200	Label
Q6675-60022	Z2100 Carriage Assy SV
Q5669-60681	Trailing Cable 24 SV
Q6675-60021	Z2100 Ink Supply Tubes 24 SV
Q5669-60673	Belt 24 SV
Q5669-60674	Scan Axis Motor SV
Q5669-60692	Lubrication Kit SV

Z2100 GP Photo Printer (44 inch) P/N Q6677-60015:

Part Number	Description
Q6675-60066	Corrugated Box
9223-0756	Paper Wrap
C7769-00200	Label
Q6675-60022	Z2100 Carriage Assy SV
Q6659-60177	Trailing Cable 44 SV
Q6677-60007	Z2100 Ink Supply Tubes 44 SV
Q6659-60175	Belt 44 SV
Q5669-60674	Scan Axis Motor SV
Q5669-60692	Lubrication Kit SV

Z3100 GP Photo Printer (24 inch) P/N Q5669-60748:

Part Number	Description
Q6675-60066	Corrugated Box
9223-0756	Paper Wrap
C7769-00200	Label
Q5669-60680	Z3100 Carriage Assy SV
Q5669-60681	Trailing Cable 24 SV
Q5669-60671	Z3100 Ink Supply Tubes 24 SV
Q5669-60673	Belt 24 SV
Q5669-60674	Scan Axis Motor SV
Q5669-60692	Lubrication Kit SV

Z3100 GP Photo Printer (44 inch) P/N Q6659-60189:

Part Number	Description
Q6675-60066	Corrugated Box
9223-0756	Paper Wrap
C7769-00200	Label
Q5669-60680	Z3100 Carriage Assy SV
Q6659-60177	Trailing Cable 44 SV
Q6659-60174	Z3100 Ink Supply Tubes 44 SV
Q6659-60175	Belt 44 SV
Q5669-60674	Scan Axis Motor SV
Q5669-60692	Lubrication Kit SV

The Preventive Maintenance Kit #2 is available in the following different versions:

Z2100 GP Photo Printer (24 inch/44 inch) P/N Q6675-67012

Part Number	Description
9211-7156	Corrugated Box
9223-0756	Paper Wrap
C7769-00200	Label
Q6675-60059	Z2100 Service Station SV
Q5669-60709	Left spittoon SV

Z3100 GP Photo Printer (24 inch/44 inch) P/N Q5669-67008

Part Number	Description
9211-7156	Corrugated Box
9223-0756	Paper Wrap
C7769-00200	Label
Q5669-67002	Z3100 Service Station SV
Q5669-60709	Left spittoon SV

About this Edition

This is the 2nd edition, titled:
HP Designjet Z2100/Z3100 GP Photo Printer Service Manual
(models Q6675A/Q6677A/Q5669A/Q6659A) - October 2006

What's in this Service Manual

This manual contains information necessary to test, calibrate and service:

- HP designjet Z2100 GP Photo Printer 24 inch (Model Q6675A)
- HP designjet Z2100 GP Photo Printer 44 inch (Model Q6677A)
- HP designjet Z3100 GP Photo Printer 24 inch (Model Q5669A)
- HP designjet Z3100 GP Photo Printer 44 inch (Model Q6659A)

For information about using these printers, refer to the corresponding User and Quick Reference Guides.

The procedures described in this manual are to be performed by HP-qualified Service Personnel only.

