



# RESIDENTIAL TRUS-T-LIFT™ INSTALLATION MANUAL



This page is left intentionally blank.

# Contents

Lift Diagrams .....	2
Section 1: Introduction .....	4
1.1: Online Resources .....	4
1.2: Installer Contact Information.....	4
Section 2: Safety Information.....	5
2.1: Safety Symbols and Definitions .....	5
2.2: Additional Symbols.....	5
2.3: Safety Notes .....	6
Section 3: Pre-Installation.....	7
3.1: Tools.....	7
3.2: Table of Provided Fasteners .....	8
3.3: Site Preparation .....	9
3.4: Unpacking.....	10
Section 4: Installation.....	12
4.1: Base Frame .....	12
4.2: Locating Lift Keys .....	13
4.3: Platform.....	14
4.4: Plug in and Test Operation .....	16
4.5: Toe Plate.....	17
4.6: Platform Walls.....	20
4.7: Final Positioning & Leveling.....	21
4.8: Platform Tilt.....	22
4.9: Setting the Upper Limit Bracket .....	23
4.10: Anchoring .....	25
4.11: Installing Additional Components.....	25
Section 5: Testing.....	26
5.1: Full Load Testing.....	26
5.2: Upper Limit and Upper Final Limit Switch.....	26
5.4: Lower Limit Switch .....	27
5.5: Additional Testing Notes.....	27
5.6: Reinstalling the Front Cover .....	28
Section 6: Troubleshooting .....	29

- For additional instructions on installing a Carriage Gate or Safety Pan, please see ***“Trus-T-Lift Supplemental Manual #1 – Carriage Gate and Safety Pan”***.

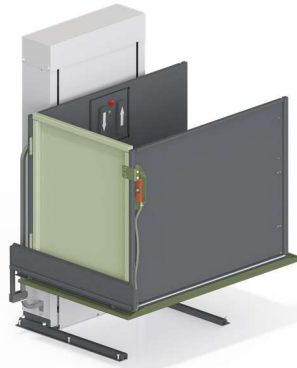

- For additional instructions for installing landing devices such as an interlock or an upper landing gate, please see ***“Trus-T-Lift Supplemental Manual #2 – Landing Devices”***.



- For additional instructions for installing a Tall Tower Trus-T-Lift (<52” travel height), please see ***“Trus-T-Lift Supplemental Manual #3 – Tall Tower”***.



- For additional instructions for installing emergency operation devices such as a UPS or a Tower of Power, please see ***“Trus-T-Lift Supplemental Manual #4 – Emergency Operation Devices”***.



## Lift Diagrams

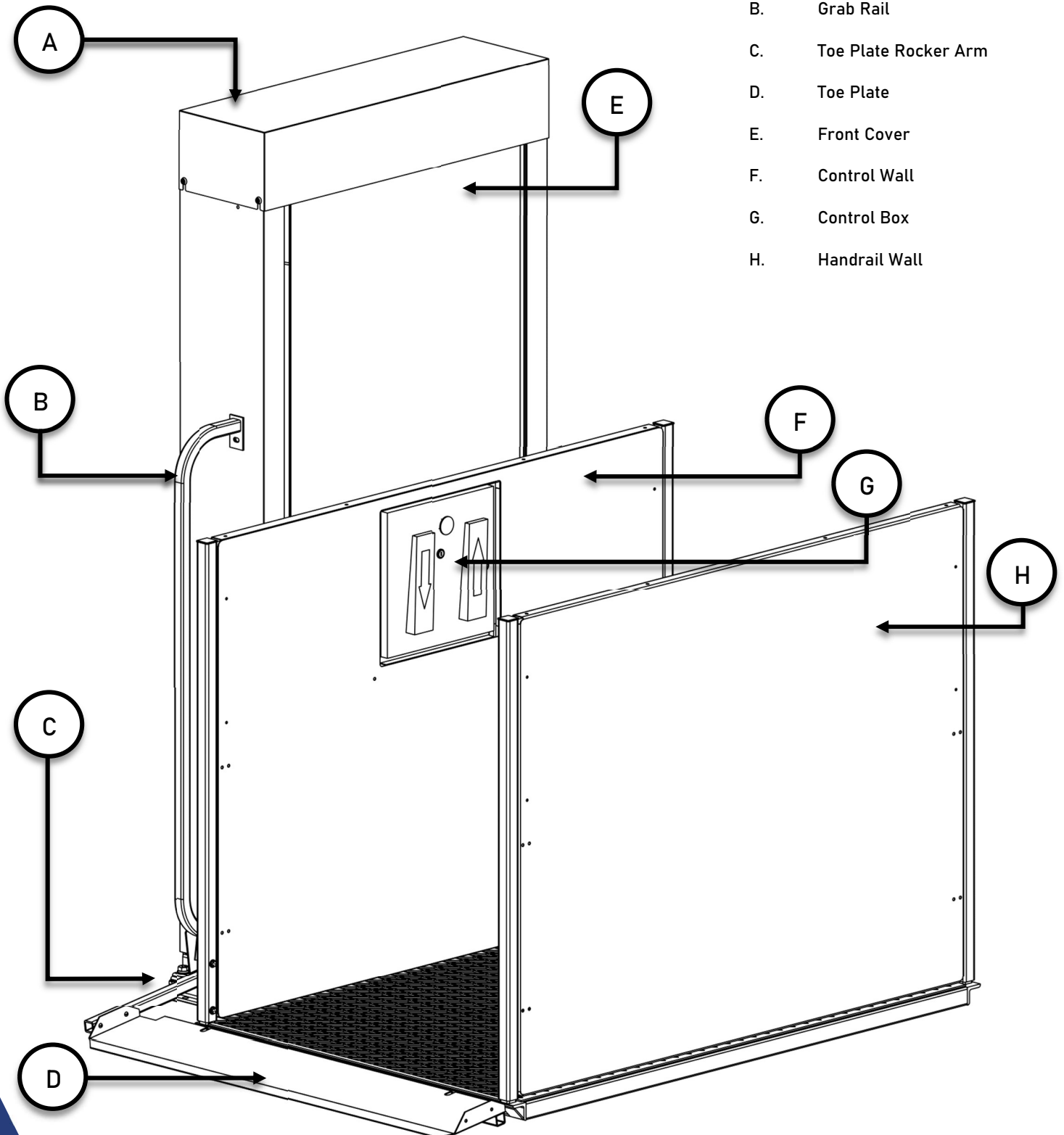

- A. Lift Motor
- B. Drive Screw
- C. Guide Rail Tube
- D. Upper Limit Bracket
- E. Guide Frame
- F. Upper Limit Switch
- G. Lower Limit Switch

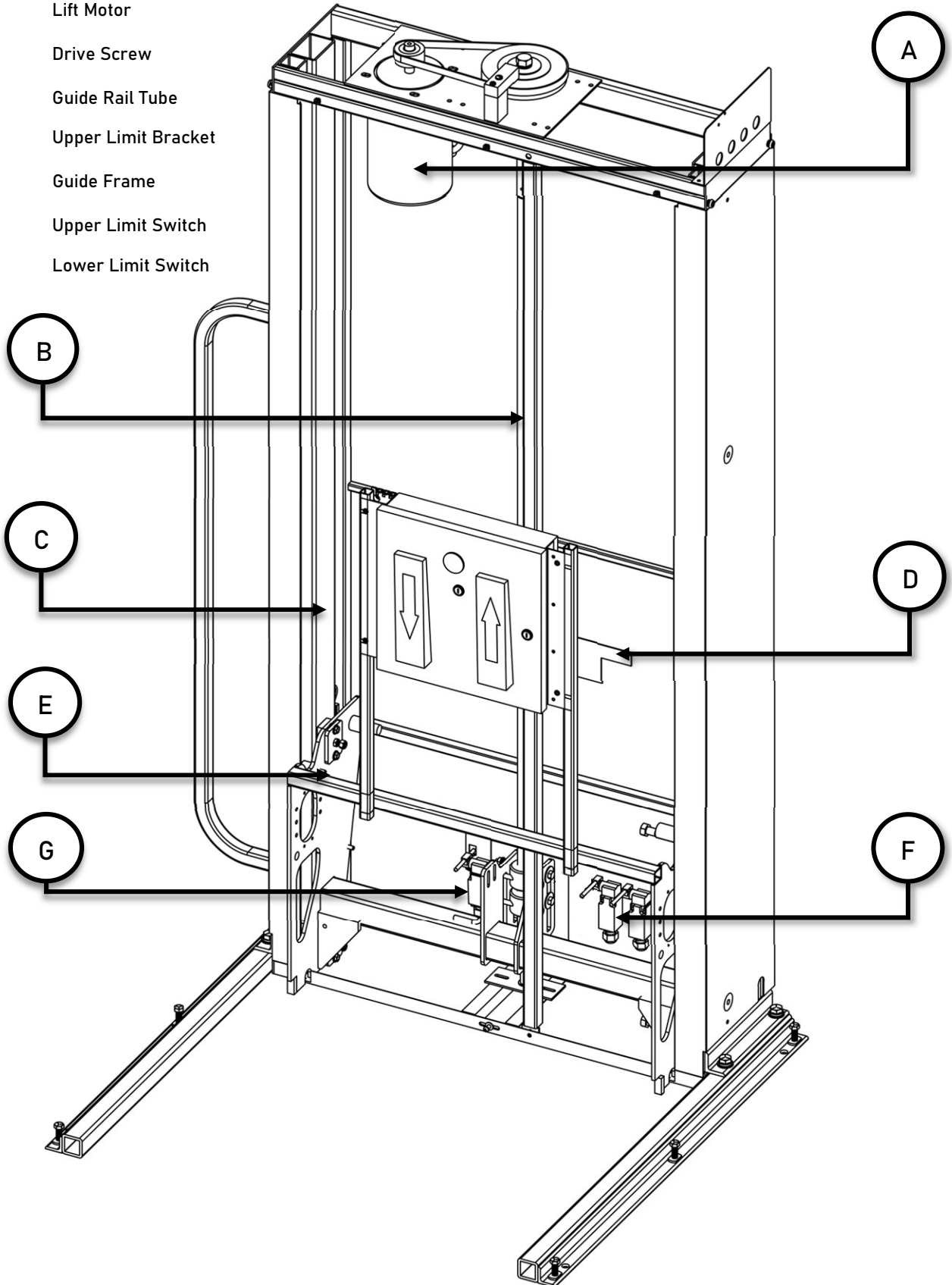

## Section 1: Introduction

Thank you for selecting the Trus-T-Lift™. When operated properly, the Trus-T-Lift™ is designed to provide years of trouble-free service. This manual is provided to walk you through installation safely and efficiently. Please read this manual thoroughly before installing and operating your lift for the first time. We recommend your lift be installed and serviced by a qualified technician.

### 1.1: Online Resources

---

Additional resources for install such as product updates and installation videos, are available online on our website [trustram.com](http://trustram.com).

### 1.2: Installer Contact Information

Affiliated Company:
Phone Number:
Street Address:

## Section 2: Safety Information

### 2.1: Safety Symbols and Definitions

The following notations will be used through this manual to indicate areas that may present special risks or consideration.

#### DANGER

Danger messages indicate an imminently hazardous situation, which, if not avoided, could result in serious injury or even death.

#### Caution!



Caution messages indicate a potentially hazardous situation which, if not avoided, could result in serious injury, death, or damage to equipment.

#### Note

Note messages provide information, such as reminders, general information or additional guidelines that may provide guidance to the installer.

### 2.2: Additional Symbols

The following are additional symbols and conventions used through the manual:

	<p><b>Detail callout</b>, used to call attention to a detailed mentioned in the body of the instructions.</p>		<p><b>Step Callout</b>, labels which step the given diagram relates to</p>
---	---	---	--



## 2.3: Safety Notes

---

### Caution!

Read all instructions thoroughly before installation or use of this lift. Failure to follow the instructions in this manual and the associated manuals for testing and operation could result in serious injury or death. In addition, it will render RAM's warranty null and void.

Do not connect or disconnect wiring while equipment power is on. Before servicing, disconnect all power to the equipment. Failure to do so could result in significant injury or even death.

System may start unexpectedly upon application of power. Unpredictable equipment movement may result in serious injury or death. Use caution when applying power to the unit during the installation process.

RAM Elevators + Lifts Inc. (RAM) disclaims any and all liability for any personal injury or property damage resulting from the operation of a product that has been modified from the original design. No person or company is authorized to change the design of the product without written authorization by RAM.

Do not use an improper voltage source or a power source that provides poor quality power. This may present a significant FIRE HAZARD and/or permanent damage to the equipment.

Do not override any of the safety devices provided with the lift. Doing so will likely lead to serious injury or even death.

Ensure that there is nothing obstructing the carriage travel before operating the lift.

Ensure there is a minimum of 2in (50mm) and a maximum of 3in (75mm) clearance between any part or edge of the carriage that could possibly be used as a supporting handhold and any part of the fixed installation to prevent the trapping of a hand during the travel of the carriage. See RAM installation drawings for details.

The lift is intended for use by people and not to be used for cargo or other purposes. Lifting capacity is up to a maximum of 750 lb. unless otherwise noted on the lift and in RAM's supplied documentation. **(DO NOT OVERLOAD THE LIFT)**. Overloading the lift will render RAM's warranty null and void.

This list of warnings may not be exhaustive, due care around equipment should be observed.

## Section 3: Pre-Installation

### 3.1: Tools

The following is the list of tools that must be provided by the installer to complete the installation.

Tools
• Claw Hammer
• 3/8" Socket Ratchet
• 6" Socket Ratchet Extension
• 12" Socket Ratchet Extension
• Side Cutters
• Combination Screwdriver <ul style="list-style-type: none"> <li>○ #2 Phillips and #2 Robertson Bits</li> </ul>
• Large Flathead Screwdriver
• Utility Knife
• Concrete Drill with 3/8" Bit
• Tape Measure

Sockets
• 7/16"
• 1/2"
• 9/16"
• 3/4"









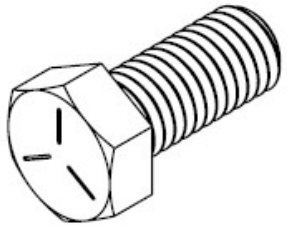

Combination Wrenches
• 3/8"
• 7/16"
• 1/2"
• 9/16"
• 3/4"

Manual Crank Components (These come with your lift)	
• 3/8" Socket ratchet	• 15/16" Socket

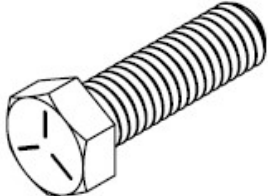
#### Note

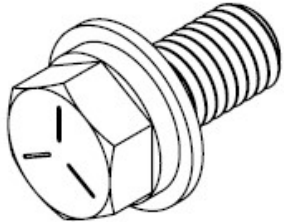
Keep the manual crank components in a safe place near the lift, as in the event of an emergency, you may need them to manually lift or lower the platform.

### 3.2: Table of Provided Fasteners

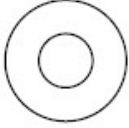
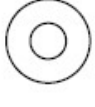
<p><b>Concrete Anchor</b> 2-3/4" Long Galvanised Steel  (1 : 1.5 Scale)</p>		<p><b>Front Cover Screw</b> Phillips Head, 10-32 Thread 1/2" Long Stainless Steel</p>	
<p><b>Platform Mounting Bolt</b> 1/2" Bolt 1-1/2" Long Bronze-Coloured</p>		<p><b>Top Cover Screw</b> Phillips Head, 10-32 Thread 1" Long Stainless Steel</p>	
<p><b>Leveling &amp; Toe Plate Mounting Bolt</b> 3/8" Bolt 1-1/4" Long Galvanised Steel</p>		<p><b>Toe Plate Screw</b> Flathead/Robertson Head (10-32 Thread) 5/8" Long Galvanised Steel</p>	
<p><b>Leg Mounting Bolt (with washers)</b> 1/2" Bolt 1-1/4" Long Galvanised Steel</p>		<p><b>Toe Plate Washer</b> 3/16" ID, 1/2" OD Galvanised Steel</p>	
<p><b>Wall Mounting Bolt</b> 1/4" Bolt 3/4" Long Galvanised Steel</p>		<p><b>Large Plastic Washer</b> 3/16" ID, 9/16" OD White Plastic</p>	
<p><b>Wall Mounting Washers</b> 1/4" ID, 5/8" OD Galvanised Steel</p>		<p><b>Small Plastic Washer</b> 3/16" ID, 7/16" OD White Plastic</p>	

**All figures to scale unless otherwise noted.**

### 3.3: Site Preparation

When preparing to install a Trus-T-Lift, there are a few things that you should consider. The support base for the Trus-T-Lift must be solid and capable of anchoring and supporting the base frame. We recommend a 60 by 60-inch concrete pad approximately 4 inches thick. The pad should be level within a 1/2 inch and smooth with no projections.

The travel distance of a Trus-T-lift is measured from the support base to the upper landing sill. Trus-T-Lift is available in 7 different maximum lifting heights from 28" to 14ft. Each tower can travel a maximum distance indicated by the model number. The model shown in this manual is a 52" tower and can be easily set to automatically stop at any point up to a maximum of 52 inches lifting height.

The travel wall is a barrier that extends from the upper landing sill to the support base and helps to keep the user secure on the platform while operating the lift. This wall must be plumb, smooth, and solid with no projections.

Another consideration is the power source for the lift. Make sure there is a standard 15A/110VAC outlet within 6 feet of the tower location.

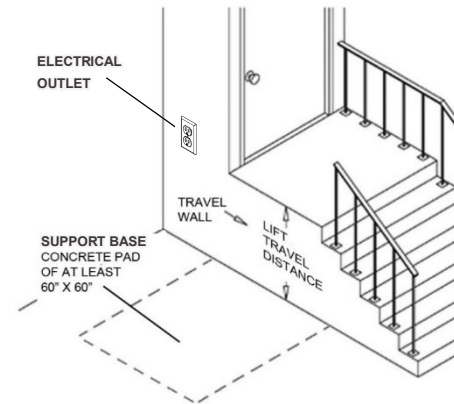

### DANGER

If the travel wall is not prepared in compliance with the above statement, possible crushing or shearing hazards may be present and this will likely cause serious injury or harm.

The Trus-T-Lift is available in two different platform configurations, straight through and 90-degree access. The straight through model has its entrance and exit on either side of the lift, while the 90-degree access allows the user to exit 90-degrees opposite the tower on the upper level. Note that the lower entrance side with the toeplate ramp can be changed from the left or right side of the tower.

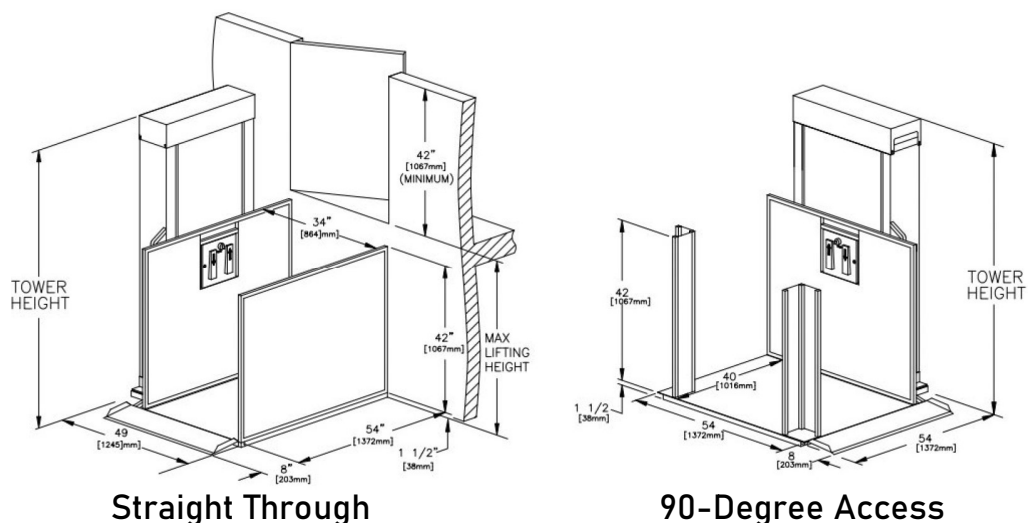

## 3.4: Unpacking

### Materials

Tools		Components	
Name	#	Name	#
• Claw Hammer	1	• Packaged Lift	1
• Utility Knife	1		
• 3/8" Socket Ratchet	1		
• 3/4" Socket	1		
• 3/4" Combination Wrench	1		

### Instructions

#### Note

When you receive your Trus-T-lift, be sure to carefully inspect the packaging for any damage. Note any potential damage on the waybill from the shipper and take photos.

- 1) Remove the outer layers of packaging, careful to not damage any components underneath.



- 2) Retrieve the plastic bag on the front of the unit containing the following:
  - a. Fastener parts bag
  - b. Manual crank ratchet and socket
  - c. An envelope containing the following:
    - i. the installation manual,
    - ii. electrical diagrams,
    - iii. the owner's manual, and
    - iv. any supplementary installation documents.



**Caution!**

Take care to not damage the protective powder coating on the components, as unprotected metal can corrode causing the paint to lift and separate from the metal.



Manual Crank Bag

Fastener Bag



Installation Manual

- 3) Carefully remove the foam wrapping the lift and the components. Set these aside each component. After all the foam is

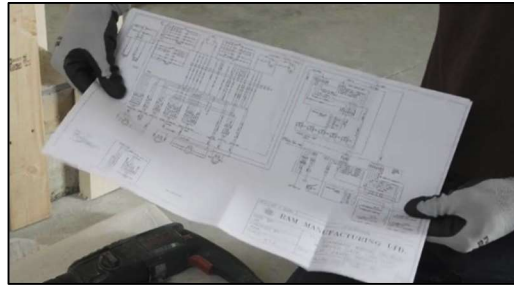

Electrical Diagrams

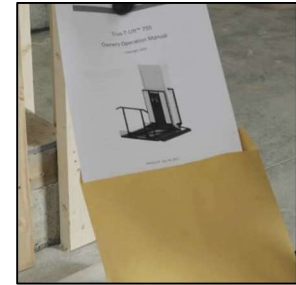

Owner's Manual

removed, you will be left with the lift tower bolted to the pallet.

**Note**

The packing foam your lift is wrapped in can also be used to cushion components against a wall of the floor, to prevent damage to them and the components.

- 4) Remove the section of the pallet shown in the below figure, then remove the bolts fastening the tower to the pallet using the 3/4" socket and combination wrench.

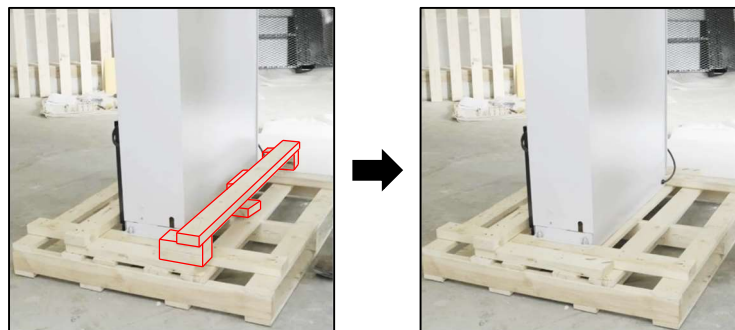
**Caution!**

Use best lifting practises when moving the lift. Not doing so can lead to serious injury.

- 5) Carefully move the lift off of the pallet, and put it near its final location.

## Section 4: Installation

### 4.1: Base Frame

#### Materials:

Tools		Components	
Name	#	Name	#
• 3/8" Socket Ratchet	1	• Base Legs	2
• 3/4" Socket	1	• Tower	1

#### Instructions

- 1) Retract each leveling bolt (3/8" Bolt) ( **A** ) so the legs will sit completely flat on the floor, with no support from the bolts.
- 2) Remove each mounting bolt (1/2" Bolt) with its washers ( **B** ) and slide the legs into place.
- 3) Reinstall the mounting bolts.
- 4) Repeat for the other base leg.

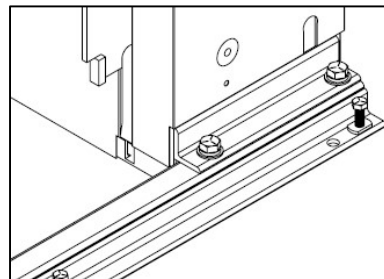
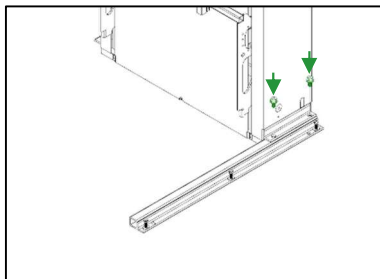
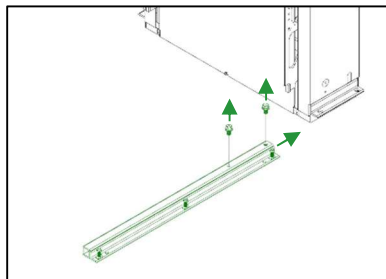
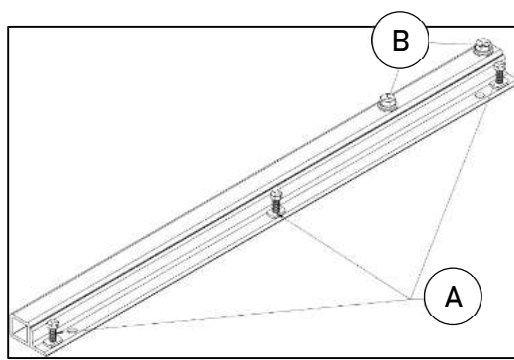



## 4.2: Locating Lift Keys

### Materials

<u>Tools</u>		<u>Components</u>	
Name	#	Name	#
• Side Cutters	1	• Tower and Base Leg Assembly (4.1)	1

### Instructions

- 1) On the front of the tower, you will find the power cord zip-tied to the guide frame. Cut this tie.
- 2) Locate the control box key zip tied to the end of the power cord. Cut the tie and retrieve the key.
- 3) Insert the control box key retrieved in the last step into the keyhole on the right of the control box and apply a small amount of pressure on the lid as you turn the key to open the box.
- 4) Retrieve the on-off keys zip tied to the inside of the front of the control box, and close and lock the box.
- 5) Put the on-off key into the center key slot on the front of the control box and turn it to the right.

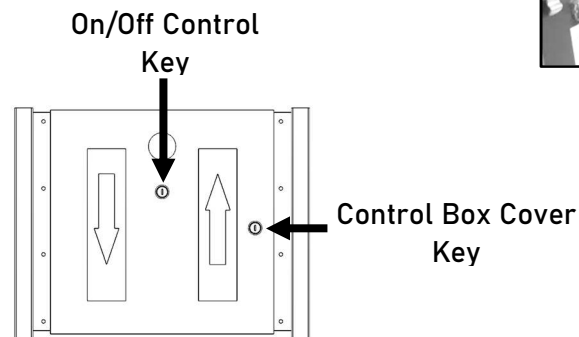
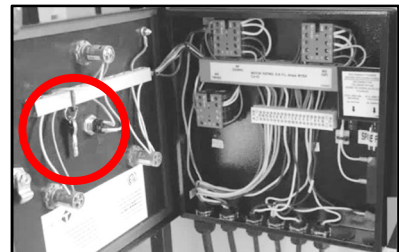
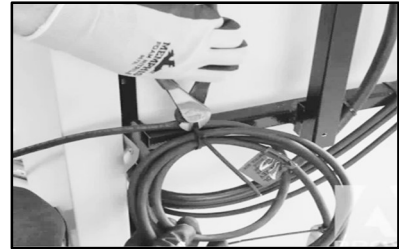



## 4.3: Platform

### Materials

<u>Tools</u>		<u>Components</u>	
Name	#	Name	#
• Phillips Head Screwdriver	1	• Tower and Base Leg Assembly (4.1)	1
• 3/8" Socket Ratchet	1	• Platform	1
• 15/16" Socket	1	• Platform Mounting Bolts (1/2" Bolt)	2
• 3/4" Socket	1		

### Instructions

- 1) Use the Phillips head screwdriver to loosen the screws holding the top cover ( **1** ). Note that they do not need to be removed, only loosened. Remove the top cover.

#### Note

The front panel of the tower is fastened with both screws and snap-together pads, so it may take a small amount of pressure to remove once the screws have been removed.

- 2) Remove the front cover screws ( **2** ) using the Phillips head screwdriver and remove the front panel ( **3** ).

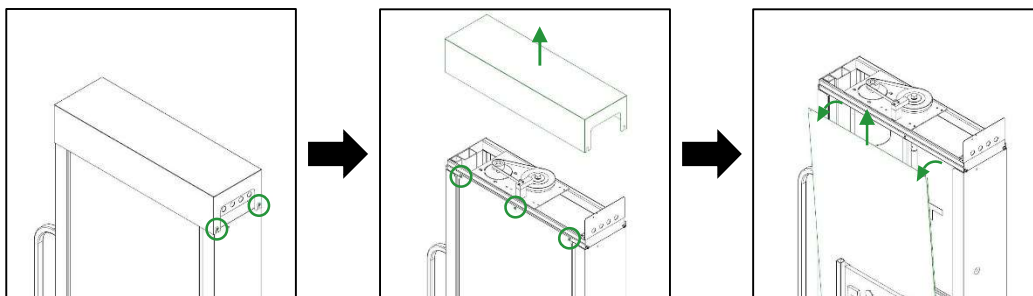

- 3) Carefully slide the platform onto the base legs until it lines up with the guide frame.

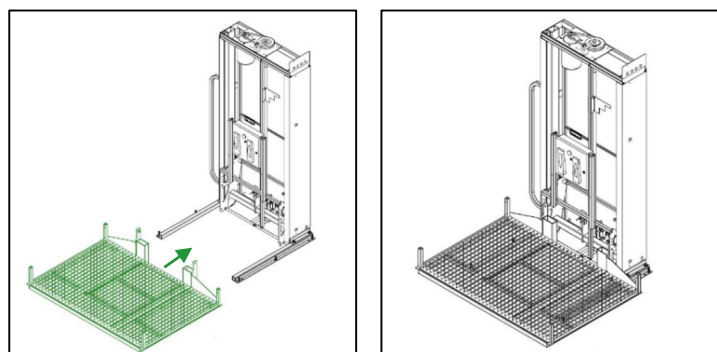

- 4) Use the manual crank wrench and 15/16" socket to lower or raise the guide frame until the bolt holes line up with the holes on the platform.

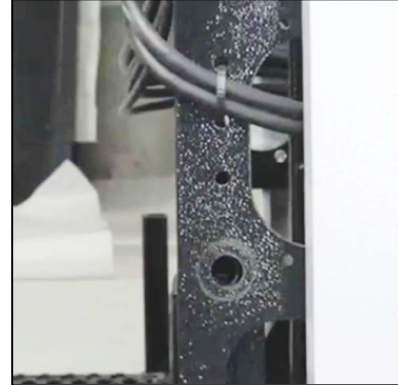
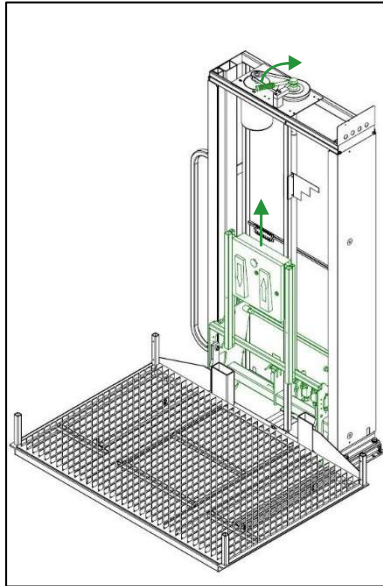
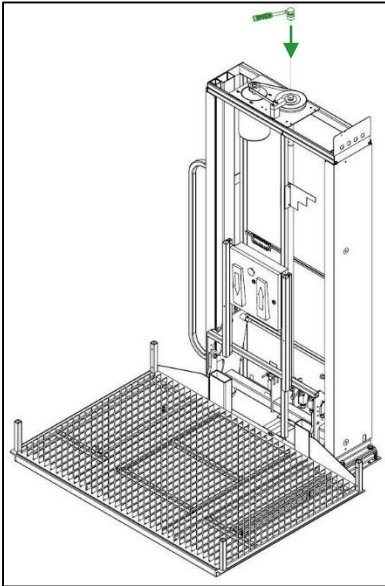

### Caution!

Over-tightening the bolts in the next step can compromise the operation of the lift, so make sure they are only tightened the specified amount

- 5) Fasten the platform to the guide frame using the Platform mounting bolts (1/2" bolts) and the 3/4" socket. Ensure you do not over tighten these (only until one or two threads are visible on the other side of the nut)

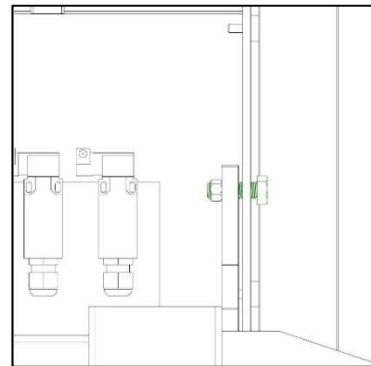
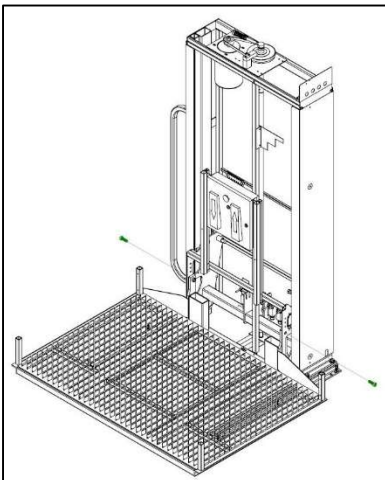

## 4.4: Plug in and Test Operation

### Materials

<u>Tools</u>		<u>Components</u>	
Name	#	Name	#
		• Lift Assembly (4.3)	1

### Instructions

- 1) Slide the top cover back onto the unit, until you hear the top cover switch activate. Note that the smaller plastic washer goes inside the cover, and the larger washer on the outside.

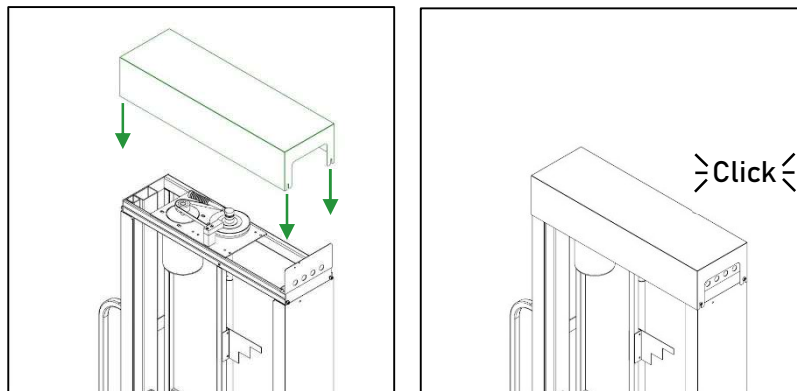

#### Note

You don't need to re-tighten the screws on the top cover, as you will be removing it again later in the installation.

Double check that the emergency stop button is not depressed before carrying out the next steps, and the on/off key is in and turned clockwise.

- 2) Plug the lift into the wall (standard 110V 15A outlet)



### DANGER

The rotating screw will be exposed when running the machine without the front cover. Keep hair, loose clothing, or anything that could get caught in the screw away from the machine.

- 3) Test the lift's operation by pressing the up and down paddles.

## 4.5: Toe Plate

### Materials

<u>Tools</u>		<u>Components</u>	
Name	#	Name	#
• 3/8" Socket Ratchet	1	• Lift Assembly (4.4)	1
• 9/16" Socket	1	• Toe Plate	1
• 6" Extension	1	• Toe Plate Mounting Bolt (3/8" Bolts)	2
• Flathead Screwdriver	1		
• Utility Knife	1		

### Instructions

#### Note

On some units, the toe plate will come pre-installed. If your unit already has its toe plate connected to the platform, skip to step 4.

#### Caution!

For power wheelchairs that can exert loads higher than 125 lb of force, a toe plate is insufficient safety protection, and a carriage gate option would also be required.

- 1) Raise the platform to a good working height (about 2-3 ft off the ground)
- 2) Line the holes in the toe plate with the holes on the platform and flip the plate up. The side these holes are on will change depending on what orientation you ordered your lift in.

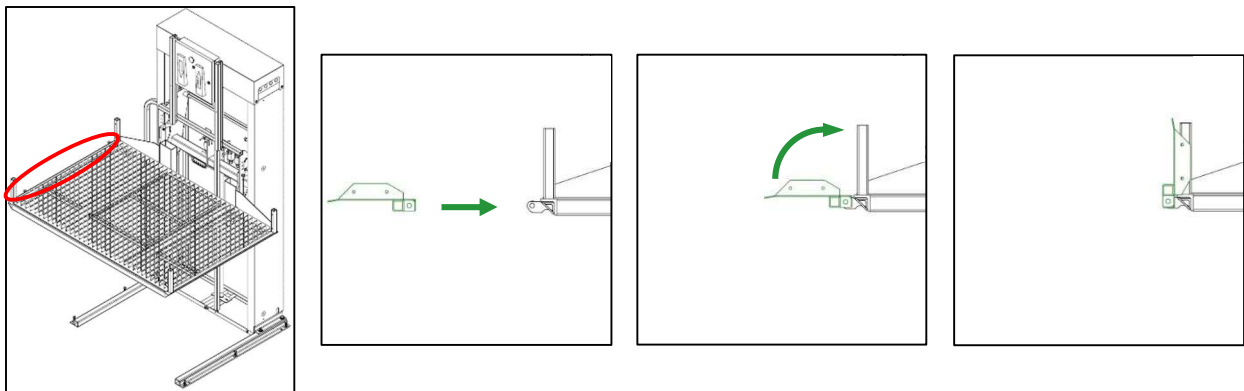

#### Note

In the next step, do not over-tighten the bolts, as the toe plate will not be able to operate correctly.

- 3) Install the Toe Plate Mounting Bolts (3/8" bolts) using the ratchet, socket, and extension.

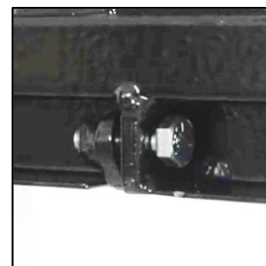
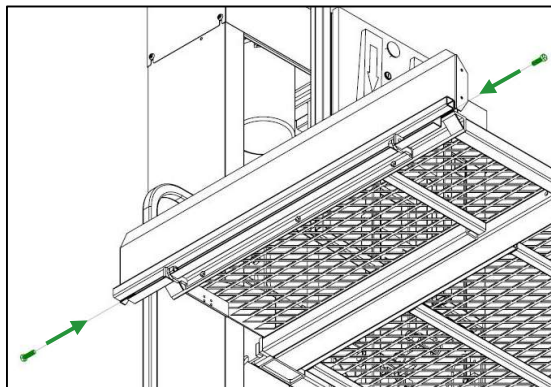

- 4) Use the utility knife to remove the packaging on the grab rail and rocker arm.

- 5) Remove the #10 screws from the rocker arm

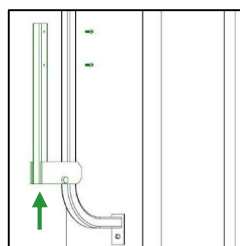
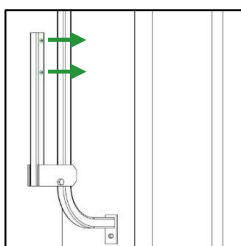
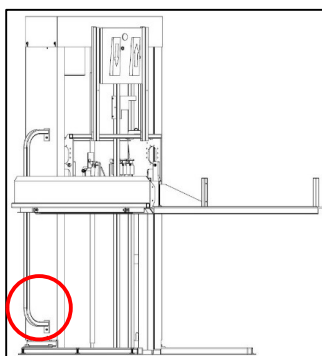

- 6) Line up the screw holes with the holes on the side of the toe plate, and fasten the rocker arm to the toe plate.

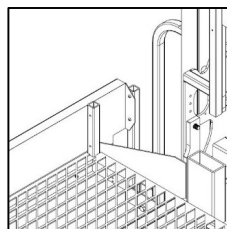
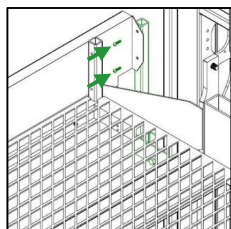
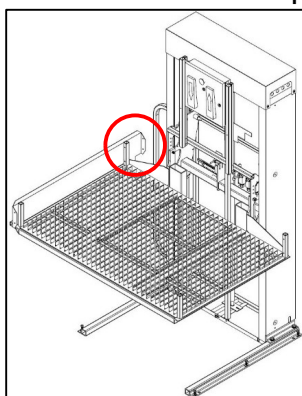

- 7) Test the toe plate's operation by raising and lowering the platform. It should come down to become a ramp at the bottom, and raise fully vertically as the platform raises.

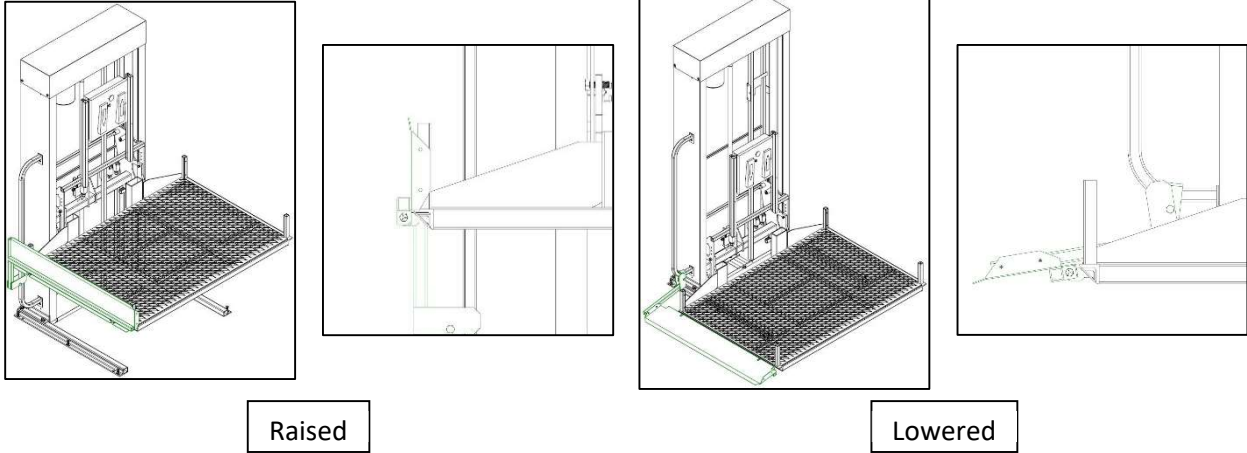
**Caution!**

The toe plate is designed to resist a static force of 125 Lbs. to prevent a manual wheelchair from rolling off the platform. It is recommended that a carriage gate is used to provide additional protection when lift is being used by powered wheelchairs, powered scooters, standing persons or if the user has limited control of their wheelchair when entering the lift at the upper landing.

## 4.6: Platform Walls

### Materials

<b>Tools</b>		<b>Components</b>	
<b>Name</b>	<b>#</b>	<b>Name</b>	<b>#</b>
• 3/8" Socket Ratchet	1	• Lift Assembly (4.5)	1
• 7/16" Socket	1	• Control Wall	1
		• Handrail	1
		• Wall Mounting Bolts (1/4" Bolts)	8
		• Wall Mounting Washers	8

### Instructions

#### Note

If your model is a 90-degree access, as opposed to the straight-through model shown in this manual, refer to the "90-Degree Access Wall Panel Installation Guide" included with your documentation.

- 1) Slide the control wall into place onto the two corner posts in the tower side of the platform.
- 2) Fasten the wall to the posts using two bolts with washers on each side.
- 3) Repeat this process for the handrail.

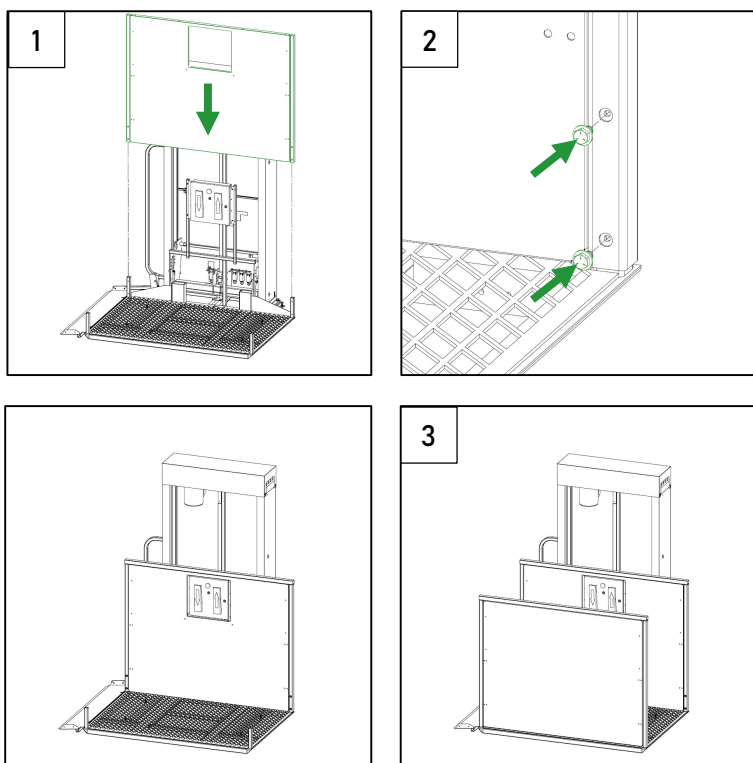

## 4.7: Final Positioning & Leveling

### Materials

<b>Tools</b>		<b>Components</b>	
Name	#	Name	#
• 3/8" Socket Ratchet	1	• Lift Assembly (4.6)	1
• 9/16" Socket	1		
• Large Flathead	1		
• 6" Extension	1		

### Instructions

#### Caution!

Use best lifting practises when moving the lift. Not doing so can lead to serious injury.

- Carefully move the lift into its final position. When the lift is close, use the large flathead to fine-tune the position by using it as a lever to nudge the legs. Note that there should be a gap between the platform and the travel wall of 1/4" to 3/4".
- Lower the corner leveling bolts on each leg using the 9/16" socket and 6" extension until the legs rest **only on the bolts**, with none of the base touching the ground.

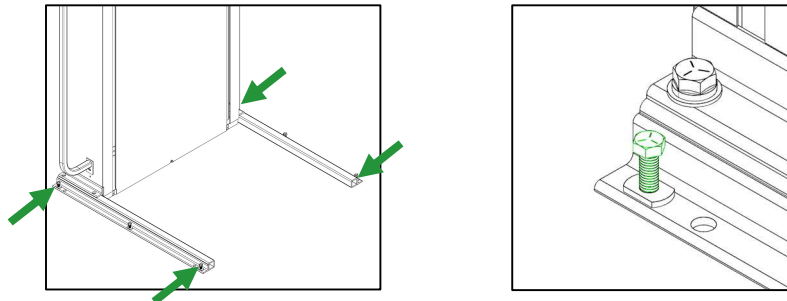
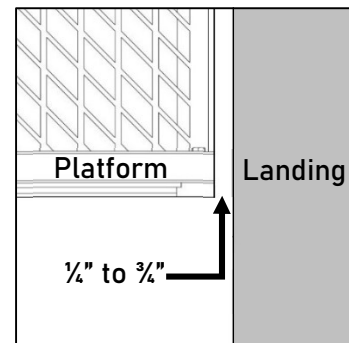

- Adjust the levelling bolts so that the travel line of the platform is parallel with the travel wall.

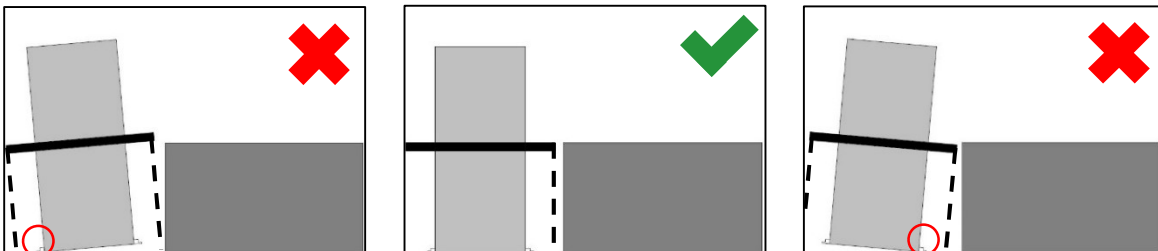



## 4.8: Platform Tilt

### Materials

<b>Tools</b>		<b>Components</b>	
<b>Name</b>	<b>#</b>	<b>Name</b>	<b>#</b>
• 9/16" Wrench	1	• Lift Assembly (4.7)	1

### Instructions

- 1) Locate the platform's tilt bolts. There is one on either side of the tower.

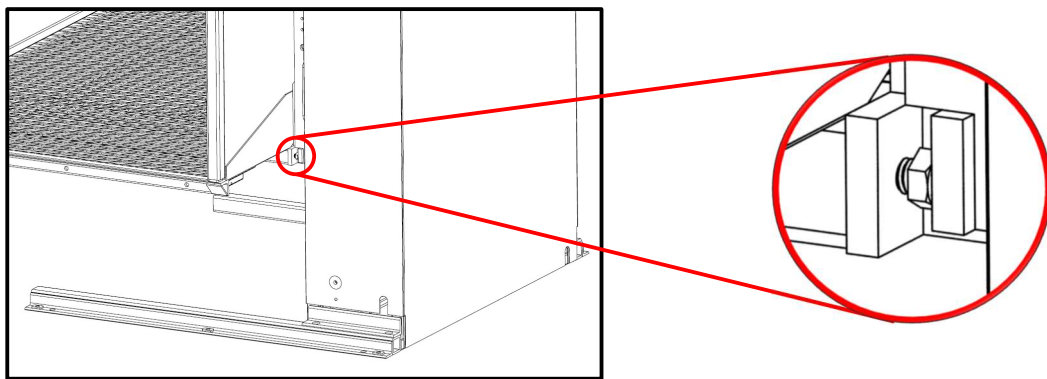

- 2) Equally adjust both tilt bolts until the edge of the platform opposite the tower lifts slightly higher than the top landing (1/8" to 3/16"). This way, when the lift is loaded, it will be level to the landing.

#### Note

Ensure that the tilt bolts are adjusted equally, as unequal tilt bolts will make the platform bounce like a spring.

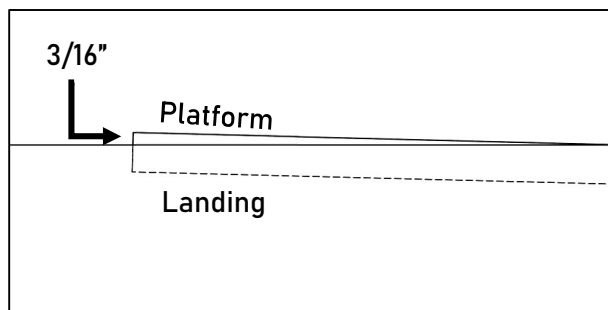

Un-Loaded

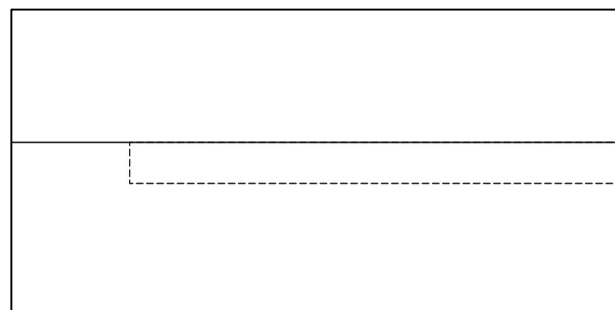

Loaded

## 4.9: Setting the Upper Limit Bracket

### Materials

<u>Tools</u>		<u>Components</u>	
Name	#	Name	#
• Tape Measure	1	• Lift Assembly (4.8)	1
• Combination Screwdriver	1		

### Instructions:

- 1) The bracket is set to the maximum travel and pinned in place at the factory with a self tapping locking screw to prevent movement during shipping. With the platform positioned at the bottom, remove the *existing* self tapping locking screw (A) from the upper limit bracket and discard. The *new* self tapping locking screw (B) is taped to the bracket. Leave the new screw taped in place until adjustment is complete.

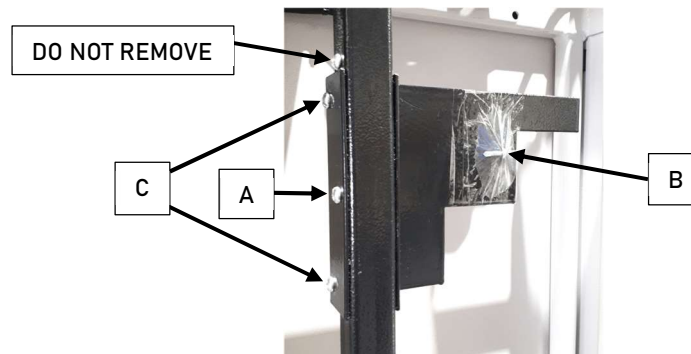

- 2) Loosen the two clamping screws (C) on the upper limit bracket. The bracket should now slide freely.
- 3) Slide the bracket down to a position **slightly lower** than required to activate the upper limit switch when the platform is raised to the upper landing (i.e. the lift should stop short of the upper landing when run upwards). Final adjustments will be made later.
- 4) Tighten the two clamping screws on the upper limit bracket so that it does not move, but **do not insert the self tapping locking screw yet.**

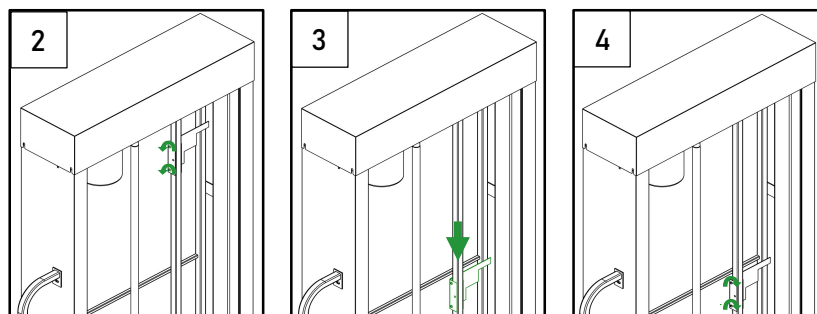

- 5) Run the lift upwards with a moderate load (approx. 200lbs) until it stops automatically and measure the vertical distance "D" from the platform to the upper landing (the platform should stop below the upper landing). Translate this measurement to the tube that the upper limit bracket slides on.
- 6)

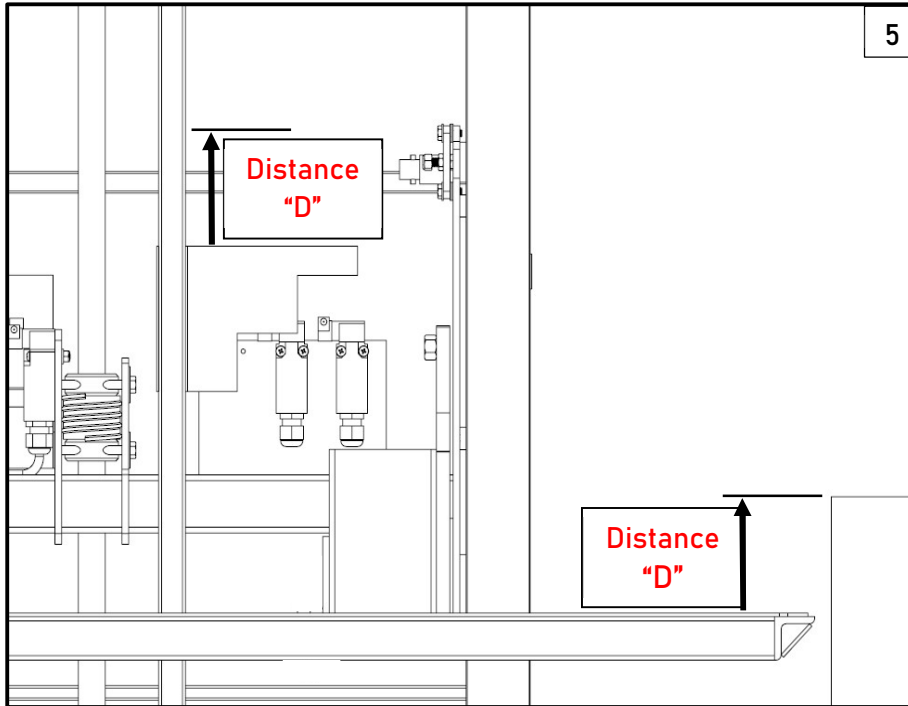

- 7) Adjust the upper limit bracket by moving it up distance "D".
- 8) Run the platform down and back up again to confirm the lift stops level with the upper landing automatically.

#### Note

After the next step, fine adjustment is more difficult, so make sure that you are happy with the position of the bracket at this point.

- 9) Use the *new* self tapping locking screw that is taped the bracket to pin the upper limit bracket securely in place.

## 4.10: Anchoring

### Materials

<u>Tools</u>		<u>Components</u>	
Name	#	Name	#
• Concrete Drill & 3/8" Bit	1	• Lift Assembly (4.9)	1
• Claw Hammer	1	• Anchors	4
• 9/16" Wrench	1	• Front Cover	1
• Phillips Head Screwdriver	1	• Front Cover Screws	3

### Instructions

#### Note

Once the base legs are anchored into place, it is very difficult to change the lift's location, so it is important that you are happy with its position before continuing the installation.

Provided with your lift are four **concrete** anchors. If you are anchoring the lift into another material, please use anchors specifically for that material.

- 1) Drill **four** holes using the holes - 2 in each base leg ( A ) - up to the mark you put on the bit.
- 2) Insert the anchors into the holes threaded side-up, and hammer in. Tighten the nut on the anchors with the 9/16" wrench to set them in place.

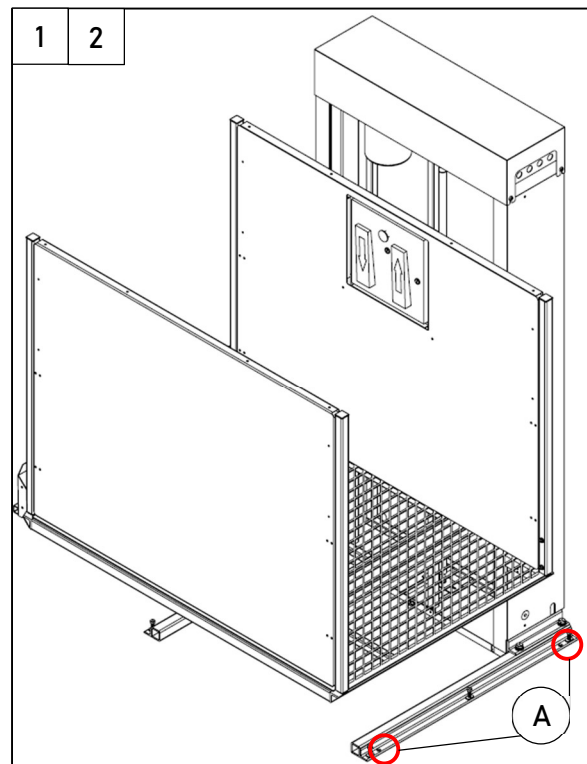

#### Note

The front cover of the lift will not be reinstalled until after testing has been carried out (5.6: Reinstalling the Front Cover).

## 4.11: Installing Additional Components

If you ordered your lift with an additional component that is not referred to in this manual, proceed to the supplemental manual for such add on now (ex. Call Station, UPS, etc.)

## Section 5: Testing

### 5.1: Full Load Testing

Every lift should be weight tested once the installation for mechanical and electrical items is complete to ensure that the lift is operating correctly. All lifts are tested at the factory, but they are then disassembled and shipped to sites across North America.

Weight testing comprise 2 elements:

1. Maximum Lifting capacity – apply full load (750 lb) to the lift in the center of the platform, the lift should travel to the upper landing without hesitation and stop within 3/8" of the upper landing – repeat two or three times.
2. Overload braking – North American Safety code requires that a lift is capable of braking and holding 125% of the rated load. To test this, start with the lift at the upper landing and apply 125% of rated working load (950 lb). Lower the lift and stop several times to ensure that the lift will brake without unintentional movement. **The lift is not required to lift 125% (950 lb) of working load.**

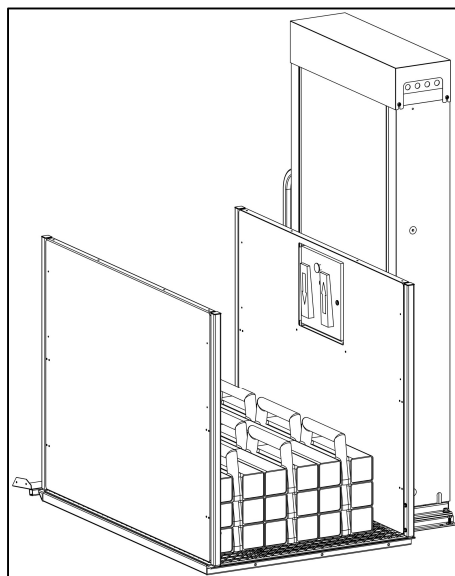

### 5.2: Upper Limit and Upper Final Limit Switch

Each lift is equipped with an “upper limit switch” and an “upper *final* limit” switch.

The upper limit switch indicates to the control circuitry that the lift has reached the upper landing and stops the lift. This is set during the installation process.

The upper *final* limit switch is a safety feature which indicates to the control circuitry that the lift has gone *higher* than the upper limit switch. It should not engage under normal operation and indicates that there is a problem with the lift and stops the lift from moving either up *or* down.

To test the upper final limit switch, raise the lift to the upper landing (where the upper limit switch engages, and the lift automatically stops). Using the manual crank, continue to raise the lift above the upper landing (approximately 2”) until the upper final limit switch engages. Attempt to run the lift up *and* down. **The lift should not run in either direction.** When the test is

complete, use the manual crank to lower the lift until the upper final limit switch disengages and the lift can once again be lowered and raised.

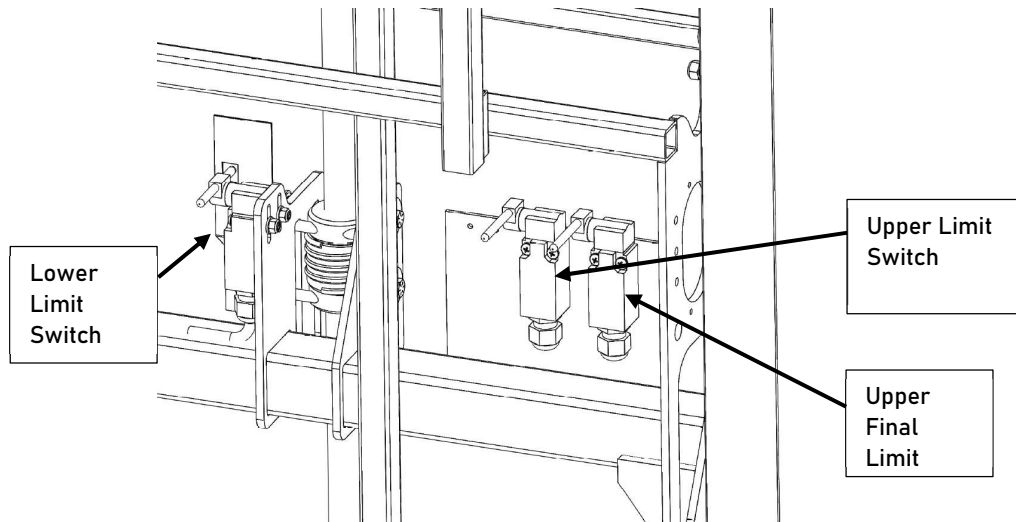

#### 5.4: Lower Limit Switch

Verify that as the platform comes in to contact with the support base, the limit switch is engaged with the red safety bracket and that this cuts power to the motor.

Also verify that the drive screw stops spinning prior to the drive nut bolts hitting the end of the slots in the guide frame.

#### 5.5: Additional Testing Notes

- **Toe Plate**

If your lift has a toe plate ramp you should verify that the ramp deploys properly and makes full contact with the lower landing. The action should be smooth and consistent without binding or jerking of the motion.

When the toeplate ramp is in the up position both the ramp and the linkage mechanism should resist up to 125lb of force without deforming.

- **Emergency Stop**

Verify that is the E-stop button is pressed then the lift will not operate.

- **Key Switches**

Verify that when a key switch at each landing or on board the lift is turned to the off position the corresponding buttons and control paddles do not operate the lift.

- **Top Cover Switch**  
Verify that when the top cover is removed that the lift will not operate.

## 5.6: Reinstalling the Front Cover

### Materials

<b>Tools</b>		<b>Components</b>	
Name	#	Name	#
• Phillips Head Screwdriver	1	• Front Cover	1
		• Front Cover Screws	3

### Instructions

- 1) Remove the top cover.
- 2) Slide the front cover back into place.

#### Note

There is a small alignment tab in the center at the bottom of the panel that will help seat the panel.

- 3) Once the tab is in the slot, line up the three screw holes and snap-together pads and snap into place.
- 4) Reinstall the three front cover screws.
- 5) Slide the top cover on again, making sure that the smaller plastic washer is on the inside of the cover, and tighten the four top cover screws. Be careful to not over-tighten these.

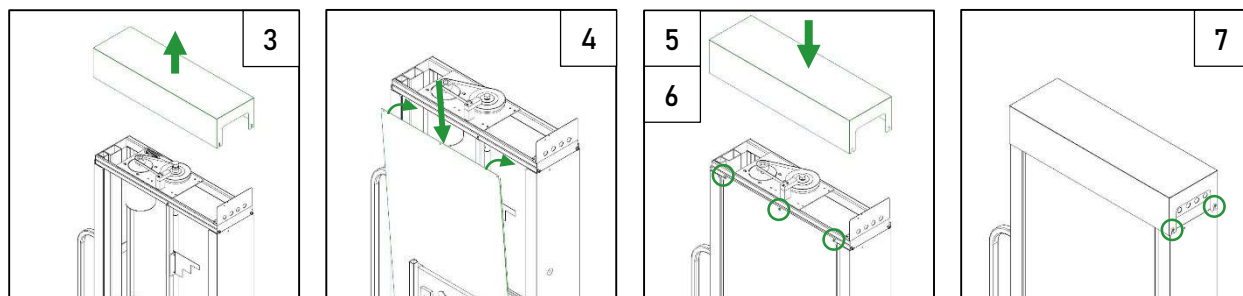
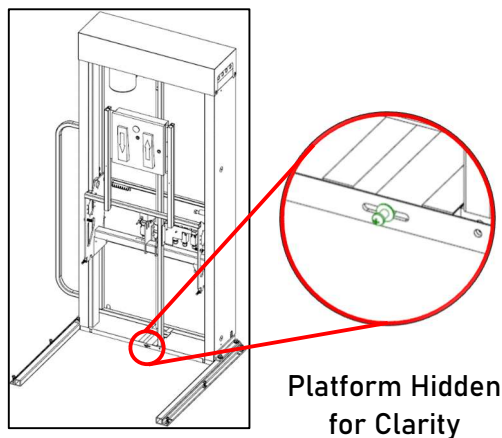

## Section 6: Troubleshooting

Problem	Possible Solution
Lift runs up but not down	<ul style="list-style-type: none"> <li>• Check lower limit switch is resting inside the red safety bracket, and not activated.</li> <li>• <b>If you have a safety pan</b>, check that it is free floating and that the switches in each corner and the center are not tripped.</li> <li>• <b>If you have a safety pan</b>, also check that it is wired correctly into the junction box located behind the control wall, see “Safety Pan and Carriage Gate” supplementary manual.</li> </ul>
Lift will not run up or down	<ul style="list-style-type: none"> <li>• Check that the lift is plugged in to the outlet and test and that there is power to the outlet using another plugin device (lamp or small electrical appliance).</li> <li>• Ensure that the power key is turned clockwise to the horizontal “on” position</li> <li>• Check that the emergency stop button is pulled out by pushing and pulling the button to test that it is operating properly. It should snap when pushed in and pulled out.</li> <li>• Check that the top cover switch is properly depressed when the top cover is on.</li> <li>• <b>If you have any interlocks</b>, check that they are in the ‘locked’ position, see “Landing Devices” supplementary manual.</li> </ul>
Lift runs normally, but interlocks will not unlock	<ul style="list-style-type: none"> <li>• Check that floor limit switches are activating. Note that the lower limit switch only activates when the load is removed from the drive.</li> <li>• <b>If you have a UPS</b>, check that the UPS is turned on.</li> </ul>
Lift won't raise full capacity and is vibrating and/or squealing when going down	<ul style="list-style-type: none"> <li>• Clean the guide rail surfaces using Simple Green cleaner</li> <li>• Clean and grease screw using Mobilith SHC 460PM</li> </ul>