

Staying Home Corporation

1503 Vine Street
P.O. Box 37
Harrisonville, MO 64701
816.380.2427
www.stayinghome.com



Legacy Installation Manual

I. PRELIMINARY CHECKS

A. INSTALLATION SITE REQUIREMENTS

- 115 VAC, 60 Hz, 3-wire grounded outlet within 6' of the top or bottom of the staircase
 - * Some states may require dedicated outlet
- Stair angle between 25° and 45°.
- Indoor installation.

B. INCLUDED WITH SHIPMENT

- Aluminum track w/ rack and splice bars
- (4-6) Track mounting brackets
- Chassis
- (2) Plastic cam / charge wire assemblies
- Footrest
- Seat
- Power supply transformer with 6' cord
- Header cover
- Upper and lower track end caps
- (2) Wireless call/send controls (remotes)
- Small parts bag
- Installation Manual
- Owner's Manual

C. TOOLS REQUIRED

(Italics indicate less common tool)

- Set of nut driver bits
- Set of screwdrivers (phillips)
- Tape measure
- 3/8" reversible drill w/8" extension
- Allen wrenches
- Portable band saw or hack saw
(for cutting stock track)
- Small level
- Combination wrench (7/16" & 1/2")
- Tools to remove handrail if interferes with the travel of the stairway lift.

II. TYPICAL COMPONENTS



- Legacy Classic seat assembly
- Classic stationary armrest
- Seatbelt with buckle on seat back
- Folding seat
- Unit control
- Footrest with safety pan

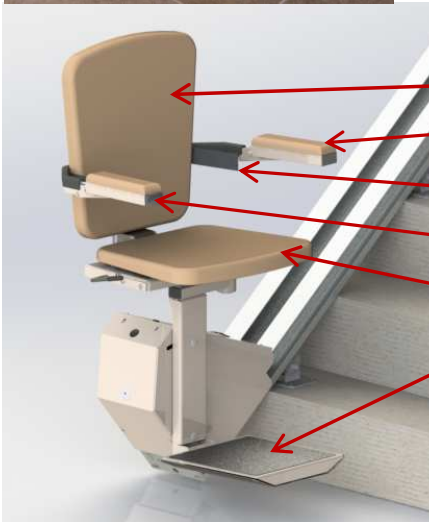

- Legacy Elegance seat assembly
- Elegance folding armrest
- Seatbelt with buckle on seat back
- Unit Control
- Folding Seat
- Footrest with safety pan

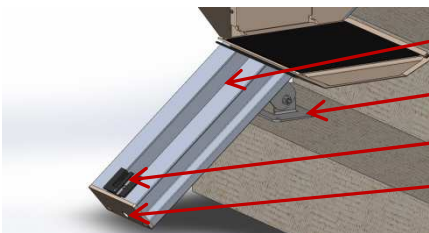

- Extruded aluminum track
- Track mounting bracket
- Stop & Charging cam
- Rail end cap

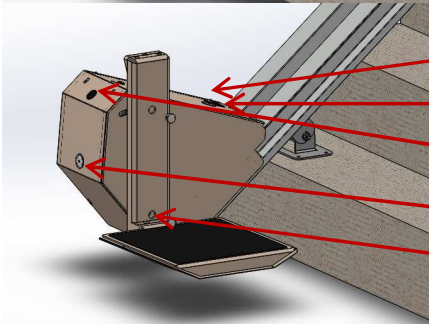

- Battery Shut-off/Rest switch
- Chassis Installation switch
- Manual lowering access port-hole
- Remote Control sensor
- Footrest assembly mounting bolts

Typical Gear Rack layout (16ft stock track shown)

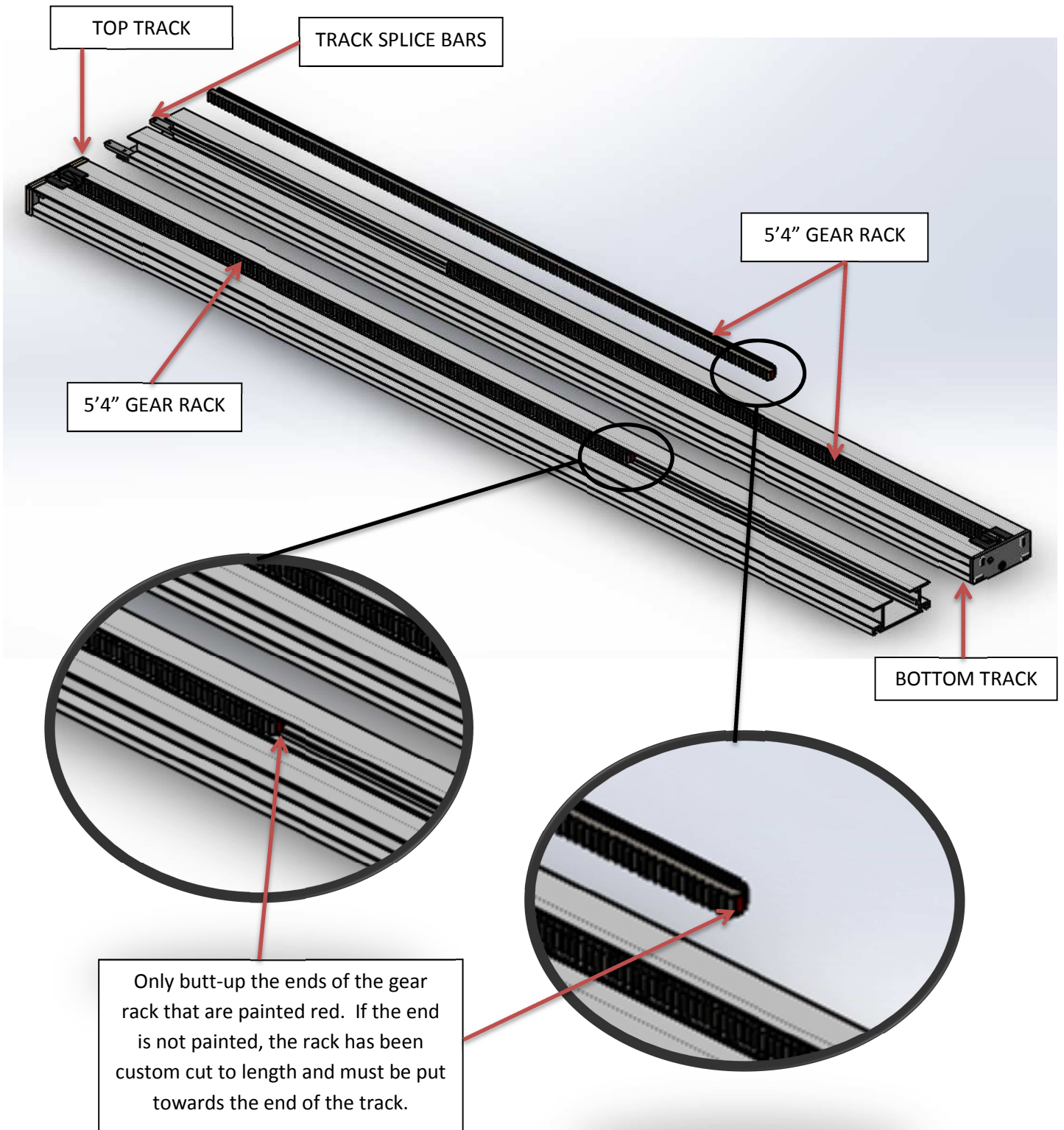

III. INSTALLATION PROCEDURES FOR STOCK UNITS:

TRACK INSTALLATION: Track and rack should be cut before installing them on stairs

Tracks are packaged in individual boxes. If you've receive a pre-installed unit, the bottom 48" track section is already mounted onto the chassis assembly. In total, you will generally have (2-3) sections of track with steel gear rack, (4-6) track mounting brackets located in a small parts box located in seat box, and (1-2) sets of splice bars already pre-mounted on the tracks.

Note: The upper and lower ends of the track sections are marked top & bottom. *The gear rack is already inserted in the gear rack channel of the track.*

- Look up the stairs and determine if the track is to be installed on the left side or right side. The gear rack should always be located on the right side of the track regardless of which side of the stairs the track is mounted.
- Measure the distance from the top nose of the staircase to the bottom floor & add 7" (*note; be sure to verify clearance from top nose to any obstruction at the top such as a door or door frame*

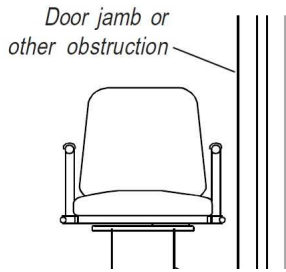

that would cause the chair to hit or block the seat from swiveling.) It may be necessary to ramp the track away from the obstruction, consult factory for assistance if needed.

- Cut the track at the top, leaving the factory cuts at all other sections. Cut the gear rack flush with the top of track.

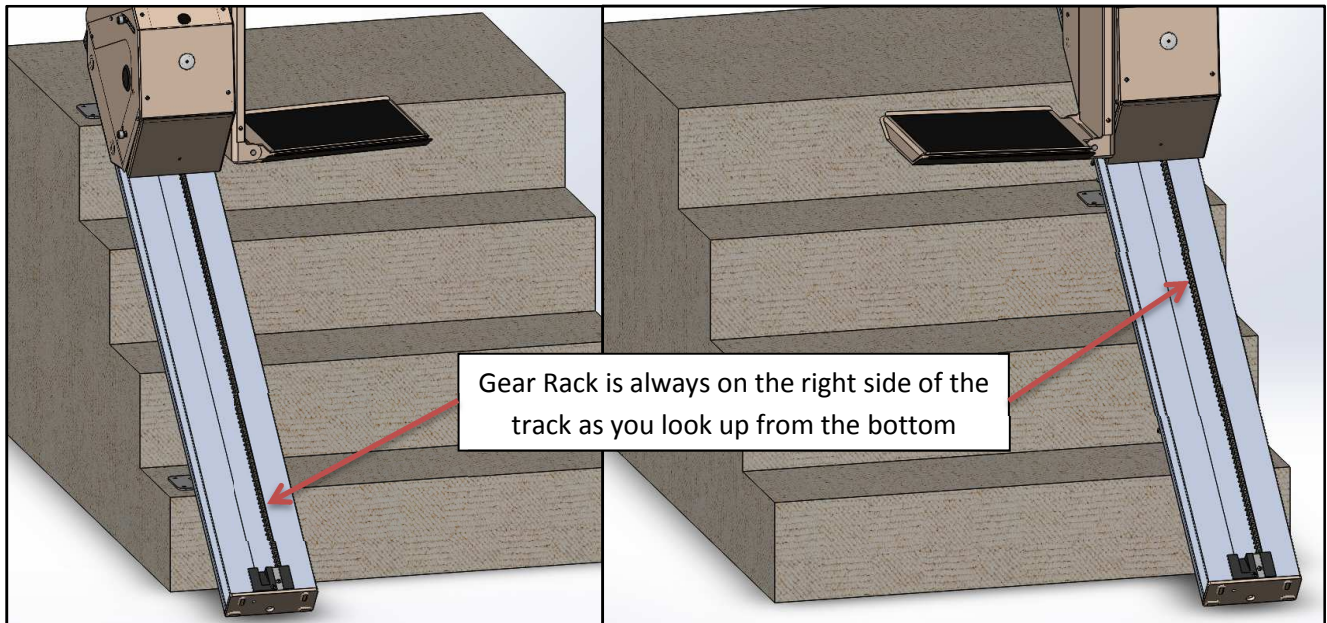

Track Splice Assembly

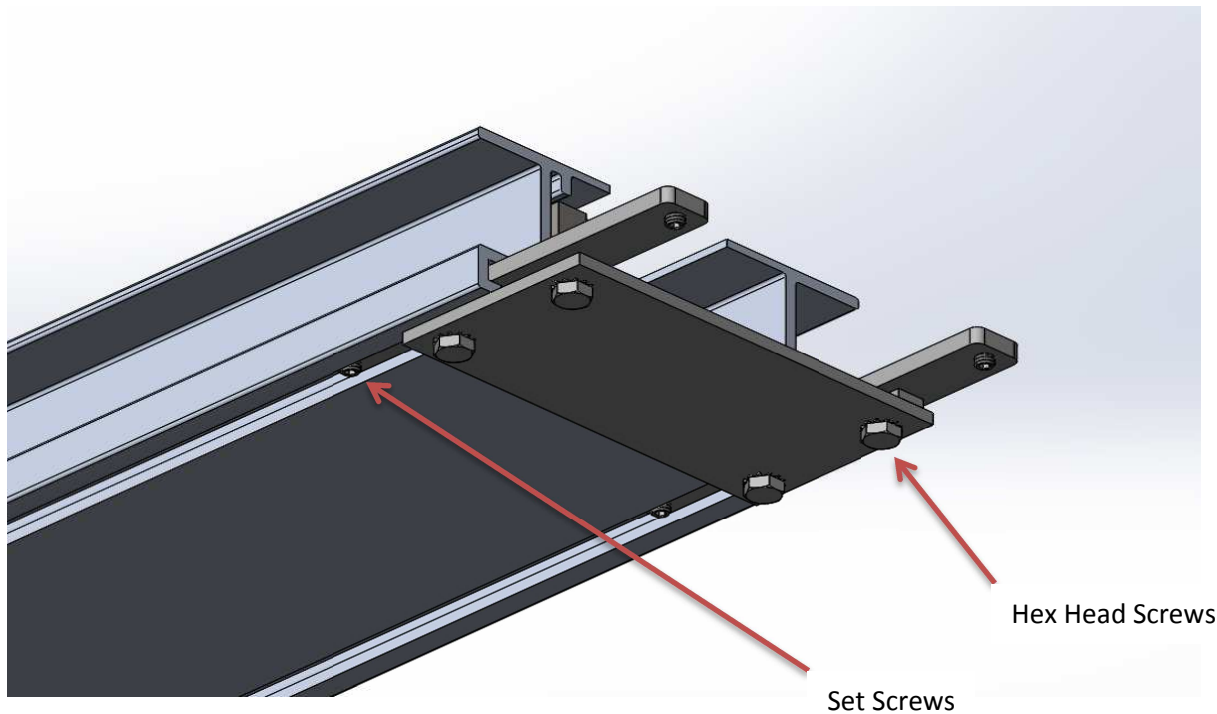

Aligning and securing the track splice.

Joining two pieces of track together is accomplished using a set of bars and splice plate.

- Check the edges of the outside C-channels for rough edges. If there are any burrs, file them off before splicing the track
- Position the splice so that is half way inserted into one track.
- Tighten the set screws in the bars
NOTE: There is a small insert bar on one side only of the splice bar that aligns the channels by fitting into the groove on the underneath side of the track.
- Slide the other track onto the splice ensuring that the track pieces align on all sides.
- Tighten the remaining set screws and the 4 hex head screws to lock everything together. Run your finger over the outer edges of the tracks to assure there are no significant edges protruding. If there are, separate the track slightly and realign as required to obtain a smooth transition between the track channels.

Secure the track to the stair treads using the supplied bracket assemblies.

Slide the upper “L” lip of the track bracket into the bottom track channels with the narrow portion of the “L” facing out towards the outer edges of the track.

Place one bracket on first tread, one on the top tread, and one bracket immediately above and below each splice. Then use the other brackets to support any section of track left unsupported and measuring greater than 48”.

NOTE: The track should be 2 ½” – 3” from the wall. The track brackets are made with a slight tilt to them so the track and seat leans backward slightly to offset the weight of the unit and user.

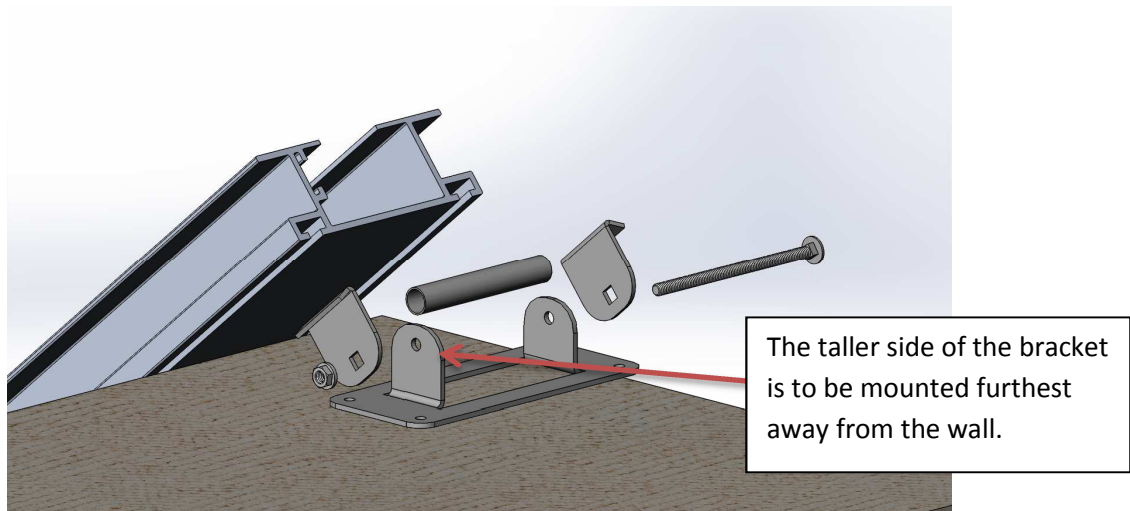

Position the track 2-3” from the wall or nearest obstruction & secure track brackets with wood screws provided, and tighten bracket bolts.

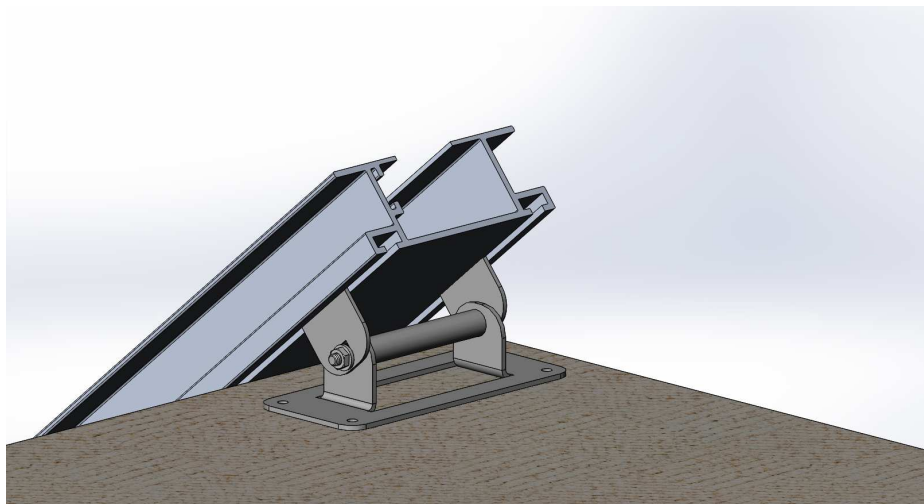

Inserting the chassis into the track

- Remove the upper most section of gear rack to allow you to slide the chassis into the track easily.
- Insure the rollers and spacers are properly installed on the chassis axle. **Failure to have the proper spacers in place will cause the pinion gear not to engage in the track rack properly.**
- Flip the RESET/OFF switch to the RESET position. The lift will beep and is now ready to be run down onto the gear rack using the black INSTALLTION SWITCH on top of the chassis. The lift may be ran to any desired position on the track to continue the installation.
- Attach the foot rest assembly to the chassis and plug in footrest wire plug. Pg. 8
- Attach the seat swivel post with three screws on the top of the footrest assembly Pg. 8
- Attach the seat plate onto the seat swivel using hardware as shown in drawing. Tighten the screw and washer onto the bottom of the Swivel Pin to prevent the seat from being able to be lifted off. Pg. 9
- Plug the Seat Switch control wire from the seat into the receptacle on the top of the chassis.
- Insert the seat proximity switch from the chassis into the plastic retainer on the Swivel Stop Plate. Insure the magnet on the swivel latch and the switch are no more than 1/4" apart. Pg. 9
- Turn on the red RESET/OFF switch to power up the chassis located on the top of chassis.
- Press and hold the arm control switch to run the chassis slightly down the track about 6".
- Verify there is minimum side to side play in the chassis and that the pinion gear is fully engaged in the track rack.
- Insert the top rack section previously removed.

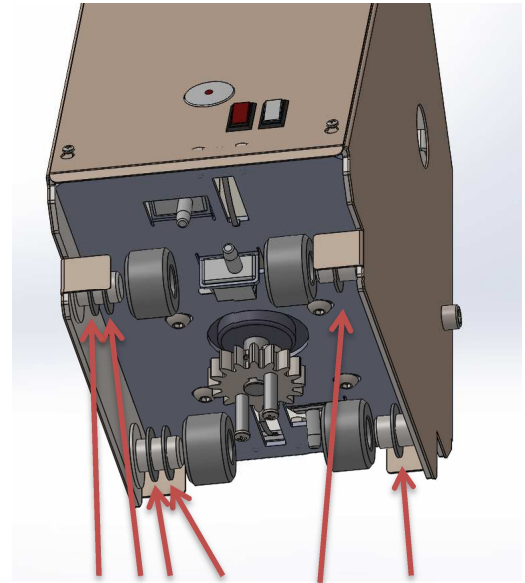

Ensure there are two plastic spacers behind chassis rollers on the gear rack side

Footrest Assembly on Chassis & Seat Swivel Screws

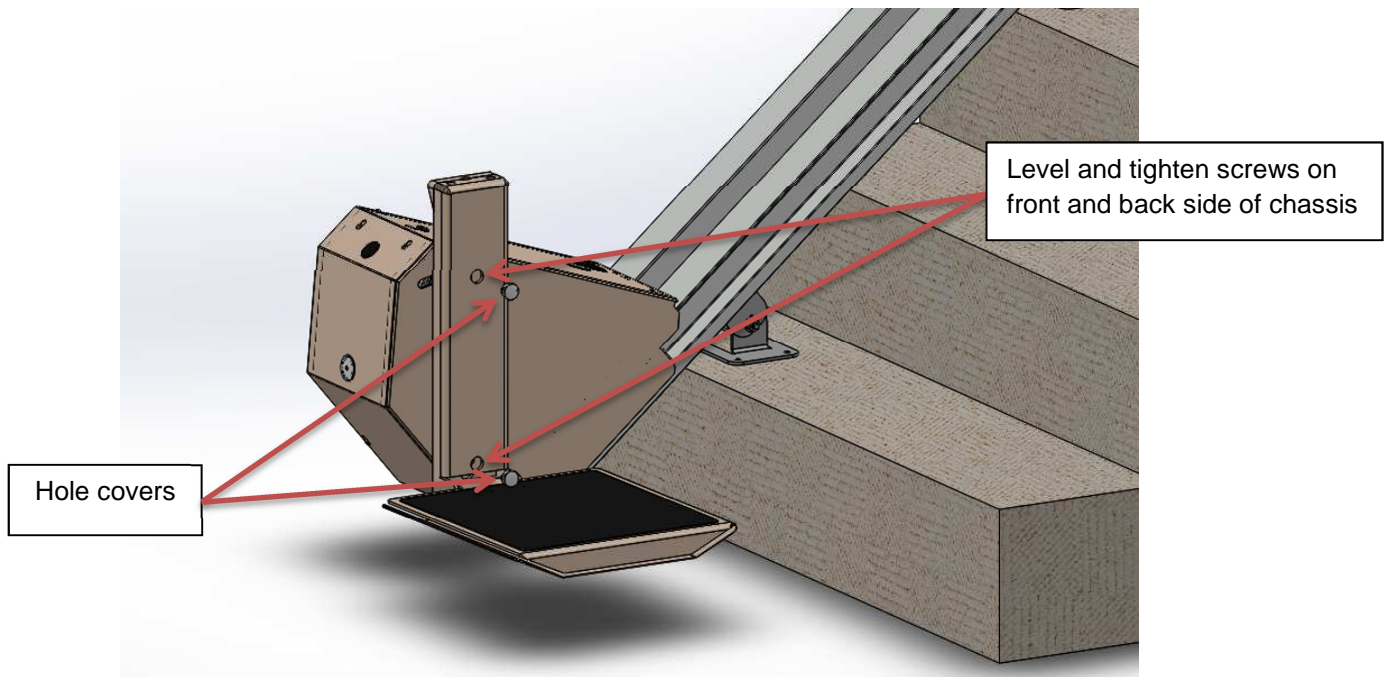

Seat Swivel Post

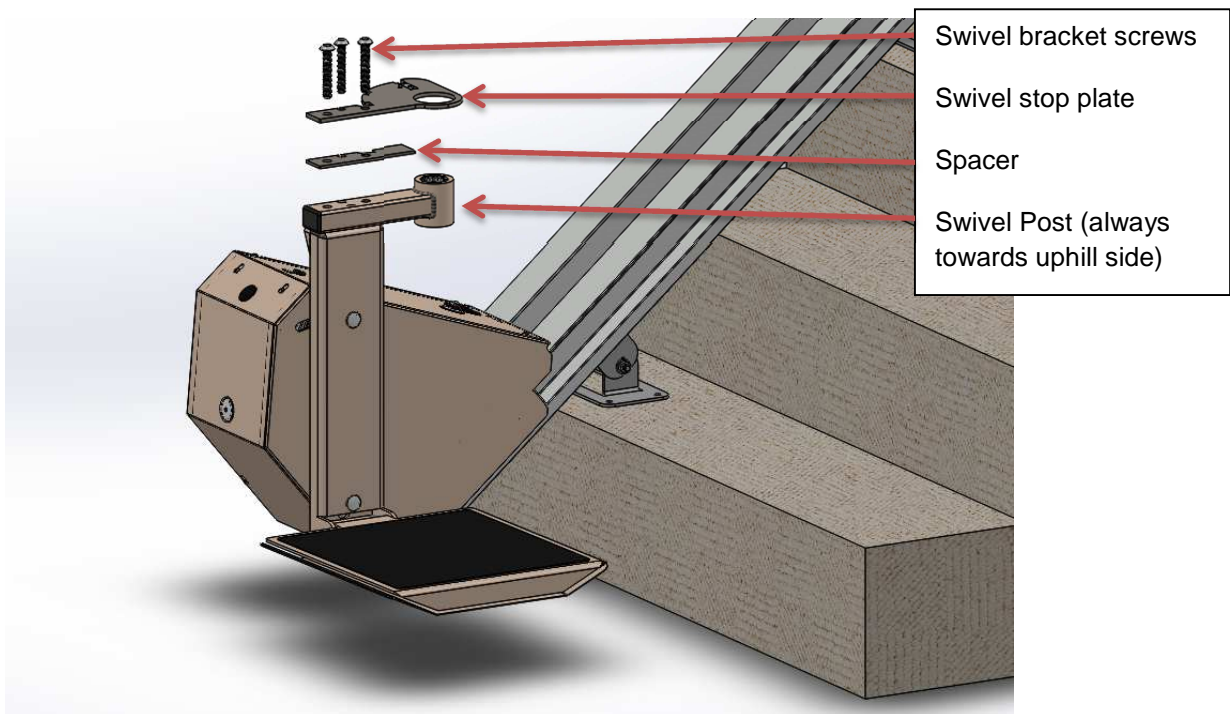

Seat Swivel Assembly

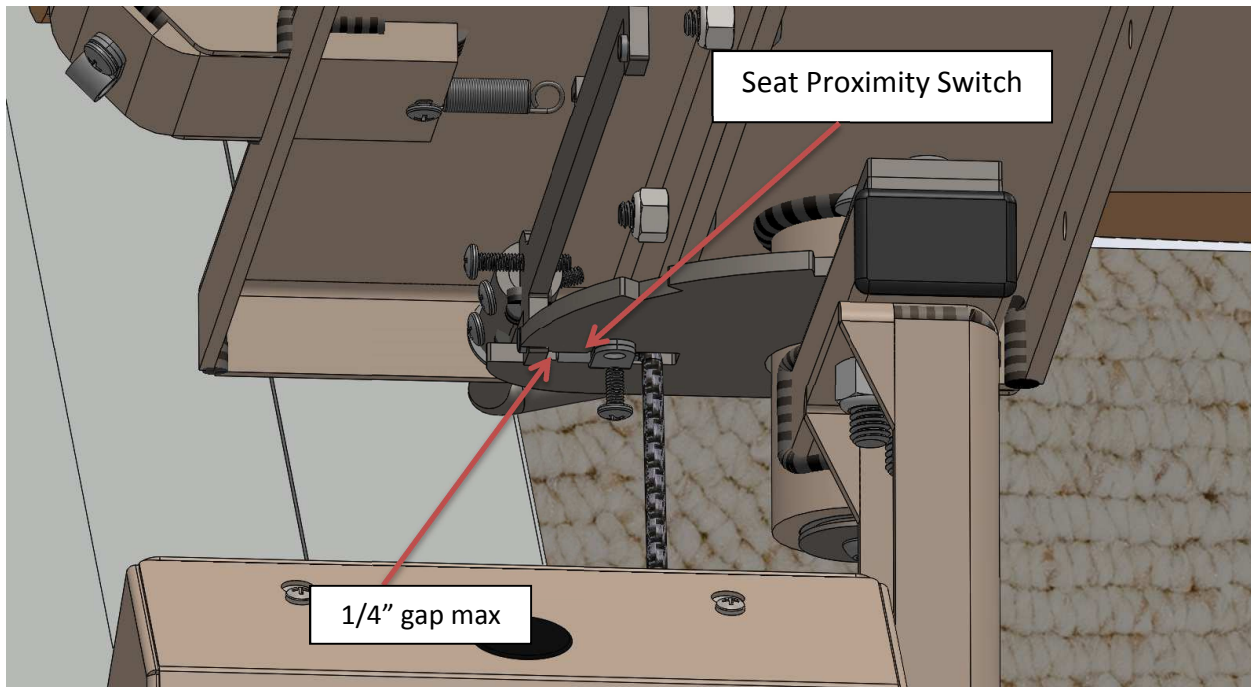
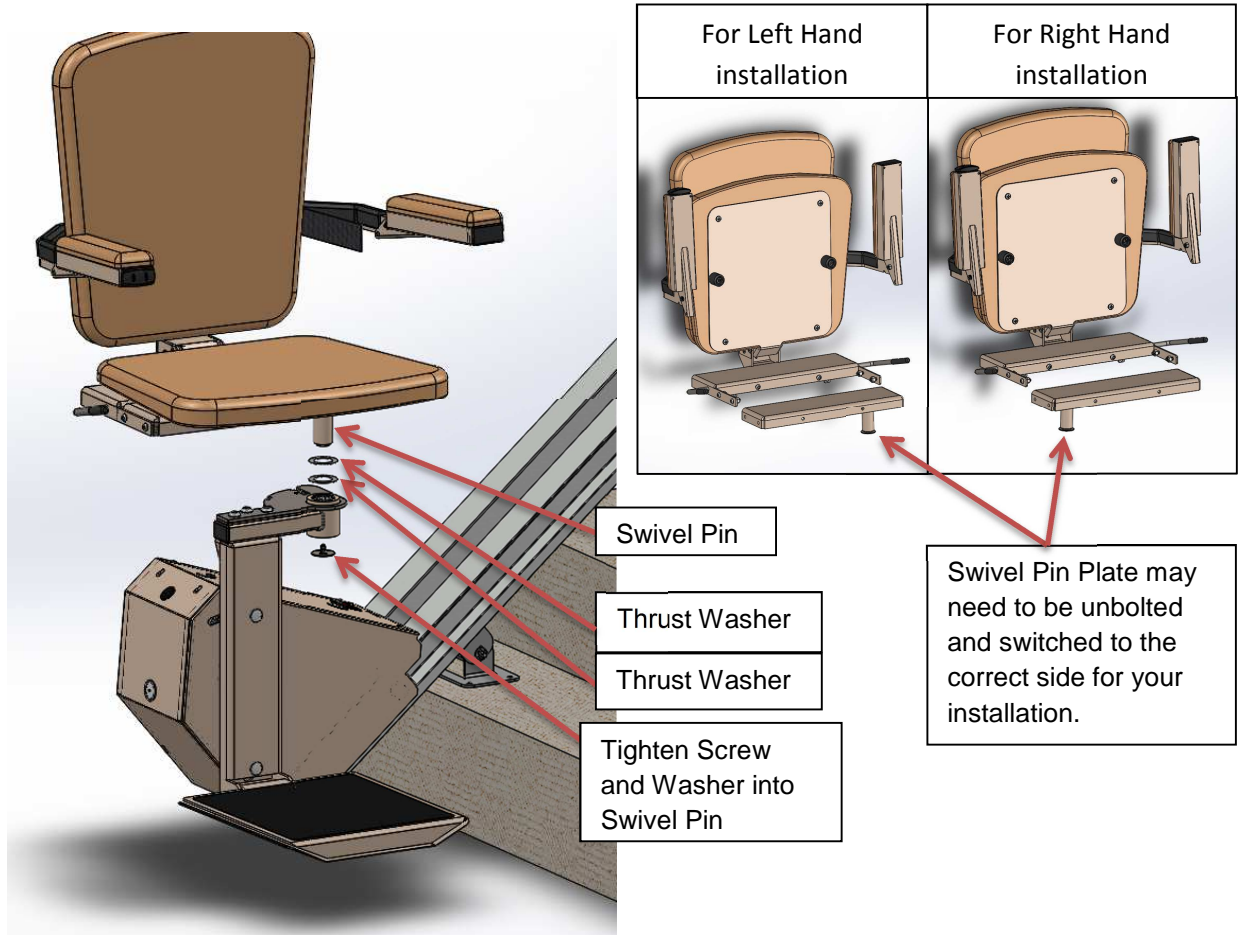

Attaching the Charge & Stop Cams and Top End Plate

- There are two cams with a short wire coming from the charge strip.
- The bottom track end plate is already attached – attach the top track end plate.
- Loosen the screw on the cams that goes into the support metal strip underneath the plastic cams.
- Route the charger wires through the track covers and neatly tuck underneath track on the wall side.
- Turn and slide the cams on the track and tighten screw to secure (ensure the cam is sitting flat on the track). You do not need to remove the track end plates to install the cams.
- Attach charge harness to both cams and the black ground wire to the Phillips head screw on the end plate or one of the track bracket mounting lags.
- Plug in charger to wall outlet.
- Adjust cams & charger strip to stop and charge properly. Test while riding in the chair & empty chair. Test at least 2 times at each station.

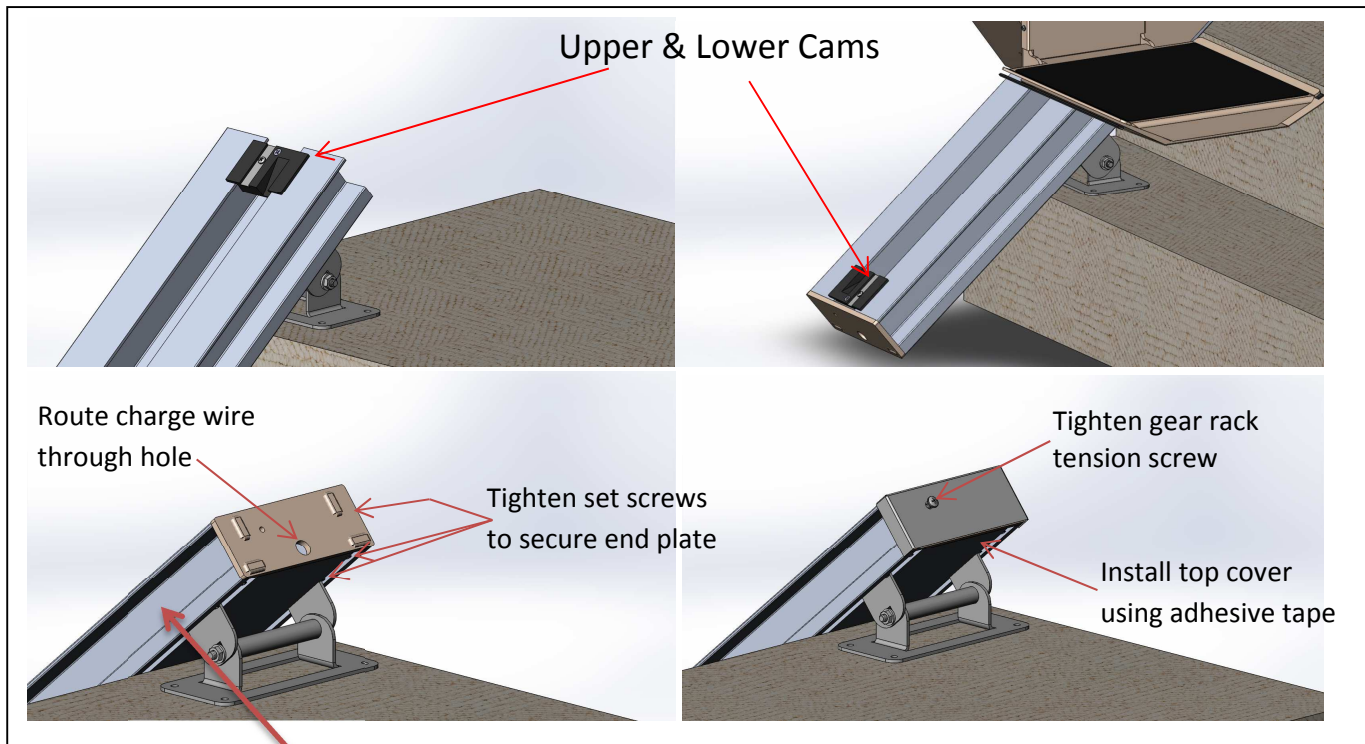

Apply a light coat of lithium grease on the two vertical surfaces of the track.

REMOTE CONTROL RE-PROGRAMMING

NOTE* The seat control switch takes precedent over the remote controls. After using the seat control there is a 20 second delay before the remote controls can be used.

All call/send controls are factory programmed. Re-programming is not normally necessary during installation. In the event that the remote call/send control needs to be re-programmed, it is essential to program BOTH controls in one programming cycle.

If needed, a different channel may be selected on the remotes by removing the left, right, or both jumpers. If changing channels, both remotes for the same lift must be set to the same channel.

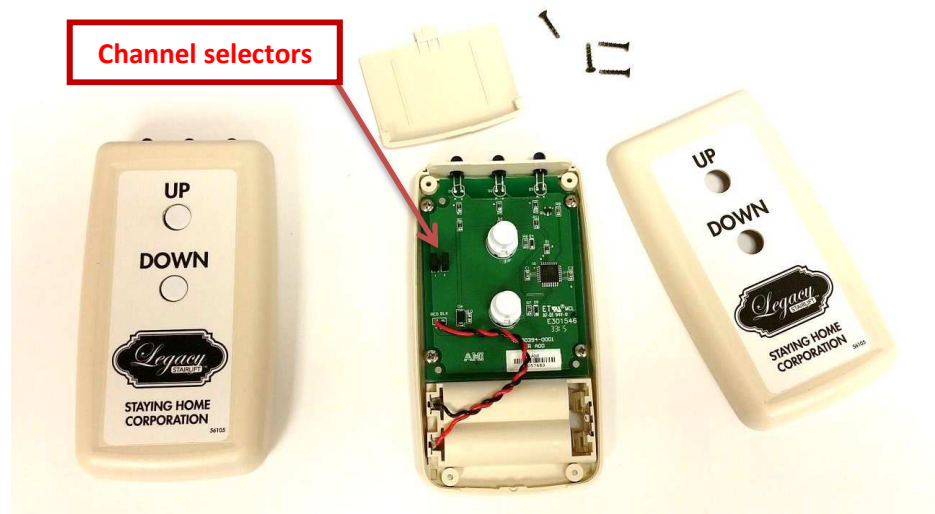

To reprogram the controller to the new remotes:

1. Start with the red ON/OFF switch in the OFF position (0).
2. Disconnect the 4-pin footrest harness and swivel the seat to open the seat swivel switch.
3. Press and hold the install switch (located on the top of the chassis) in either direction.
4. Turn the red RESET/OFF switch to the RESET position, and then release the install switch.
5. The lift will begin to beep rapidly, the controller is ready to “learn” the new remote signals.
6. Press and release the UP or DOWN button of the first remote control (the first remote control is now programmed).
7. Press and release the UP or DOWN button of the second remote control (the second remote control is now programmed). After learning the second remote, the lift will beep twice to indicate that both remote controls have been programmed.
8. Turn the REST/OFF switch to the OFF position.
9. Connect the 4-pin footrest harness and swivel the seat to the normal locked position, and then turn the red REST/OFF switch to the REST position.
10. Test each remote control in both the up and down directions.

AUDIO/VISUAL STATUS INDICATIONS

The lift is equipped with a chassis mounted 3-color LED display light to indicate the operating condition of the lift. Accompanying this is an audible alarm buzzer that will sound accordingly.

STATUS LIGHT	AUDIBLE ALARM	CONDITION
RED-YELLOW-GREEN-OFF-GREEN	1 SECOND BEEP	POWER-UP CYCLE
SOLID GREEN	NONE	READY TO OPERATE
YELLOW BLINK	1/4 SECOND BEEP (30 SECONDS)	NOT AT CHARGE POSITION (BEEPING REPEATS EVERY 10 MINUTES IF NOT MOVED TO CHARGE POSITION)
YELLOW PULSE	1/2 SECOND BEEP (5 MINUTES)	LOW BATTERY VOLTAGE (UNDER 22.5 VOLTS)
2 YELLOW FLASHES	1/2 SECOND BEEP	SEAT SWIVEL LATCH SENSOR
3 YELLOW FLASHES	1/2 SECOND BEEP	FOOTREST UPHILL OBSTRUCTION SENSOR
4 YELLOW FLASHES	1/2 SECOND BEEP	FOOTREST DOWNHILL OBSTRUCTION SENSOR
2 RED FLASHES*	3 SECOND BEEP	SENSOR FAULT (2 OR MORE SENSORS ENGAGED)
3 RED FLASHES*	3 SECOND BEEP	FINAL LIMIT
4 RED FLASHES*	3 SECOND BEEP	TRAVEL TIMEOUT (MOTOR RUNNING OVER 2-1/2 MINUTES)
YELLOW SOLID (30 SECONDS)	1/2 SECOND BEEP (30 SECONDS)	OVERLOAD (OVER 22 AMPS FOR 3 SECONDS)
RED SOLID (3 SECONDS)	3 SECOND BEEP	KEY TURNED OFF WHILE TRAVELING (OPTIONAL)
OFF (SLEEP)*	NONE	VERY LOW BATTERY VOLTAGE (UNDER 20.5 VOLTS FOR 5 MINUTES)

FLASH = 2 PER SECOND

BLINK = 1 PER SECOND

PULSE = 1 PER 10 SECONDS

*REQUIRES POWER TO BE CYCLED OFF/ON

IV. COMPLETION PROCEDURES

SERVICE LINE 877.378.4275
(Mon-Fri 8:00 – 5:00 CST)

COMPLETION CHECKLIST

The following features must be verified as operational before the Legacy stairway lift can be released for use:

_____ **Upper and lower limits:** Verify the lift stops automatically at the top and bottom of the track.

_____ **Upper and lower charge contacts:** Verify that the light on the charger changes from green when the lift stops at the upper and lower limit cams.

Status	Mode	Current	Voltage	LED Indication
Stage-1 De-sulphation	Pulse Mode	Pulse Current	Increasing	RED Solid
Stage-2 Bulk Charging	CC Mode	Rated Current	Increasing up to cut-off	ORANGE Solid
Stage-3 Cell Equalization	CV Mode	Decreasing to 30% rated Current	Cut-off Volts	ORANGE Solid
Stage-4 Float Voltage	CV Mode	To Cover Losses	Float Volts	GREEN Solid

_____ **Running Clearance:** Verify the lift clears all obstructions.

_____ **Unit Control:** Verify control functions in both directions.

_____ **Call/Send Remotes:** Verify both call/send controls operate the lift up and down in the appropriate direction.

Track:

_____ **IMPORTANT: Top Track End Plate:** It is imperative the 6 small set screws under the top track end plate are very tight.

_____ **IMPORTANT: Lower Track End Plate:** It is imperative the 6 small set screws under the lower track end plate are very tight.

_____ **Track Mounting Brackets:** Verify all track mounting brackets are securely attached to the stair treads, the track and at the pivot points.

_____ **Track Splice:** Verify track joints are smooth and free of burrs and gaps.

_____ Verify the rack tension screw is tight

_____ Verify chassis gear and rack is tight and no excess play.

_____ Check to insure the chassis axle is not rubbing track

_____ Verify the gear rack is sufficiently lubricated – a light coat of lithium or other all-purpose grease is acceptable

_____ Verify the top track cover is securely fastened to the track.

_____ Verify the inside of the track is free of foreign objects.

Footrest:

_____ Verify the footrest is level.

_____ Verify the footrest clears all stair nose.

_____ Verify the lift stops when the footrest runs into an obstruction.

_____ Verify the lift will run when you reverse directions of the switch when the footrest is obstructed in the opposite direction.

_____ Verify the footrest folds up and stays in the up position.

Seat:

_____ Verify the seat is level and securely fastened.

_____ Verify seatbelt & buckle will are secure and function.

_____ Verify the seat swivels 45° and 85° toward the upper landing and locks into position.

_____ Verify the lift will not operate when the seat is not locked in the riding position.

_____ Verify the seat will fold up and stay in the up position.

_____ Verify both arms will fold up and stay in the up position. (ELEGANCE model only)

_____ **Clean Up:** Verify the stairway lift has all grease, dirt, etc. cleaned off.

BEFORE LEAVING THE JOBSITE

_____ Clean up work area.

_____ Assist customer on how to use the unit and ride it properly.

_____ Demonstrate proper operation, seatbelt use, lubrication and maintenance procedures to the user of the lift and other family members at the residence.

_____ Give customer a copy of the Owner's Manual for reference. Please take time to insert your business card or write your company name, address and telephone number inside the Owner's Manual in the area provided.

NOTES: _____