

4

3

2

1

**TYPICAL DRAWINGS
VPL UNENCLOSED NO PIT
ADJ/90° EXIT PLATFORM**

REVISIONS				
REV.	DESCRIPTION	BY	CHK	DATE
A	INITIAL RELEASE, ECO-005013	CJP	DN	16APF20

PRODUCT SPECIFICATIONS

RATED LOAD:	750 LBS (340 KG) MAXIMUM
INPUT POWER SOURCE:	
-AC POWERED UNIT:	110-120 VAC, 20 AMP, 60 HZ DEDICATED SERVICE
-OPT BATTERY BACKUP UNIT:	BASE 2X 12 V BATTERIES (NOT AVAILABLE FOR VPL800-1400) PLUS 4X 12 V BATTERIES
DRIVE:	
-AC POWERED UNIT:	2/3 HP, 26:1 GEARMOTOR W/BRAKE, 90 VDC, INTERMITTENT DUTY, CLASS H
DRIVE:	1" DIAMETER, 0.1" PITCH, 10 START ACME SCREW (1" LEAD)
LIFT SPEED:	7-10 FEET/MINUTE
SAFETY:	MOTOR FRICTION BRAKE AND ELECTRIC BRAKE, OVERSPEED GOVERNOR, BACKUP ACME NUT, SAFETY PAN, E-STOP, OVERLOAD SENSING, OVER TEMPERATURE SENSING, PERFORMANCE MONITORING, BATTERY MONITORING (ON BATTERY BACKUP UNITS)

FOR COMPLETE TECHNICAL SPECIFICATIONS, REFER TO HARMAR DOCUMENT MKT-000126.
SPECIFICATIONS SUBJECT TO CHANGE WITH OR WITHOUT NOTICE.

DESIGN AND REGULATORY REQUIREMENTS

USA FOOD & DRUG ADMINISTRATION: CLASS II, 510(K) EXEMPT FILE NO. 890.3930, PRODUCT CODE: PCE

DESIGNED IN COMPLIANCE WITH THE FOLLOWING CODES:

- ASME A18.1 SAFETY STANDARD FOR PLATFORM LIFTS AND STAIRWAY CHAIRLIFTS (SECTIONS 2 AND 5)
- CSA B44.1/ASME A17.5 ELEVATOR AND ESCALATOR ELECTRICAL EQUIPMENT
- ICC ANSI A117.1 ACCESSIBLE AND USABLE BUILDINGS AND FACILITIES
- NFPA 70 NATIONAL FIRE PROTECTION AGENCY - NATIONAL ELECTRICAL CODE
- ETL CERTIFIED - CONTROL NUMBER 3148125

FDA INDICATION OF USE STATEMENT

THE HIGHLANDER II VERTICAL PLATFORM LIFT IS TO ASSIST IN THE TRANSFER OF PATIENTS OR A MOBILITY IMPAIRED PERSON, UP AND DOWN BETWEEN LEVELS OF A RESIDENTIAL OR COMMERCIAL FACILITY.

<small>CONFIDENTIAL INFORMATION NOT TO BE COPIED OR USED WITHOUT WRITTEN CONSENT. INTERPRET DRAWING AND TOL PER ASEM Y14.5 - 2009</small>		
	DWG NO. ENG-000842	REV A
UNLESS OTHERWISE SPECIFIED DIMENSIONS ARE IN INCHES. TOLERANCES ARE: DECIMALS .X = ±0.1 .XX = ±0.02 .XXX = ±0.010 HOLE DIA'S = ±.005 ANGLES = ±1° <small>DO NOT MEASURE FROM DRAWING</small>	DESCRIPTION TYPICAL DRAWINGS VPL UNENCLOSED NO PIT ADJ/90° EXIT PLATFORM	
	DRAWN BY C POLSTER	DATE 17FEB20
	SCALE NTS SIZE: B	SHEET 1 OF 4

8

7

6

5

4

3

2

1

**TYPICAL DRAWINGS
VPL UNENCLOSED NO PIT
ADJ/90° EXIT PLATFORM**

REVISIONS				
REV.	DESCRIPTION	BY	CHK	DATE
-	See Sheet1	-	-	-

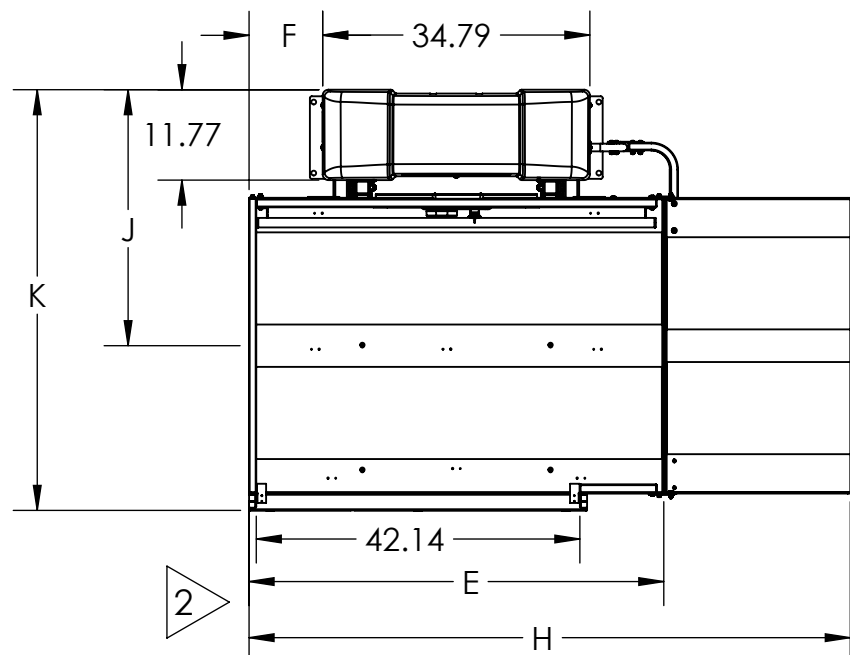

RIGHT HAND UNIT SHOWN

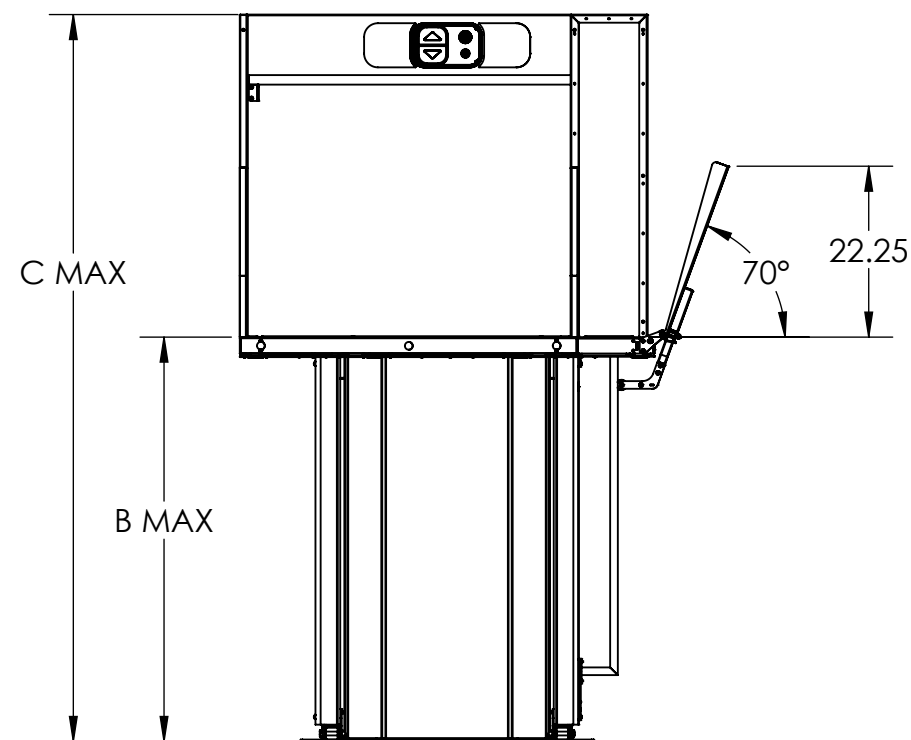
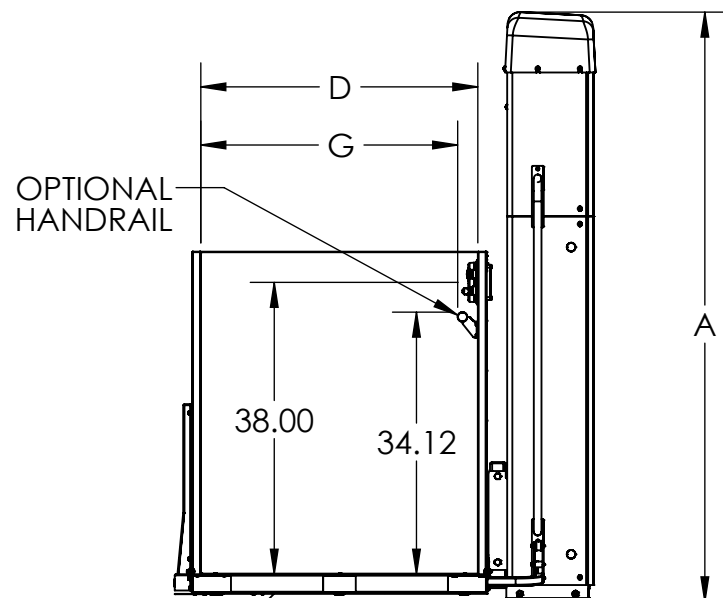
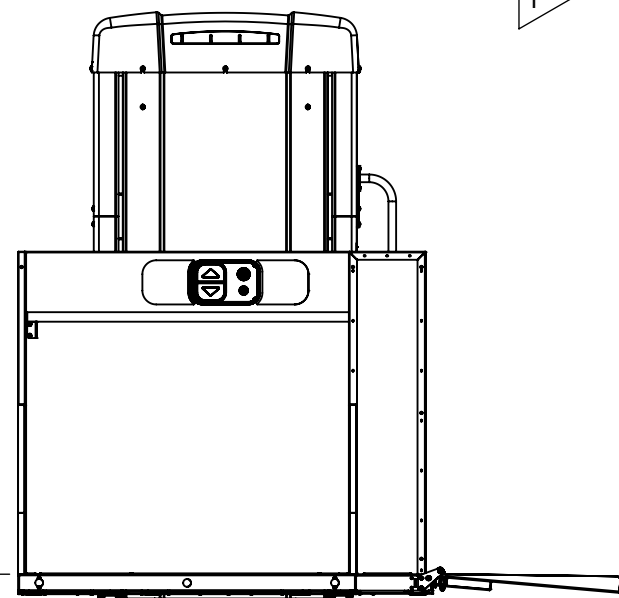

NOTES:

- 1 BOTH RIGHT AND LEFT HAND PLATFORMS AVAILABLE
- 2 PLATFORM GATE ADDS 1.50" TO DIMENSIONS E & H
- 3 ASME A18.1 REQUIRES COMMERCIAL LIFTS OVER 60" TRAVEL TO BE IN AN ENCLOSED HOISTWAY.

PLATFORM	D	E	F	G	H	J	K
36" X 54"	36.00	54.00	9.60	33.44	78.4	33.33	54.78
36" X 60"	36.00	62.00	13.60	33.44	84.4	33.33	54.78
42" X 54"	42.00	54.00	9.60	39.44	78.4	36.33	60.78
42" X 60"	42.00	62.00	13.60	39.44	84.4	36.33	60.78

LIFT MODEL	A	B	C
VPL400	77	53	95
VPL600	101	77	119
VPL800	125	101	143
VPL1000	149	125	167
VPL1200	173	149	191
VPL1400	197	171	213

CONFIDENTIAL INFORMATION
NOT TO BE COPIED OR USED
WITHOUT WRITTEN CONSENT.
INTERPET DRAWING AND TOL
PER ASEM Y14.5 - 2009

UNLESS OTHERWISE SPECIFIED
DIMENSIONS ARE IN INCHES.
TOLERANCES ARE:

DECIMALS .X = ±0.1
.XX = ±0.02
.XXX = ±0.010

HOLE DIA'S = ±0.005

ANGLES = ±1°

DO NOT MEASURE FROM DRAWING



DWG NO. **ENG-000842** REV **A**

DESCRIPTION
**TYPICAL DRAWINGS VPL UNENCLOSED
NO PIT ADJ/90° EXIT PLATFORM**

DRAWN BY		DATE	
C POLSTER		17FEB20	
SCALE NTS	SIZE: B	SHEET 2 OF 4	

**TYPICAL DRAWINGS
VPL UNENCLOSED NO PIT
ADJ/90° EXIT PLATFORM**

REVISIONS				
REV.	DESCRIPTION	BY	CHK	DATE
-	See Sheet1	-	-	-

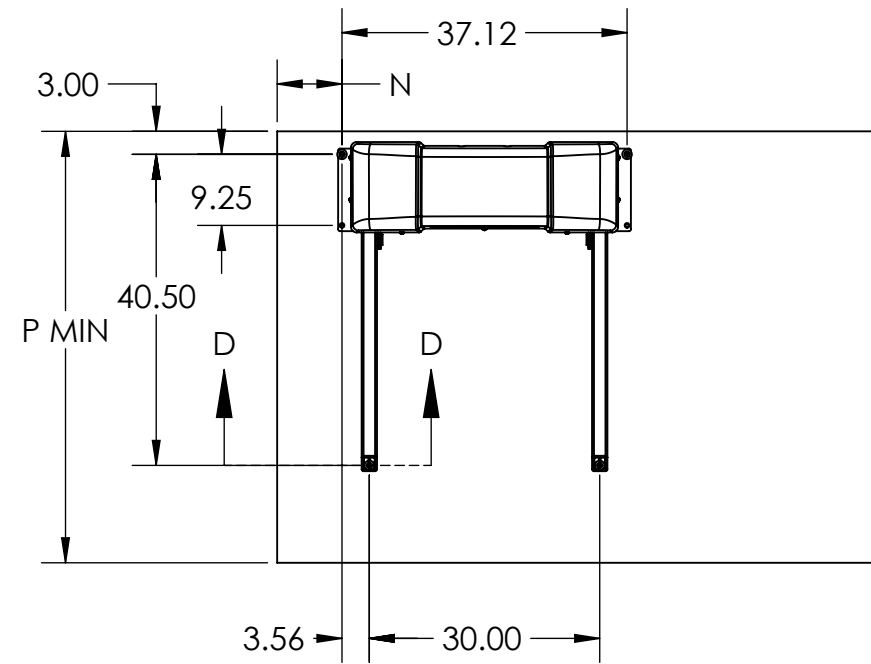

PAD DETAILS

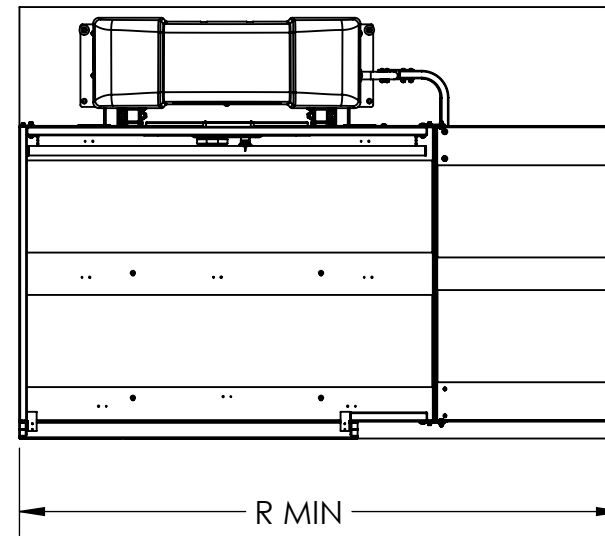

LIFT WITH AUTO RAMP

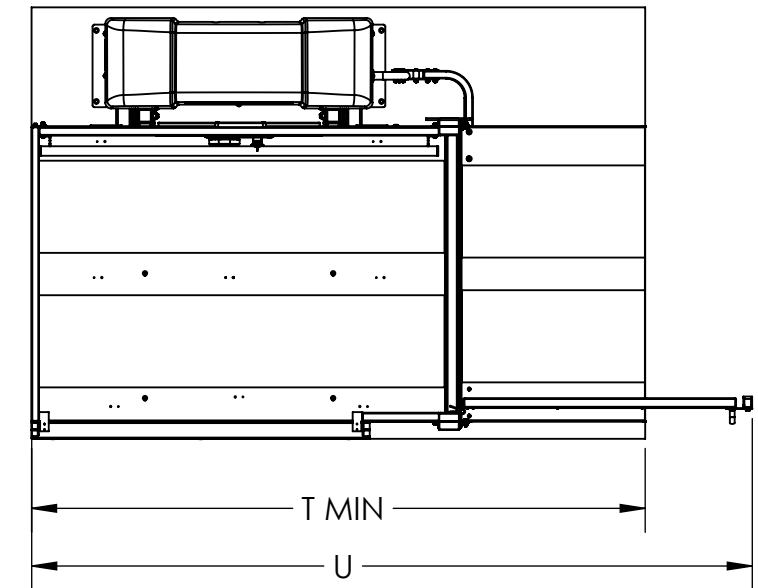

LIFT WITH GATE AND AUTO RAMP

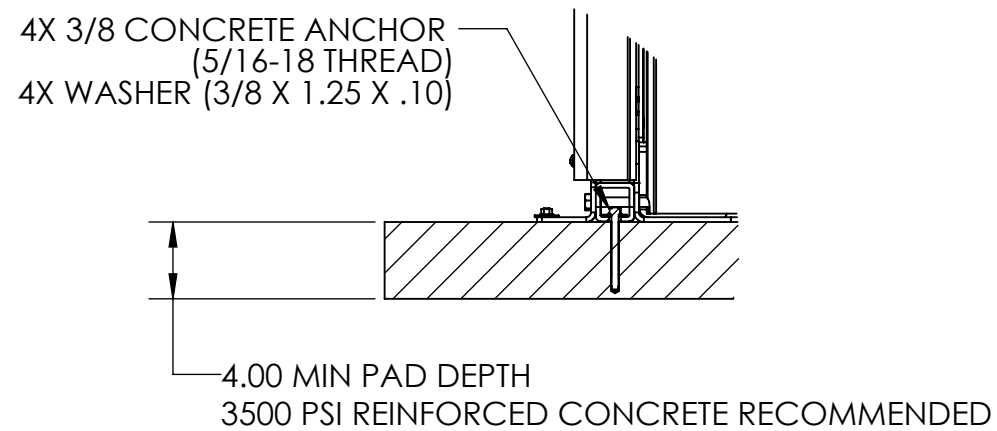

**SECTION VIEW
OF CONCRETE ANCHORS
(NOT TO SCALE)**

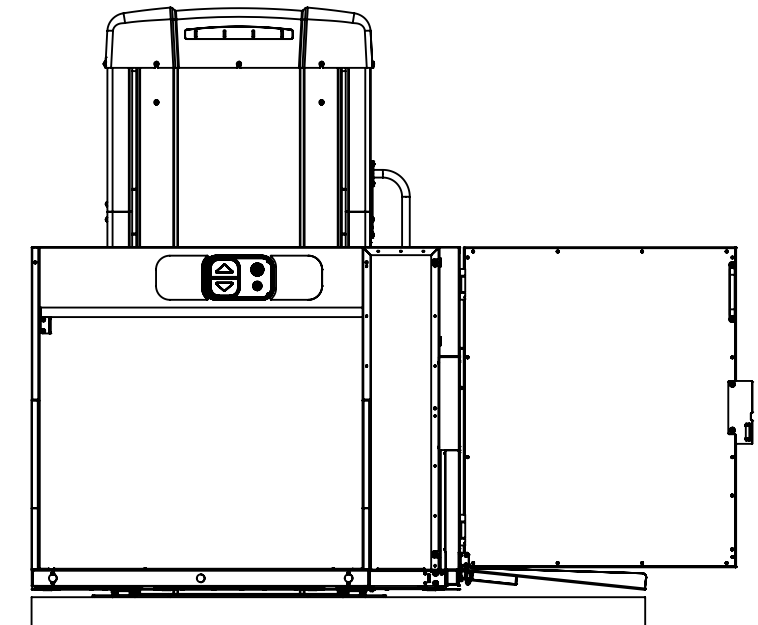
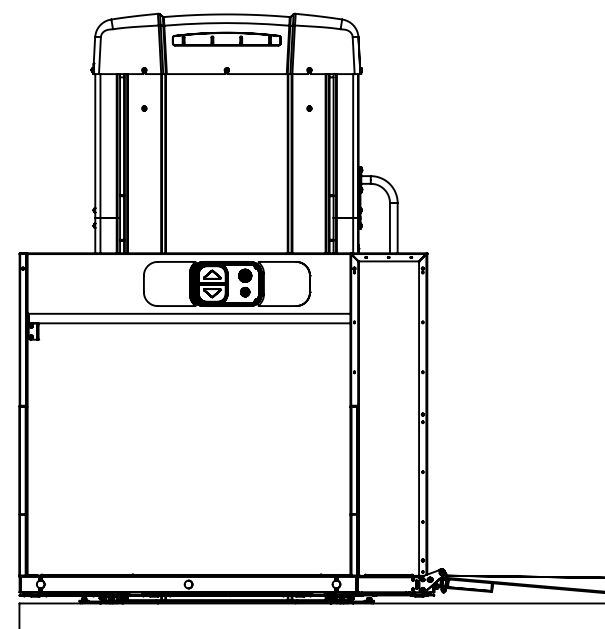

PAD DIMENSIONS MINIMUM					
PLATFORM	N	P	R	T	U
36" X 54"	8.44	56.18	78.4	79.9	93.82
36" X 60"	12.44	56.18	86.4	87.9	101.82
42" X 54"	8.44	62.18	78.4	79.9	99.82
42" X 60"	12.44	62.18	86.4	87.9	107.82

CONFIDENTIAL INFORMATION
NOT TO BE COPIED OR USED
WITHOUT WRITTEN CONSENT.
INTERPET DRAWING AND TOL
PER ASEM Y14.5 - 2009



UNLESS OTHERWISE SPECIFIED
DIMENSIONS ARE IN INCHES.
TOLERANCES ARE:

DECIMALS .X = ±0.1
.XX = ±0.02
.XXX = ±0.010

HOLE DIA'S = ±.005

ANGLES = ±1°

DO NOT MEASURE FROM DRAWING

DWG NO. **ENG-000842** REV **A**

DESCRIPTION
**TYPICAL DRAWINGS VPL UNENCLOSED
NO PIT ADJ/90° EXIT PLATFORM**

DRAWN BY C POLSTER		DATE 17FEB20
SCALE NTS	SIZE: B	SHEET 3 OF 4

4

3

2

1

**TYPICAL DRAWINGS
VPL UNENCLOSED NO PIT
ADJ/90° EXIT PLATFORM**

REVISIONS				
REV.	DESCRIPTION	BY	CHK	DATE
-	See Sheet1	-	-	-

2X 530-00946 TOWER BRACE SUPPORT
(INSIDE TOWER BETWEEN
CROSS BRACE AND REAR PANEL)

2 X 10 OR SIMILAR BACKING
(INSTALLER SUPPLIED)

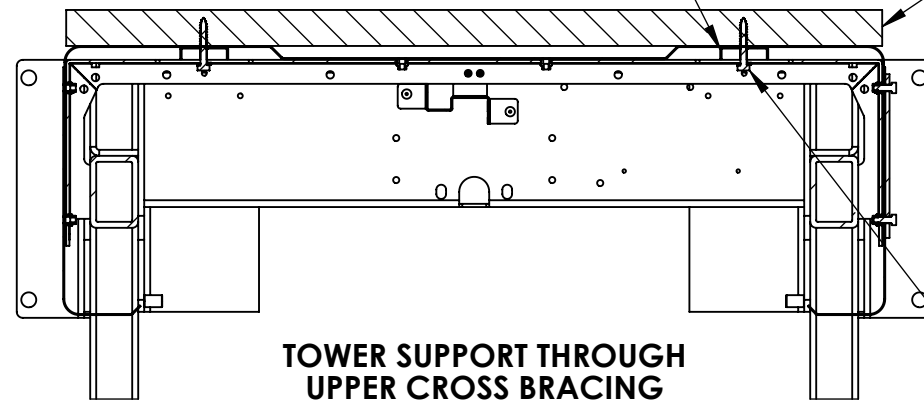

**TOWER SUPPORT THROUGH
UPPER CROSS BRACING**

4X 5/16X2.00 LAG SCREWS
4X 5/16 LOCK WASHERS
(INSTALLER SUPPLIED)
(PRE-DRILL 11/32 HOLES
IN TOWER PANELS FOR
LAG SCREWS)

Site Construction Details

Electrical Requirements:

Check NFPA 70 and all applicable codes for all electrical and wiring requirements.

Platform Pathway Requirements:

Ensure the platform pathway is sufficiently illuminated, clear of any electrical conduit and wireways and there is sufficient headroom clearance (minimum of 79"-2007mm) per ASME A18.1 throughout floor-to-floor travel.

Floor Recommendations:

A 4" (102mm) thick, 3500 PSI minimum compressive strength, reinforced concrete pad is recommended. Refer to sheet 3 for minimum pad dimensions.

Tower Floor Anchoring:

VPL must be fastened to concrete pad using a minimum of four (4) 3/8" (5/16" bolt) x minimum 2-1/2" long concrete anchors suitable for the environment. Refer to Pad Details on sheet 3 for mounting hole locations. Follow selected concrete anchor manufacturer's guidelines and all applicable codes.

Tower Support:

Tower support is not required on lifts with travel under 8 feet. Lifts with travel of 8 feet or more are required to be supported appropriately. See views at left or installation manual for more details.

Top Landing Gate Attachment:

Refer to landing gate detail pages.

Platform to Top of Landing Sill Clearance:

ASME A18.1 code stipulates the platform-to-sill clearance at the upper landing shall not be less than 3/8" (9.5mm) nor exceed 3/4" (19.1mm). Follow all applicable codes.

Fascia Wall Requirements:

ASME A18.1 code stipulates that fascia should be smooth and/or non-perforated that guards the full length and width of the platform. The fascia shall be securely fastened from the upper landing sill down to ground level. The fascia must be able to support a 125-pound side load over any 4-inch square area. Follow all applicable codes.

B

B

A

A

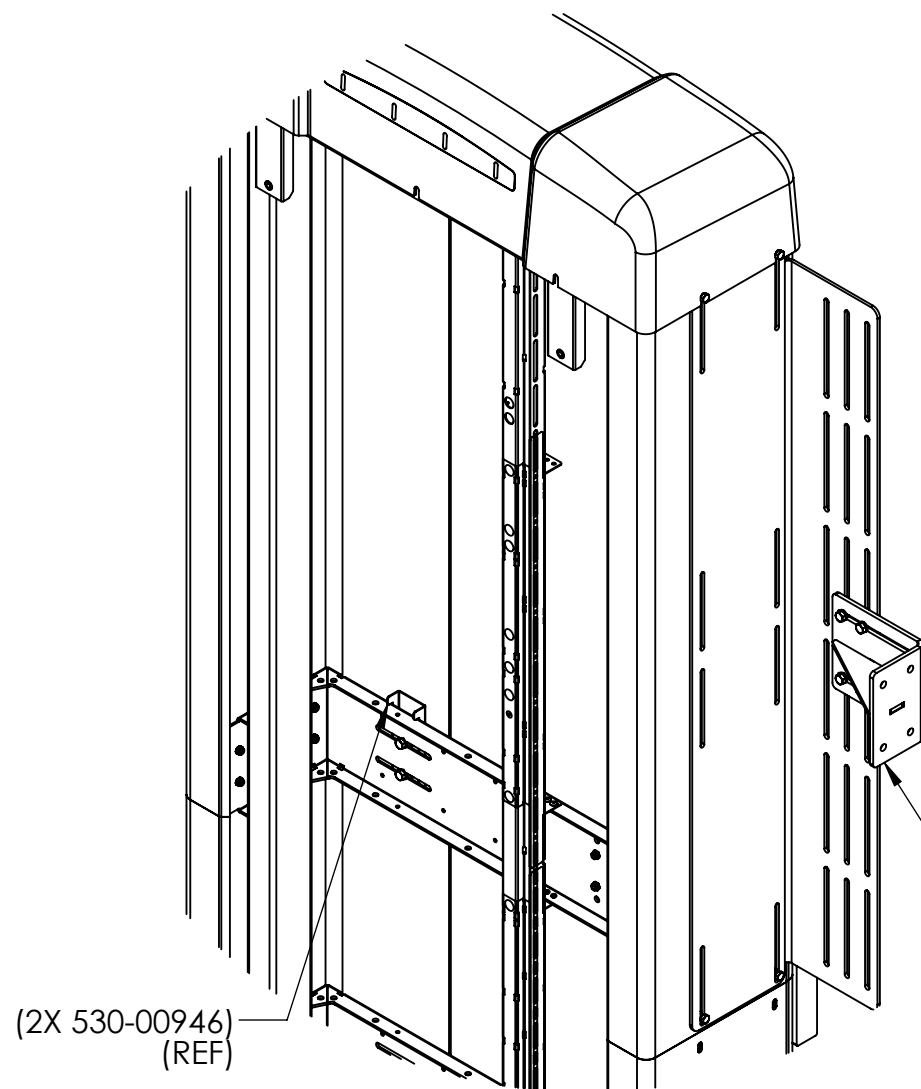

(2X 530-00946)
(REF)

**TOWER SUPPORT FROM
SIDE OF TOWER TO STRUCTURE**

140-00148 TOWER BRACE KIT (48/54L PLTFM) OR
140-00149 TOWER BRACE KIT (54/60L PLTFM)
(INCLUDES HARDWARE SHOWN)

8

7

6

5

4

3

2

1

<small>CONFIDENTIAL INFORMATION NOT TO BE COPIED OR USED WITHOUT WRITTEN CONSENT. INTERPRET DRAWING AND TOL PER ASEM Y14.5 - 2009</small>		
	DWG NO. ENG-000842	REV A
<small>UNLESS OTHERWISE SPECIFIED DIMENSIONS ARE IN INCHES. TOLERANCES ARE:</small>	DESCRIPTION TYPICAL DRAWINGS VPL UNENCLOSED NO PIT ADJ/90° EXIT PLATFORM	
DECIMALS .X = ±0.1 .XX = ±0.02 .XXX = ±0.010	DRAWN BY C POLSTER	DATE 17FEB20
HOLE DIA'S = ±.005 ANGLES = ±1°	SCALE NTS SIZE: B	SHEET 4 OF 4
<small>DO NOT MEASURE FROM DRAWING</small>		