

Owner's Manual

TriFlo Spa Bath Pump

Diagram 1 Correct Spa Bath Pump Installations

Use 40mm or 25mm UPVC Pressure Pipe for plumbing installation, 40mm pipe is preferred for both the suction and return lines.

IMPORTANT REQUIREMENT FOR PUMP SERVICE:

- Pump installation must provide reasonable access for pump removal.
- To allow for pump removal a serviceman must be able to reach the barrel unions.
- Under hob installation- an access panel must be provided on every installation.

Standard Installation

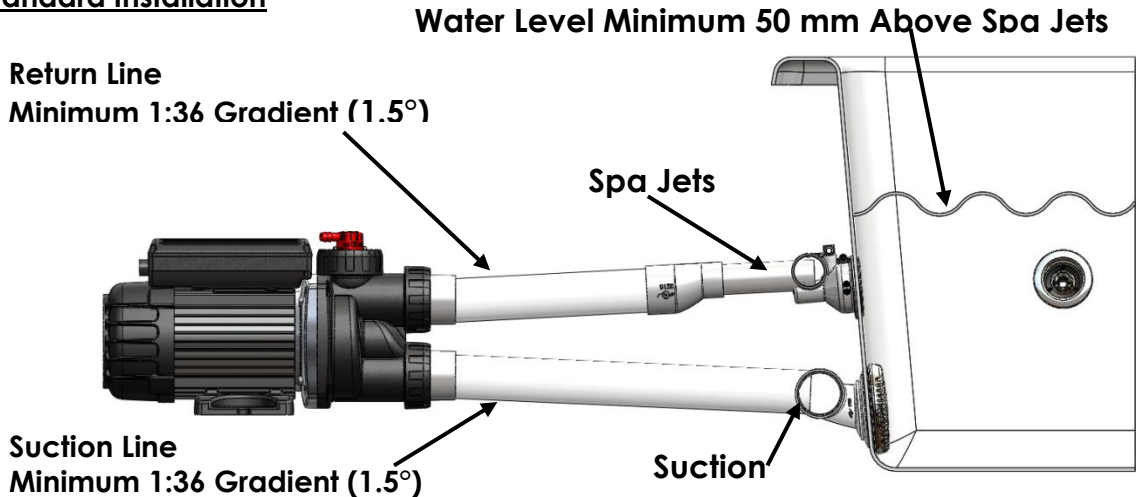

Top Outlet Installation-Please note the Air Bleed cannot be activated in this installation.

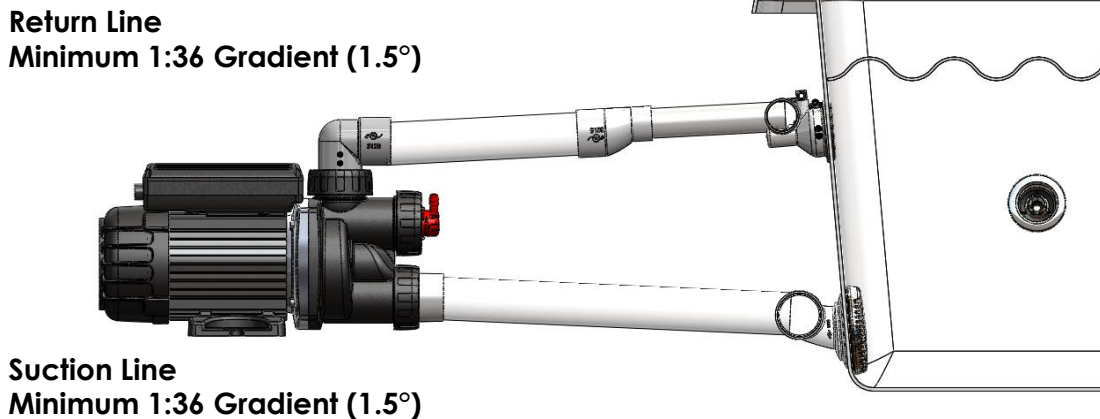

TriFlo Installation

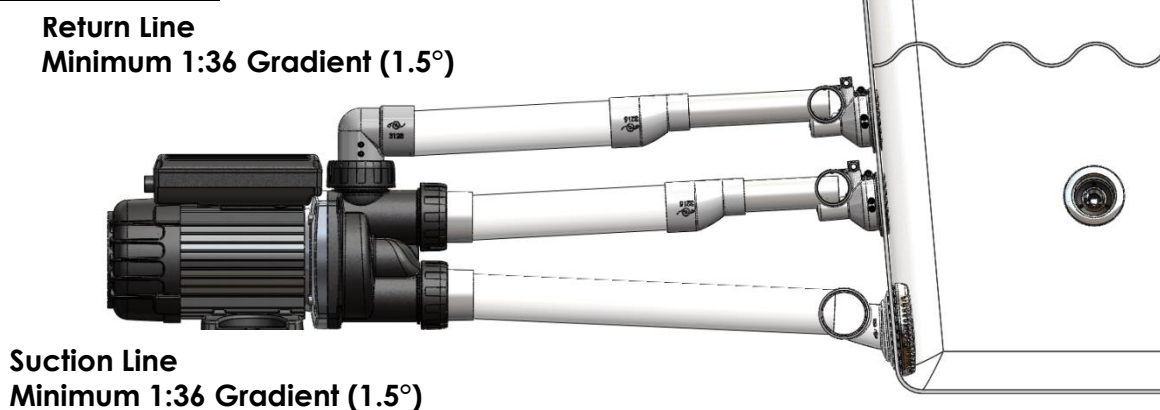
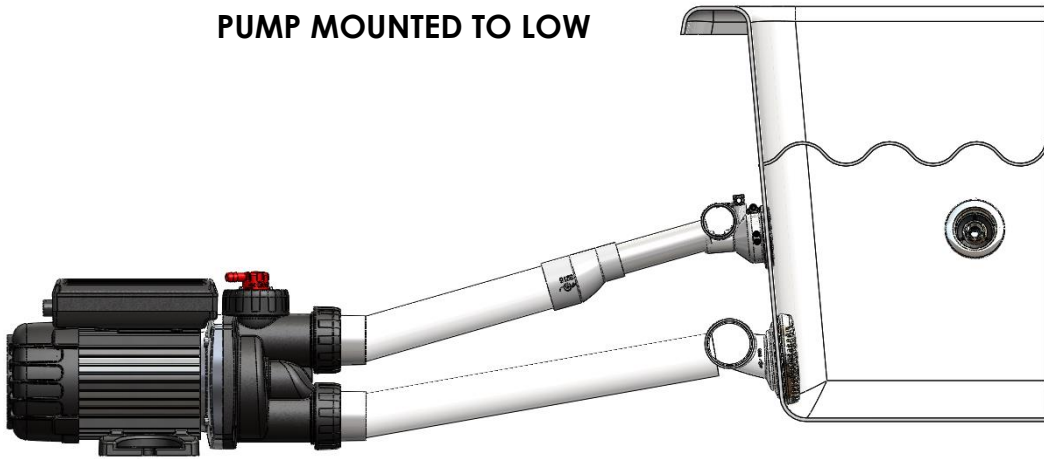
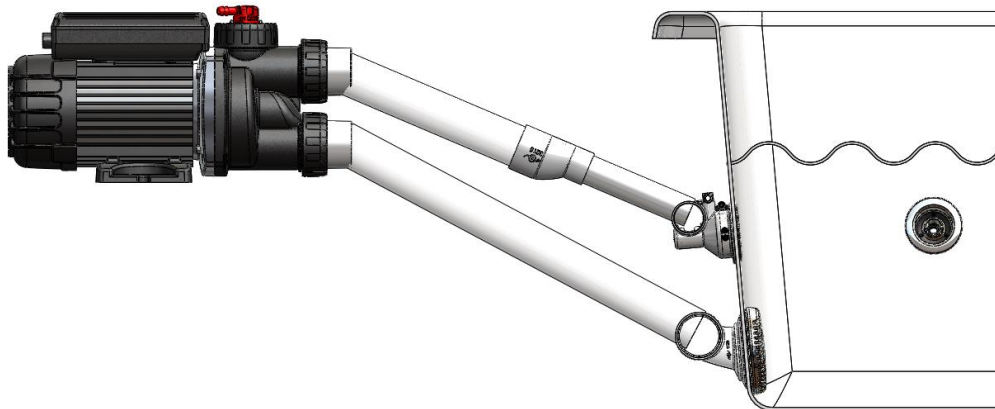

Diagram 2 Incorrect Spa Bath Pump Installations

PUMP MOUNTED TO LOW



PUMP MOUNTED TO HIGH



INCORRECT PIPEWORK
LOOP-PUMP WILL AIRLOCK

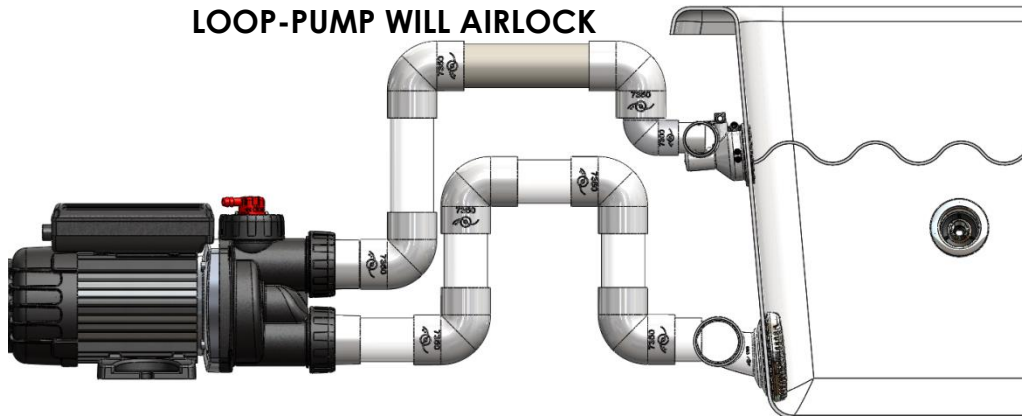

TriFlo Technical Data

Pump Model	Supply Voltage	Power (watts)	Heater (watts)	Current (amps)	Width (mm)	Height (mm)	Length (mm)	dB Rating	IP Rated
TF060-AH-50	230-240	600	0	3.7	148	198	384	65	55
TF075-AH-50-HF	230-240	750	0	4.4	148	198	384	65	55
TF110-AH-50	230-240	1100	0	5.4	148	198	406	65	55
TF060-XH, ET, ST, SK-50	230-240	600	700	6.8	148	198	384	65	55
TF075-XH, ET,ST, SK-50-HF	230-240	750	700	7.5	148	198	384	65	55
TF110-XH, ET,ST, SK-50	230-240	1100	700	8.6	148	198	406	65	55

Diagram 3 Air Tube Connections

Attach 3mm flexible air tube (supplied with the pump) onto the air switch nipple.

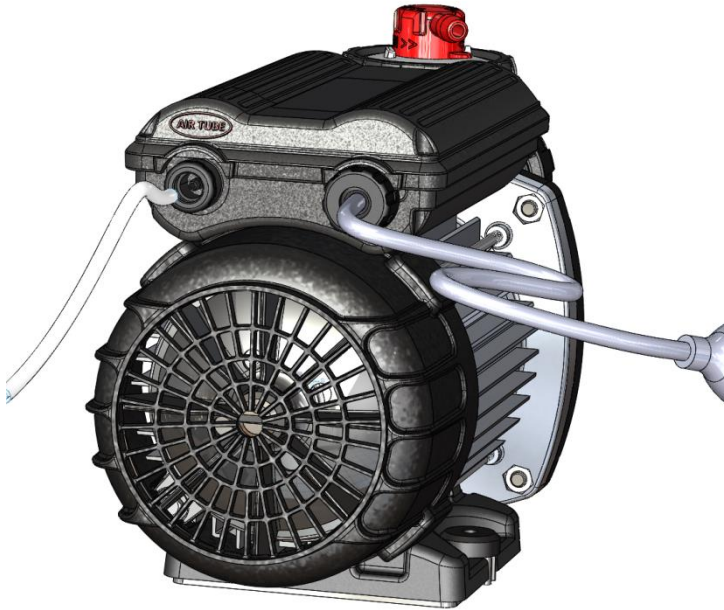
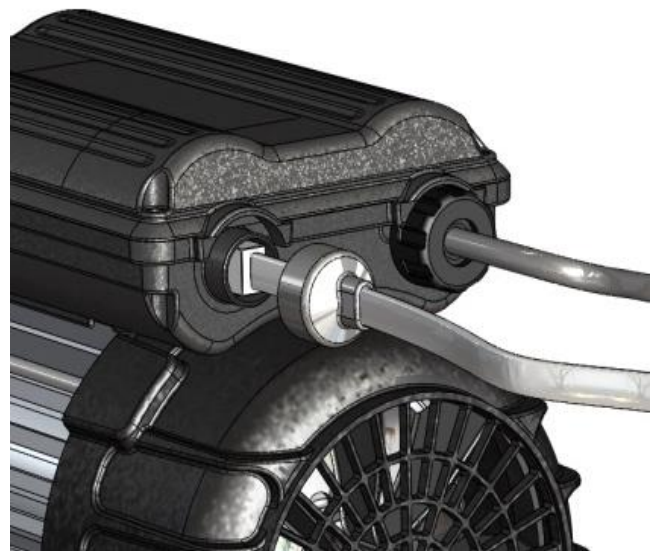
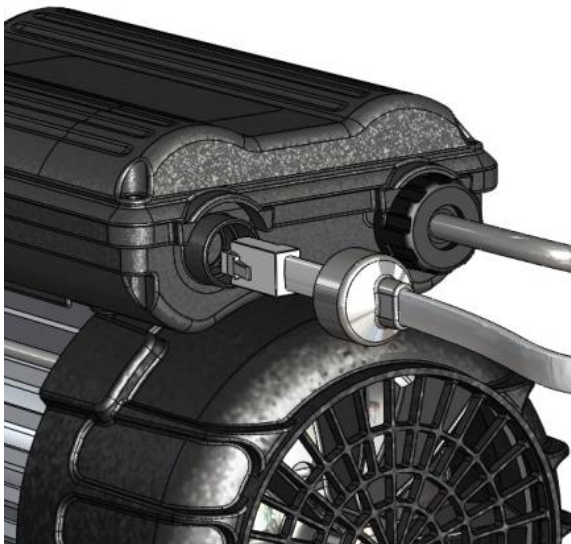

Diagram 4 Touch Pad Connections



1. Connect the touch pad cable into the housing, the alignment is shown above.
2. Push the connector into the housing until it “clicks” into the fixed position.
3. Push the protective rubber cap on the touch pad cable over the circular housing (*failure to do this will void the warranty*).



Diagram 5 Activating Air Bleed

***Important - Only Activate Air Bleed if pump does not prime (refer page 10)**

PRIOR TO AUGUST 2012

To activate air bleed,
Drill out blind hole inside
elbow (Use 4 mm drill bit)



Attach 10 mm Flexible
drain tube (Not Supplied)
Loop Tube Above Bath
Maximum Waterline

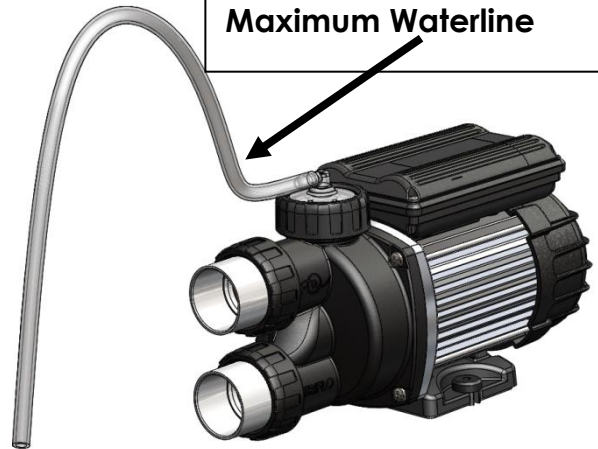

After August 2012

Twist Cap Air Bleed - Rotate
Fully Anticlockwise to Open

Attach 10 mm Flexible
drain tube (Not Supplied)
Loop Tube Above Bath
Maximum Waterline



TriFlo Spa Bath Pump

Congratulations on the purchase of your new TriFlo spa bath pump. The TriFlo spa bath pump has been specifically designed for spa bath applications to ensure that you have optimum spa jet performance and many years of trouble free operation.

The TriFlo pump internal design allows the water to self drain so that there is no residue water left in the pump when the spa is emptied in accordance with Local Health Regulations when installed correctly.

TriFlo spa bath pumps are designed for spa bath operation only and should not be used in chemically treated water or any other purpose without seeking written approval from Edgetec Systems Pty Ltd for the application.

TriFlo Models and Operation Guide

- **Auto-Heat:** The “Auto-Heat” TriFlo will help maintain your spa bath water temperature during your spa by heat transfer. This pump is activated by the air button installed on your bath.
- **Xtra-Heat:** The “Xtra-Heat” TriFlo has the integral flat plate 700watt Stainless Steel heater built into the pump, this will maintain your spa bath water temperature even in the largest spa baths. This pump is activated by the air button installed on your bath.
- **EEZI-Touch:** The “EEZI-Touch” TriFlo has the integral flat plate 700watt Stainless Steel heater built into the pump and a bath mounted touch pad which allows you to control the pump from the baths edge.
- Depressing the touch pad button will turn your pump “on or off”. When operating the Blue Led will light up.
- The heating function will automatically come on once the pump has primed and water is detected in the spa bath pump, if there is no water in the spa bath or insufficient water in the pump the pump will automatically shut down to protect your pump from running dry and causing potential damage to the mechanical seal.
- The Green indicator light on the touch pad is showing that the communication cable from the pump is fitted correctly and that there is power to the spa bath pump.
- **Sensa-Touch:** The “Sensa-Touch” TriFlo has the integral flat plate 700watt Stainless Steel heater built into the pump and a bath mounted touch pad which allows you to control the Pump & Heater function from the baths rim.
- Depressing the Pump button will turn your pump “On or Off”, if there is no water in the spa bath or insufficient water in the pump the pump will automatically shut down to protect your pump from running dry and causing potential damage to the mechanical seal.
- The heating function will automatically come on once the pump has primed and water is detected in the spa bath pump.
- The Red heater indicator lights will flash in sequence to indicate that the water is now being heated. When the water temperature has reached the setting chosen or the bath water is at the set temperature the red lights L, M or H will stay on depending on the setting chosen. To turn the heating down press the heater button, each time you press the heater button an indicator light will turn off and the set temperature will be reduced, when all the lights are off the heater is no longer active. To turn the heater back on, press the heater button and the heater will come back on at the highest setting.
- The Green indicator light in the centre of the touch pad is showing that the communication cable from the pump is fitted correctly and that there is power to the spa bath pump.



- **Spa-Key:** The “Spa-Key” has the integral flat plate 700watt Stainless Steel heater built into the pump. The Spa-Key is a unique radio operated remote control system which is housed in an immersible casing. The Spa-Key operates the pump, and heater – and has additional buttons to switch on a Spa Blower and Light – all in the one small casing. The Spa-Key is installed on the wall near the door in a moulded housing, from where it can operate any of the four functions of the highly sophisticated spa bath. The Spa-Key can be removed from the housing and carried around the bathroom to provide a hand held control function even while you are relaxing inside the bath. The Spa-Key will even function underwater – although we do not encourage submersion. The Spa-Key has a replaceable long life battery.
- Depressing the Pump button will turn your pump “On or Off”, if there is no water in the spa bath the pump will automatically shut down to protect your pump from running dry and causing potential damage to the mechanical seal.
- The heating function will automatically come on once the pump has primed and water is detected in the spa bath.
- To turn the heater “On or Off” depress the heater button on the remote control.
- To control the Spa Blower (where fitted) depress the Spa Blower button on the remote control.
- To turn the Light (where fitted) “On or Off” depress the Light button on the remote control.
- Your hand set that is provided with your pump has already been synchronized during assembly and is ready to use.
- **Extra or Replacement Hand Set.** Can be synchronized by turning the pump power off then on and pressing the PUMP key on the SPA-KEY handset within 15 seconds, then the pump will give a little surge to tell you that the synch mode is finished. Refer www.edgetec.net for further technical information.

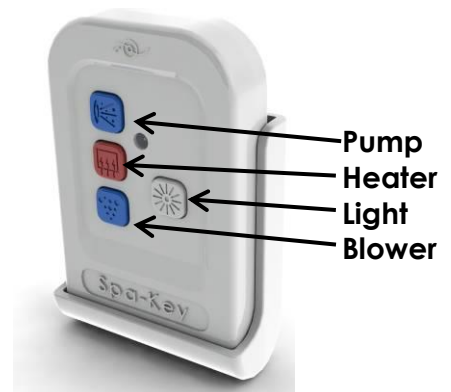

Pro-Tec Pump Cover – External Applications

The Pro-Tec pump cover is complete with wall brackets and mounting base and can be adapted for left hand or right hand mount-standard and TriFlo applications, available at www.edgetec.net or sales@edgetec.net.

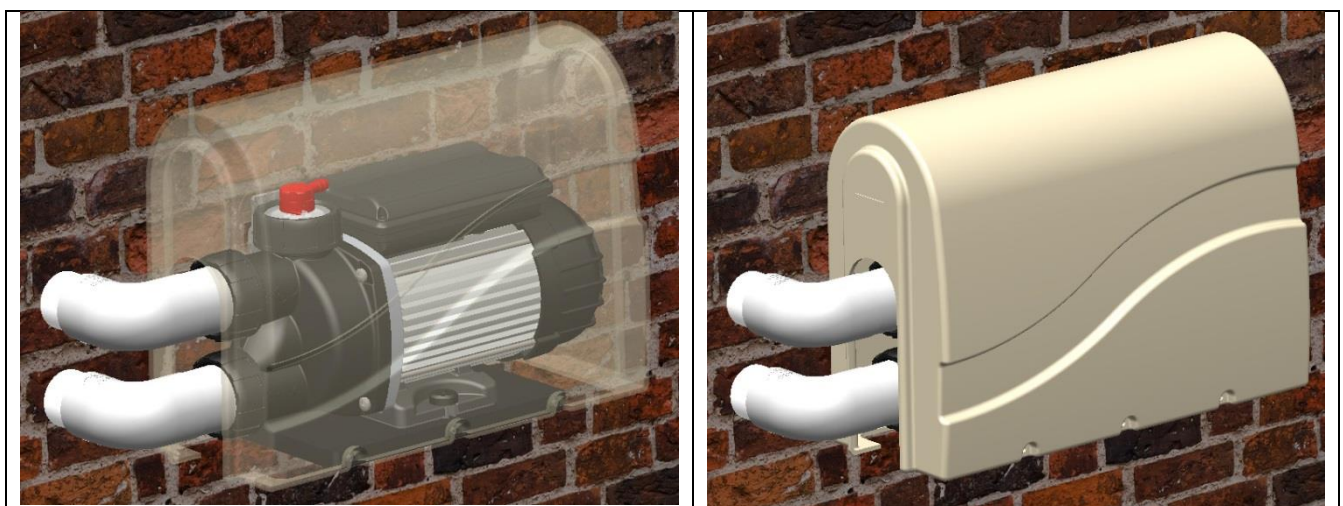

This appliance is not intended for use by young children or infirm persons without supervision

Installation Instructions (refer diagram 1)

1. To ensure optimum performance of your spa bath the TriFlo pump should be located as close as possible to your spa bath (maximum 3 Metres). To ensure high efficiency of your TriFlo pump, use the minimum amount of pipe fittings during your pump to spa bath installation. Correct installation allows water to drain from pipe work to pump and from pump to the self-drain suction fitting in the bath.
2. The pump can be located internally or externally. If you are fitting the pump externally, fit the Pro-Tec pump cover as shown on page 7 (not supplied).
3. Internal installation must have adequate ventilation (minimum area 50cm²) for the pump motor. Inadequate ventilation may cause the motor to cut out on thermal over load. If this occurs the thermal will reset when the motor cools down.
4. A suitable drain tray on internal installations should be installed to avoid water damage to property should any leaks occur from pipe work, connections or normal wear.
5. Install the TriFlo pump as per diagram 1 (using the least amount of elbows, if required). It is most important that the suction line be installed with a minimum of 1:36 gradient (1.5°) (refer Diagram 1) as this allows the water to drain from the pump and pipe work when the bath is emptied.
6. The pump should never be installed as shown in diagram 2.
The pump return line should be installed below the water level of the bath, if the return line is above the water level the pump may air lock and may not prime (pump starts but no jets are operating). Should this occur you may have to activate the air bleed valve (Refer to Activating Air Bleed; diagram 5) or your pump may be mounted too high check pump height.
7. The pump to be fixed to the frame or support through the pump mounting points in the pump base with appropriate fasteners. Two anti-vibration isolation washer buttons are provided with the pump for the fasteners.
8. Barrel unions only require to be hand tightened, over tightening may cause damage to the unions and or o rings. *Do not use stillsons or any other mechanical leverage.*
9. Before connecting the pump to the pipe work, ensure that all the pipe work is clear of any debris as small particles can cause blockage to spa jets or the pump impeller causing serious damage.
10. IMPORTANT REQUIREMENT FOR PUMP SERVICE:
 - Pump installation must provide reasonable access for pump removal.
 - To allow for pump removal a serviceman must be able to reach the barrel unions.
 - For under the hob installation- an access panel must be provided on every installation.

Electrical Connection

1. Spa bath pumps must be fitted in accord with AS3000 electrical wiring rules
2. AS3000 requires all 240 V pumps installed in Spa Bath to be supplied from a circuit protected by a residual current device (RCD) with a maximum rated residual current 30 mA.
3. The TriFlo spa bath pump is fitted with a standard lead and three pin plug for 240-220V 50Hz power supply.
4. The spa bath pump power connection must be accessible so that it can be independently switched off in case of an emergency but must not be accessible by the bath user.
5. If damage occurs to the power cord it must be replaced by Edgetec or an authorised service agent or suitably qualified person.

Air Tube Connection “Auto-Heat & Xtra- Heat Models” (refer diagram 3)

1. Supplied with your spa pump is a 4 metre roll of 3mm clear air tube, fit one end of the air tube to the air button (supplied with the spa bath) on the spa bath.
2. Uncoil the air tube so that you can connect it to the air switch located on the pump (refer diagram 3) at the rear of the pump motor on the capacitor cover.
3. *Cut off excess tube and ensure that the tube is not kinked, do not wrap or loop excess tube around frame work of the bath or pipe work as this may cause the air button not to operate correctly.*

Touch Pad Cable Connection “Sensa/Eezi-Touch - Models” (refer diagram 4)

1. Supplied on your spa bath is the Sensa Touch Pad, connected to the touch pad will be a 4 metre data cable.
2. Uncoil the data cable and you will see that one end is already connected to the touch pad on the spa bath.
3. Connect the other end to the pump as per diagram 4, ensuring that the data cable connection clip is being inserted correctly. Push the clip in until you hear it “click” into the fixed position.
4. Push the protective rubber cap that is on the cable over the circular housing (refer diagram 4) to protect the touch pad cable connection. **Failure to do this will void your warranty.**
5. When power is activated there will be a “Green” indicator light activated on the touch pad to show that the connection is fitted correctly from the pump to the touch pad.

Start Up

1. Fill the spa bath to approximately 50mm above the spa jets, check the pump and pipe connection for any leaks.
2. Ensure that the pump power outlet is switched to the “on” position.
3. Auto-Heat & Xtra-Heat pumps. Press the air button on the spa bath, the pump will start and purge the air from the system and your spa will start to operate. To stop the spa, simply press the air button again.
4. Sensa/Eezi-Touch pump. Press the pump symbol on the touch pad, the pump will start and purge the air from the system and your spa will start to operate. To stop the spa, simply press the pump symbol on the touch pad again.
5. Spa-Key. Press the pump symbol on the hand set, the pump will start and purge the air from the system and your spa will start to operate. To stop the spa, simply press the pump symbol on the hand set again.
6. If the pump fails to prime you may have an air lock, please refer to activating air bleed. **If after activating the air bleed and the pump will still not prime – check the height of the pump and adjust to the correct level.**



Your spa bath pump should be installed on a well drained location or on a suitable drain tray on internal installations to avoid water damage to property should any leaks occur from pipe work, connections or normal wear.



Never run your spa pump without water as this can cause serious damage to the mechanical seal which may cause the spa pump to leak. Running the pump without water will void your warranty.

Activating Air Bleed- (refer diagram 5)

Prior to August 2012 the air bleed fitted was a sealed unit which required a drill operation to activate the air bleed.

From August 2012 the Air Bleed has a Twist Cap which will open the Air Bleed when the Cap is rotated Fully Anticlockwise. (No Drilling Required)

Pre August 2012

1. The air bleed valve is manufactured in the closed position and if your pump is installed as per diagram 1 you will not need to activate this valve.
2. If your spa pump is not priming, you will have to activate the air bleed valve. To do this you will require a 4mm or 3/16 drill bit. Carefully drill out the blank in the air bleed elbow ensuring that you do not drill through the outer wall (refer diagram 5), the air bleed valve is now activated.
3. It is common for air bleed valves to “Squirt” water when sealing, this will occur every time the pump is switched on. Once the internal valve is seated, the water “squirt” will stop.
4. To avoid water damage, ATTACH 10 MM FLEXIBLE DRAIN TUBE (NOT SUPPLIED) LOOP TUBE ABOVE BATH MAXIMUM WATERLINE AND TERMINATE PIPE IN DRAIN TRAY-SEE BELOW

From August 2012

From August 2012 the Air Bleed has a Twist Cap which will open the Air Bleed when the Cap is rotated Fully Anticlockwise.

Rotating the Twist Cap Fully Clockwise will close the air Bleed.

The pump is shipped with the air bleed in the closed position.

1. The air bleed valve is supplied in the closed position and if your pump is installed as per diagram 1 you will not need to activate this valve.
2. If your spa pump is not priming, you will have to activate the air bleed valve. To do this Rotate the Red Cap air Bleed valve Fully Anticlockwise - the air bleed valve is now activated.
3. It is common for air bleed valves to “Squirt” water when sealing, this will occur every time the pump is switched on. Once the internal valve is seated, the water “squirt” will stop.
4. To avoid any water damage, ATTACH 10 MM FLEXIBLE DRAIN TUBE (NOT SUPPLIED) LOOP TUBE ABOVE BATH MAXIMUM WATERLINE AND TERMINATE PIPE IN DRAIN TRAY



After August 2012



Prior August 2012

Trouble Shooting Guide

Auto-Heat & Xtra-Heat - Spa Pump will not start	
Possible Cause	Suggested Action
Air tube is not connected	Check the air tube is connected to the air button on the spa bath and the air switch on the pump
Air Tube is kinked	Check the air tube is not kinked or wrapped around the frame work as this will stop the pulse of air required to activate the pump
Air button is not operating	Check the air button is clear of debris (i.e. tile grout) and that the air button plunger moves freely.
Mains Power to pump is not switched on	Check the power point is in the "on" position Check the Power Point has 240V Power
Faulty Pump Air switch	Contact service technician or spa installer.
Pump is not Priming - No water coming from jets	
No water from Spa Jets	Activate Air Bleed-Refer to activating Air Bleed- page10 Check the height of pump Check that adjustable spa jets are in the open position
Eezi & Sensa-Touch - Spa Pump will not start	
Possible Cause	Suggested Action
Mains Power to pump is not switched on	Check the Power Point has 240V Power Check that the power point is "on". Green indicator light should be glowing on the touch pad to indicate power.
Communication Cable is not connected	Check the communication cable is connected to the Touch Pad and the communication port on the pump. Green indicator light should glow on the touch pad to indicate power
Touch Pads Lights are all flashing	The touch pad may have gone into fault mode, switch the power off at the power point, wait 15 seconds and the switch the power back on. Only the Green light on the touch pad should now be illuminated.
Mains Power to pump is not switched on	Check the power point is in the "on" position Check the Power Point has 240V Power
Pump is not Priming - No water coming from jets	
Pump runs but stops after 10 seconds	Activate Air Bleed-Refer to activating Air Bleed- page10 Check the height of pump Check that adjustable spa jets are in the open position
No water coming from Spa Jets	Contact service technician or spa installer.
Spa-Key - Spa Pump will not start - www.spakey.com.au	
Possible Cause	Suggested Action
Mains Power to Spa pump not switched on	Check the Power Point has 240V Power
No Red LED glow on handset.	Check the batteries are installed in your handset. Press any button on the handset, if the Red LED glows-battery is OK. Dim or No Red glow replace battery.
Mains Power to Spa pump not switched on	Check the power point is in the "on" position Check the Power Point has 240V Power
Pump is not Priming - No water coming from jets	
Pump runs but stops after 10 seconds	Activate Air Bleed-Refer to activating Air Bleed- page10 Check the height of pump Check that adjustable spa jets are in the open position
No water from Spa Jets	Contact service technician or spa installer.



This appliance is not intended for use by persons (including children) with reduced physical, sensory or mental capabilities, or lack of experience and knowledge, unless they have been given supervision or instruction concerning use of the appliance by a person responsible for their safety.

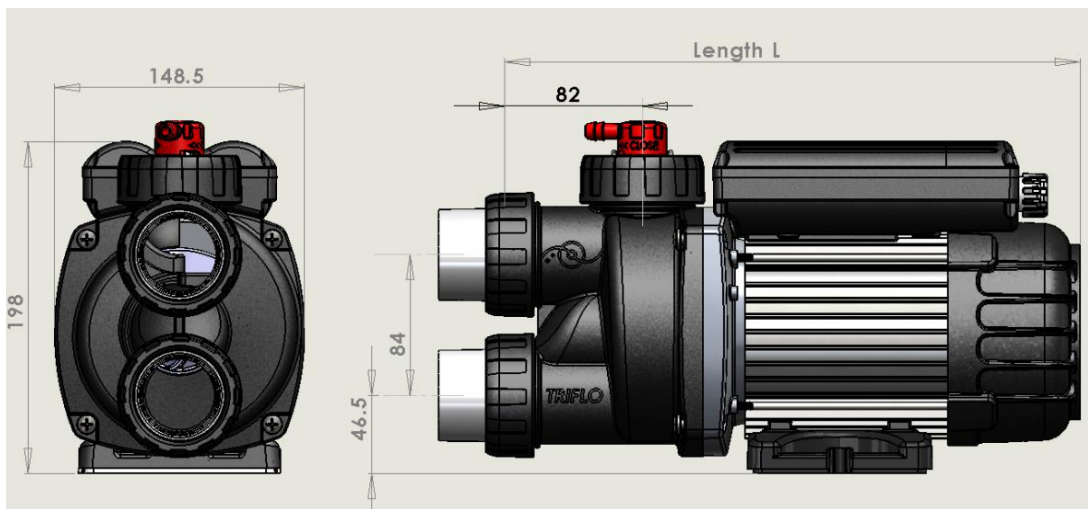

Edgetec Product Warranty

Edgetec Systems Pty Ltd warrants that the items sold hereunder shall be free from defects in material and workmanship for a period of one (1) year at the time of the original purchase date and to the original purchaser.

Terms & Conditions

1. This product is to be installed in accordance with the installation and operating instructions provided failure to do so will void your warranty.
2. The product warranty does not cover:
 - fair wear and tear, negligence, misuse or abuse,
 - incorrect installation or running the pump dry,
 - water damage from external sources or inadequate ventilation,
 - cement or other building debris blocking the pipe work or impeller,
 - chemically treated water,
 - high voltage spikes or acts of nature,
 - repairs by unauthorised persons,
 - Incorrect voltage.

Edgetec Systems Pty Ltd has service agents throughout Australia, should you require warranty service please contact our service department for your nearest service agent.

Edgetec Systems Pty Ltd goods come with guarantees that cannot be excluded under the Australian Consumer Law. You are entitled to a replacement or refund for a major failure and compensation for any other reasonably foreseeable loss or damage. You are entitled to have the goods repaired or replaced if goods fail to be of acceptable quality and the failure does not amount to a major failure. No unauthorized personnel can make any warranty representation on the behalf of Edgetec Systems Pty Ltd without written permission.

Commercial Installation

Commercial Warranty: Has a limited warranty of (6) months from the date of purchase to these commercial installations including (but not limited to) hotels, motels, caravan parks and health clubs installations etc.

13 Lieber Grove
 Carrum Downs
 Victoria 3201 Australia
 Tel: (613) 9775 0882
 Fax: (613) 9775 0881
 Email: sales@edgetec.net
 Web: www.edgetec.net



Proudly Australian Owned