



OWNERS MANUAL

Thank you for purchasing a Fezzari Bicycle

Fezzari bicycles are made with the finest materials and craftsmanship. Fezzari was founded on the premise that discerning customers will embrace products of superior performance, quality, and value. We hope you appreciate your Fezzari experience. We want this to be the most rewarding purchase you have ever made. If you have any feedback, comments, or questions, we look forward to hearing from you.



General Warning

In order to use and enjoy your Fezzari bicycle safely and to get the best durability and performance from your Fezzari, please read this manual carefully and thoroughly before riding. The information contained in this manual is to be used as a guideline for safe operation and is not intended to replace any safety rules or laws that may be in force in your area. Even if you have ridden a bicycle for years, it is important for every person to read this manual before you ride your new bicycle.

How to use this manual

This manual is organized into three sections.

Section 1 - Unpacking/Assembly

This section will cover the process of unpacking your Fezzari bicycle and the initial assembly to get it ready to ride. Most Fezzari bicycles have gone through our 23-Point Custom Setup and have been tuned and packaged by our expert technicians.

Section 2 - Operation/Riding

This section covers safe operation. While most people know how to ride a bicycle, we want you to be able to enjoy your Fezzari for many years to come by operating it properly. This covers topics such as: pre-ride checklist; best-use practices for shifting and braking; prolonging bike life, etc.

Section 3 - Maintenance

This manual cannot provide you with every possible fix for any problem that your bike may have, but we want to give you enough basic knowledge to cover simple fixes and adjustments. Bicycles require special tools to service. If you do not feel comfortable working on your bike, please get a qualified technician.

For the most up to date information, please visit us at www.fezzari.com/support/manuals.

Many of the components on your Fezzari bicycle have separate manuals that provide additional information. You can find most component manuals on the manufacturers' websites.

Table of Contents

| | | | |
|--|-----------|--|----|
| Thank you for purchasing a Fezzari Bicycle | 2 | Lubrication | 20 |
| General Warning | 2 | Inspection | 20 |
| How to use this manual | 3 | Pedals | 21 |
| Table of Contents | 4 | Wheels | 21 |
| Important Symbols and Terms | 5 | Tires & Tubes | 21 |
| Section 1 - Unpacking/Assembly | 7 | Spokes and Wheels | 21 |
| Unpacking | 7 | Brakes | 21 |
| Box Contents | 7 | Common Rim Brake Adjustments | 21 |
| Initial Inspection | 7 | Common Disk Brake Adjustments | 22 |
| Packaging Materials | 9 | Brake Pads | 23 |
| Registration | 9 | Gears | 23 |
| Assembly | 9 | Derailleur Hanger Alignment | 24 |
| Assembly Overview | 9 | Cable Tension | 24 |
| Step 1 - Attach Handlebar | 10 | Limit adjustment | 25 |
| Step 2 - Attach Rear Derailleur | 11 | Suspension Fork Adjustment & Maintenance | 26 |
| Step 3 - Install Rear Wheel | 11 | General Suspension Adjustments | 26 |
| Step 4 - Install Front Wheel | 13 | Suspension Service Intervals | 27 |
| Step 5 - Attach Seat | 13 | Storage | 27 |
| Step 6 - Attach Pedals | 15 | Baby your Fezzari | 27 |
| Step 7 - Inflate Tires | 16 | FEZZARI LIMITED WARRANTY | 27 |
| Section 2 - Operation | 17 | SUPPORT | 28 |
| Operation | 17 | | |
| Before Riding | 17 | | |
| While Riding | 18 | | |
| Section 3 - Maintenance | 20 | | |
| Maintenance | 20 | | |
| Cleaning | 20 | | |

Important Symbols and Terms

Bicycling can be a hazardous activity even under the best of circumstances. By riding, you are assuming the risks associated with the activity, which can include serious injury or death. Properly maintaining your Fezzari is your responsibility and will help reduce the risk of injury. This manual contains many symbols, terms, and formatting to call attention to warnings and cautions.



The **Warning** sign indicates a potentially hazardous situation that, if not avoided, could result in serious injury or death.



The **Caution** sign indicates a potentially hazardous situation that, if not avoided, could result in minor to moderate injury, or damage to the bicycle frame or components.



The **Note** sign indicates text that provides helpful or other important information.



Bold lettering indicates important text and points to note.

Throughout this manual, we refer to different types of bikes—road bikes and mountain bikes. Road bikes generally have drop handlebars, narrow tires, and are designed for road riding. Mountain bikes have straight handlebars, wide tires, and are designed for road and off-road riding. If no distinction is made between the two bikes, then the comments and procedures outlined in the manual are the same for both bikes.

Road Bikes

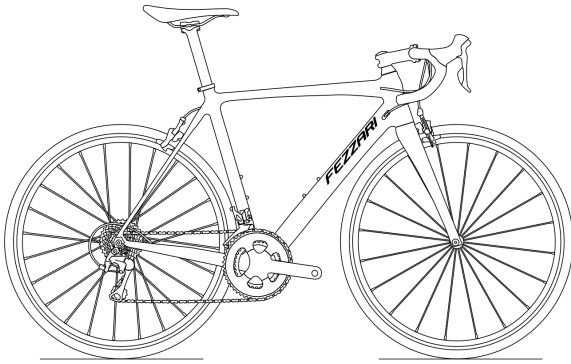
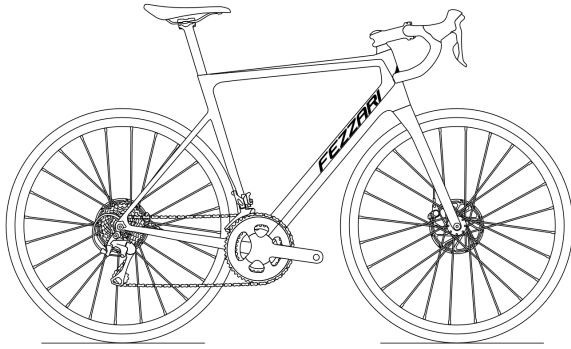

Mountain Bikes

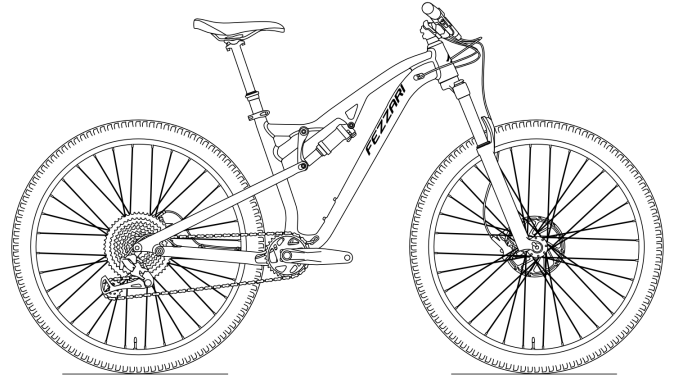

Section 1 - Unpacking/Assembly

Unpacking

Box Contents

Following is a list of all packaging contents shipped with your Fezzari:

- Fezzari Bicycle Frame
- Seat and Seatpost
- Handlebars
- Front Wheel
- Rear Wheel
- Box containing:
 - Tools needed to assemble your Fezzari
 - 4 mm, 5 mm, and 6mm, Allen Wrenches (for installing and adjusting handlebars, brakes, wheels and seatpost)
 - Component Manuals
 - Additional reflectors
- Additional Purchased Accessories

Initial Inspection

All major parts are identified on the following pages.

Please familiarize yourself with these parts prior to assembling or riding your Fezzari. Please check your bicycle frame, parts, and components thoroughly for any damage that may have been sustained during shipping. Do not discard the packaging. Be careful to avoid scratching the frame when untying or unpacking the bicycle and components.

If you find something missing or damaged, please contact the Fezzari Customer Support Team
<https://www.fezzari.com/contact>.

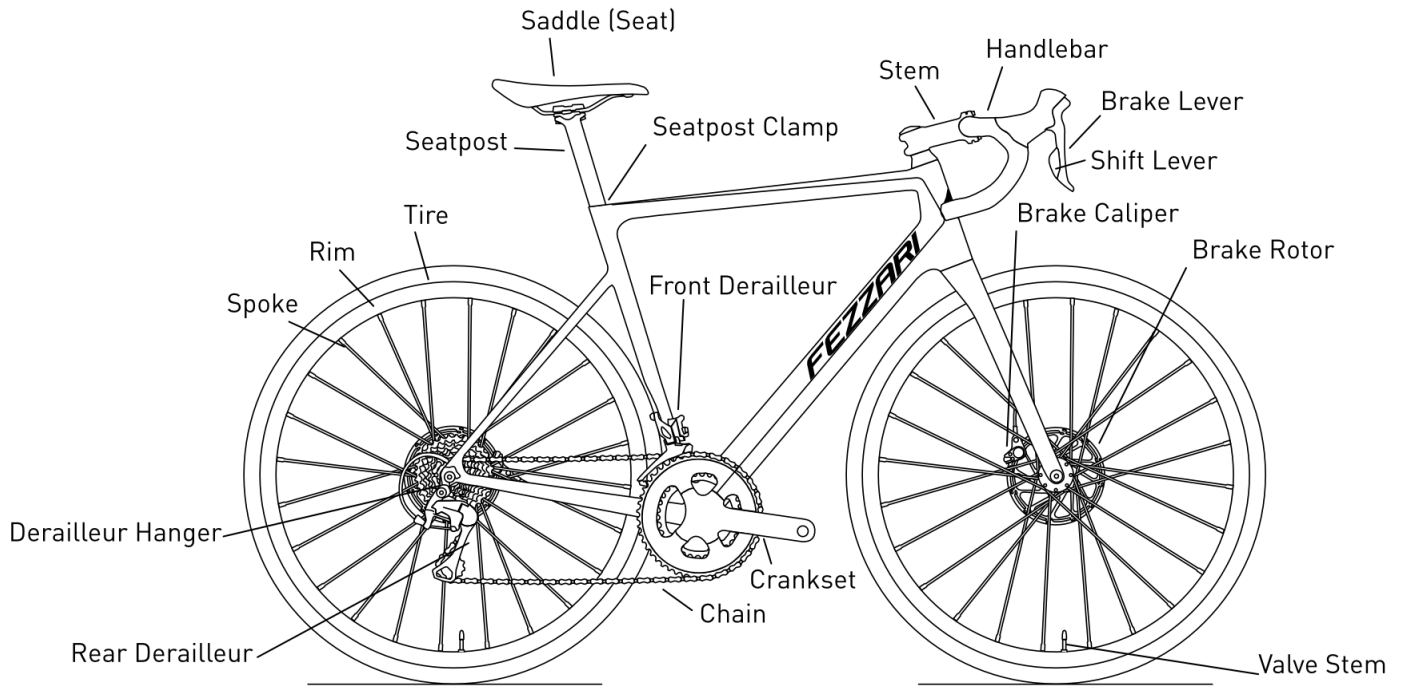

Figure 1: Names and Locations of Components and Frame Parts on a Road Bike

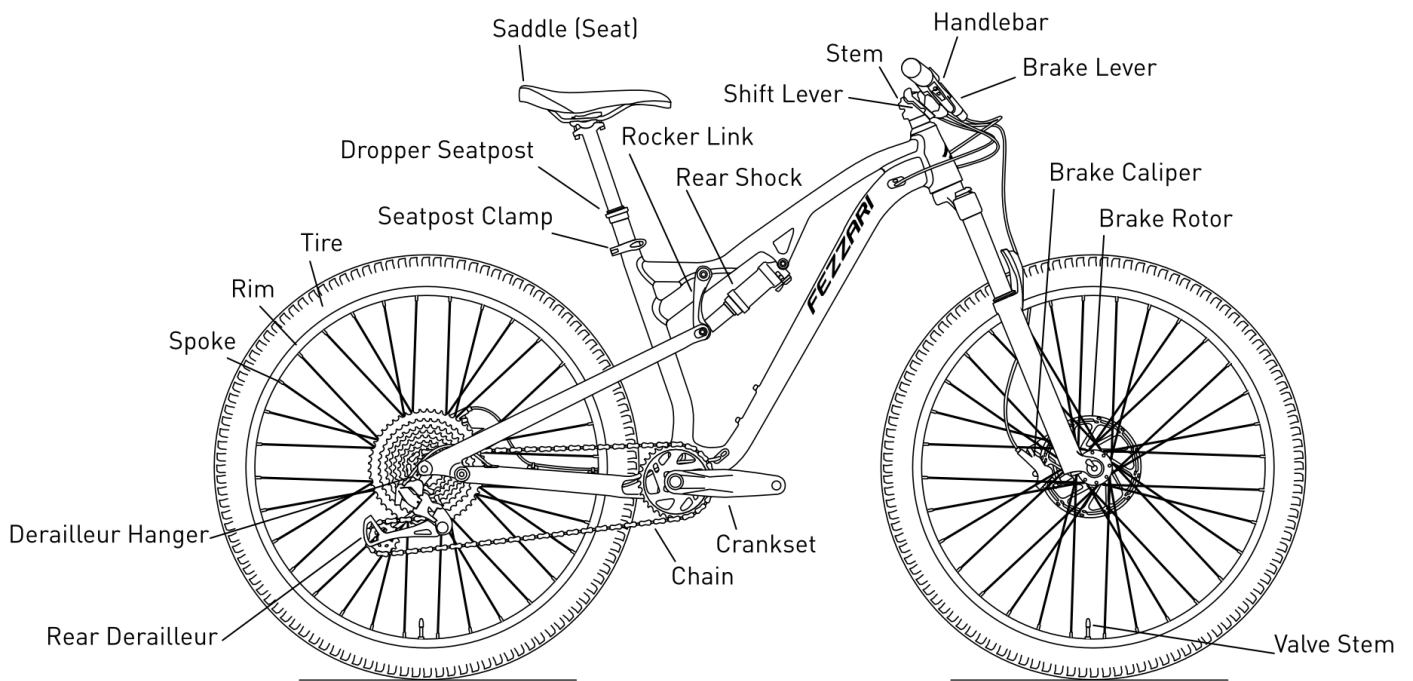

Figure 2: Names and Locations of Components and Frame Parts on a Mountain Bike

Packaging Materials

When removing packaging materials, be careful of the following:

- Zip ties - when removing zip ties, be careful not to damage the finish or paint on your bike. Use scissors or side-cuts, never use a knife.
- Packaging - when removing any packaging, make sure that any components are not discarded with the packaging materials.
- Plastic protectors - there are plastic protectors placed in the wheels that can sometimes pull out important end caps from the wheel axles. **Make sure that your wheels have the end caps in place before installation and before disposing of any packaging materials.**
- Fezzari has a 30-day Love it or Return it policy. One requirement of that policy is that the bike be returned in the original box and packaging. Please keep all the original packaging materials for the first 30 days of ownership.

Registration

Registering your bike will help keep you updated with any new information relevant to your bicycle. It will also help assist law enforcement in the event that your bike is stolen.

The serial number of your bicycle frame is attached to the underside of the down tube or underneath the bottom bracket shell (**Figure 3**). Please register your bike with your local law enforcement.

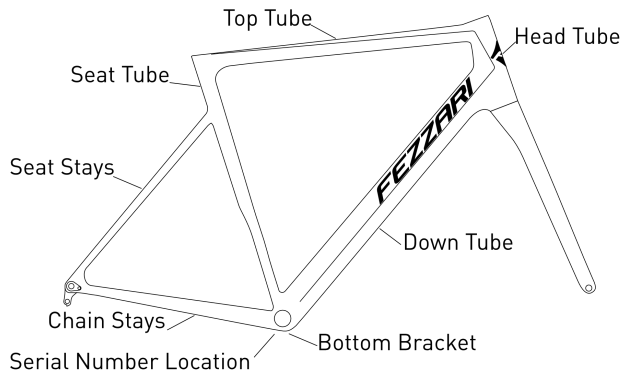

Figure 3: Names of Bicycle Frame Parts

Assembly

Assembly Overview

Your Fezzari comes with the tools needed for assembly. Assembly is generally a 7 step process. Packaging is optimized for each bike so there may be differences in assembly. Only follow the steps that are pertinent for your bike.

Following is an overview of the steps for assembly and then the details of each step.

Step 1 - Attach Handlebar

Step 2 - Attach Rear Derailleur

Step 3 - Install Rear Wheel

Step 4 - Install Front Wheel

Step 5 - Attach Seat

Step 6 - Attach Pedals

Step 7 - Inflate Tires

Step 8 - Ride Your Bike!

► NOTE: All references to “left” and “right” in this manual are related to riding position on the bicycle.

▲ CAUTION Do not squeeze the brakes when the wheels are not installed in the frame. This can cause the brake calipers to close on themselves, requiring special tools to fix.

If you have any problems or questions with assembly contact us at <https://www.fezzari.com/contact>.

Step 1 - Attach Handlebar

The bicycle controls are already mounted to the handlebars. All you will need to do is mount and align your handlebar to the front of the stem.

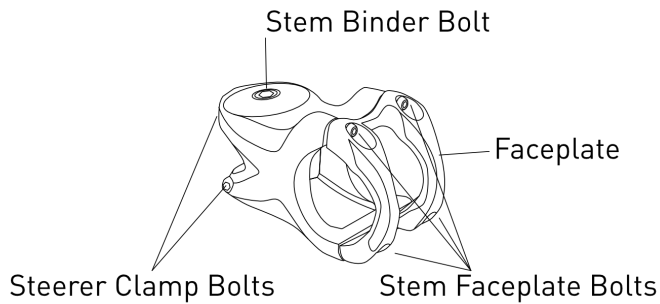

Figure 4: Names of Stem Bolts

During the build process, the stem should have been aligned with the fork. If it is not, the process to straighten the stem is easy. Using the included Allen wrenches, loosen the steerer clamp bolts and align the stem with the front wheel (**Figure 4**). Once the stem is straight, make sure that the stem binder bolt is snug. Do not tighten the stem binder bolt so tight that it causes the steering to bind or stick. Next, tighten the steerer clamp bolts alternating each one until they are tightened to the stem manufacturers specifications.

Remove stem faceplate bolts and faceplate from the stem. Put the handlebar and stem faceplate in place and finger-tighten (at this point) the stem faceplate bolts. Make sure the cables aren't twisted.

Center the handlebar in the stem, and over the front wheel. Tighten the stem faceplate bolts with the correct size Allen wrench evenly until they are all at the stem manufacturers recommended torque. (**Figure 5.1,5.2**)

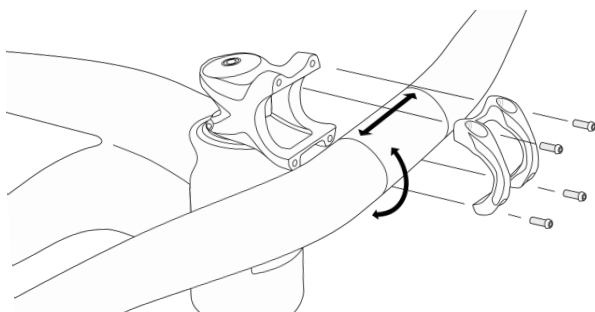

Figure 5.1 Mountain Handlebar Installation

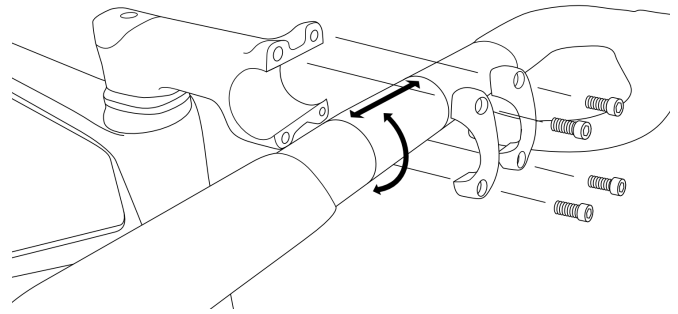

Figure 5.2: Road Handlebar Installation

Ensure that the fork and stem will turn easily and smoothly from side to side without your handlebar slipping.

Make sure that there is no noticeable play front to back between the fork and frame by holding the front brake closed, with the fork turned 90 degrees to the left, and rocking the bicycle back and forth. There should be no movement between the frame and fork.

▶ NOTE: If you do not fully understand any of the above steps or if you think the handlebar is not tightened properly, please contact the Fezzari Customer Support Team.

⚠ CAUTION Loose or damaged handlebar grips or extensions can cause you to lose control and fall.

⚠ CAUTION Make sure all wires and cables are free from obstruction and not wrapped around the stem or fork.

⚠ WARNING An insufficiently tightened stem binder bolt, handlebar binder bolt, or steerer clamp bolt may compromise steering, which could cause you to lose control and fall. Place the front wheel of the bicycle between your legs and attempt to twist the handlebar/stem assembly. If you can twist the stem in relation to the front wheel or turn the handlebars in relation to the stem, the bolts are not sufficiently tightened.

Step 2 - Attach Rear Derailleur

For safety in transit, the rear derailleur may have been unbolted from the derailleur hanger. However, for ease of installation, the cable tension, limit screws, and chain have all been tested and adjusted for proper function.

The derailleur attaches to the derailleur hanger in a specific orientation that is guided by a tab on the derailleur hanger. Rotate the derailleur so that the tab on the derailleur is above the tab on the hanger (**Figure 6**). Attach the derailleur to the hanger by screwing it clockwise with a 5mm Allen wrench, tightening to the manufacturer's recommended torque specification (typically 8-12 Nm).

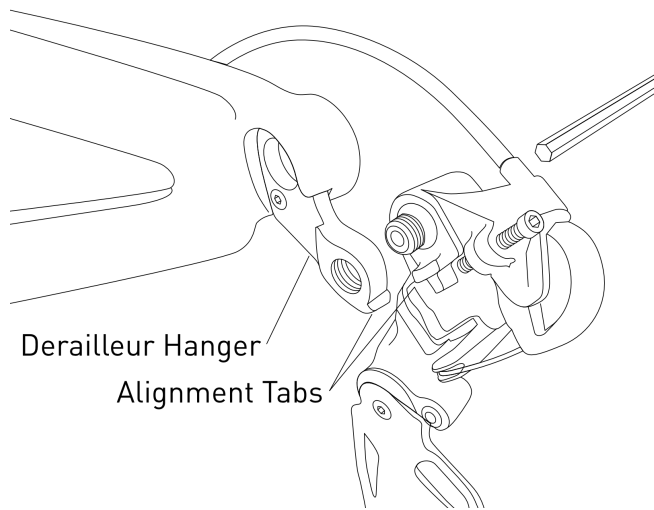
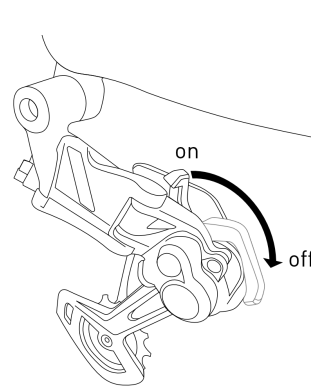

Figure 6: Derailleur Installation

Step 3 - Install Rear Wheel

Rear derailleurs that were designed to be used with a single chainring will be equipped with a clutch mechanism. This clutch exists to make rear wheel installation easier. The clutch should be turned to the open, or unlocked position for wheel installation. On most derailleurs this is done by flipping the clutch lever to the unlocked position. On SRAM derailleurs, this is done by rotating the pulley cage counter-clockwise until the lock button can be depressed and the cage allowed to rest against the lock (**Figure 7**).

Lever type clutch



SRAM clutch

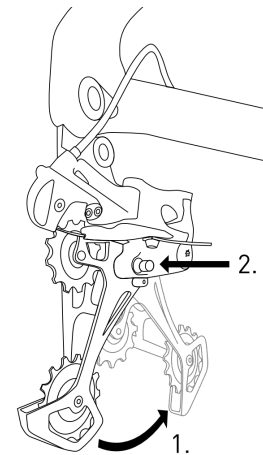

Figure 7: Clutch Operation

Once the clutch is disengaged on the derailleur (if applicable), position the rear wheel so that the chain is resting on the smallest cog of the cassette. Carefully slide the wheel up into the frame dropouts, making sure that the disc brake rotor is positioned in between the brake pads. (**Figure 8**)

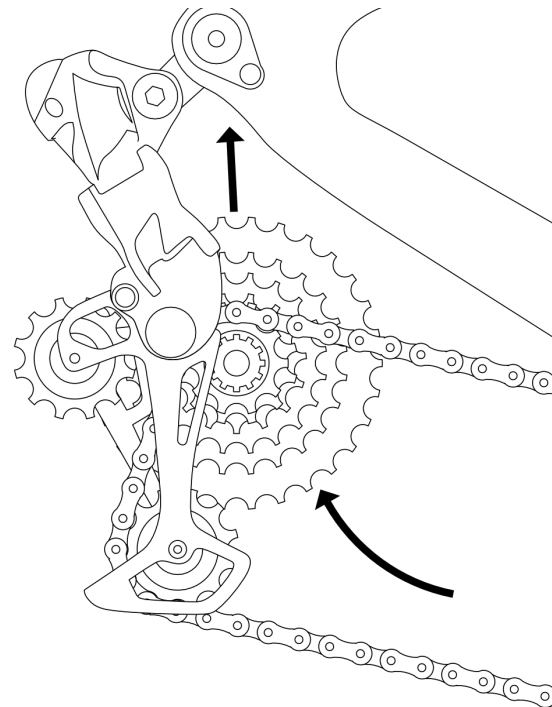

Figure 8: Rear Wheel Installation

There are two main types of attachment systems for wheels: **quick release** and **thru axle**. While there are various types of thru axle systems, we will cover the most common types. If you do not see your axle in this manual, feel free to contact us.

Thru-axle installation:

On bicycles with disc brakes, there is often a plastic spacer installed in the brake caliper during shipping to ensure the brake pads do not clamp down on themselves. **(Figure 11)** Remove the spacer making sure not to squeeze the brake lever. With the wheel in position, slide the thru-axle from the left side of the bike through the frame dropouts and rear wheel and thread it into the right side of the frame. **(Figure 9)** Use the supplied tools to tighten the thru-axle. After installing the wheel, engage the clutch on the rear derailleur (if applicable).

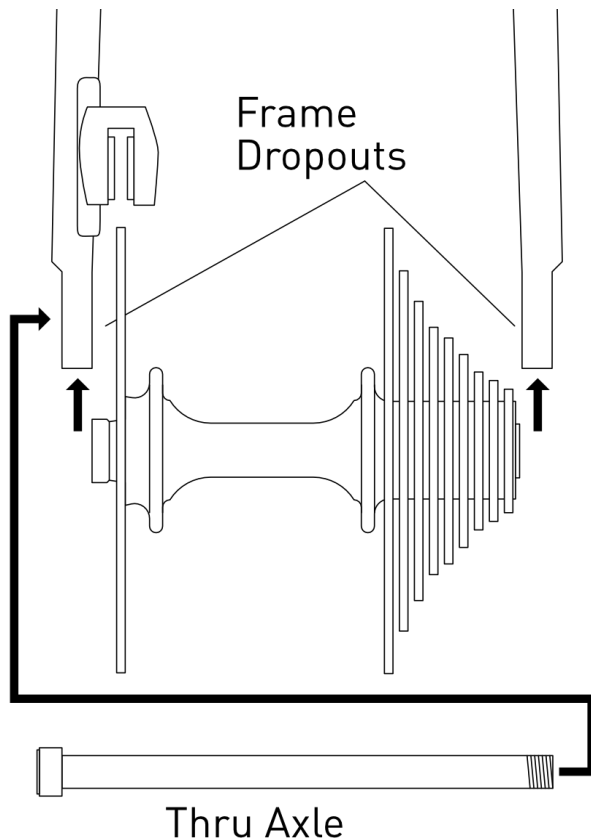

Figure 9: Rear Thru-Axle Installation

CAUTION Insert the tool fully into the thru-axle before tightening or loosening the axle.

The tool must be inserted deeper than 10 mm before use.

Quick Release Installation:

If the bike is equipped with a quick-release skewer, unscrew the Cap on the end of the Rod and remove one spring. Slide the Rod through the center of the wheel. Slide the second spring onto Rod (the fat end of springs should be away from the wheel on both sides). Screw on the Cap 1-2 turns (keep it loose at this point). Slide the wheel into the position. Insert the wheel between the chainstays so that it firmly touches the inside of both frame dropouts. The quick release lever should be on the left side of the bike.

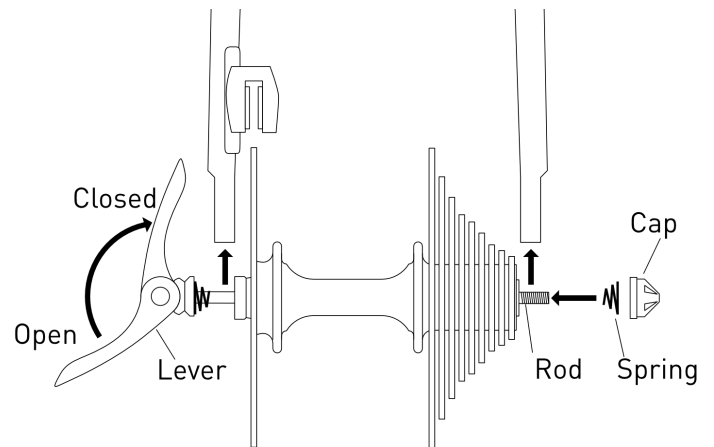

Figure 10: Rear Quick-Release Installation

On bicycles with disc brakes, there is often a plastic spacer installed in the brake caliper during shipping to ensure the brake pads do not clamp down on themselves. **(Figure 11)** Remove the spacer making sure not to squeeze the brake lever.

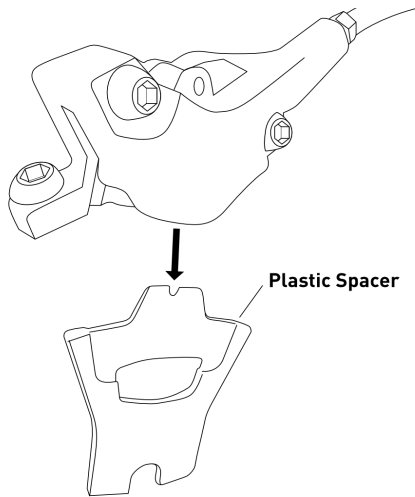

Figure 11: Brake Pad Spacer

Insert the wheel making sure that the disk rotor slides into the disk brake caliper between the two brake pads. **(Figure 10)** Holding the quick-release lever in the OPEN position with your left hand, tighten the Cap until it is finger-tight. While pushing the wheel firmly to the top of the slots in the frame dropouts, rotate the quick-release lever upwards and push it into the CLOSED position. If the lever cannot be pushed all the way to a position parallel to the frame with lever blade curvature toward the frame, return the lever to the OPEN position. Then, turn the cap counterclockwise one-quarter turn and try tightening the lever again.

CAUTION If you can fully close the quick release lever without wrapping your fingers around the fork blade for leverage, and if the lever does not leave an imprint in the palm of your hand, then the tension is insufficient. Open the quick-release lever and turn the cap clockwise a quarter turn, and then try again.

Test for proper installation. Spin the wheel to make sure that it is centered in the frame. Pick up the bike, and sharply hit the top of the tire with the heel of your hand. The wheel must not come off, be loose, or move from side to side.

WARNING Failure to properly adjust the quick release mechanism can cause the wheel to wobble or disengage. This could cause you to lose control and fall.

WARNING Improperly securing a wheel with a quick release skewer can cause the wheel to come off the bicycle.

Step 4 - Install Front Wheel

There are two main types of attachment systems for wheels: quick release and thru axle. While there are various types of thru axle systems, we will cover the most common types. If you do not see your axle in this manual, feel free to contact us.

The process for installation of a quick release front wheel is the same as the process for installation of a quick release rear wheel. Follow the instructions in Step 3.

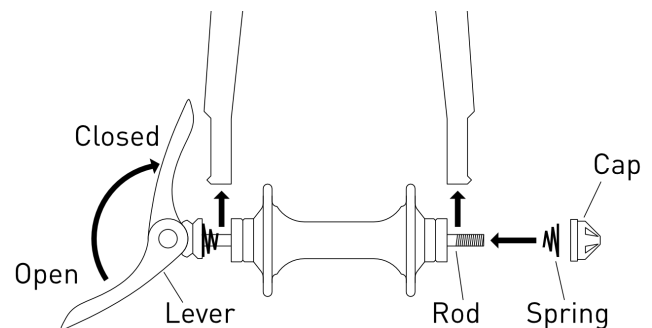

Figure 12: Front Quick Release Installation

The process for installation of a thru axle front wheel is almost the same as a thru axle rear wheel. Some thru-axle forks are equipped with a cam action lever similar to a quick release. Follow all instructions from the owner's manual of the fork manufacturer. Common fork thru-axle and installation procedures are shown in **Figure 13**.

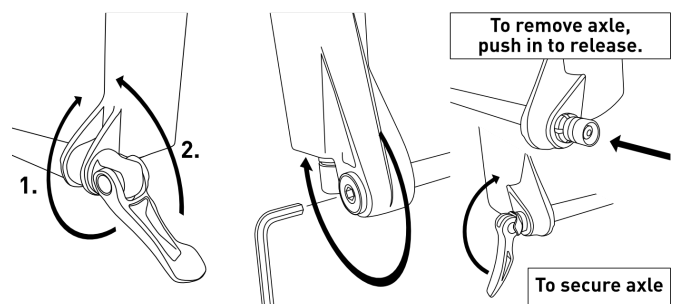

Figure 13: Thru Axle Types

Step 5 - Attach Seat

Insert Seatpost into Seat Tube. Insert the seatpost past the Seatpost Minimum Insertion Mark on seatpost and tighten securely. If your bike has a bolt-on seatpost clamp, tighten the bolt using the provided allen wrenches to 5 Nm. If your bike has a quick release seatpost clamp, secure it in the same way that you would secure a quick release lever on the wheel. Most quick release seatpost clamps use either a knurled nut that can be tightened by hand or a 4 mm or 5 mm bolt to set the tension for the cam action. If the seatpost clamp is integrated into the frame, tighten the bolt to 8 Nm. **(Figure 14)**

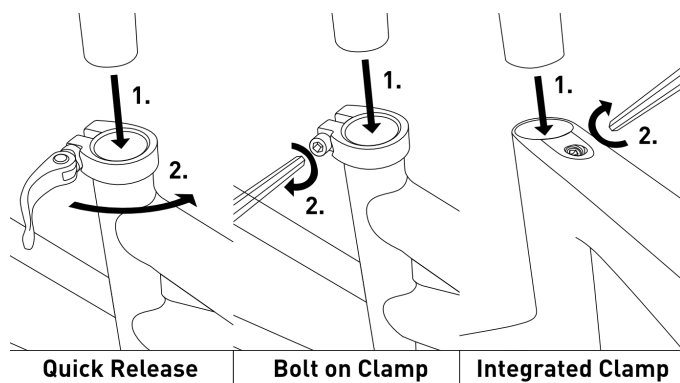

Figure 14 - Seatpost Installation

⚠ WARNING On bikes with quick release seatposts, you must use the full force of the cam action to clamp the seatpost securely. Turning the lever like a wing nut until it is tight will not clamp the seatpost safely.

⚠ WARNING Riding with an improperly tightened seatpost can allow the saddle to turn or move and cause you to lose control and fall.

Saddle Height Adjustment

Exact saddle height is largely a matter of personal preference. Below is a recommended way to adjust seatpost height.

1. Sit on the saddle in a riding position while someone holds the bicycle upright.
2. Position the crank arms so they are parallel to the seat tube.
3. Loosen the seatpost clamp bolt or quick-release.

4. Place your heel on the pedal and extend the seatpost until your leg is straight. Your hips should stay level. For proper riding position, when wearing shoes and with the ball of your foot on the pedal, you should have a slight bend in your knee. Your knee is usually bent between 27-37 degrees, depending on your individual flexibility.
5. Make sure the minimum insertion mark on the seatpost is not visible above the bike frame.
6. Re-tighten the seatpost quick-release, or bolt. For a seatpost binder with a quick-release lever, the mechanism works the same as a wheel quick-release. Adjust the lever tension, and make sure it is in the closed position.

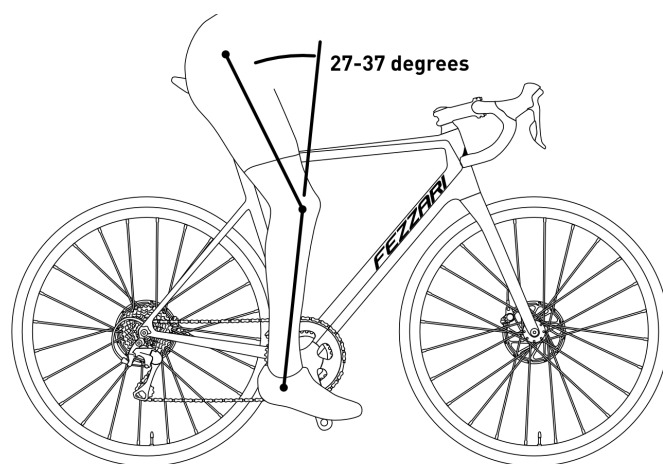

Figure 15 - Seat Height Position

Dropper Seatposts

Dropper seatposts are becoming more and more common on all bikes. There are a few differences that are important to note:

- Dropper seatposts require service. Make sure to wipe down the exposed stanchion with a rag after every ride. This will help prolong the life of the seals. Follow the manufacturer's suggested service protocol found in their owners manual.
- Dropper seatposts use a keyway system to keep the seat aligned with the frame. There may be a few millimeters of play left and right in the seatpost. This is normal.

The process to set up a dropper seatpost is largely the same with only a few notes of caution.

- Make sure that the seatpost is fully extended before setting the seatpost height. This is done by pressing the dropper lever without any weight on the seat.
- Never pull up on the dropper seat when the seat is compressed. Never hang a bike from a dropper seatpost that is not fully extended.

 CAUTION Pulling up on a dropper seatpost when it is compressed will interfere with the normal operation of the dropper seatpost. This can make the dropper seatpost malfunction causing you to lose control or fall.

Step 6 - Attach Pedals

There is a left and right pedal. Make sure to install the correct pedal on the correct side. Pedals have different threads based on which crank arm they connect to. Fezzari pedals are marked with “L” for left and “R” for right. Left and right are determined from the riding position on the bicycle. **(Figure 16)**

⚠ CAUTION Left and Right Pedals are threaded in opposite directions. Do not try to force the wrong pedal onto the crank arm as it will strip the threading. Always finger tighten first.

(1) Align the pedal axle with the threaded hole in its respective crank arm. Secure the pedal in the crank by hand. The right pedal is installed by turning the pedal axle clockwise and the left pedal is installed by turning the pedal axle counter-clockwise.

(2) After the pedals can no longer be turned by hand, use the proper tool included in your tool kit and tighten the pedals securely. Some pedals use a 15 mm open ended wrench to tighten the pedals, while others are tightened using a 6 mm or an 8 mm Allen wrench from the back side of the crank arm. The pedal should fit snugly against the crank arm.

⚠ WARNING Sometimes noises coming from your pedals are because you have not sufficiently tightened the pedal onto the crank. Riding with a pedal not sufficiently tightened can damage your crank and pedals or strip the threads and cause the pedals to come off. This can cause serious injury or death.

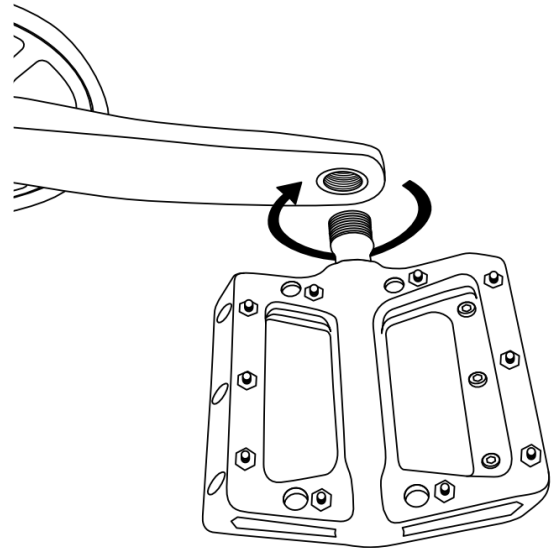

Right Pedal

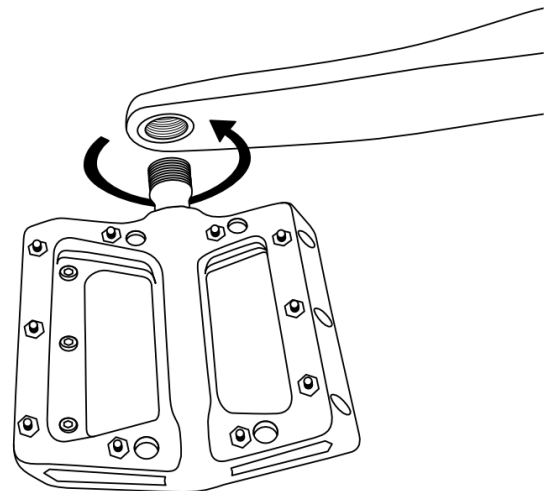

Left Pedal

Figure 16 - Pedal Installation

Step 7 - Inflate Tires

Check the inflation of the tires. In shipping, it is possible that tires may lose some pressure. Most tire manufacturers list the maximum pressure for their tires on the sidewall of the tire. Rims also have a maximum pressure specification. Tire pressure should not exceed what is indicated on the sidewall or by the rim manufacturer.

There are many variables to consider when choosing what pressure to inflate your tires to. These include: tire type, bicycle type, tire width, rider weight, tire casing thickness, riding conditions, etc. We cannot recommend a pressure that will work perfectly in all conditions, in all locations, or for all rider types, but here are some general guidelines for common tire sizes and their pressures:

Road

| Tire size | Pressure | Pressure when set up tubeless |
|-----------|-------------|-------------------------------|
| 700x23-25 | 100-110 psi | 85-95 psi |
| 700x28-32 | 80-90 psi | 65-75 psi |
| 700x32-40 | 60-70 psi | 45-55 psi |
| 700x45+ | 40-50 psi | 30-35 psi |

Mountain

| Tire size | pressure | Pressure when set up tubeless |
|---------------|-----------|-------------------------------|
| 27.5x2.1-2.4" | 28-35 psi | 22-28 psi |
| 27.5x2.8" | 20-24 psi | 18-22 psi |
| 29x2.1-2.4" | 28-35 psi | 22-28 psi |
| 29x2.6" | 25-30 psi | 20-25 psi |
| 26x4-5" | 10-20 psi | 6-18 psi |

CAUTION Inflate tires to the proper tire pressure for their intended use. Do not over-inflate.

Bicycle tires are inflated using either a Presta Valve or a Schrader Valve (**Figure 17**). Schrader valves have traditionally been the more popular valve, but more and more bicycles are using Presta Valves. The main advantages of a presta valve are:

- Smaller diameter valve which requires a smaller hole to be drilled into the rim, resulting in a stronger rim.
- Simpler valve that does not clog as easily.
- Valve core that is easily removable allowing easy insertion of sealant (when tubeless).

The Presta Valve functions by only allowing air to pass through the valve when the small locking nut has been unthreaded. This allows the valve to be active. To inflate or deflate a tire through a Presta Valve, you must unthread the small locking nut first. After changing your tire pressure, tighten the small locking nut to keep the valve securely closed.

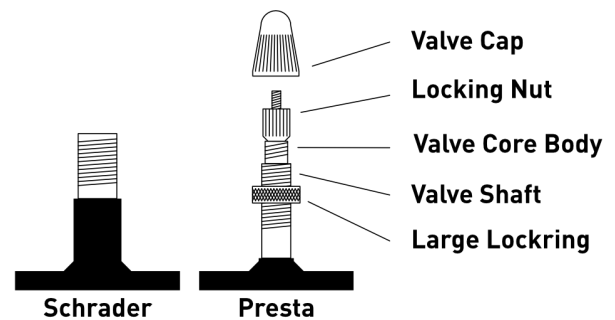

Figure 17: Tire Valve Types

Tubeless tires are another addition that is becoming more and more common on bicycles of all types. This system requires the use of both tires and rims that are specially made to be set up tubeless. The tire casings are non-porous and the rims have features that hold the tire bead in place more securely. The rim is taped to stop the leaking of any air through the spoke holes or seams. The tube is replaced with a valve core and sealant. Sealant is in place to seal any punctures that may occur. Since there are many different brands and types of sealant and several different standards when it comes to tubeless rim and tire interface, this manual only gives a basic description.

Section 2 - Operation

Operation

Before Riding

► **NOTE:** The information contained in this manual is to be used as guidelines for safe operation and is not intended to replace any safety rules or laws that may be in force in your area.

Before riding your Fezzari, make sure all quick releases are locked and secure. Make sure all parts, components, and accessories are in good working order. One way to remember the key things to check before every ride is to check the **ABCs: Air, Brakes, Chain***.

Air - Tubes, Tires and Wheels

- Make sure your tires are inflated to the pressure recommended by the manufacturer.
- Check the tire tread and sidewall for any damage. Replace damaged tires before riding.
- Make sure that the rims spin straight and that there isn't any damage. Slight wobbles can usually be trued by a qualified mechanic, while large wobbles may require replacement.
- Make sure the valve cap is installed correctly.
- Ensure that the wheels are securely attached to the frame. Check that the quick releases and/or thru axles are tight.

Brakes - Brake Levers, Calipers and Rotors

- Spin the wheel. Make sure that the brakes do not rub or slow the wheel down.
- Pull the brake levers. Make sure that the brakes engage before the lever gets closer than a fingers width to the bar.
- Make sure that the rim brake surface (if rim brake) or the disc rotor (if disc brake) is free from debris and shows no signs of cracks, warping, or concavity.
- Make sure the brake pads are in complete contact with the braking surface and not rubbing on the tire.

Chain - Chainrings, Cassette and Chain

- Make sure that your chain is lubed properly and does not squeak when you pedal.
- Check the chain for any broken or bent links and check the chainrings and cassette for any broken or bent teeth. Replace any parts that are bent or broken.
- Shift through all the gears. Listen for any grinding noises or gears that skip.
- Check the cables and housing, making sure there are no sharp kinks or rusty cables.

This is not an exhaustive list, but rather a starting point of things to check before a ride. Always check your equipment before riding. It is your responsibility to make sure that your bicycle is in proper working condition before use.

***ABC Quick Check used with permission from the League of American Bicyclists.**

⚠ WARNING Replace any worn or damaged parts before riding your bicycle.

⚠ WARNING Always ride with a certified CPSC-certified bicycle helmet.

While Riding

There are many factors that will influence wear and tear on your bicycle. Ultimately, it is your responsibility to maintain your bicycle in good working order. It is impossible to predict every single scenario that your bike will be in, but here are several guidelines concerning bicycle riding that will prolong the usable life of your bicycle and gear.

Braking - Bicycles mainly have 2 types of brakes: Rim Brakes and Disc Brakes. Both systems function on the same principles of friction. Rim brakes have brake pads that contact the surface of the rim to slow the bicycle down. Disc brakes have brake pads that contact the disc brake rotor to slow the bicycle down. There are some guidelines that apply to both brake systems and some only apply to one.

- It is good practice to use even amounts of front brake and rear brake. When you pull the brakes on a bicycle, your weight shifts forward, increasing the traction the front wheel has with the ground while decreasing the traction that the rear wheel has. Be aware of your center of gravity and shift your weight back under hard braking to make sure that you do not go over the front of your handlebars.
- Both disc brakes and rim brakes are susceptible to heat build-up due to friction. If you hold the brakes down during long descents and do not periodically let up on the brakes to let them cool down, they can generate excessive amounts of heat. When rim brakes get too hot, they can cause the tube to burst and you can lose control of the bicycle and crash. If the rim is carbon fiber, it can get hot enough to affect the composition of the resin used in the manufacturing process causing the rim to deform. This can cause you to lose control of the bicycle and crash. In disc brakes, the heat from friction is concentrated on the rotor and brake caliper. If the rotor gets too hot, the surface can glaze over, reducing stopping power, and producing more noise. In extreme cases, the caliper can get hot enough to affect the hydraulic brake fluid in the system.
- Make sure that your rims, rotors and brake pads stay free from contaminants. If you suspect they

are dirty or contaminated, clean them with a lint free rag and rubbing alcohol.

Shifting - Most bikes have gears, and gears allow you to climb and descend all types of terrain. There are a few simple rules that will help you to get the most out of your gear systems.

- **Most important:** If you suspect your derailleur has been bumped out of alignment, do not ride your bike until you are sure that it is aligned correctly. Riding a bike with a derailleur that is out of alignment can cause the spokes to catch the derailleur and pull it into the wheel. This can cause the wheel to lock up and make you lose control and crash. This can also damage many components including the frame. This is not considered a warranty scenario.
- If you have to set your bike down on its side, set it down with the right side facing up. This will ensure that the derailleur does not get bumped out of alignment. It does not take a lot of force to bend a derailleur hanger.
- While gear systems allow you to shift at will, momentarily pedaling at a slower cadence, or just pedaling more softly while you shift will allow the system to shift fully into a gear, causing less stress and strain on the drivetrain components. This may require practice, but shifting smoothly will greatly improve the lifetime of your chain, cassette, chainrings, and derailleurs.
- To prolong the life of the springs that keep the derailleur functioning, store your bike with the derailleurs shifted into the smallest cogs. This will result in lower chain tension and spring tension.
- If your bike has a front derailleur, there are many combinations of front chainring and rear cog positions, but there are some combinations that you should avoid. You should avoid shifting into the lower gears (larger cogs) in the rear when you are in the higher (larger) chainrings. Likewise, you should avoid shifting into the higher gears (smaller cogs) in the rear when you are in the lower (smaller) chainrings. This is commonly referred to as "cross-chaining." These gear combinations force your chain to engage from one extreme to the opposite extreme and will increase wear on your chain, cassette, and chainrings.

Tires - Here are some tips:

- Always ride with your tires properly inflated. Riding with tires that are not properly inflated will result in uneven wear. Too much pressure will wear down the center of the tire tread quicker, while too little pressure will accelerate sidewall wear and tear.
- When braking, do your best to avoid skidding or locking up the rear tire. Skidding or locking up the rear tire will wear it down unevenly, put flat spots in the tire, or even cause it to burst.

Riding Conditions - Even the conditions you ride in can have an effect on component wear. Mud, salt water, and excessive dust will have an affect on your bicycle and components. If possible, avoid riding in mud, salt water, and excessively dusty conditions. Since it is not always possible to avoid these conditions, if you do choose to continue, be prepared to thoroughly clean your bike afterwards to limit component wear.

Take care of your bike and it will last longer. Riding your bike in harsh environments, hard and aggressive jumps and drops, high mileage, and higher body weight will all contribute to a shorter lifespan and will require more maintenance. On the other hand, smooth, fluid riding in a clean environment, conservative riding, lower mileage and a lower body weight will all enable your bicycle to enjoy a longer lifespan.

 WARNING It is the responsibility of the rider to maintain your bicycle in good working order. Failure to replace any worn out or damaged parts can lead to that part's loss of function.

Section 3 - Maintenance

Maintenance

Fezzari bicycles are built with a high level of precision and require maintenance to continue to perform at high levels. Here are some maintenance recommendations.

► **NOTE:** When working on your bicycle in a repair stand, always clamp the seatpost in the clamp and never clamp the frame of the bicycle. This can damage the frame.

Cleaning

Regular and thorough cleaning of your Fezzari will keep it looking newer longer, protect the finish, and make it perform better. If your Fezzari gets dirty or muddy, prop your bike upright and spray it down with a hose. DO NOT use a pressure washer. High pressure water can get into the pedals, bottom bracket, or hubs, which could compromise the bearings, grease, and components inside. Use a bucket of warm water and mild soap or any other bicycle specific cleaning agents. Avoid using any harsh chemicals on your bike. Scrub the bike with a soft sponge, or a rag. Use a soft bristled brush for hard to reach spaces like the cassette or bottom bracket area. Rinse the bike off with clean water.

Make sure to re-lubricate parts afterwards; otherwise they may rust.

If you want to shine up your bike after washing, you can use any liquid car wax on your Fezzari.

⚠ WARNING Avoid getting any lubricant or grease on the braking surfaces such as rims and brake rotors. This may result in your brakes losing effectiveness which can lead to a crash.

Lubrication

A bicycle has several moving parts that must be lubricated regularly for optimal performance and to prevent rust and reduce wear. Use a light bicycle lubricant. Be careful to wipe off any excess lubricant, which can attract dirt and dust.

Lubricate the following regularly:

- Chain - while turning the crank backwards, apply a light coat. Let it sit for a minute, and then wipe off any excess. Depending on the chain lube you use and the conditions you ride your bike in, you should expect to lubricate your chain every 50-100 miles for a road bike, and every 25-50 miles for a mountain bike. Keeping your chain lubricated will lengthen its usable life.
- Any Pivots on Derailleurs and Brakes (places where parts move) - apply two to three drops of lubricant in these areas. Make sure to wipe off any excess.
- Pedals - if pedals seem stiff to rotate or make noise, apply lubricant on the moving parts and wipe off any excess.
- Any component that rotates, such as the headset, bottom bracket and hubs - there is grease inside these components that keeps them moving smoothly. If dirt or water gets inside any of these areas, it can cause the performance to deteriorate. The process to lubricate these components is usually more involved and you should consult each component's manual.

Use lubricants designed for bicycles. Some lubricants, especially penetrating lubricants, can displace the grease that is needed to keep the components moving smoothly.

Inspection

Check the tightness of key components. Put a wrench on every important bolt and tighten it slightly to see if it has loosened:

- Check seat and seatpost bolts
- Check wheel quick releases
- Check stem and handlebar bolts
- Check brake and shift lever bolts
- Check spoke tension (look for loose spokes)
- Tighten bolts that hold accessories (water bottle holders)
- Check suspension pivot bolts (if applicable)

Inspect your frame for any signs of damage.

- For an aluminum bicycle frame, check the welds for any cracks. Check the frame for any dents or dings from rocks.

- For a carbon fiber bicycle frame, check the frame for any cracks. Cracks on a carbon fiber bicycle can cause discoloration in the paint in the damaged area. Check for delamination of the fibers. Check the frame for any damage after a fall or crash.

If any damage is found, **do not** continue to ride the bicycle. Have a professional evaluate the damage and determine if the bike is safe to ride.

⚠ WARNING Riding a damaged bicycle is unsafe. Doing so will put extra strain on all of the systems in a bicycle and will accelerate wear on those systems.

Pedals

Make sure that your pedals are securely fastened to the cranks. Remember that the right pedal is regular-threaded (clockwise) and the left pedal is reverse-threaded (counter-clockwise)

▶ NOTE: An easy way to remember how to tighten your pedals is to rotate the pedal bolt towards the front of your bike.

If your pedals develop squeaks, do not ride your bike. Check to make sure that your pedals are correctly installed on the cranks. If they are tight, apply lubricant on the moving parts and wipe off any excess.

⚠ CAUTION Sometimes noises coming from your pedals are because you have not sufficiently tightened the pedal onto the crank. Riding with a pedal not sufficiently tightened can irreparably damage your crank and pedals and cause injury.

Wheels

Tires & Tubes

All bicycle tires are somewhat porous and allow air to seep out over time. Low tire pressure makes riding more difficult and can damage your rims, tires, and tubes. Low tire pressure can also cause your tires to wear out faster. Use a good pump with a built-in gauge and inflate it to the tire manufacturer's recommended pressure, located on the tire sidewall.

▶ NOTE: Inflate tires to the tire manufacturers recommended pressure, located on the tires sidewall, unless it is set up tubeless.

▶ NOTE: Tire pressure can decrease as much as 5 to 10 psi per week. Check tire pressure regularly. Ensure that the valve cap is installed correctly.

Spokes and Wheels

Check for loose spokes. To adjust spokes and wheels, take your bicycle to a certified bicycle mechanic.

Check the rim for any dents or bends. It is sometimes possible to true a rim if it is out of alignment due to an impact or crash, but it is always recommended to replace any part that has been damaged or bent in an impact or crash.

⚠ WARNING Loose spokes can cause a wheel to go out of true and collapse, rub on the frame or completely lock up.

Brakes

There are several types of brakes on a bicycle; rim brakes, disc brakes, drum brakes, and coaster brakes. This manual will cover the two most common types; rim brakes and disc brakes.

Common Rim Brake Adjustments

Over time it is common for cables to stretch and brake pads to wear down. Most bikes that have rim brakes are equipped with barrel adjusters to make small brake

adjustments. Barrel adjusters have a knurled edge for gripping, and can be adjusted without tools.

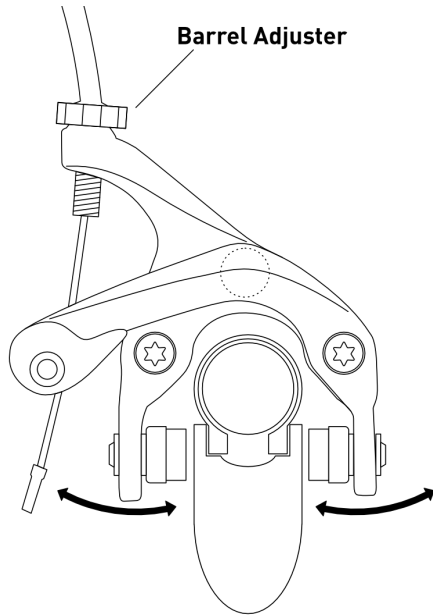

Figure 18 - Rim Brake Barrel Adjuster

To use the barrel adjusters, turn the adjusting barrel counterclockwise to decrease the distance the brake pads have to travel to contact the rim. If the brake pads are too close to the rim, turn the barrel adjuster clockwise by hand and check the setting by squeezing the levers (**Figure 18**).

If one brake pad is closer to the rim than the other brake pad, first check to make sure that the wheel is installed correctly in the fork or frame. If the wheel is properly installed, this can impact brake adjustments. Brakes can be adjusted using either a 13mm cone wrench or a 5 mm Allen wrench. Cone wrenches are made to fit in the narrow space where the brake mounts to the frame. Use the wrench to adjust the position of the brake caliper in the direction that is needed. If the brake does not have the option to adjust position using a 13 mm cone wrench, use the 5 mm Allen wrench to loosen the mounting screw, reposition the brake, and then tighten the mounting screw.

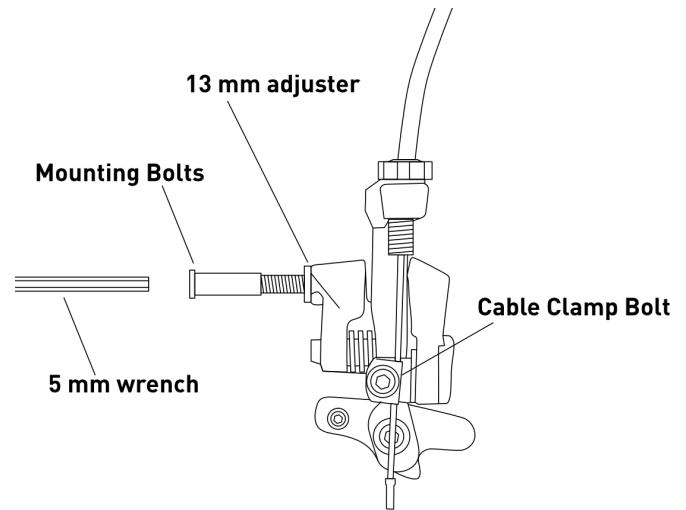

Figure 19 - Rim Brake Adjustments

When brake pads wear out, the barrel adjuster will not have enough adjustment built in to them to function correctly. You will need to turn the barrel adjusters all the way into the starting position (clockwise) and replace the brake pads. If the pads have not worn out yet, but the cable has stretched too far and you have run out of adjustment from the barrel adjuster, you will need to turn the barrel adjuster back to its starting position (clockwise), loosen the cable clamp bolt and tighten the cable (**Figure 19**).

For more information on adjusting and maintaining your brakes, please refer to the brake manufacturer's owners manual.

⚠ WARNING Improperly adjusting your brakes can cause them to malfunction and could result in serious injury.

Common Disk Brake Adjustments

Most modern disc brake systems use hydraulic fluid. Some less expensive disc brakes are cable actuated. For these brake adjustments, refer to the previous section on rim brake adjustments or the manufacturer's owners manual.

The adjustments in this system vary and depend on the brake model and manufacturer. Most brakes have the option to adjust the brake lever reach. This is usually a small bolt near the brake lever pivot. Turning this bolt will either move the brake lever further out or closer to the handlebar. This will not adjust the position of the brake

pads or pistons, this will only change the distance the lever starts from the handlebars.

Hydraulic disc brakes generally self-adjust. As your brake pads wear down, the system adjusts the pistons closer to the rotor to make up for the thinner brake pads. If the brake pad is rubbing on the rotor, it is sometimes possible to easily adjust the caliper. The disc brake caliper is mounted to the frame using either two 4 mm bolts, two 5 mm bolts, or two T25 torx bolts (**Figure 20**). To re-center the disc brake caliper over the rotor, loosen the two mounting bolts a half turn each. Pull the brake lever and continue to hold it closed while you tighten down the two mounting bolts. This method will work if the brakes are not too far out of alignment. If this does not work, consult a qualified bicycle mechanic.

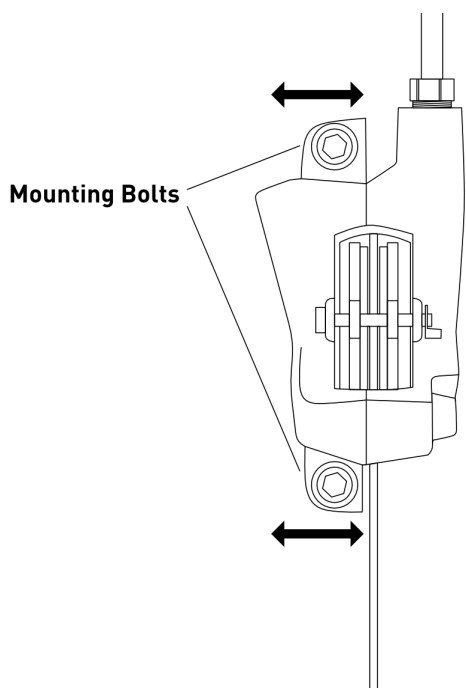

Figure 20 - Disc Brake Mounting Bolts

⚠ WARNING Only use clean rags or cloths and cleaners that do not leave residue, such as rubbing alcohol, to clean your brake rotors. Using any other substance can contaminate your brake pads or rotors and compromise your ability to slow down or stop your bicycle causing you to fall or crash.

Brake Pads

Brake pads will wear down faster or slower depending on several factors:

- The way in which the brakes are used.

If you use your brakes constantly when going downhill, the brake will get hotter and wear out more quickly. It is best to let up on your brakes periodically while riding downhill to let them cool down. Hard, heavy braking will wear the brake pads down faster.

- The conditions in which the bike is ridden.

Brakes are meant to slow your bicycle down in any condition, but some conditions will wear down the brake pads faster. Riding in muddy, wet or sandy conditions will accelerate the wear of the brakes.

- The material the brake pads are made out of.

With both rim brakes and disc brakes, it is possible to install brake pads of different materials. The softer the brake pad, the more initial bite it will have. However, softer brake pads will wear out more quickly. Harder brake pads will not have as strong an initial bite but will last longer. Harder brake pads might also introduce more noise into the system.

Gears

Though it may seem simple, the shifting system on a bicycle is a finely calibrated system that requires a certain level of precision to function. If it needs adjustment, for best results consult a qualified mechanic. Do not adjust anything if you are unsure of what you are doing. You assume all responsibility for any adjustments that you make to your bike.

► **NOTE:** We have provided a small summary of the different functions of the adjustments on the shifters and derailleurs that are installed on your bicycle. Because the system is interconnected, the problems are not always straight-forward and the solutions included here cannot cover every possible problem.

► **NOTE:** In this section and other sections, when referring to the gears, “High Gears” refers to the gears intended for higher speeds, and “Lower Gears” refers to the gears intended for lower speeds.

There are 3 main adjustments that can be made to the shifting and derailleur system; Derailleur Hanger Alignment, Cable Tension, and Limit Adjustment.

Derailleur Hanger Alignment

It is important to know the symptoms of a bent rear derailleur hanger because riding a bicycle with a bent derailleur hanger can lead to broken spokes, derailleurs, and even the frame. Your derailleur hanger may be bent if:

- the gears shift well when on the higher gears, but start to shift poorly and skip over gears when shifting into the lower gears.
- the gears shift well in some gears, but shift poorly in others.
- the gears shift well before a crash and start to shift poorly after a crash.
- it appears bent when you look at it.

If you suspect your rear derailleur hanger is bent, do not ride the bicycle. Do not attempt to straighten the hanger yourself. It should be replaced or adjusted with a Derailleur Hanger Alignment Gauge before you ride it again.

Cable Tension

A derailleur with cable tension issues will shift poorly in all or almost all gear combinations. The only adjustment that you can make to the cable is more or less tension. You can adjust the cable tension one of two ways: by either using the barrel adjuster, or using the cable attachment bolt.

The cable attachment bolt should be viewed as a larger less precise adjustment, while the barrel adjuster is for smaller more precise adjustments. Road bicycles will usually have the barrel adjuster located on the derailleur itself, while mountain bicycles will usually have the barrel adjuster located on the shifter. For rear derailleurs, increasing cable tension will move the derailleur into a lower gear. For front derailleurs, increasing cable tension will move the derailleur into a higher gear.

To increase the cable tension, turn the barrel adjuster counter clockwise. If the barrel adjuster reaches the end of its adjustment, it will be necessary to adjust the cable using the cable attachment bolt. First, turn the barrel

adjuster all the way clockwise, then loosen it one full turn. Next, undo the cable attachment bolt, pull more cable through and clamp the cable under the cable attachment bolt. Once the cable is secured, continue using the barrel adjuster to fine tune the cable tension.

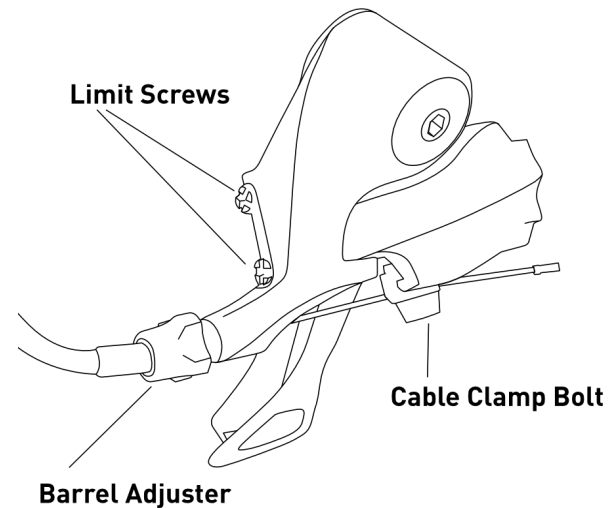

Figure 21 - Rear Derailleur Adjustments

To decrease cable tension, turn the barrel adjuster clockwise. If the barrel adjuster reaches the end of its adjustment, it will be necessary to adjust the cable using the cable attachment bolt (**Figure 21**). First, turn the barrel adjuster all the way clockwise, then counter clockwise one full turn. Next, undo the cable attachment bolt, pull more cable through and clamp the cable under the cable attachment bolt. Once the cable is secured, continue using the barrel adjuster to fine tune the cable tension.

Rear Derailleur Troubleshooting

Rear derailleur cable needs more tension if:

1. Difficulty or hesitation shifting into a lower gear.
2. Chain does not stay in the selected gear and moves towards or catches on a higher gear.
3. System will not shift into the lowest gear. (May also be low limit screw adjustment)

Rear derailleur cable needs less tension if:

1. Difficulty or hesitation shifting into a higher gear.

2. Chain doesn't stay in the selected gear and moves towards or catches on a lower gear.

3. System will not shift into the highest gear. (May also be high limit screw adjustment)

Many front derailleurs have more shift positions/shift stops than they have gears. These extra shift positions are trim tabs (for small adjustments when riding). If your chain is making noise in a certain gear, shift one click either way on the front derailleur. If your bicycle is equipped with a front derailleur, please consult the derailleur manufacturer's manual and familiarize yourself with this function.

Front Derailleur Troubleshooting

Front derailleur cable needs more tension if:

1. Difficulty or hesitation shifting into a higher gear.
2. Chain doesn't stay in the selected gear and moves towards or catches on a lower gear.
3. System will not shift into the highest gear. (May also be limit screw adjustment)

Front derailleur cable needs less tension if:

1. Difficulty or hesitation shifting into a lower gear.
2. Chain doesn't stay in the selected gear and moves towards or catches on a higher gear.
3. System will not shift into the lowest gear. (May also be limit screw adjustment)

Limit adjustment

Both front derailleurs and rear derailleurs have limit screws to limit the range of motion. Most derailleurs will have these screws close together and will have markings to indicate H for high limit screw and L for low limit screw.

The High limit screw will limit the movement of the derailleur when it is in the highest gear. If this screw is too tight, the derailleur might have difficulty shifting into the highest gear. If this screw is too loose, the derailleur might push the chain further than the highest gear. In the case of the front derailleur, this pushes the chain off the outside of the chainring and towards the right pedal. In the case of the rear derailleur, this pushes the chain off the highest gear and into the frame.

The low limit screw will limit the movement of the derailleur when it is in the lowest gear. If this screw is too tight, the derailleur might have difficulty shifting into the lowest gear. If this screw is too loose, the derailleur might push the chain further than the lowest gear. In the case of the front derailleur, this pushes the chain off the inside of the chainring and towards the frame. In the case of the rear derailleur, this pushes the chain off the lowest gear and into the spokes. If the low limit screw is not adjusted properly, the chain and derailleur can get caught in the spokes. This can damage the spokes, hub, chain, derailleur and the frame, causing you to lose control and crash. Do not adjust the limit screws if you are unsure of what you are doing. You assume all responsibility for any adjustments that you make to your bike.

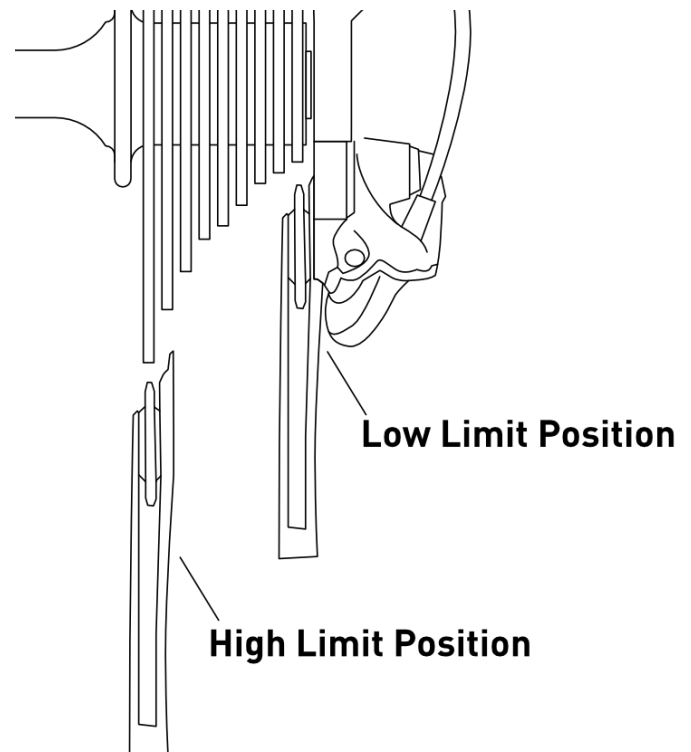

Figure 22 - Limit Positions

⚠ CAUTION Do not ride with your chain on either the smallest front gear and smallest rear gear, or with your chain on the largest front gear and largest rear gear. This can cause undue wear on the chain and gears, excess noise, and inefficient pedaling.

Suspension Fork Adjustment & Maintenance

Please refer to the suspension manufacturer's owner's manual for suspension maintenance and adjustment.

► NOTE: For most suspension components, a supplemental owners manual from the suspension manufacturer is included with this manual. Please refer to that manual for adjustments and maintenance. **OUR SUGGESTIONS BELOW DO NOT OVERRIDE ANYTHING STATED IN THOSE MANUALS.**

⚠ CAUTION Please refer to the supplemental owner's manual for your suspension components before changing any settings or doing any maintenance.

General Suspension Adjustments

Your Fezzari suspension has already been adjusted to your specific measurements and for normal riding conditions.

Since suspension adjustments and types vary by manufacturer, we will only give a brief description of the function of each adjustment

Spring rate/air pressure

Most suspension uses air pressure for the spring. This has the benefit of being more adjustable across a broader range of rider weights and being lighter weight. Air sprung suspension requires the use of a bicycle specific high pressure shock pump. Do not use any other pump to put air into your fork or shock.

It is common for the fork manufacturer to include a recommended air pressure chart printed on the lower left fork leg. If your fork is an air sprung fork, but does not

have a chart printed on the lower left fork leg, consult the fork manufacturer's owner's manual.

Consult the supplemental manual that is specific to your bicycle for a chart to set up the air pressure in the rear shock.

We recommend using 30% sag as a starting point on our bicycles. Sag refers to the amount the suspension compresses under the riders weight when compared to the full travel of the fork or shock. When dealing with the fork, sag is measured when the rider is in a "standing, ready for descent" riding position. When adjusting the sag in the rear shock, sag is measured when the rider is in a seated position. To achieve more sag, decrease the pressure in the fork or shock using a shock pump. To achieve less sag, increase the pressure in the fork or shock using a shock pump.

If your bicycle is equipped with a coil sprung shock, we have chosen the spring rate that matches the suspension kinematics of your bike and your rider weight. Small adjustments can be made to fine tune the feel of the coil spring by turning the knurled adjustment ring on the coil clockwise to increase the spring rate slightly and counter-clockwise to decrease the spring rate slightly. If you have any additional questions, consult the shock manufacturer's owner's manual.

Rebound

Rebound adjust is a feature on most suspension components. Rebound refers to how fast the suspension returns to its fully-extended state. This is often a red knob labeled "fast — — slow" or in some cases shows simple images depicting a turtle and a rabbit. In most cases, turning the rebound knob clockwise will slow the rate at which the suspension returns to its fully-extended state, while turning the rebound knob counter-clockwise will speed up the rate at which the suspension returns to its fully extended state. Rebound is dependent on the air pressure/spring rate. Riders with higher pressures/stiffer spring rates will have to turn the dial clockwise to achieve the same rebound rate. Consult with the suspension manufacturer's owner's manual for recommendations on rebound rate for the specific air pressure/spring rate your suspension is set at.

Low Speed Compression

Low Speed Compression (LSC) controls the movement of the suspension in regards to body input. This is the

feeling you get when you sit on the bike and the bike supports your weight. Simply put, more low speed compression will give the bike a more supportive feeling at the expense of some small bump sensitivity. Less low speed compression will remove some of that supportive feeling, but give the bike more sensitivity to small bumps.

High Speed Compression

High Speed Compression (HSC) adjusts the movement of the suspension in regards to trail input. This is the feeling of the suspension quickly absorbing an impact. Simply put, more High Speed Compression gives the fork a more harsh feeling when you encounter an obstacle in the trail, but is less likely to blow through all the available travel. Less High Speed Compression will allow the suspension to move through its travel more quickly, but too little high speed compression can cause the suspension to reach the end of its travel resulting in more harsh bottom-outs.

Lockout

The lockout feature on many suspension components is a simple valve that shuts off the flow of oil inside the suspension. It can be an on-off lever, a lever with 3 positions, or a knob with multiple adjustments. This will stiffen up the feel of the suspension and in some cases, stop the suspension from moving altogether.

► **NOTE:** not all lockouts will stop the suspension from moving completely. When locked out, most suspension will still allow a slight movement so that the internal components of the suspension can be protected.

CAUTION Use caution and refer to the supplemental fork manufacturers owners manual before adjusting any screws.

Suspension Service Intervals

Suspension components use very precise seals and o-rings. These need to be serviced over time to ensure the continued performance of your suspension. Check with the manufacturer's owner's manual for the exact riding time you should expect between services. You should expect to service your suspension at least one time a year.

Storage

Always store your Fezzari indoors. The indoor environment will protect the bike from moisture in outside air that over time will corrode the metal parts. It will also protect your Fezzari from extended exposure to sunlight, which can cause the paint to fade and tires to rot, or salt if you live near an ocean, which can accelerate rust and corrosion. Even when storing your bike indoors, we recommend you lock your bicycle to something solid. If you are storing your bicycle for a long period of time, switch the gear to the smallest chainwheel and the smallest sprocket. This relaxes the cables and springs as much as possible so that their strength and structural integrity does not degrade over time.

CAUTION Do not hang your mountain-bike upside down by both wheels because this may cause the oil in the front shock to separate

Care for your Fezzari

Your Fezzari was made with high performance components, and is highly durable. You can ride hard, but ride smart. Learn to ride with a light technique as some of the best bikers do and your Fezzari's usable life will be extended. Experts ride smoothly so you barely hear noise. This will save you time in maintenance, greatly reduce your chance of injury, and ensure that your bike will run trouble free much longer.

FEZZARI LIMITED WARRANTY

A. Warranty Information

FEZZARI BICYCLE LIMITED LIFETIME WARRANTY

Fezzari warrants the frame and rigid fork of each new Fezzari brand bicycle and Fezzari brand frameset to be free from defects in material and workmanship for as long as the original purchaser owns the bicycle. Paint finish and all other original components, and all Fezzari brand repair parts, replacement parts, and accessories, are warranted to be free from defects in material or workmanship for a period of one year from the original date of purchase.

LIMITED REMEDY

Unless otherwise provided, the sole remedy under the above warranty, or any implied warranty, is limited to the replacement of defective parts with those of equal or greater value at the sole discretion of Fezzari. You will be responsible for labor costs associated with warranty replacements. IN NO EVENT SHALL FEZZARI BE RESPONSIBLE FOR DIRECT, INCIDENTAL OR CONSEQUENTIAL DAMAGES, INCLUDING, WITHOUT LIMITATION, DAMAGES FOR PERSONAL INJURY, PROPERTY DAMAGE, OR ECONOMIC LOSSES, WHETHER BASED ON CONTRACT, WARRANTY, NEGLIGENCE, PRODUCT LIABILITY, OR ANY OTHER THEORY.

EXCLUSIONS

THE ABOVE WARRANTY, OR ANY IMPLIED WARRANTY, DOES NOT COVER NORMAL WEAR AND TEAR. ALL WARRANTIES ARE VOID IF THE BICYCLE IS MODIFIED FROM ITS ORIGINAL CONDITION OR THE BICYCLE IS USED FOR OTHER THAN NORMAL ACTIVITIES, INCLUDING, BUT NOT LIMITED TO, FAILING TO FOLLOW THE OWNER'S MANUAL OR USING THE BICYCLE FOR COMMERCIAL ACTIVITIES OR IN COMPETITIVE EVENTS, INCLUDING BUT NOT LIMITED TO BICYCLE RACING, BICYCLE MOTOCROSS RACING, STUNT RIDING, RAMP JUMPING OR SIMILAR ACTIVITIES, AND TRAINING FOR SUCH ACTIVITIES OR EVENTS. FEZZARI MAKES NO OTHER WARRANTIES, EXPRESS OR IMPLIED. ALL IMPLIED WARRANTIES, INCLUDING THE WARRANTIES OF MERCHANTABILITY AND FITNESS FOR A PARTICULAR PURPOSE, ARE LIMITED IN DURATION TO THAT OF THE EXPRESS WARRANTIES STATED ABOVE.

WHAT YOU SHOULD DO

Contact Fezzari Customer Support
<https://www.fezzari.com/contact>.

SUPPORT

Fezzari Contact Information

For all current contact information, please visit us at www.fezzari.com.

Questions? Problems? Contact us at:
<https://www.fezzari.com/contact>.