

# WOOL AND THE GANG

#MADEUNIQUE

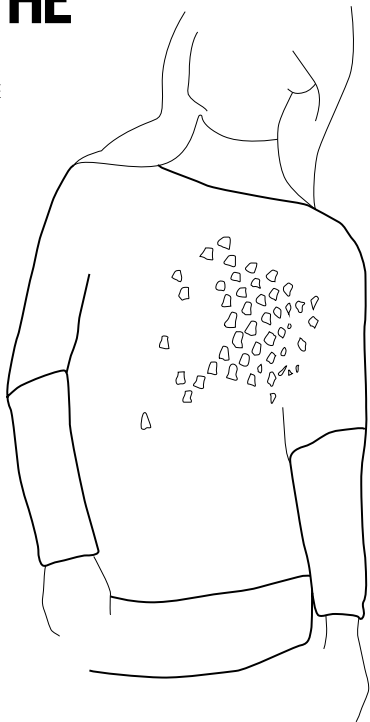

## PHOEBE PONCHO

INTERMEDIATE

6.5MM CROCHET HOOK

6.5MM (US10.5) KNITTING NEEDLES

© Wool and the Gang LTD. 2019

# YOUR ADVENTURE STARTS NOW



## IT'S FUN

Making is the new yoga. Free your mind, the rest will follow. Namaste.

## WE'LL BE THERE FOR YOU

Find all the video tutorials you need online.

## YOU'RE GOING TO FEEL GOOD

Nothing will make you happier than holding your finished project.

# RECIPE FOR SUCCESS

1

## **GET YOUR TOOLS READY.**

Everything you need to get making.

---

2

## **FAMILIARISE YOURSELF WITH THE TECHNIQUES.**

Everything from the stitches used to the finishing touches for your project.

---

3

## **GET TO KNOW YOUR YARN.**

Before you start your piece, play around with your new yarn to get used to it, and to check your tension.

---

4

## **WOOL SCHOOL**

Pick up your needles & yarn and make the magic happen! For a little extra help, check out our Wool School at:

**[www.woolandthegang.com/t/how-to](http://www.woolandthegang.com/t/how-to)**

---

5

## **#WOOLANDTHEGANG**

When you're done - let the world know.

# LET'S GET KNITTING

## Tool kit

- 6[7:7:8:8:8] balls of WATG's Shiny Happy Cotton
- 1 Phoebe Poncho pattern
- 1 6.5mm crochet hook
- 1 pair of 6.5mm (US10.5) knitting needles
- 1 sewing needle

## Tension

To ensure your crochet project has the same measurements as the pattern, it is a good idea to make a tension swatch before you start. A tension swatch is a small sample of crochet where you count the stitches and rows and check them against the tension given in the pattern. If you get MORE stitches/rows than the pattern's tension, it means your crochet is TIGHTER. If you get FEWER stitches/rows than the pattern, your crochet is LOOSER. Sometimes, it works to crochet tighter or looser to compensate.

### Openwork crochet pattern

10cm/4" = 13 stitches

10cm/4" = 6 rows

### 1x1 Rib stitch (knitted)

10cm/4" = 20 stitches

10cm/4" = 16 rows



**Help's only a stitch away.** Watch the video tutorials online at [www.woolandthegang.com/t/how-to](http://www.woolandthegang.com/t/how-to)

**All techniques can be found at the back of the pattern.**

## SIZING

The pattern includes directions for 6 sizes. When the instructions differ between sizes, information is given for size 1 first, then for sizes 2 - 6 in brackets, separated by a colon. (example: size 1[size 2:size 3:size 4:size 5:size 6].)

You might want to highlight your size before you get started!

	<b>SIZE 1</b>	<b>SIZE 2</b>	<b>SIZE 3</b>	<b>SIZE 4</b>	<b>SIZE 5</b>	<b>SIZE 6</b>
<b>TO FIT CHEST CM/”</b>	80-86 / 32-34	88-96 / 36-38	100-108 / 40-42	112-118 / 44-46	122-128 / 48-50	132-140 / 52-54”
<b>UK</b>	6-8	10-12	14-16	18-20	22-24	26-28
<b>US</b>	2-4	6-8	10-12	14-16	18-20	22-24
<b>EU</b>	34-36	38-40	42-44	46-48	50-52	54-56
<b>IT</b>	38-40	42-44	46-48	50-52	54-56	58-60
<b>AUS</b>	6-8	10-12	14-16	18-20	22-24	26-28
<b>ASIA</b>	7-9	11-13	15-17	19-21	23-25	27-29

Pssst! Remember that you must not copy our patterns and sell, or even give them away for free, in accordance with copyright law.

# MEASUREMENTS: SIZES 1 & 2

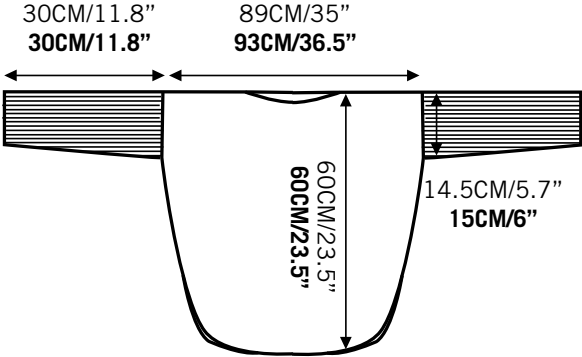

## MEASUREMENTS: SIZES 3 & 4

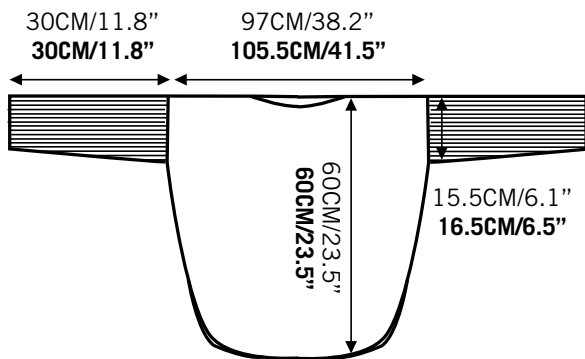

## MEASUREMENTS: SIZES 5 & 6

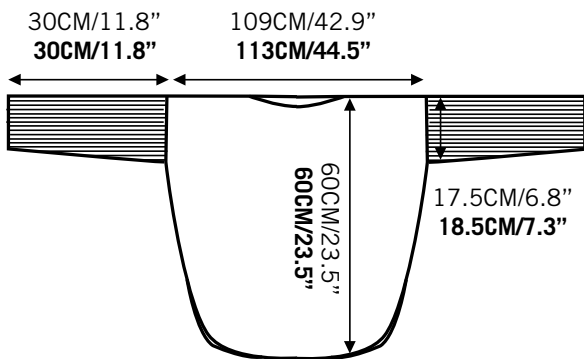



# HOW TO CROCHET YOUR PHOEBE PONCHO

This poncho combines knitting and crochet. The front and back are crocheted as flat pieces, and the sleeves are knitted. The separate pieces are then joined together.

## BACK

1 Make a foundation chain of 57[62:67:77:82:87] chain stitches.

---

2 Make 3 chain stitches (this is your turning chain). Starting in the 4th chain from your hook, work 1 double crochet stitch into each of the next 2 stitches.

★Make 2 chain stitches, skip the next 2 stitches, work 1 double crochet stitch into each of the next 3 stitches.★

Repeat the section inside the stars to the end of the row. Turn your work.

---

3 **Increase row:** Make 3 chain stitches. Work 2 double crochet stitches into the 1st stitch.

★Make 2 chain stitches, work 3 double crochet stitches into the next chain space.★

Repeat the section inside the stars until you have 3 stitches left of your row. Make 2 chain stitches, skip 2 stitch, work 3 double crochet stitches into the last stitch of the row (the first time you work this step, this will be

---

the 3rd chain stitch of the turning chain you made in step 2). (62[67:72:82:87:92] stitches.)

---

- 4 Make 5 chain stitches. (this will create your first chain space).

★Work 3 double crochet stitches into the next chain space, make 2 chain stitches.★

Repeat the section inside the stars until you have 3 stitches left of your row, work 1 double crochet stitch into the last stitch of your row.

---

- 5 Make 3 chain stitches. Work 2 double crochet stitches into the first chain space.

★Make 2 chain stitches, work 3 double crochet stitches into the next chain space.★

Repeat the section inside the stars to the end of the row.

---

- 6 Repeat steps 3 to 5 once more. (67[72:77:87:92:97] stitches.)
- 

- 7 **Increase row:** Make 3 chain stitches. Work 2 double crochet stitches into the 1st stitch.

★Make 2 chain stitches, work 3 double crochet stitches into the next chain space.★

Repeat the section inside the stars until you have 3

---

stitches left of your row. Make 2 chain stitches, skip 2 stitch, work 3 double crochet stitches into the last stitch of the row (the first time you work this step, this will be the 3rd chain stitch of the turning chain you made in step 2). (72[77:82:92:97:102] stitches.)

---

**8** Make 5 chain stitches. (this will create your first chain space).

★Work 3 double crochet stitches into the next chain space, make 2 chain stitches.★

Repeat the section inside the stars until you have 3 stitches left of your row, work 1 double crochet stitch into the last stitch of your row.

---

**9** **Increase row:** Make 5 chain stitches. Work 3 double crochet stitches into the first chain space, make 2 chain stitches.

★Work 3 double crochet stitches into the next chain space, make 2 chain stitches.★

Repeat the section inside the stars until you have 1 chain space left of your row, work the following sequence into the last chain space: work 3 double crochet stitches, chain 2 stitches, work 1 double crochet stitches. Turn your work. (77[82:87:97:102:107] stitches.)

---

**10** Repeat step 5 once more.

---

**11** Repeat steps 7 to 10 a further 4 times.  
(117[122:127:137:142:147] stitches.)

---

**12** Make 5 chain stitches. Work 3 double crochet stitches into the first chain space, make 2 chain stitches.

★Work 3 double crochet stitches into the next chain space, make 2 chain stitches.★

Repeat the section inside the stars until you have 3 stitches left of your row, work 1 double crochet stitch into the last stitch of your row.

---

**13** Make 3 chain stitches. Work 2 double crochet stitches into the first chain space.

★Make 2 chain stitches, work 3 double crochet stitches into the next chain space.★

Repeat the section inside the stars to the end of the row.

---

**14** Repeat steps 12 and 13 until your piece measures 60cm from the foundation chain. (Approx. a further 7 rows.)

---

**15** Pull on the loop on your crochet hook until the end pops through. You have now secured the last stitch.

## FRONT

1 Follow steps 1 to 11 as given for the back.

---

2 Make 5 chain stitches. Work 3 double crochet stitches into the first chain space, make 2 chain stitches.

★Work 3 double crochet stitches into the next chain space, make 2 chain stitches.★

Repeat the section inside the stars until you have 3 stitches left of your row, work 1 double crochet stitch into the last stitch of your row.

---

3 Make 3 chain stitches. Work 2 double crochet stitches into the first chain space.

★Make 2 chain stitches, work 3 double crochet stitches into the next chain space.★

Repeat the section inside the stars to the end of the row.

---

4 Repeat steps 2 and 3 twice more.

Next, you will shape the neck.

---

5 Make 5 chain stitches.

★Work 3 double crochet stitches into the next chain space, make 2 chain stitches.★

---

Repeat the section inside the stars a further 8[8:9:10:10:10] times. Make 1 more chain stitch, make a slip stitch into the 1st stitch of next chain space. Work a slip stitch into each of the next 20[25:20:20:25:30] stitches.

Make 3 chain stitches.

Repeat the section inside the stars a further 9[9:10:11:11:11] times.

Make a double crochet stitch into the last stitch of the row.

- 
- 6** Pull on the loop on your crochet hook until the end pops through. You have now secured the last stitch.

## **SLEEVE**

Follow the instructions twice to make your sleeves.

- 1** With 6.5mm knitting needles, cast on 38[40:42:46:50:54] stitches using the long-tail cast on technique.
- 
- 2** Starting with a wrong-side row, work 13 rows in 1x1 rib stitch.
- 
- 3** **Increase row:** Knit 1 stitch, increase 1 stitch, work in 1x1 rib stitch until you have 1 stitch left of your row, increase 1 stitch, purl 1 stitch. (40[42:44:48:52:56] stitches.)

- 4 Knit 2 stitches, work in 1x1 rib stitch, until you have 2 stitches left of your row, purl 2 stitches.
- 
- 5 Repeat step 4 twice more.
- 
- 6 **Increase row:** Knit 1 stitch, increase 1 stitch, work in 1x1 rib stitch until you have 1 stitch left of your row, increase 1 stitch, purl 1 stitch. (42[44:46:50:54:58] stitches.)
- 
- 7 Work 1 row in 1x1 rib stitch.
- 
- 8 Repeat steps 3 to 7 a further 5 times. (62[64:66:70:74:78] stitches.)
- 
- 9 Work 4 rows in 1x1 rib stitch.
- 
- 10 Cast off loosely.

## ASSEMBLY AND FINISHING

- 1 Place the front and back together with the wrong sides touching.
- 
- 2 Use the whip stitch technique to sew the shoulders together.

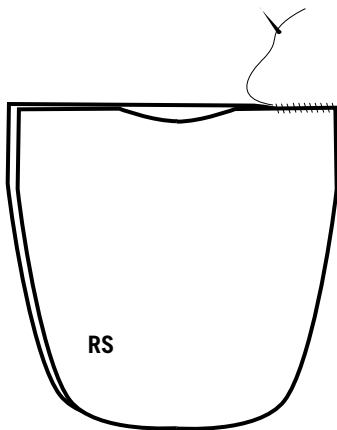

- 3 Place the sewn-together body of your poncho flat, with the right side facing up. Line up the centre of the cast off edge of your sleeve with the shoulder seam.
- 
- 4 Using the whip stitch technique, sew the sleeve to the body of your poncho - be sure to have the neat side of the cast on facing up.



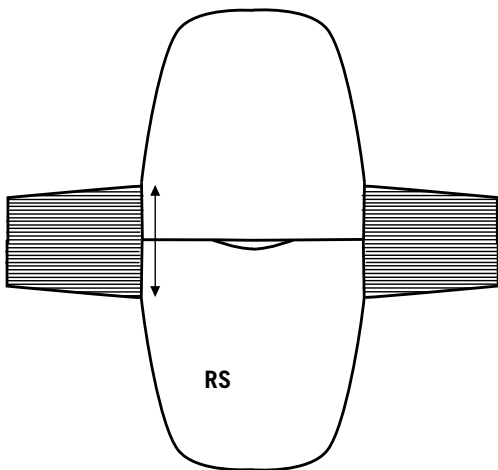

- 5** Repeat steps 3 and 4 for the other sleeve.

---

- 6** Fold your poncho in half along the shoulders and sleeves.

---

- 7** Use the vertical invisible seam technique to sew the underarm seam. Repeat for the other sleeve.

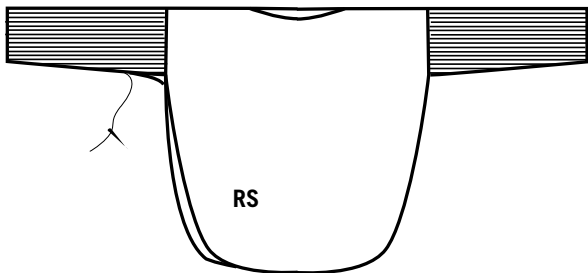

Next, you will join the side edges of the front and back using a decorative crochet join.

---

- 8** Leaving a gap of 18cm/7" from the bottom edge, make a slipknot 15cm/6" from the cut end of the yarn and hold it at the back of your work. Insert your crochet hook through the stitch, from the right side through to the back. Now pick up the slipknot with the hook and pull it through to the right side of your fabric.
- 

- 9** Make 2 chain stitches, make a slip stitch into the corresponding stitch on the other piece.

★ Make 2 chain stitches, make a single crochet stitch into the next chain space on the other piece. ★

Repeat the section inside the stars until you have joined the sleeve to the body. Make 2 chain stitches, make a slip stitch into the last stitch of the other piece, make 2

chain stitches, make a slip stitch into the last stitch of the other piece. Cut the yarn and secure the last stitch.

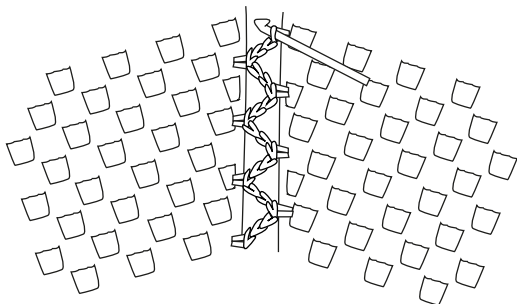

- 10** Repeat for the other side.
- 

Next, you will be working in single crochet around the edges of your poncho.

---

- 11** Starting at one of the side vents, work in single crochet all the way around the bottom edge of your poncho. Cut your yarn 15cm/6" from the last stitch. Pull on the loop on your crochet hook until the end pops through.
- 
- 12** Starting at one of the shoulder seams, work in single crochet all the way around the neck edge. Cut your yarn 15cm/6" from the last stitch. Pull on the loop on your crochet hook until the end pops through.
- 
- 13** Finish off by weaving in any loose ends.
-

# CROCHET TECHNIQUES



Help's only a stitch away. Watch the video tutorials online at [www.woolandthegang.com/videos](http://www.woolandthegang.com/videos)

## Crochet hook

The crochet hook is your tool on the path to greatness! Your pattern may refer to different parts of the crochet hook - here is an illustration to help you understand it all a little better.

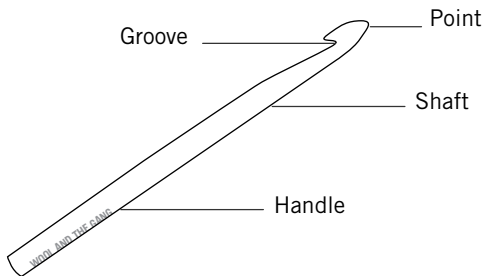

## Turning chains / [Online video tutorial](#)

When working in crochet, you often need to do a 'turning chain' at the beginning of your row. This creates a stitch that 'lifts' you up to the next level, so you're ready to crochet the next row. The turning chain is made up of chain stitches, and the number of stitches varies between different types of stitches. (Your pattern will tell you how many stitches to use for the stitch you're working in.)

## Chain stitch / [▶ Online video tutorial](#)

This is the foundation of most crochet work and can also be used as a technique on its own.

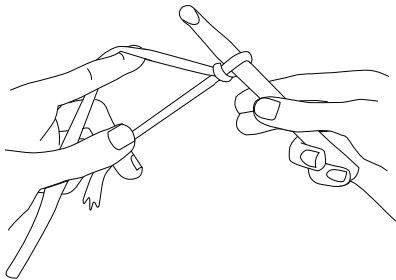

1. Make a slipknot and place it on the shaft of your crochet hook. Hold the hook in your right hand and the yarn in your left hand.

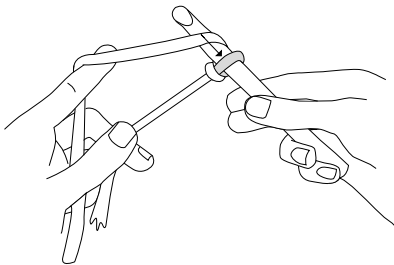

2. Move the point of the crochet hook **UNDER** the yarn from left to right, then move it **OVER** the yarn from right to left. The yarn is now looped around your crochet hook.

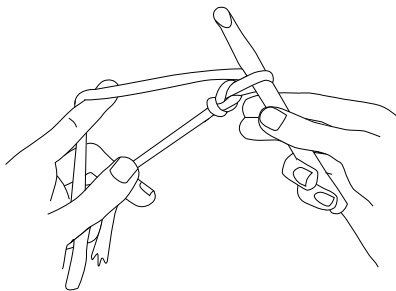

3. Scoop up the yarn with the groove of the hook, and pull it through the loop already on your hook. Slide the new stitch towards the shaft of the hook. You've now made one chain stitch.

Repeat steps 2 and 3 to keep creating new stitches. Take care not to pull your stitches too tightly! When counting your stitches, count each of the loops except the one on your hook.

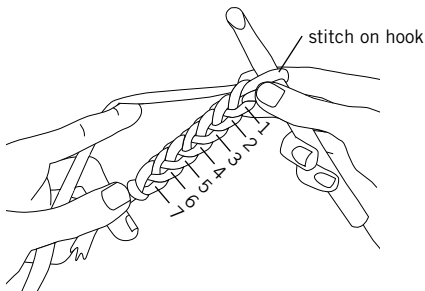

To make a chain stitch in the main body of your piece (for example, to make a turning chain), repeat steps 2 and 3.

## Single crochet / [▶ Online video tutorial](#)

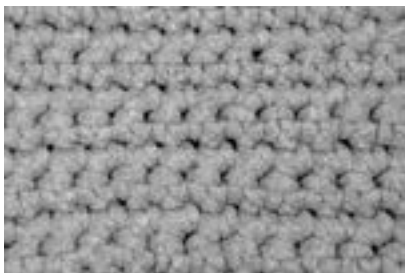

This stitch is one of the most basic crochet stitches. It uses a turning chain of 1 stitch.

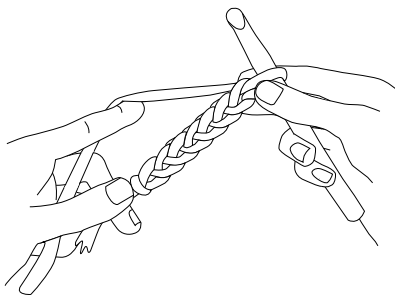

To work into a foundation chain at the beginning of your work, start with the hook in your right hand and the work in the left. Work across the foundation chain from right to left.

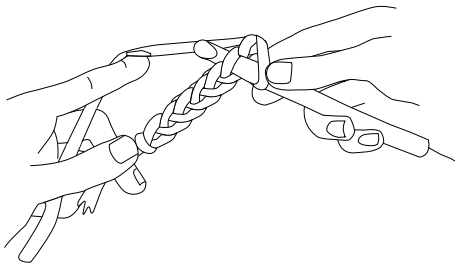

1. Insert the crochet hook into the middle of the second stitch from the hook (not counting the stitch on the hook!).

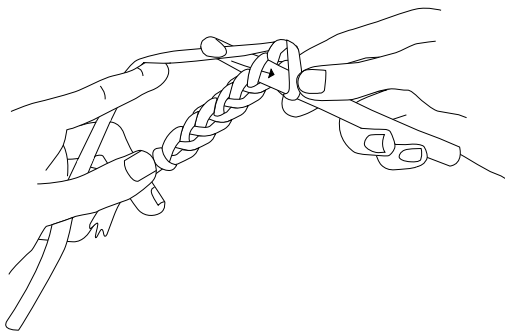

2. Move the hook under and then over the yarn. Scoop the yarn with the groove of the hook, and pull it through the stitch. There are now two loops on the hook.



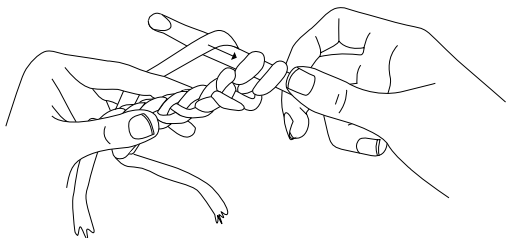

3. Loop the yarn around the hook again, and pull the yarn through BOTH of the loops on the hook. You have now worked one stitch in single crochet, and there's a single stitch on the hook again.

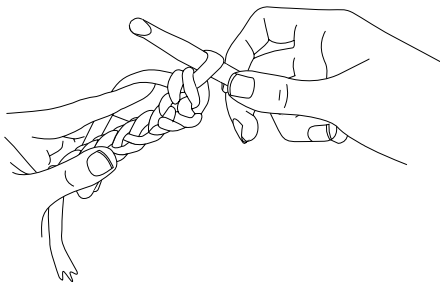

4. To continue working in single crochet, insert the hook into the next stitch of your row and repeat steps 2 and 3.

## Double crochet / [▶ Online video tutorial](#)

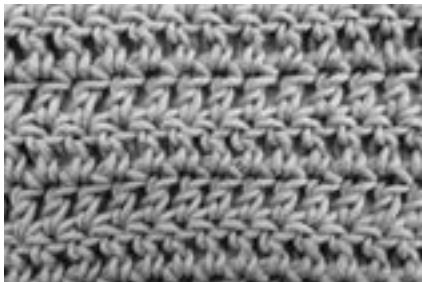

This stitch is a taller version of single crochet. It uses a turning chain of 3 stitches.

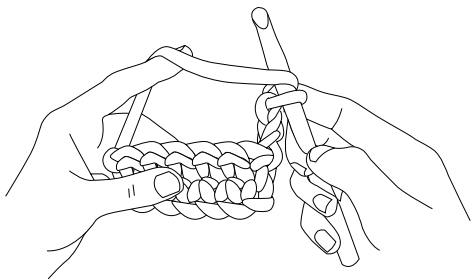

1. Make 3 chain stitches (this is your turning chain). Starting with the hook in front of the yarn, move the hook underneath the yarn, and then over it, so the yarn ends up looped around the shaft of the hook.

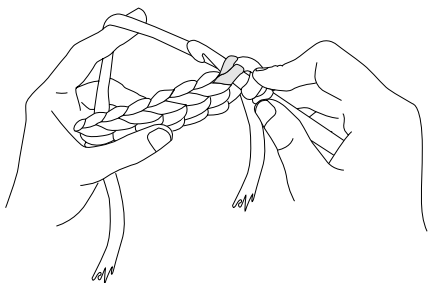

2. Insert the hook into the middle of the next stitch, underneath both strands of the sideways 'V' at the top.

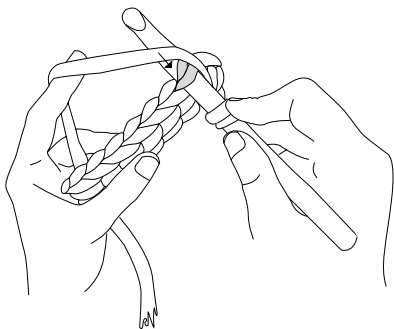

3. Loop the yarn around the groove of the hook, and pull it through the stitch and up onto the shaft of the hook. There are now three loops on your hook.

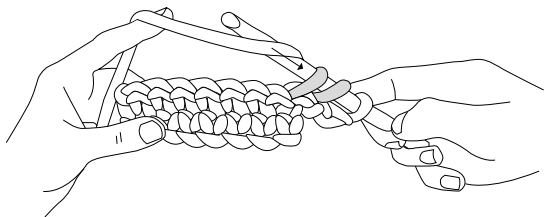

4. Loop the yarn around the hook again, and pull the yarn through two of the three loops on your hook. You now have two loops left on your hook.

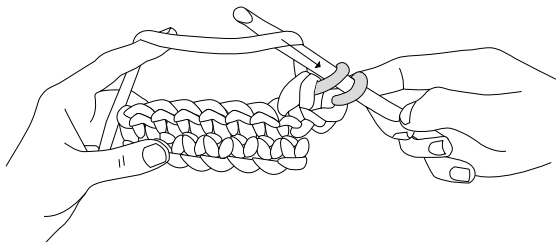

5. Loop the yarn around your hook once more and draw through BOTH of the loops on your hook. There is now a single loop left on your hook and you have worked one stitch in double crochet.
6. To continue working in double crochet, loop the yarn around the hook again, and repeat steps 2 to 5.

## Openwork crochet pattern

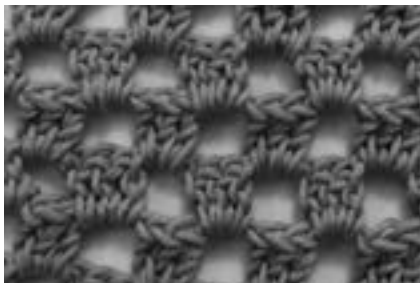

This stitch pattern is made up of double crochet and chain spaces. Start by making a foundation chain of a multiple of five stitches, plus two stitches.

- 1 Make 3 chain stitches. Work 1 double crochet stitch into the 4th stitch from the hook, then work the next stitch in double crochet.

★ Make 2 chain stitches, skip the next 2 stitches, work 1 double crochet stitch into each of the next 3 stitches. ★

Repeat the section inside the stars to the end of the row.

---

- 2 Make 5 chains stitches (this is your turning chain and will create your first chain space). Work 3 double crochet stitches into the next chain space.  
★ Work 2 chain stitches, work 3 double crochet stitches into the next chain space. ★
-

Repeat the section inside the stars until you have 3 stitches left of your row. Make 2 chain stitches, work 1 double crochet stitch into the last stitch of the row (the 3rd stitch of the turning chain).

---

**3** Make 3 chain stitches. Work 2 double crochet stitches into the first chain space.

★ Make 2 chain stitches, work 3 double crochet stitches into the next chain space. ★

Repeat the section inside the stars to the end of the row.

---

To continue working in the stitch pattern, repeat steps 2 and 3.

### **Chain spaces**

On the first row, you create the 'space' by skipping stitches in your row and instead working some stitches in chain stitch - this creates a loop in your crochet. On the next row, instead of inserting your hook into stitches in the regular way, you insert your hook into the space between the chain of stitches and the row below, so the chain ends up being covered by the new stitches.

### **Slip stitch / [▶ Online video tutorial](#)**

Insert your crochet hook into the next stitch. Starting with the hook in front of the yarn, move the hook under and then over the yarn, so the yarn ends up looped around the shaft of the hook. Scoop up the yarn with the groove of your hook and pull it through both the stitch and the loop on your hook. You now have a single loop on your hook. You have worked one slip stitch.

### **Adding a new ball of yarn / [▶ Online video tutorial](#)**

To add a new ball of the same colour, start your stitch in the regular way, but stop before working the final wrap-around (for single crochet: insert the hook, loop your yarn, pull the yarn through and then stop!) At this point, loop your new yarn around the hook, leaving a long tail of the new yarn, and pull the new yarn through the remaining two loops to finish the stitch.

### **Single crochet as decorative edging**

On the foundation chain edge and the last row you worked, insert your hook underneath the sideways 'V's in the regular way, loop the yarn around the hook and pull it through. Make a chain stitch, then work anti-clockwise in single crochet around your piece. On side edges, insert the crochet hook into the space between the rows or 'knots'.

### **Long-tail cast on (knitting) / [▶ Online video tutorial](#)**

This creates a nice elastic edge, suitable for stretchy items like hats. To make sure that the edge isn't too tight, you can cast on over two knitting needles held together.

1. Start by making a slipknot - the 'yarn tail' needs to be quite

long for this cast on, hence the name! Place the slipknot on your knitting needle, and hold the needle in your right hand, with the yarn hanging straight down.

2. Now insert the thumb and index finger of your left hand between the two strands of yarn hanging from the needle, and then close your ring finger and little finger around the yarn to trap it.

Stretch out your thumb and index finger as far from each other as possible, stretching the yarn taut.

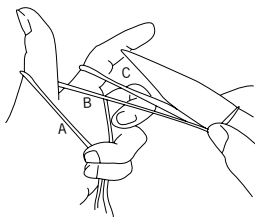

3. You will be using three separate strands of yarn:

A: the strand which sits closest to you, in front of the thumb

B: the strand that goes from the thumb to the slipknot on the needle

C: the strand that goes from the needle to your index finger



4. Place the needle in front of A, then bring it under A and let it come up between A and B.

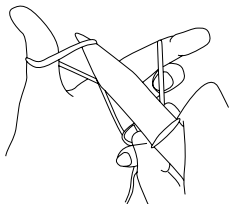

5. Now bring the needle over and behind C, and scoop the yarn (C) up with the tip of your needle.

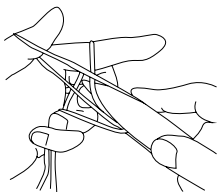

6. Bring the needle tip with the yarn back between A and B (the same way you came before), so that it ends up in front of A. Now pull your thumb out from the yarn that's looped around it. Tug on the yarn to tighten up the new loop on your knitting needle, then insert your thumb again between the two yarn strands hanging down from the newly formed loop on your needle.

7. Repeat steps 4-6 to continue casting on stitches.

## 1 x 1 Rib stitch (knitting) / [▶ Online video tutorial](#)

Knit the first stitch, purl the next. Continue alternating between knit and purl stitches to the end of your row. When working over an even number of stitches, repeat this row to continue working in 1x1 rib stitch.

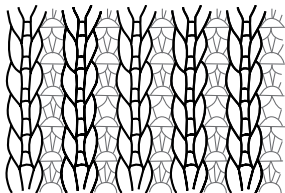

## Casting off (knitting) / [▶ Online video tutorial](#)

To complete your project, you need to cast off your last row of stitches in order to make an edge that won't unravel. For your final row, knit the first two stitches. Using the tip of the left needle, lift the first stitch up and over the second stitch and then slip it off the right needle. Now you have only one stitch on your right needle. Knit the next stitch from the left needle, then lift the previous stitch over it and off the needle as before. Do this with each stitch until there are no stitches on the left needle and just one stitch on the right needle. Cut the yarn, leaving a 15 cm/6" end. Pull on the last loop until the end pops through - you've now secured the last stitch.

## FINISHING TECHNIQUES

### Whip stitch

This is a simple way of joining two pieces of crochet.

Place the two crocheted pieces together with the right sides facing you.

1. Thread your sewing needle with a strand of yarn, and secure it to the wrong side of the fabric.
2. Insert your sewing needle through the first stitch of your row and, working from the inside of your piece to the outside, pull the yarn through your first piece.
3. Insert your sewing needle into the next stitch in your second piece of fabric, and push it back from outside to inside. Pull the yarn through.
4. Move back to your first piece and work from inside to outside once more.
5. Continue in this way until your seam is done.

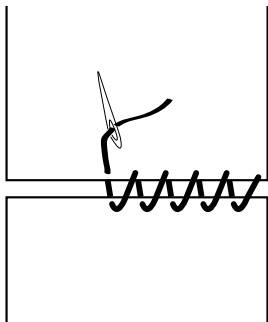

## Vertical invisible seam

This technique is used to join two side edges. Line up the edges side by side with the right side of the fabric facing up. Insert your sewing needle under the first horizontal bar between the first two stitches on the edge you want to join. Pull the yarn through and insert the needle through the opposite horizontal bar on the other piece. Sew back and forth through the horizontal bars along the edge. To tighten the stitches, pull the yarn gently - and they will disappear.

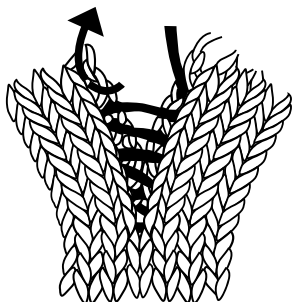

## Hiding your yarn ends

To hide the tail of your yarn, turn your work so the wrong side is facing you. Thread your sewing needle with the yarn end, and sew horizontally across your work, inserting needle and yarn underneath the back two strands of your crocheted stitches. Work like this for a few stitches, then move down a row and work back in the opposite direction. Finally, cut the yarn close to the fabric.

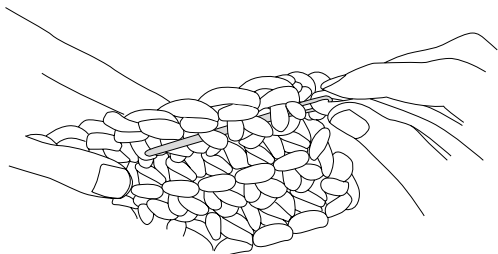

# MAKING MEMOIRS

STARTED ON .....

FINISHED ON .....

WHERE I MADE IT

- .....

- .....

- .....

MADE FOR

Me     .....

COLOUR COMBO .....

THIS PROJECT WAS

( ) easy peasy ( ) nice ( ) challenging ( ) hardcore

I FEEL    

OTHER THOUGHTS .....

.....





**1"**

**2"**

**3"**

**4"**

**5"**







**5 CM**

**10 CM**



**Wool and the Gang**



**@woolandthegang**



**@woolandthegang**



**WATGsnaps**



**Wool and the Gang**



**woolandtheganghq**

# YOUR PROJECT DESERVES SOME SEXY YARN

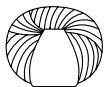

## CRAZY SEXY WOOL

100% Peruvian Wool

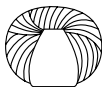

## HEAL THE WOOL

100% Recycled Wool



## LIL' HEAL THE WOOL

100% Recycled Wool



## JERSEY BE GOOD

98% Cotton  
2% Elastane



## MIXTAPE YARN

80% Cotton  
20% Polyester



## BILLIE JEAN

100% Upcycled Denim



## TAKE CARE MOHAIR

78% Kid Mohair  
13% Wool / 9% Polyamide



## FEELING GOOD

70% Baby Alpaca  
7% Merino / 23% Nylon



## SHINY HAPPY COTTON

100% Peruvian  
Pima Cotton



## SUGAR BABY ALPACA

100% Baby Alpaca



## TINA TAPE YARN

100% Tencel®

[WWW.WOOLANDTHEGANG.COM](http://WWW.WOOLANDTHEGANG.COM)

#  
**WOOL  
AND THE  
GANG**

V632054828

