

EMMA TANK

INTERMEDIATE
INTERMÉDIAIRE
FORTGESCHRITTEN



SHINY HAPPY
COTTON



3.5MM (US4)



5MM (US8)



5MM (US8)

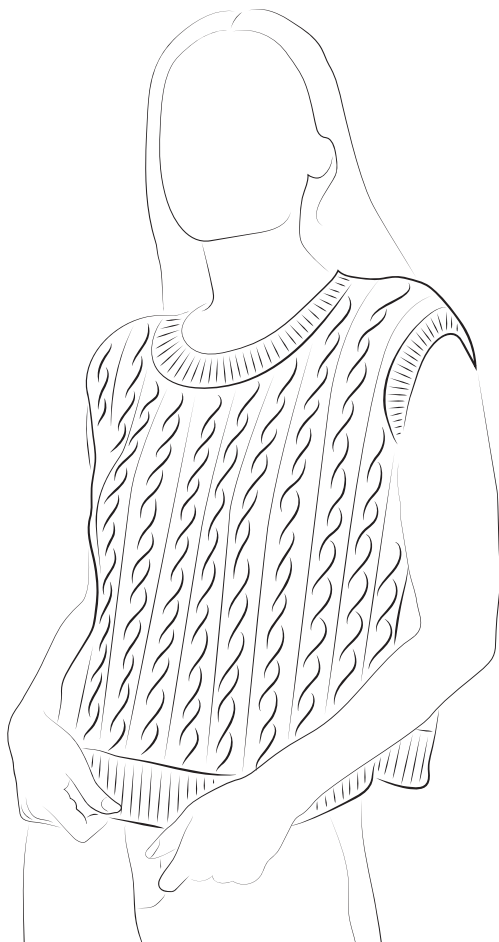

WOOL AND THE GANG

#WOOLANDTHEGANG
WOOLANDTHEGANG.COM

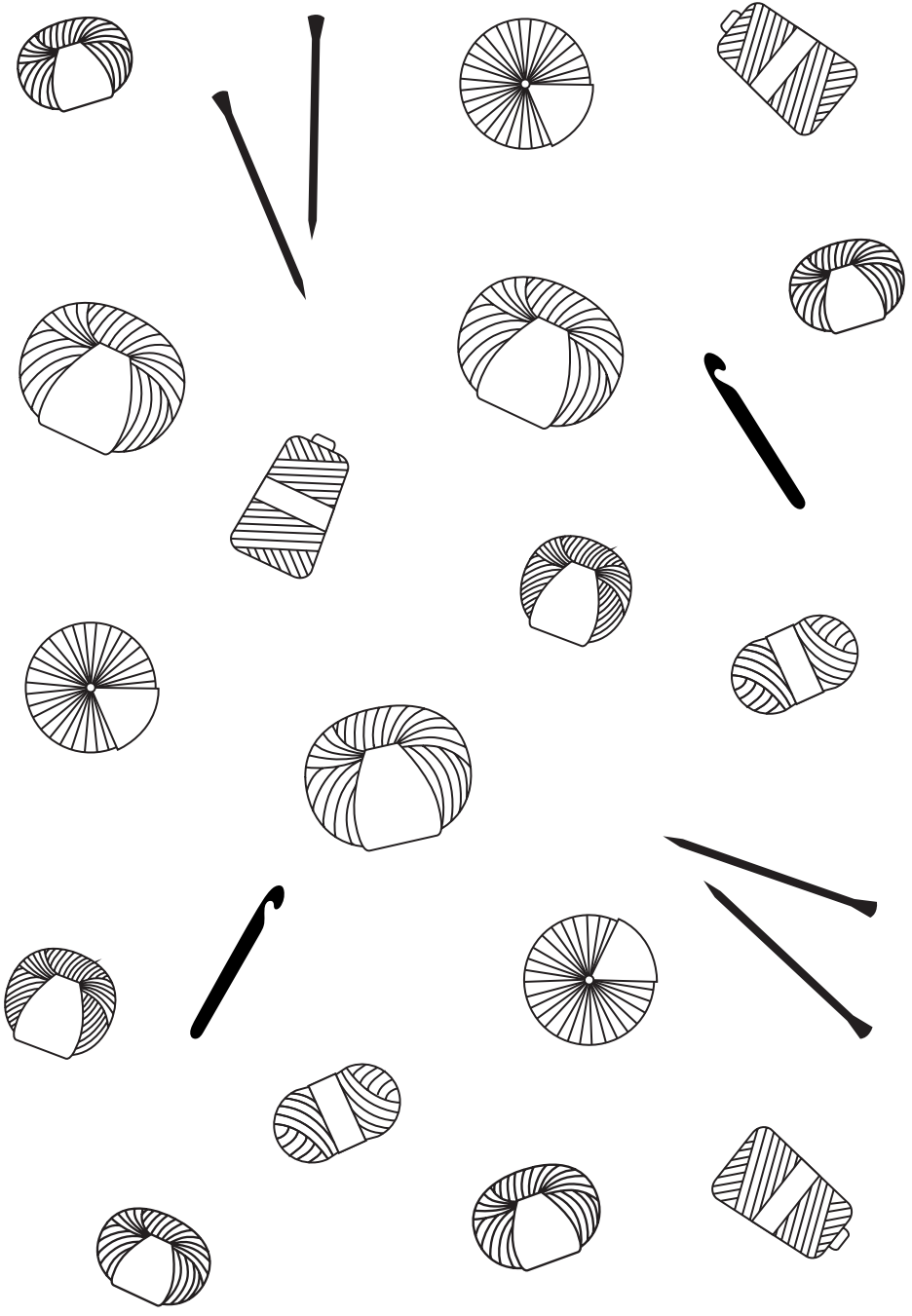

CONTENTS

GETTING STARTED

COMMENCER / *LOS GEHT'S*

4 YOUR ADVENTURE STARTS NOW

L'AVENTURE COMMENCE ICI ET
MAINTENANT

DEIN ABENTEUER BEGINNT JETZT

6 MEASUREMENTS

DIMENSIONS

MASSE

10 KNIT CODE

CODE TRICOT

STRICKCODE

ENG

PATTERN GUIDE

12 TOOL KIT

13 THE PATTERN

26 THE FINISHING

TECHNIQUES

28 KNITTING TECHNIQUES

32 FINISHING TECHNIQUES

YOUR ADVENTURE STARTS NOW

1 GET YOUR TOOLS READY Everything you need to get started.

PRÉPAREZ VOTRE MATÉRIEL

Assurez-vous de disposer de tout ce dont vous avez besoin pour votre projet.

BEREITE DEINE MATERIALIEN VOR

Suche alles zusammen, was du für dein Projekt benötigst.



2 FAMILIARISE YOURSELF WITH THE TECHNIQUES

Everything from the stitches used to the finishing touches for your project.

FAMILIARISEZ-VOUS AVEC LES DIFFÉRENTES TECHNIQUES

En commençant par les points utilisés jusqu'à la touche finale du projet.

MACH DICH MIT DEN TECHNIKEN VERTRAUT

Lies hier alles über die zu benutzenden Maschen, Muster und Techniken.

3 GET TO KNOW YOUR YARN

Before you start your piece, play around with your new yarn to get used to it, and to check your tension.

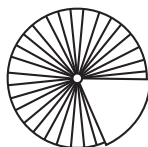

DÉCOUVREZ VOTRE LAINE

Avant d'entamer votre projet, découvrez votre laine pour vous y habituer et tester votre tension.

LERNE DEIN GARN KENNEN

Mach dich mit deinem Garn vertraut, bevor du mit deinem Projekt beginnst, und vergiss nicht die Maschenprobe!

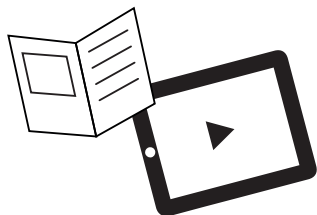

5 #WOOLANDTHEGANG

When you're done - let the world know.

Une fois votre projet terminé, partagez-le avec le monde entier !

Und wenn du fertig bist, ... zeig's der ganzen Welt!



4 WOOL SCHOOL

Pick up your tools & yarn and make the magic happen! For a little extra help, check out our Wool School.

Prenez votre pelote et vos outils, et que la magie opère ! Besoin d'aide ? Découvrez notre Wool School.

Nimm deine Werkzeuge und dein Garn und vollbring Wunder! Für ein wenig Hilfe besuch unsere Wool School.

▶ woolandthegang.com/videos

MEASUREMENTS

The pattern includes directions for 4 sizes. When the instructions differ between sizes, information is given for size 1 first, then for sizes 2 - 4 in brackets, separated by a colon. (example: size 1 [size 2:size 3:size 4].)

You might want to highlight your size before you start making!

DIMENSIONS

Ce patron contient les instructions pour 4 tailles. Lorsque les informations diffèrent pour les tailles, les instructions sont d'abord données pour la taille 1, puis pour les tailles 2 à 4 entre crochets, séparées par des points-virgule (exemple : taille 1 [taille 2; taille 3 ; taille 4]).

Pensez à surligner votre taille avant de tricoter !

MASSE

In der Anleitung findest du Angaben für 4 Größen. Dort, wo sich die Angaben voneinander unterscheiden, findest du zuerst die Anleitung für Größe 1 und dahinter die für Größe 2-4 in Klammern, welche wiederum mit Doppelpunkten voneinander getrennt sind (Beispiel: Größe 1 [Größe 2 : Größe 3 : Größe 4]).

TIP: Markiere dir die Angaben für deine Größe mit einem Textmarker, um dich besser zurecht zu finden.

SIZE / TAILLE / GRÖSSE

TO FIT CHEST
TOUR DE POITRINE
BRUST WEITE

UK

US

EU

IT

AUS

ASIA

1	2	3	4
81-86 32-34"	91-97 36-38"	102-107 40-42"	112-117 44-46"
6-8	10-12	14-16	18-20
2-4	6-8	10-12	14-16
34-36	38-40	42-44	46-48
38-40	42-44	46-48	50-52
6-8	10-12	14-16	18-20
7-9	11-13	15-17	19-21

I + 2

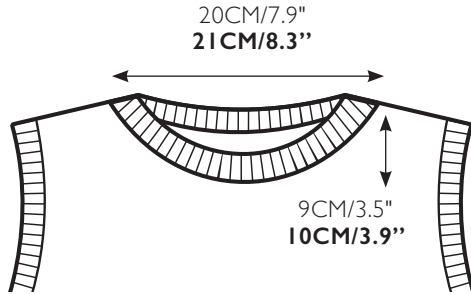
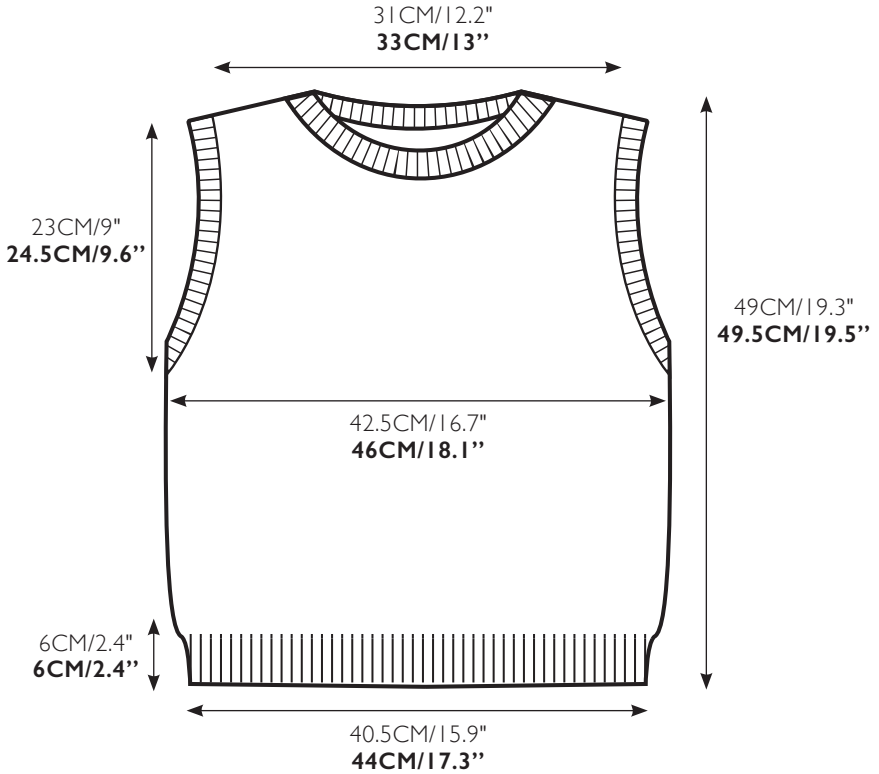

3 + 4

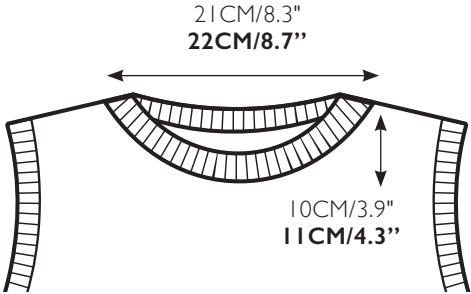
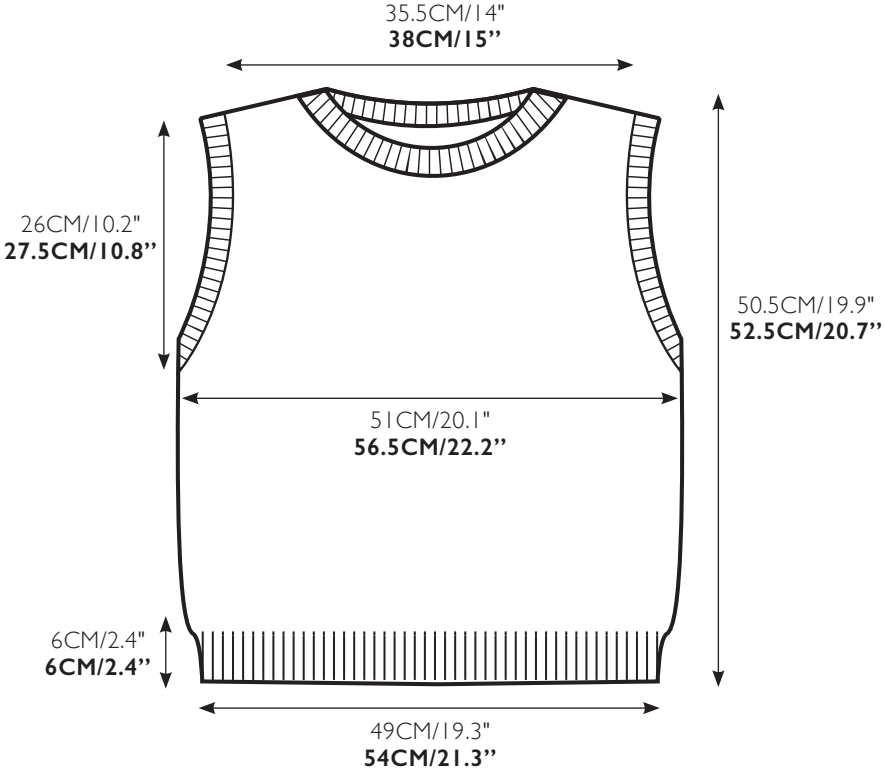

KNIT CODE

More complex knitting patterns can be a little longer than simpler ones, which is why abbreviations are used. Don't worry if you've never used them before - you'll quickly get the hang of them. And once you speak Knit Code, you know you're a real Knitter! Here are the abbreviations used in this pattern:

ST(S)	Stitch(es)
K	Knit
P	Purl
SSK	Left-leaning decrease
K2TOG	Right-leaning decrease
P2TOG	Left-leaning purl decrease
P2TOGTBL	Right-leaning purl decrease
C4B	Slip the next 2 stitches onto your cable needle and behind your work. Knit the next 2 stitches on your left-hand needle, then knit the 2 stitches on your cable needle.
C3B	Slip the next stitch onto your cable needle and behind your work. Knit the next 2 stitches on your left-hand needle, then knit the stitch on your cable needle.

C2B	Slip the next stitch onto your cable needle and behind your work. Knit the next stitch on your left-hand needle, then knit the stitch on your cable needle.
Dec	Decrease
Inc	Increase
C row:	Cable row:
Dec/ c row:	Decrease and cable row:
Rep	Repeat
Rep once [twice] more	Repeat the section inside the stars (★) once [twice] more
Rep until x st(s) left	Repeat the section inside the stars (★) until you have x stitch(es) left of your row

EMMA TANK

LET'S BEGIN

LET'S GET MAKING

TOOL KIT:

- 1 ball of WATG's Shiny Happy Cotton in colour A
- 5 [5:6:7] balls of WATG's Shiny Happy Cotton in colour B
- 1 Emma Tank pattern
- 1 set of 3.5mm (US4) 100cm/40" circular knitting needles
- 1 set of 5mm (US8) 100cm/40" circular knitting needles
- 1 5mm (US8) cable needle
- 1 sewing needle

TENSION:

To ensure your knitting has the same measurements as the pattern, it is a good idea to make a tension swatch before you start knitting your project. A tension swatch is a small sample of your knitting where you count the stitches and rows and check them against the measurements (cm/in) given in the pattern. If you get MORE stitches/rows than the pattern's tension, it means your knitting is **tighter**. If you get FEWER stitches/rows than the pattern, your knitting is **looser**. Sometimes, it works to knit tighter or looser to compensate.

3.5MM (US4) 1X1 RIB STITCH

10 cm/4" = 28 stitches

10 cm/4" = 28 rows

5MM (US8) REVERSE STOCKING STITCH

10 cm/4" = 18 stitches

10 cm/4" = 24 rows

5MM (US8) CABLE REPEAT

3.5cm/1.4" = 10 stitches

10 cm/4" = 22 rows

You can find all techniques on page 28

Pssst! Remember that you must not copy our patterns and sell, or even give them away for free, in accordance with copyright law.

HOW TO MAKE YOUR EMMA TANK

Your tank is made up of two pieces, a front piece and a back piece. You will knit your two pieces separately and then sew the shoulder seams together and knit your neck trim and then armhole trims before sewing your side seams.

For this pattern you will be working flat, using circular needles.

BACK

- 1 Using colour A and 3.5mm (US4) circular needles cast on 115 [125:139:153] sts using the long-tail cast on technique.

- 2 Starting with a wrong side row, work 1 row in 1x1 rib. Cut colour A.

- 3 Using colour B and starting with a right side row, work in 1x1 rib until your piece measures 6cm/2.4" from the cast on edge (approx. a further 16 rows). Your last row must be a wrong side row.

- 4 **(RS) Inc row:** Using 5mm (US8) circular needles, p 5 [5:6:7] sts, k4 sts, p2 sts, ★k2 sts, p2 sts, k4 sts, p2 sts★. Rep the section inside the stars (★) a further 0 [1:2:3] time(s). ▲K1 st, inc 1 st, p2 sts, k4 sts, p2 sts.▲ Rep the section inside the triangles (▲) a further 8 [8:6:4] times. Rep the section inside the stars (★) a further 1 [1:3:5] time(s), p 3 [3:4:5] sts. (124 [134:146:158] sts.)

- 5 K 3 [3:4:5] sts, ★k2 sts, p4 sts, k2 sts, p2 sts★. Rep until 11 [11:12:13] sts left, k2 sts, p4 sts, k 5 [5:6:7] sts.

- 6 P 5 [5:6:7] sts, k4 sts, p2 sts, ★k2 sts, p2 sts, k4 sts, p2 sts★. Rep until 3 [3:4:5] sts left, p 3 [3:4:5] sts.

- 7 Rep step 5 once more.

- 8 **C row:** P 5 [5:6:7] sts, C4B, p2 sts, ★k2 sts, p2 sts, C4B, p2 sts★. Rep until 3 [3:4:5] sts left, p 3 [3:4:5] sts.

- 9 K 3 [3:4:5] sts, ★k2 sts, p4 sts, k2 sts, p2 sts★. Rep until 11 [11:12:13] sts left, k2 sts, p4 sts, k 5 [5:6:7] sts.

- 10 P 5 [5:6:7] sts, k4 sts, p2 sts, ★k2 sts, p2 sts, k4 sts, p2 sts★. Rep until 3 [3:4:5] sts left, p 3 [3:4:5] sts.

- 11 Rep steps 9 and 10 once more.

- 12 Rep step 9 once more.

- 13 Rep steps 8 to 12 a further 5 times.

- 14 Rep steps 8 and 9 once more.

- 15 **Dec row:** Cast off 4 [4:5:6] sts p-wise, with 1 st already on your right-hand needle, k4 sts, p2 sts, ★k2 sts, p2 sts, k4 sts, p2 sts★. Rep until 3 [3:4:5] sts left, p 3 [3:4:5] sts. (120 [130:141:152] sts.)

- 16 Dec row:** Cast off 4 [4:5:6] sts, with 1 st already on your right-hand needle, p4 sts, k2 sts, p2 sts, ★k2 sts, p4 sts, k2 sts, p2 sts★. Rep until 7 sts left, k2 sts, p4 sts, k1 st. (116 [126:136:146] sts.)
-
- 17 Dec row:** P2tog, p5 sts, ★k2 sts, p2 sts, k4 sts, p2 sts★. Rep until 9 sts left, k2 sts, p5 sts, p2tog tbl. (114 [124:134:144] sts.)
-
- 18** K6 sts, p2 sts, ★k2 sts, p4 sts, k2 sts, p2 sts★. Rep until 6 sts left, k6 sts.
-
- 19 Dec / C row:** P2tog, p4 sts, ★k2 sts, p2 sts, C4B, p2 sts★. Rep until 8 sts left, k2 sts, p4 sts, p2tog tbl. (112 [122:132:142] sts.)
-
- 20** K5 sts, p2 sts, ★k2 sts, p4 sts, k2 sts, p2 sts★. Rep until 5 sts left, k5 sts.
-
- 21 Dec row:** P2tog, p3 sts, ★k2 sts, p2 sts, k4 sts, p2 sts★. Rep until 7 sts left, k2 sts, p3 sts, p2tog tbl. (110 [120:130:140] sts.)
-
- 22** K4 sts, p2 sts, ★k2 sts, p4 sts, k2 sts, p2 sts★. Rep until 4 sts left, k4 sts.
-
- 23 Dec row:** P2tog, p2 sts, ★k2 sts, p2 sts, k4 sts, p2 sts★. Rep until 6 sts left, k2 sts, p2 sts, p2tog tbl. (108 [118:128:138] sts.)
-
- 24** K3 sts, p2 sts, ★k2 sts, p4 sts, k2 sts, p2 sts★. Rep until 3 sts left, k3 sts.
-
- 25 Dec / C row:** P2tog, p1 st, ★k2 sts, p2 sts, C4B, p2 sts★. Rep until 5 sts left, k2 sts, p1 st, p2tog tbl. (106 [116:126:136] sts.)
-
- 26** K2 sts, p2 sts, ★k2 sts, p4 sts, k2 sts, p2 sts★. Rep until 2 sts left, k 2 sts.
-
- 27 Dec row:** P2tog, ★k2 sts, p2 sts, k4 sts, p2 sts★. Rep until 4 sts left, k2 sts, p2tog tbl. (104 [114:124:134] sts.)
-
- 28** K1 st, p2 sts, ★k2 sts, p4 sts, k2 sts, p2 sts★. Rep until 1 st left, k1 st.
-
- 29 Dec row:** P2tog, p3 sts, k4 sts, p2 sts, ★k2 sts, p2 sts, k4 sts, p2 sts★. Rep until 3 sts left, p1 st, p2tog tbl. (102 [112:122:132] sts.)
-
- 30** K2 sts, ★k2 sts, p4 sts, k2 sts, p2 sts★. Rep until 10 sts left, k2 sts, p4 sts, k4 sts.
-
- 31 Dec / C row:** P2tog, p2 sts, C4B, p2 sts, ★k2 sts, p2 sts, C4B, p2 sts★. Rep until 2 sts left, p2tog tbl. (100 [110:120:130] sts.)
-
- 32** K1 st, ★k2 sts, p4 sts, k2 sts, p2 sts★. Rep until 9 sts left, k2 sts, p4 sts, k3 sts.
-
- 33 Dec row:** P2tog, p1 st, k4 sts, p2 sts, ★k2 sts, p2 sts, k4 sts, p2 sts★. Rep until 11 sts left, k2 sts, p2 sts, k4 sts, p1 st, p2tog tbl. (98 [108:118:128] sts.)
-
- 34** ★K2 sts, p4 sts, k2 sts, p2 sts★. Rep until 8 sts left, k2 sts, p4 sts, k2 sts.
-
- 35 Dec row:** P2tog, p6 sts, ★k2 sts, p2 sts, k4 sts, p2 sts★. Rep until 10 sts left, k2 sts, p6 sts, p2tog tbl. (96 [106:116:126] sts.)

36 K7 sts, p2 sts, ★k2 sts, p4 sts, k2 sts, p2 sts★. Rep until 7 sts left, k7 sts.

37 Dec / C row: P2tog, p5 sts, ★k2 sts, p2 sts, C4B, p2 sts★. Rep until 9 sts left, k2 sts, p5 sts, p2tog tbl. (94 [104:114:124] sts.)

38 K6 sts, p2 sts, ★k2 sts, p4 sts, k2 sts, p2 sts★. Rep until 6 sts left, k6 sts.

39 Dec row: P2tog, p4 sts, ★k2 sts, p2 sts, k4 sts, p2 sts★. Rep until 8 sts left, k2 sts, p4 sts, p2tog tbl. (92 [102:112:122] sts.)

SIZES 2, 3 AND 4 ONLY:

40 K5 sts, p2 sts, ★k2 sts, p4 sts, k2 sts, p2 sts★. Rep until 5 sts left, k5 sts.

41 Dec row: P2tog, p3 sts, ★k2 sts, p2 sts, k4 sts, p2 sts★. Rep until 7 sts left, k2 sts, p3 sts, p2tog tbl. ([100:110:120] sts.)

42 K4 sts, p2 sts, ★k2 sts, p4 sts, k2 sts, p2 sts★. Rep until 4 sts left, k4 sts.

43 Dec / C row: P2tog, p2 sts, ★k2 sts, p2 sts, C4B, p2 sts★. Rep until 6 sts left, k2 sts, p2 sts, p2tog tbl. ([98:108:118] sts.)

44 K3 sts, p2 sts, ★k2 sts, p4 sts, k2 sts, p2 sts★. Rep until 3 sts left, k3 sts.

45 Dec row: P2tog, p1 st, ★k2 sts, p2 sts, k4 sts, p2 sts★. Rep until 5 sts left, k2 sts, p1 st, p2tog tbl. ([96:106:116] sts.)

SIZES 3 AND 4 ONLY:

46 K2 sts, p2 sts, ★k2 sts, p4 sts, k2 sts, p2 sts★. Rep until 2 sts left, k2 sts.

47 Dec row: P2tog, ★k2 sts, p2 sts, k4 sts, p2 sts★. Rep until 4 sts left, k2 sts, p2tog tbl. ([104:114] sts.)

SIZE 4 ONLY:

48 K1 st, p2 sts, ★k2 sts, p4 sts, k2 sts, p2 sts★. Rep until 1 st left, k1 st.

49 Dec / C row: Ssk, k1 st, p2 sts, C4B, p2 sts, ★k2 sts, p2 sts, C4B, p2 sts★. Rep until 3 sts left, k1 st, k2tog. (112 sts.)

SIZES 1, 2 AND 4 ONLY:

50 K 5 [2:0] sts, p2 sts, ★k2 sts, p4 sts, k2 sts, p2 sts★. Rep until 5 [2:0] sts left, k 5 [2:0] sts.

51 P 5 [2:0] sts, ★k2 sts, p2 sts, k4 sts, p2 sts★. Rep until 7 [4:2] sts left, k2 sts, p 5 [2:0] sts.

SIZE 4 ONLY:

52 Rep steps 50 and 51 once more.

ALL SIZES:

53 K 5 [2:1:0] st(s), p2 sts, ★k2 sts, p4 sts, k2 sts, p2 sts★. Rep until 5 [2:1:0] st(s) left, k 5 [2:1:0] st(s).

54 C row: P 5 [2:1:0] st(s), ★k2 sts, p2 sts, C4B, p2 sts★. Rep until 7 [4:3:2] sts left, k2 sts, p 5 [2:1:0] st(s).

55 K 5 [2:1:0] st(s), p2 sts, ★k2 sts, p4 sts, k2 sts, p2 sts★. Rep until 5 [2:1:0] st(s) left, k 5 [2:1:0] st(s).

56 P 5 [2:1:0] st(s), ★k2 sts, p2 sts, k4 sts, p2 sts★. Rep until 7 [4:3:2] sts left, k2 sts, p 5 [2:1:0] st(s).

57 K 5 [2:1:0] st(s), p2 sts, ★k2 sts, p4 sts, k2 sts, p2 sts★. Rep until 5 [2:1:0] st(s) left, k 5 [2:1:0] st(s).

58 P 5 [2:1:0] st(s), ★k2 sts, p2 sts, k4 sts, p2 sts★. Rep until 7 [4:3:2] sts left, k2 sts, p 5 [2:1:0] st(s).

59 Rep step 57 once more.

60 Rep steps 54 to 59 twice [once:once:once] more.

SIZES 2, 3 AND 4 ONLY:

61 Rep steps 54 to [55:57:55] once more.

You will now shape your back neckline.

SIZE 1 ONLY:

62 **Dec / C row:** P5 sts, k2 sts, p2 sts, C4B, p2 sts, k2 sts, p2 sts, C3B, Cast off 48 sts, using the st already on your needle C3B, p2 sts, k2 sts, p2 sts, C4B, p2 sts, k2 sts, p5 sts.

From now on you will only be working across half of your sts to shape the back neckline. You'll come back to the other sts later. (22 sts in each half.)

63 K5 sts, p2 sts, k2 sts, p4 sts, k2 sts, p2 sts, k2 sts, p3 sts.

64 **Dec row:** Ssk, k1 st, p2 sts, k2 sts, p2 sts, k4 sts, p2 sts, k2 sts, p5 sts. (21 sts.)

65 K5 sts, p2 sts, k2 sts, p4 sts, k2 sts, p2 sts, k2 sts, p2 sts.

66 **Dec row:** Ssk, p2 sts, k2 sts, p2 sts, k4 sts, p2 sts, k2 sts, p5 sts. (20 sts.)

67 K5 sts, p2 sts, k2 sts, p4 sts, k2 sts, p2 sts, k3 sts.

SIZE 2 ONLY:

68 **Dec row:** ★P2 sts, k2 sts, p2 sts, k4 sts★, rep once more, p1 st. Cast off 54 sts, with 1 st already on your right-hand needle, k4 sts, rep the section inside the stars once more, p2 sts, k2 sts, p2 sts.

From now on you will only be working across half of your sts to shape the back neckline. You'll come back to the other sts later. (21 sts in each half.)

69 ★K2 sts, p2 sts, k2 sts, p4 sts.★ Rep once more, k1 st.

70 **Dec row:** Ssk, k3 sts, p2 sts, k2 sts, p2 sts, k4 sts, p2 sts, k2 sts, p2 sts. (20 sts.)

71 ★K2 sts, p2 sts, k2 sts, p4 sts.★ Rep once more.

72 **Dec / C row:** Ssk, k2 sts, p2 sts, k2 sts, p2 sts, C4B, p2 sts, k2 sts, p2 sts. (19 sts.)

73 K2 sts, p2 sts, k2 sts, p4 sts, k2 sts, p2 sts, k2 sts, p3 sts.

SIZES 3 AND 4 ONLY:

74 Dec row: P [1:0] st(s), ★k2 sts, p2 sts, k4 sts, p2 sts★. Rep once more, k2 sts, p2 sts, k [0:4] sts. Cast off [54:56] sts, with 1 st already on your right-hand needle, p [1:0] st(s), k [0:3] sts, p [0:2] sts, rep the section inside the stars twice more, k2 sts, p [1:0] st(s).

From now on you will only be working across half of your sts to shape the back neckline. You'll come back to the other sts later. ([25:28] sts in each half.)

SIZE 3 ONLY:

75 K1 st, ★p2 sts, k2 sts, p4 sts, k2 sts★. Rep once more, p2 sts, k2 sts.

76 Dec / C row: Ssk, k2 st, ★p2 sts, C4B, p2 sts, k2 sts★. Rep once more, p1 st. (24 sts.)

77 K1 st, ★p2 sts, k2 sts, p4 sts, k2 sts★. Rep once more, p2 sts, k1 st.

78 Dec row: Ssk, k1 st, ★p2 sts, C4B, p2 sts, k2 sts★. Rep once more, p1 st. (23 sts.)

79 K1 st, ★p2 sts, k2 sts, p4 sts, k2 sts★. Rep once more, k2 sts.

SIZE 4 ONLY:

80 ★P2 sts, k2 sts, p4 sts, k2 sts★ Rep once more, p2 sts, k2 sts, p4 sts.

81 Dec row: Ssk, k2 sts, p2 sts, k2 sts, ★p2 sts, k4 sts, p2 sts, k2 sts★. Rep once more. (27 sts.)

82 ★P2 sts, k2 sts, p4 sts, k2 sts★ Rep once more, p2 sts, k2 sts, p3 sts.

83 Dec / C row: Ssk, k1 st, p2 sts, k2 sts, ★p2 sts, C4B, p2 sts, k2 sts★. Rep once more. (26 sts.)

84 ★P2 sts, k2 sts, p4 sts, k2 sts★ Rep once more, p2 sts, k2 sts, p2 sts.

ALL SIZES:

85 Cast off.

One side of your back neck is now complete, With the wrong side of the fabric facing you, re-join the yarn to the sts that have been waiting on the needle, as if adding in a new ball of yarn.

SIZE 1 ONLY:

86 P3 sts, k2 sts, p2 sts, k2 sts, p4 sts, k2 sts, p2 sts, k5 sts.

87 Dec row: P5 sts, k2 sts, p2 sts, k4 sts, p2 sts, k2 sts, p2 sts, k1 st, k2tog. (21 sts.)

88 P2 sts, k2 sts, p2 sts, k2 sts, p4 sts, k2 sts, p2 sts, k5 sts.

89 Dec row: P5 sts, k2 sts, p2 sts, k4 sts, p2 sts, k2 sts, p2 sts, k2tog. (20 sts.)

90 K3 sts, p2 sts, k2 sts, p4 sts, k2 sts, p2 sts, k5 sts.

SIZE 2 ONLY:

91 K1 sts, p4 sts, k2 sts, p2 sts, k2 sts, p4 sts, k2 sts, p2 sts, k2 sts.

92 Dec row: P2 sts, k2 sts, p2 sts, k4 sts, p2 sts, k2 sts, p2 sts, k3 sts, k2tog. (20 sts.)

93 P4 sts, k2 sts, p2 sts, k2 sts, p4 sts, k2 sts, p2 sts, k2 sts.

94 Dec / C row: P2 sts, k2 sts, p2 sts, C4B, p2 sts, k2 sts, p2 sts, k2 sts, k2tog. (19 sts.)

95 P3 sts, k2 sts, p2 sts, k2 sts, p4 sts, k2 sts, p2 sts, k2 sts.

SIZE 3 ONLY:

96 K2 sts, ★p2 sts, k2 sts, p4 sts, k2 sts★. Rep once more, p2 sts, k1 st.

97 Dec / C row: P1 st, ★k2 sts, p2 sts, C4B, p2 sts★. Rep once more, k2 sts, p2tog tbl. (24 sts.)

98 K1 st, ★p2 sts, k2 sts, p4 sts, k2 sts★. Rep once more, p2 sts, k1 st.

99 Dec row: P1 st, ★k2 sts, p2 sts, k4 sts, p2 sts★. Rep once more, k1 st, k2tog. (23 sts.)

100 ★P2 sts, k2 sts, p4 sts, k2 sts★. Rep once more, p2 sts, k1 st.

SIZE 4 ONLY:

101 P4 sts, ★k2 sts, p2 sts, k2 sts, p4 sts★. Rep once more, k2 sts, p2 sts.

102 Dec row: K2 sts, ★p2 sts, k4 sts, p2 sts, k2 sts★. Rep once more, p2 sts, k2 sts, k2tog. (27 sts.)

103 P3 sts, ★k2 sts, p2 sts, k2 sts, p4 sts★. Rep once more, k2 sts, p2 sts.

104 Dec / C row: K2 sts, ★p2 sts, C4B, p2 sts, k2 sts★. Rep once more, p2 sts, k1 st, k2tog. (26 sts.)

105 P2 sts, ★k2 sts, p2 sts, k2 sts, p4 sts★. Rep once more, k2 sts, p2 sts.

ALL SIZES:

106 Cast off.

FRONT

1 Repeat steps 1 to 56 [45:47:49] as the back.

2 K5 [2:1:0] st(s), p2 sts, ★k2 sts, p4 sts, k2 sts, p2 sts★. Rep until 5 [2:1:0] st(s) left, k 5 [2:1:0] st(s).

You will now shape your front neckline.

SIZES 1, 2 AND 4 ONLY:

3 Dec row: P 5 [2:0] sts, ★k2 sts, p2 sts, k4 sts, p2 sts★. Rep a further 1 [1:2] time(s), k2 sts, p 1 [2:2] st(s), k 0 [1:1] st(s), cast off 36 [42:42] sts. With 1 st already on your right-hand needle, p 0 [2:2] sts. Rep the section inside the stars a further 2 [2:3] times, k2 sts, p 5 [2:0] sts.

From now on you will only be working across half of your sts to shape the front neckline. You'll come back to the other sts later. (28 [27:35] sts in each half.)

SIZE 3 ONLY:

- 4 Dec / C row:** P1 st, ★k2 sts, p2 sts, C4B, p2 sts★. Rep twice more, cast off 42 sts. With 1 st already on your right-hand needle, p1 st, C4B, p2 sts, Rep the section inside the stars twice more, k2 sts, p1 st.

From now on you will only be working across half of your sts to shape the front neckline. You'll come back to the other sts later. (31 sts in each half.)

SIZE 1 ONLY:

- 5** K5 sts, p2 sts, ★k2 sts, p4 sts, k2 sts, p2 sts★. Rep once more, k1 st.
- 6 Dec / C row:** P2tog, p3 sts, ★C4B, p2 sts, k2 sts, p2 sts★. Rep once more, p3 sts. (27 sts.)
- 7** K5 sts, p2 sts, k2 sts, p4 sts, k2 sts, p2 sts, k2 sts, p4 sts, k4 sts.
- 8 Dec row:** P2tog, p2 sts, ★k4 sts, p2 sts, k2 sts, p2 sts★. Rep once more, p3 sts. (26 sts.)
- 9** K5 sts, ★p2 sts, k2 sts, p4 sts, k2 sts★. Rep once more, p1 st.
- 10 Dec row:** P2tog, p1 st, ★k4 sts, p2 sts, k2 sts, p2 sts★. Rep once more, p3 sts. (25 sts.)
- 11** K5 sts, ★p2 sts, k2 sts, p4 sts, k2 sts★. Rep once more.
- 12 Dec / C row:** P2tog, ★C4B, p2 sts, k2 sts, p2 sts★. Rep once more, p3 sts. (24 sts.)

- 13** K5 sts, p2 sts, k2 sts, p4 sts, k2 sts, p2 sts, k2 sts, p4 sts, k1 st.
- 14 Dec row:** Ssk, k3 sts, p2 sts, k2 sts, p2 sts, k4 sts, p2 sts, k2 sts, p5 sts. (23 sts.)
- 15** K5 sts, p2 sts, k2 sts, p4 sts, k2 sts, p2 sts, k2 sts, p4 sts.
- 16 Dec row:** Ssk, k2 sts, p2 sts, k2 sts, p2 sts, k4 sts, p2 sts, k2 sts, p5 sts. (22 sts.)
- 17** K5 sts, p2 sts, k2 sts, p4 sts, k2 sts, p2 sts, k2 sts, p3 sts.
- 18 Dec / C row:** Ssk, k1 st, p2 sts, k2 sts, p2 sts, C4B, p2 sts, k2 sts, p5 sts. (21 sts.)
- 19** K5 sts, p2 sts, k2 sts, p4 sts, k2 sts, p2 sts, k2 sts, p2 sts.
- 20 Dec row:** P2tog, p2 sts, k2 sts, p2 sts, k4 sts, p2 sts, k2 sts, p5 sts. (20 sts.)
- 21** K5 sts, p2 sts, k2 sts, p4 sts, k2 sts, p2 sts, k3 sts.
- 22** P3 sts, k2 sts, p2 sts, k4 sts, p2 sts, k2 sts, p5 sts.
- 23** Rep step 21 once more.
- SIZE 2 ONLY:**
- 24** K2 sts, p2 sts, ★k2 sts, p4 sts, k2 sts, p2 sts★. Rep once more, k3 sts.
- 25 Dec / C row:** P2tog, p1 st, ★k2 sts, p2 sts, C4B, p2 sts★. Rep once more, k2 sts, p2 sts. (26 sts.)

- 26 K2 sts, p2 sts, ★k2 sts, p4 sts, k2 sts, p2 sts★. Rep once more, k2 sts.
-
- 27 **Dec row:** P2tog, ★k2 sts, p2 sts, k4 sts, p2 sts★. Rep once more, k2 sts, p2 sts. (25 sts.)
-
- 28 K2 sts, p2 sts, ★k2 sts, p4 sts, k2 sts, p2 sts★. Rep once more, p1 st.
-
- 29 **Dec row:** P2tog, p3 sts, ★k4 sts, p2 sts, k2 sts, p2 sts★. Rep once more. (24 sts.)
-
- 30 K2 sts, ★p2 sts, k2 sts, p4 sts, k2 sts★. Rep once more, k2 sts.
-
- 31 **Dec / C row:** P2tog, p2 sts, ★C4B, p2 sts, k2 sts, p2 sts★. Rep once more. (23 sts.)
-
- 32 K2 sts, ★p2 sts, k2 sts, p4 sts, k2 sts★. Rep once more, k1 st.
-
- 33 **Dec row:** P2tog, p1 st, ★k4 sts, p2 sts, k2 sts, p2 sts★. Rep once more. (22 sts.)
-
- 34 K2 sts, ★p2 sts, k2 sts, p4 sts, k2 sts★. Rep once more.
-
- 35 **Dec row:** P2tog, ★k4 sts, p2 sts, k2 sts, p2 sts★. Rep once more. (21 sts.)
-
- 36 ★K2 sts, p2 sts, k2 sts, p4 sts.★ Rep once more, k1 st.
-
- 37 **Dec / C row:** Ssk, C3B, p2 sts, k2 sts, p2 sts, C4B, purl 2 stitches, k2 sts, p2 sts. (20 sts.)
-
- 38 ★K2 sts, p2 sts, k2 sts, p4 sts.★ Rep once more.
-
- 39 **Dec row:** Ssk, k2 sts, p2 sts, k2 sts, p2 sts, k4 sts, p2 sts, k2 sts, p2 sts. (19 sts.)
-
- 40 K2 sts, p2 sts, k2 sts, p4 sts, k2 sts, p2 sts, k2 sts, p3 sts.
-
- 41 K3 sts, p2 sts, k2 sts, p2 sts, k4 sts, p2 sts, k2 sts, p2 sts.
-
- 42 Rep step 40 once more.
-
- 43 **C row:** K3 sts, p2 sts, k2 sts, p2 sts, C4B, p2 sts, k2 sts, p2 sts.
-
- 44 Rep step 40 once more.
-
- SIZE 3 ONLY:**
- 45 K1 st, ★p2 sts, k2 sts, p4 sts, k2 sts★. Rep once more, p2 sts, k2 sts, p4 sts, k2 sts.
-
- 46 **Dec row:** P2tog, k4 sts, ★p2 sts, k2 sts, p2 sts, k4 sts★. Rep once more, p2 sts, k2 sts, p1 st. (30 sts.)
-
- 47 K1 st, ★p2 sts, k2 sts, p4 sts, k2 sts★. Rep once more, p2 sts, k2 sts, p4 sts, k1 st.
-
- 48 **Dec row:** Ssk, k3 sts, ★p2 sts, k2 sts, p2 sts, k4 sts★. Rep once more, p2 sts, k2 sts, p1 st. (29 sts.)
-
- 49 K1 st, ★p2 sts, k2 sts, p4 sts, k2 sts★. Rep once more, p2 sts, k2 sts, p4 sts.
-
- 50 **Dec / C row:** Ssk, C2B, ★p2 sts, k2 sts, p2 sts, C4B★. Rep once more, p2 sts, k2 sts, p1 st. (28 sts.)
-
- 51 K1 st, ★p2 sts, k2 sts, p4 sts, k2 sts★. Rep once more, p2 sts, k2 sts, p3 sts.

52 Dec row: Ssk, k1 st, ★p2 sts, k2 sts, p2 sts, k4 sts★. Rep once more, p2 sts, k2 sts, p1 st. (27 sts.)

53 K1 st, ★p2 sts, k2 sts, p4 sts, k2 sts★. Rep once more, p2 sts, k2 sts, p2 sts.

54 Dec row: P2tog, ★p2 sts, k2 sts, p2 sts, k4 sts★. Rep once more, p2 sts, k2 sts, p1 st. (26 sts.)

55 K1 st, ★p2 sts, k2 sts, p4 sts, k2 sts★. Rep once more, p2 sts, k3 sts.

56 Dec / C row: P2tog, p1 st, ★k2 sts, p2 sts, C4B, p2 sts★. Rep once more, k2 sts, p1 st. (25 sts.)

57 K1 st, ★p2 sts, k2 sts, p4 sts, k2 sts★. Rep once more, p2 sts, k2 sts.

58 Dec row: Ssk, ★k2 sts, p2 sts, k4 sts, p2 sts★. Rep once more, k2 sts, p1 st. (24 sts.)

59 K1 st, ★p2 sts, k2 sts, p4 sts, k2 sts★. Rep once more, p2 sts, k1 st.

60 Dec row: Ssk, k1 st, ★p2 sts, k4 sts, p2 sts, k2 sts★. Rep once more, p1 st. (23 sts.)

61 K1 st, ★p2 sts, k2 sts, p4 sts, k2 sts★. Rep once more, k2 sts.

62 C row: P4 sts, C4B, p2 sts, k2 sts, p2 sts, C4B, p2 sts, k2 sts, p1 st.

63 Rep step 61 once more.

64 P4 sts, k4 sts, p2 sts, k2 sts, p2 sts, k4 sts, p2 sts, k2 sts, p1 st.

65 Rep step 61 once more.

SIZE 4 ONLY:

66 ★P2 sts, k2 sts, p4 sts, k2 sts★. Rep twice more, p2 sts, k2 sts, p1 st.

67 Dec row: P2tog, p1 st, ★k2 sts, p2 sts, k4 sts, p2 sts★. Rep twice more, k2 sts. (34 sts.)

68 ★P2 sts, k2 sts, p4 sts, k2 sts★. Rep twice more, p2 sts, k2 sts.

69 Dec / C row: P2tog, ★k2 sts, p2 sts, C4B, p2 sts★. Rep twice more, k2 sts. (33 sts.)

70 ★P2 sts, k2 sts, p4 sts, k2 sts★. Rep twice more, p2 sts, k1 st.

71 Dec row: Ssk, k1 st, ★p2 sts, k4 sts, p2 sts, k2 sts★. Rep twice more. (32 sts.)

72 ★P2 sts, k2 sts, p4 sts, k2 sts★. Rep twice more, p2 sts.

73 Dec row: Ssk, ★p2 sts, k4 sts, p2 sts, k2 sts★. Rep twice more. (31 sts.)

74 ★P2 sts, k2 sts, p4 sts, k2 sts★. Rep twice more, p1 st.

75 Dec / C row: P2tog, p1 st, C4B, p2 sts, k2sts, ★p2 sts, C4B, p2 sts, k2 sts★. Rep once more. (30 sts.)

76 ★P2 sts, k2 sts, p4 sts, k2 sts★. Rep twice more.

77 Dec row: P2tog, k4 sts, p2 sts, k2sts, ★p2 sts, k4 sts, p2 sts, k2 sts★. Rep

once more. (29 sts.)

78 ★P2 sts, k2 sts, p4 sts, k2 sts★. Rep once more, p2 sts, k2 sts, p4 sts, k1 st.

79 **Dec row:** Ssk, k3 sts, p2 sts, k2sts, ★p2 sts, k4 sts, p2 sts, k2 sts★. Rep once more. (28 sts.)

80 ★P2 sts, k2 sts, p4 sts, k2 sts.★ Rep once more, p2 sts, k2 sts, p4 sts.

81 **Dec / C row:** Ssk, C2B, p2 sts, k2 sts, ★p2 sts, C4B, p2 sts, k2 sts★. Rep once more. (27 sts.)

82 ★P2 sts, k2 sts, p4 sts, k2 sts.★ Rep once more, p2 sts, k2 sts, p3 sts.

83 **Dec row:** Ssk, k1 st, p2 sts, k2 sts, ★p2 sts, k4 sts, p2 sts, k2 sts★. Rep once more. (26 sts.)

84 ★P2 sts, k2 sts, p4 sts, k2 sts.★ Rep once more, p2 sts, k2 sts, p2 sts.

85 K2 sts, p2 sts, k2 sts, ★p2 sts, k4 sts, p2 sts, k2 sts★. Rep once more.

86 Rep step 84 once more.

87 **C row:** K2 sts, p2 sts, k2 sts, ★p2 sts, C4B, p2 sts, k2 sts★. Rep once more.

88 Rep step 84 once more.

ALL SIZES:

89 Cast off.

One side of your front neck is now complete, With the wrong side of the

fabric facing you, re-join the yarn to the sts that have been waiting on the needle, as if adding in a new ball of yarn.

SIZE 1 ONLY:

90 K1 st, ★p2 sts, k2sts, p4 sts, k2 sts★. Rep once more, p2 sts, k5 sts.

91 **Dec / C row:** P5 sts, ★k2 sts, p2 sts, C4B, p2 sts★. Rep once more, p1 sts, p2tog tbl. (27 sts.)

92 K4 sts, p4 sts, k2 sts, p2 sts, k2 sts, p4 sts, k2 sts, p2 sts, k5 sts.

93 **Dec row:** P5 sts, k2 sts, p2 sts, k4 sts, p2 sts, k2 sts, p2 sts, k4 sts, p2 sts, p2tog tbl. (26 sts.)

94 K3 sts, p4 sts, k2 sts, p2 sts, k2 sts, p4 sts, k2 sts, p2 sts, k5 sts.

95 **Dec row:** P5 sts, k2 sts, p2 sts, k4 sts, p2 sts, k2 sts, p2 sts, k4 sts, p1 st, p2tog tbl. (25 sts.)

96 K2 sts, p4 sts, k2 sts, p2 sts, k2 sts, p4 sts, k2 sts, p2 sts, k5 sts.

97 **Dec / C row:** P5 sts, k2 sts, p2 sts, C4B, p2 sts, k2 sts, p2 sts, C4B, p2tog tbl. (24 sts.)

98 K1 st, p4 sts, k2 sts, p2 sts, k2 sts, p4 sts, k2 sts, p2 sts, k5 sts.

99 **Dec row:** P5 sts, k2 sts, p2 sts, k4 sts, p2 sts, k2 sts, p2 sts, k3 sts, p2tog tbl. (23 sts.)

100 P4 sts, k2 sts, p2 sts, k2 sts, p4 sts, k2 sts, p2 sts, k5 sts.

101 Dec row: P5 sts, k2 sts, p2 sts, k4 sts, p2 sts, k2 sts, p2 sts, k2 tog. (22 sts.)

102 P3 sts, k2 sts, p2 sts, k2 sts, p4 sts, k2 sts, p2 sts, k5 sts.

103 Dec / C row: P5 sts, k2 sts, p2 sts, C4B, p2 sts, k2 sts, p2 sts, k1 st, k2tog. (21 sts.)

104 P2 sts, k2 sts, p2 sts, k2 sts, p4 sts, k2 sts, p2 sts, k5 sts.

105 Dec row: P5 sts, k2 sts, p2 sts, k4 sts, p2 sts, k2 sts, p2 sts, p2tog tbl. (20 sts.)

106 K3 sts, p2 sts, k2 sts, p4 sts, k2 sts, p2 sts, k5 sts.

107 P5 sts, k2 sts, p2 sts, k4 sts, p2 sts, k2 sts, p3 sts.

108 Rep step 106 once more.

SIZE 2 ONLY:

109 K3 sts, p2 sts, ★k2 sts, p4 sts, k2 sts, p2 sts★. Rep once more, k2 sts.

110 Dec / C row: P2 sts, ★k2 sts, p2 sts, C4B, p2 sts★. Rep once more, k2 sts, p1 st, p2tog tbl. (26 sts.)

111 K2 sts, p2 sts, ★k2 sts, p4 sts, k2 sts, p2 sts★. Rep once more, k2 sts.

112 Dec row: P2 sts, ★k2 sts, p2 sts, k4

sts, p2 sts★. Rep once more, k2 sts, p2tog tbl. (25 sts.)

113 K1 st, p2 sts, ★k2 sts, p4 sts, k2 sts, p2 sts★. Rep once more, k2 sts.

114 Dec row: P2 sts, ★k2 sts, p2 sts, k4 sts, p2 sts★. Rep once more, p1 st, p2tog tbl. (24 sts.)

115 K4 sts, ★p4 sts, k2 sts, p2 sts, k2 sts★. Rep once more.

116 Dec / C row: P2 sts, ★k2 sts, p2 sts, C4B, p2 sts★. Rep once more, p2tog tbl. (23 sts.)

117 K3 sts, ★p4 sts, k2 sts, p2 sts, k2 sts★. Rep once more.

118 Dec row: ★P2 sts, k2 sts, p2 sts, k4 sts★. Rep once more, p1 st, p2tog tbl. (22 sts.)

119 K2 sts, ★p4 sts, k2 sts, p2 sts, k2 sts★. Rep once more.

120 Dec row: ★P2 sts, k2 sts, p2 sts, k4 sts★. Rep once more, p2tog tbl. (21 sts.)

121 K1 st, ★p4 sts, k2 sts, p2 sts, k2 sts★. Rep once more.

122 Dec / C row: P2 sts, k2 sts, p2 sts, C4B, p2 sts, k2 sts, p2 sts, C3B, p2tog tbl. (20 sts.)

123 ★P4 sts, k2 sts, p2 sts, k2 sts★. Rep once more.

124 Dec row: P2 sts, k2 sts, p2 sts, k4 sts, p2 sts, k2 sts, p2 sts, k2 sts, k2tog. (19 sts.)

125 P3 sts, k2 sts, p2 sts, k2 sts, p4 sts, k2 sts, p2 sts, k2 sts.

126 P2 sts, k2 sts, p2 sts, k4 sts, p2 sts, k2 sts, p2 sts, k3 sts.

127 Rep step 125 once more.

128 C row: P2 sts, k2 sts, p2 sts, C4B, p2 sts, k2 sts, p2 sts, k3 sts.

129 Rep step 125 once more.

SIZE 3 ONLY:

130 K2 sts, p4 sts, ★k2 sts, p2 sts, k2 sts, p4 sts★. Rep once more, k2 sts, p2 sts, k1 st.

131 Dec row: P1 st, ★k2 sts, p2 sts, k4 sts, p2 sts★. Rep once more, k2 sts, p2 sts, k4 sts, p2tog tbl. (30 sts.)

132 K1 st, p4 sts, ★k2 sts, p2 sts, k2 sts, p4 sts★. Rep once more, k2 sts, p2 sts, k1 st.

133 Dec row: P1 st, ★k2 sts, p2 sts, k4 sts, p2 sts★. Rep once more, k2 sts, p2 sts, k3 sts, k2tog. (29 sts.)

134 P4 sts, k2 sts, ★p2 sts, k2 sts, p4 sts, k2 sts★. Rep once more, p2 sts, k1 st.

135 Dec / C row: P1 st, ★k2 sts, p2 sts, C4B, p2 sts★. Rep once more, k2 sts, p2 sts, C2B, k2tog. (28 sts.)

136 P3 sts, k2 sts, ★p2 sts, k2 sts, p4 sts, k2 sts★. Rep once more, p2 sts, k1 st.

137 Dec row: P1 st, ★k2 sts, p2 sts, k4

sts, p2 sts★. Rep once more, k2 sts, k1 st, k2tog. (27 sts.)

138 K4 sts, ★p2 sts, k2 sts, p4 sts, k2 sts★. Rep once more, k2 sts, p2 sts, k1 st.

139 Dec row: P1 st, ★k2 sts, p2 sts, k4 sts, p2 sts★. Rep once more, k2 sts, p2 sts, p2tog tbl. (26 sts.)

140 K3 sts, ★p2 sts, k2 sts, p4 sts, k2 sts★. Rep once more, p2 sts, k1 st.

141 Dec / C row: P1 st, ★k2 sts, p2 sts, C4B, p2 sts★. Rep once more, k2 sts, p1 st, p2tog tbl. (25 sts.)

142 K2 sts, ★p2 sts, k2 sts, p4 sts, k2 sts★. Rep once more, p2 sts, k1 st.

143 Dec row: P1 st, ★k2 sts, p2 sts, k4 sts, p2 sts★. Rep once more, k2 sts, p2tog tbl. (24 sts.)

144 K1 st, ★p2 sts, k2 sts, p4 sts, k2 sts★. Rep once more, p2 sts, k1 st.

145 Dec row: P1 st, ★k2 sts, p2 sts, k4 sts, p2 sts★. Rep once more, k1 st, k2tog. (23 sts.)

146 P2 sts, ★k2 sts, p4 sts, k2 sts, p2 sts★. Rep once more, k1 st.

147 C row: P1 st, ★k2 sts, p2 sts, C4B, p2 sts★. Rep once more, k2 sts.

148 Rep step 146 once more.

149 P1 st, ★k2 sts, p2 sts, k4 sts, p2 sts★. Rep once more, k2 sts.

150 Rep step 146 once more.

SIZE 4 ONLY:

151 P 1 st, k2 sts, ★p2 sts, k2 sts, p4 sts, k2 sts★. Rep twice more, p2 sts.

152 **Dec row:** K2 sts, ★p2 sts, k4 sts, p2 sts, k2 sts★. Rep twice more, p1 st, p2tog tbl. (34 sts.)

153 K2 sts, ★p2 sts, k2 sts, p4 sts, k2 sts★. Rep twice more, p2 sts.

154 **Dec / C row:** K2 sts, ★p2 sts, C4B, p2 sts, k2 sts★. Rep twice more, p2tog tbl. (33 sts.)

155 K1 st, ★p2 sts, k2 sts, p4 sts, k2 sts★. Rep twice more, p2 sts.

156 **Dec row:** K2 sts, ★p2 sts, k4 sts, p2 sts, k2 sts★. Rep once more, p2 sts, k4 sts, p2 sts, k1 st, k2tog. (32 sts.)

157 ★P2 sts, k2 sts, p4 sts, k2 sts★. Rep twice more, p2 sts.

158 **Dec row:** K2 sts, ★p2 sts, k4 sts, p2 sts, k2 sts★. Rep once more, p2 sts, k4 sts, p2 sts, k2tog. (31 sts.)

159 P1 st, k2 sts, p4 sts, k2 sts, ★p2 sts, k2 sts, p4 sts, k2 sts★. Rep once more, p2 sts.

160 **Dec / C row:** K2 sts, ★p2 sts, C4B, p2 sts, k2 sts★. Rep once more, p2 sts, C4B, p1 st, p2tog tbl. (30 sts.)

161 K2 sts, p4 sts, k2 sts, ★p2 sts, k2 sts, p4 sts, k2 sts★. Rep once more, p2 sts.

162 **Dec row:** K2 sts, ★p2 sts, k4 sts, p2 sts, k2 sts★. Rep once more, p2 sts, k4 sts, p2tog tbl. (29 sts.)

163 K1 st, p4 sts, k2 sts, ★p2 sts, k2 sts, p4 sts, k2 sts★. Rep once more, p2 sts.

164 **Dec row:** K2 sts, ★p2 sts, k4 sts, p2 sts, k2 sts★. Rep once more, p2 sts, k3 sts, k2tog. (28 sts.)

165 P4 sts, k2 sts, ★p2 sts, k2 sts, p4 sts, k2 sts★. Rep once more, p2 sts.

166 **Dec / C row:** K2 sts, ★p2 sts, C4B, p2 sts, k2 sts★. Rep once more, p2 sts, C2B, k2tog. (27 sts.)

167 P3 sts, k2 sts, ★p2 sts, k2 sts, p4 sts, k2 sts★. Rep once more, p2 sts.

168 **Dec row:** K2 sts, ★p2 sts, k4 sts, p2 sts, k2 sts★. Rep once more, p2 sts, k1 st, k2tog. (26 sts.)

169 P2 sts, k2 sts, ★p2 sts, k2 sts, p4 sts, k2 sts★. Rep once more, p2 sts.

170 K2 sts, ★p2 sts, k4 sts, p2 sts, k2 sts★. Rep once more, p2 sts, k2 sts.

171 Rep step 169 once more.

172 **C row:** K2 sts, ★p2 sts, C4B, p2 sts, k2 sts★. Rep once more, p2 sts, k2 sts.

173 Rep step 169 once more.

ALL SIZES:

174 Cast off.

ASSEMBLY & FINISHING

NOW IT'S TIME TO SEW YOUR PIECES TOGETHER!

- 1 Place the front panel on top of the back, with the wrong sides touching. Using colour B and the horizontal invisible seam technique to sew the right shoulder seam together.

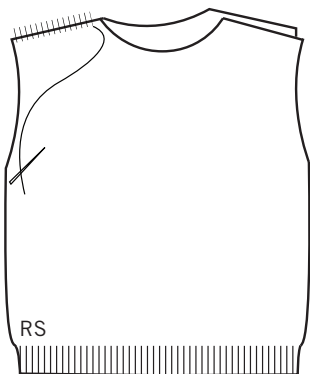

- 2 Using colour B and with 3.5mm (US4) circular needles and with the right side facing you, pick up and k a total of 93 [97:101:101] sts around the neckline as follows. Working from right to left around the neckline, pick up and k 52 [54:56:56] sts around the front neckline, until you reach the shoulder seam. Now pick up and k another 41 [43:45:45] sts along the back neck.

- 3 Work in 1x1 rib until your trim measures 3cm/1.2" (approx. 10 rows).

- 4 Using colour A, work 1 row in 1x1 rib.

- 5 Cast off in ribbing.

- 6 With the right side facing you, use colour B and the horizontal invisible shoulder seam technique to sew the second shoulder seam together. When you reach the end of your shoulder seam, continue to sew the neck trim together using the vertical invisible seam technique.

Now you will pick up sts and k the armhole trims.

- 7 Using colour B and with 3.5mm (US4) circular needles and with the right side facing you, pick up and k a total of 84 [88:92:96] sts around one armhole as follows. Pick up and k 42 [44:46:48] sts around the first half of the armhole, until you reach the shoulder seam. Now pick up and k another 42 [44:46:48] sts along the second half of the armhole.

- 8 Work in 1x1 rib until your trim measures 1.5cm/0.6" (approx. 4 rows).

- 9 Using colour A, work 1 row in 1x1 rib.

- 10 Cast off in ribbing.

- 11 Repeat steps 7 to 10 for the second armhole.

- 12** Fold your tank at the shoulder seams, with the right side facing you and using colour B, sew the side seams using the vertical invisible seam techniques.

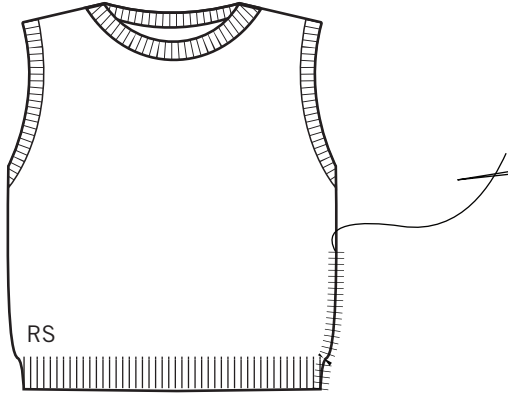

- 13** Weave in any loose ends.

KNITTING TECHNIQUES

WORK! WORK! WORK!

There are two main ways to 'work' stitches: they can be knitted or purled. When the pattern asks you to 'work' a number of stitches/rows/cm, it will always specify which stitch pattern to work in.

USING CIRCULAR NEEDLES FOR KNITTING FLAT PIECES

▶ [Online video tutorial](#)

Circular needles aren't just for knitting in the round - they are also great for knitting flat pieces, if you have more stitches than you can fit on standard straight knitting needles. As you knit, the stitches will move across from the end of the circular needle in your left hand towards the other end in your right hand - the stitches you have knitted will hang between the two needle ends. After knitting your row, simply turn the long needle around so the end of your work with the tail of yarn you are knitting with is in your left hand ready to start a new row.

LONG-TAIL CAST ON

▶ [Online video tutorial](#)

This creates a nice elastic edge, suitable for stretchy items like hats. To make sure that the edge isn't too tight, you can cast on over two knitting needles held together.

1 Start by making a slipknot - the 'yarn tail' needs to be quite long for this cast on, hence the name! Place the slipknot on your knitting needle, and hold the needle in your right hand,

with the yarn hanging straight down.

2 Now insert the thumb and index finger of your left hand between the two strands of yarn hanging from the needle, and then close your ring finger and little finger around the yarn to trap it.

Stretch out your thumb and index finger as far from each other as possible, stretching the yarn taut.

3 You will be using three separate strands of yarn:

A: the strand which sits closest to you, in front of the thumb. **B:** the strand that goes from the thumb to the slipknot on the needle. **C:** the strand that goes from the needle to your index finger

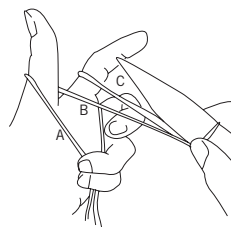

4 Place the needle in front of A, then bring it under A and let it come up between A and B.

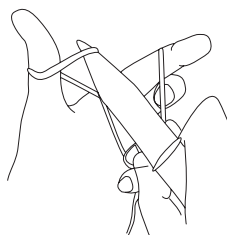

- 5 Now bring the needle over and behind C, and scoop the yarn (C) up with the tip of your needle.

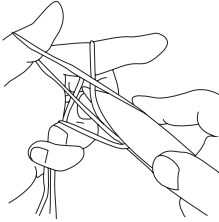

- 6 Bring the needle tip with the yarn back between A and B (the same way you came before), so that it ends up in front of A. Now pull your thumb out from the yarn that's looped around it. Tug on the yarn to tighten up the new loop on your knitting needle.
- 7 Repeat steps 2-6 to continue casting on stitches.

1X1 RIB STITCH

▶ [Online video tutorial](#)

Knit the first stitch, purl the next. Continue alternating between knit and purl stitches to the end of your row.

When working over an uneven number of stitches, repeat the following two rows:

Row 1: Knit 1 stitch, purl 1 stitch, repeat these 2 stitches until you have 1 stitch left of your row, knit the last stitch.

Row 2: Purl 1 stitch, knit 1 stitch, repeat these 2 stitches until you have 1 stitch left of your row, purl the last stitch.

To work over an even number of stitches, repeat the following row:

Row 1: Knit the first stitch, purl the next. Continue alternating between knit and purl stitches until the end of your row.

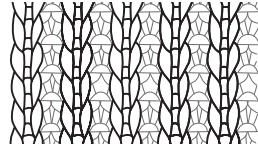

REVERSE STOCKING STITCH

▶ [Online video tutorial](#)

This is a variation of stocking stitch, where the purl side is used as the 'right' side. The 'right' side of the fabric looks like a series of 'waves' and the 'wrong' side of the fabric looks like a series of 'Vs'. Purl all the stitches of the first row (right side) and knit all the stitches of the second row. These two rows form the pattern.

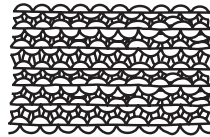

RIGHT SIDE

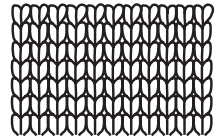

WRONG SIDE

RIGHT-LEANING DECREASE (K2TOG)

▶ [Online video tutorial](#)

Instead of knitting only one stitch at a time, knit two stitches together. Insert the front of your right needle through the first two stitches on the left needle, then knit them together as a single stitch.

LEFT-LEANING DECREASE (SSK)

▶ [Online video tutorial](#)

Insert the right needle into the next stitch on the left needle knit-wise (from left to

right) and slip the stitch onto the right needle without knitting it. Slip the next stitch in the same way. Now insert the left needle through both these stitches, in front of the right needle, from left to right. Wrap the yarn as for a normal knit stitch and pull the yarn through both loops at once.

RIGHT-LEANING PURL DECREASE (PT2OG TBL)

▶ [Online video tutorial](#)

To make a right-leaning purl decrease, you purl two stitches together through the back of the loops. Holding the yarn ready to work a purl stitch, insert the right needle into the back of the second stitch on the left needle, from left to right (behind the left needle). Then continue by inserting the needle into the first stitch as well (from left to right as before). The right needle is now parallel to the left needle, with the right needle behind the left, and both needle tips pointing in the same direction. Wrap the yarn and complete the stitch as for a normal purl stitch.

LEFT-LEANING PURL DECREASE (P2TOG)

▶ [Online video tutorial](#)

Insert the right needle through the next two stitches and purl them together as if they were a single stitch.

INCREASING

▶ [Online video tutorial](#)

Make a new stitch by inserting the left needle from front to back under the strand of yarn between the last stitch worked and the next stitch to be worked, and lifting this loop onto the needle. Now insert the right needle into this loop from right to left, then wrap the yarn and pull through as for a knit stitch.

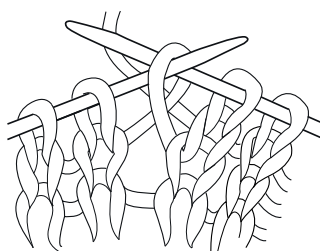

CABLE KNITTING TECHNIQUE

▶ [Online video tutorial](#)

Knitting with cables is actually easier than it looks! You'll need a **cable needle**, which is a small knitting needle that is pointy at both ends.

The stitches that form your cable will normally be worked in stocking stitch. Every few rows, you will **twist** your cable - this is done by slipping the first few stitches of your cable onto the cable needle and holding this either in front of your work or behind it (the pattern will tell you which). Next, you knit the rest of the stitches from your cable (the ones that are on your left-hand knitting needle). Finally, knit the stitches from the cable needle - you have now twisted your cable!

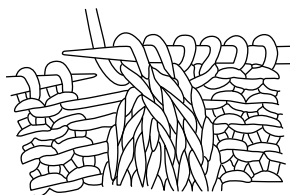
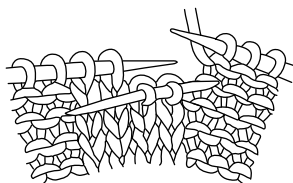

PICKING UP STITCHES

▶ [Online video tutorial](#)

To pick up stitches along a cast off edge, insert the right needle through the first cast off stitch from front to back, taking care to catch both of the vertical yarn 'loops' at the top of the stitch. Wrap the yarn around the needle and pull through as for a normal knit stitch. Now do the same for the next stitch along the edge.

To pick up stitches along the side edge of your knitting, insert the right needle through the first edge stitch from front to back. Wrap the yarn around the needle and pull through as for a normal knit stitch. Now do the same for the next stitch along the edge, one row above or below.

Sometimes it is necessary to pick up more or fewer stitches than the number of stitches along your edge - to do this, you can pick up two new stitches through the same stitch, or not pick up through all your stitches. The second stitch will look like a yarn over. When you work back along these stitches, work the second stitch through the back of the stitch.

ADDING A NEW BALL OF YARN

▶ [Online video tutorial](#)

When your ball of yarn runs out, or when you need to change the colour, tie a loose knot on to the tail with the new ball of yarn, slide it up to the needle and tighten the knot. Then continue knitting with the new yarn. If there is no tail end to tie your new ball to then simply wrap the new ball's tail end around your needle and continue knitting as normal.

CASTING OFF

▶ [Online video tutorial](#)

To complete your project, you need to cast off your last row of stitches in order to make an edge that won't unravel. For your final row, knit the first two stitches. Using the tip of the left needle, lift the first stitch up and over the second stitch and then slip it off the right needle. Now you have only one stitch on your right needle. Knit the next stitch from the left needle, then lift the previous stitch over it and off the needle as before. Do this with each stitch until there are no stitches on the left needle and just one stitch on the right needle. Cut the yarn, leaving a 15 cm/6" end. Pull on the last loop until the ends pops through - you've now secured the last stitch.

CASTING OFF IN RIBBING

▶ [Online video tutorial](#)

To create a stretchy edge, cast off in ribbing. To do this, knit one stitch, then purl one stitch. Use the tip of the left needle to lift the first stitch over the last one, and off the needle. Knit the next stitch, and lift the previous stitch over it and off the needle. Purl the next stitch, and lift the previous stitch over it and off the needle. Repeat the last two stitches, so that you are alternating between knit and purl stitches as you cast off.

FINISHING TECHNIQUES

VERTICAL INVISIBLE SEAM

▶ [Online video tutorial](#)

This technique is used to join the side edges of two pieces. Place the two knitted pieces side by side with the right sides up. Insert your sewing needle under the first horizontal bar between the first two stitches on the edge you want to join. Pull the yarn through and insert the needle through the opposite horizontal bar on the other piece. Sew back and forth through the horizontal bars along the edge. To tighten the stitches, pull the yarn gently – and they will disappear.



HORIZONTAL INVISIBLE SEAM

▶ [Online video tutorial](#)

This technique is used for sewing together horizontal edges (like cast on and cast off edges). Align the two edges so that they are lined up stitch by stitch. Insert the sewing needle under a V stitch and then under the corresponding V stitch on the other side. Continue in this way until the seam is complete.

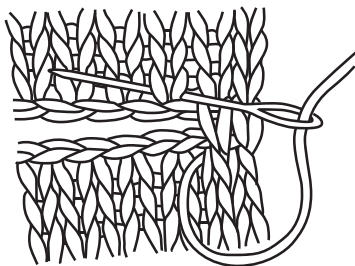

WEAVING IN THE ENDS

▶ [Online video tutorial](#)

Weave the ends of your yarn into your knitting to finish it off and stop it from unravelling. Thread the tail onto the sewing needle. Weave the yarn along the edge of your knitting as shown in the illustration. Where you have started a new ball, weave one tail in one direction and the other tail in the opposite direction. Weave in approximately 10 cm/4", then cut the tail.

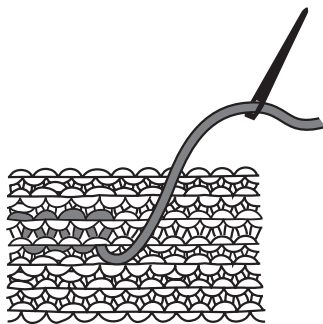

A series of 25 horizontal dotted lines for writing.

YOUR PROJECT DESERVES SOME SEXY YARN



CRAZY SEXY WOOL

100% Peruvian Wool

Laine Péruvienne
Peruanische Wolle



HEAL THE WOOL

100% Recycled Wool

Laine recyclé
Recycelte Wolle



LIL' HEAL THE WOOL

100% Recycled Wool

Laine recyclé
Recycelte Wolle



ALPACHINO MERINO

60% Merino / Laine

Mérinos / *Merino Wolle*
40% Baby Alpaca / Baby
Alpaga / Baby Alpaka



JERSEY BE GOOD

98% Cotton / Coton

Baumwolle

2% Elastane / Elasthanne

Elastan



TINA TAPE YARN

100% Tencel®

Tencel®

Tencel®



MIXTAPE YARN

80% Cotton / Coton

Baumwolle

20% Polyester / Polyester

Polyester



RA-RA RAFFIA

100% Paper

Fibre de bois

langfaseriges Holz



SUGAR BABY ALPACA

100% Baby Alpaca

Baby alpaga

Baby Alpaka



SHINY HAPPY COTTON

100% Peruvian Pima

Cotton / Coton Pima

Péruvien / *Peruanische*

Pima-Baumwolle



BILLIE JEAN

YARN

100% Upcycled Denim

Denim recyclé

Upcycled Denim



BACK FOR GOOD

CASHMERE

97% Recycled Cashmere

Cachemire recyclé

Recyceltes Kaschmir

3% Recycled Wool / Laine

recyclée / *Recycelte Wolle*



BUDDY HEMP YARN

55% Hemp

Chanvre / *Hanf*

45% Organic Cotton

Coton organique

Bio-Baumwolle



FEELING GOOD YARN

70% Baby Alpaca / Baby

Alpaga / Baby Alpaka

7% Merino / Mérinos

Merino

23% Nylon

Nylon / Nylon



TAKE CARE MOHAIR

78% Kid Mohair / Kid

mohair / Kid Mohair

13% Wool / Laine / Wolle

9% Polyamide

Polyamide / Polyamid



NEW WAVE YARN

53% Cotton

coton / *Baumwolle*

47% Recycled Polyester

Polyester recyclé

recyceltes Polyester

WOOL AND THE GANG

Wool and the Gang

@woolandthegang



© Wool and the Gang LTD. 2023

V462744574

