

# WOOL AND THE GANG

#MADEUNIQUE



## DOT COTTON SWEATER

**ADVANCED**

**6.5MM HOOK**

© Wool and the Gang LTD. 2015

# YOUR ADVENTURE STARTS NOW

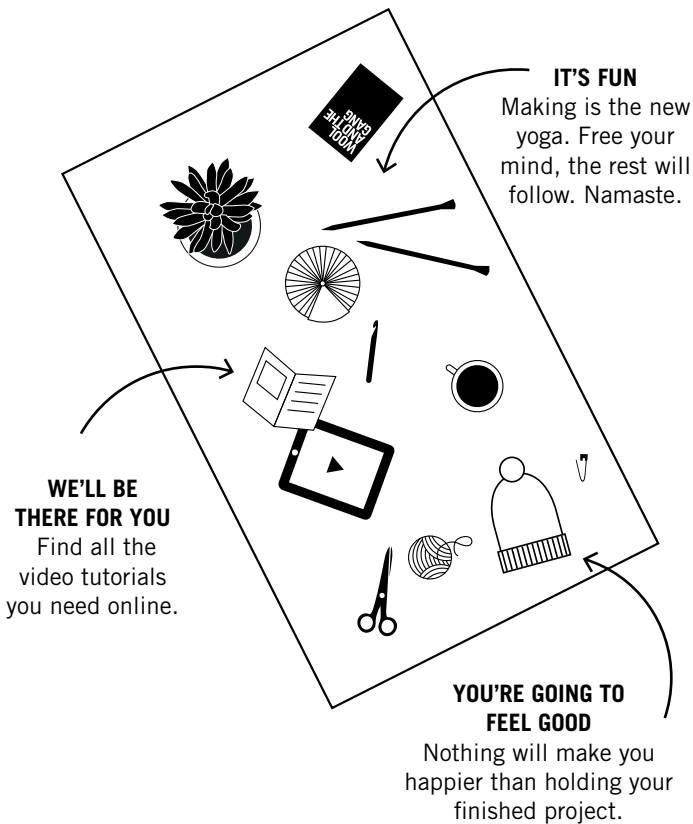

## IT'S FUN

Making is the new yoga. Free your mind, the rest will follow. Namaste.

## WE'LL BE THERE FOR YOU

Find all the video tutorials you need online.

## YOU'RE GOING TO FEEL GOOD

Nothing will make you happier than holding your finished project.

# RECIPE FOR SUCCESS

1

## **GET YOUR TOOLS READY.**

Everything you need to get making.

---

2

## **FAMILIARISE YOURSELF WITH THE TECHNIQUES.**

Everything from the stitches used to the finishing touches for your project.

---

3

## **GET TO KNOW YOUR YARN.**

Before you start your piece, play around with your new yarn to get used to it, and to check your tension.

---

4

## **WOOL SCHOOL**

Pick up your needles & yarn and make the magic happen! For a little extra help, check out our Wool School at:

**[www.woolandthegang.com/t/how-to](http://www.woolandthegang.com/t/how-to)**

---

5

## **#WOOLANDTHEGANG**

When you're done - let the world know.

# LET'S GET CROCHETING

## Tool kit

- 5 balls of WATG's Shiny Happy Cotton in colour A
- 1 ball of WATG's Shiny Happy Cotton in colour B
- 1 ball of WATG's Shiny Happy Cotton in colour C
- 1 ball of WATG's Shiny Happy Cotton in colour D
- 1 ball of WATG's Shiny Happy Cotton in colour E
- 1 Dot Cotton Sweater pattern
- 1 6.5mm crochet hook
- 1 sewing needle

## A note on colours

Colour A is the main colour, and is also used on the 7th and 10th rounds of the crochet square. Colour B is used at the centre of the square and as you're working out from the centre of the square, you will also use colours C, D and E.

## Tension

To ensure your crochet project has the same measurements as the pattern, it is a good idea to make a tension swatch before you start. A tension swatch is a small sample of crochet where you count the stitches and rows and check them against the tension given in the pattern. If you get MORE stitches/rows than the pattern's tension, it means your crochet is TIGHTER. If you get FEWER stitches/rows than the pattern, your crochet is LOOSER. Sometimes, it works to crochet tighter or looser to compensate.

## Double crochet

- 10cm/4" = 11.5 stitches
- 10cm/4" = 6 rows

**All crochet techniques can be found at the back of the pattern.**

# MEASUREMENTS

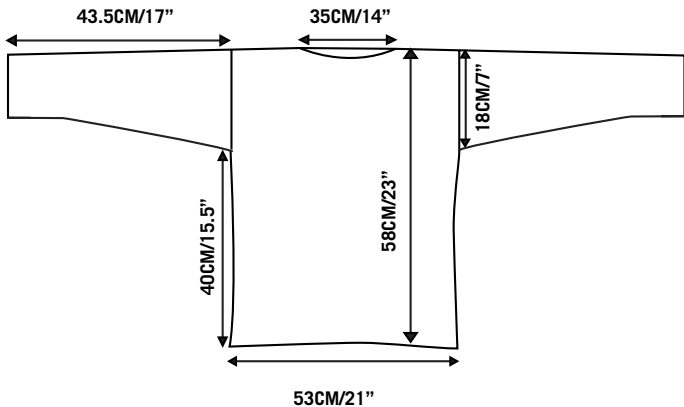

Help's only a stitch away. Watch the video tutorials online at [www.woolandthegang.com/video\\_s](http://www.woolandthegang.com/video_s)

Pssst! Remember that you must not copy our patterns and sell, or even give them away for free, in accordance with copyright law. Also, you must not sell any articles made from our patterns.

# HOW TO CROCHET YOUR DOT COTTON SWEATER

You will start by making four identical crochet squares. These squares will form the motifs on the front, back and sleeves of the sweater. You will then extend two of the squares into rectangles. The remainder of the body is worked in one piece, joining the two rectangular motifs as you work. Finally, you will join the sleeves.

## SQUARE MOTIF

Follow the instructions 4 times to make your square motifs.

- 1 With colour B, make a foundation chain of 4 chain stitches. Join your stitches into a little circle by working a slip stitch into the first stitch of the round.

---

- 2 Make 3 chain stitches. You will now make your first round of double crochet - but instead of working into each stitch in the regular way, work your stitches around the ring of chain stitches. This means that rather than inserting the hook into the middle of each stitch, you insert it into the middle of the foundation ring.

Make 2 double crochet stitches. Make 2 chain stitches.

★Make 3 double crochet stitches, then make 2 chain stitches.★

Repeat the section inside the stars twice more. Join your round by working a slip stitch into into the 3rd chain stitch at the beginning of the round. (20 stitches.)

### 3 Make 3 chain stitches.

★Make 1 chain stitch, then work the following sequence into the next chain space: 3 double crochet stitches, 2 chain stitches, 3 double crochet stitches.★

Repeat the section inside the stars twice more. Make 1 chain stitch, then work the following sequence into the last chain space: 3 double crochet stitches, 2 chain stitches, and 2 double crochet stitches. (36 stitches.)

Join the round as before. Cut colour B approx. 15cm/6" from the last stitch. Pull on the loop on your crochet hook until the end pops through (you have now secured the last stitch).

To make the instructions easier to read, we will now use some simple abbreviations:

CH1 = make 1 chain stitch

CH2 = make 2 chain stitches

CH3 = make 3 chain stitches

DC1 = make 1 double crochet stitch

DC2 = make 2 double crochet stitches

DC3 = make 3 double crochet stitches

A sequence in brackets - like this: [DC1, CH1, DC1] - means that all the stitches will be worked into the same stitch or chain space.

- 4** Insert your hook into the first stitch and draw through colour C. CH3. DC2 into the first chain space.

★Make 1 chain stitch, then work the following sequence into the next chain space: 3 double crochet stitches, 2 chain stitches, 3 double crochet stitches. Make 1 chain stitch, work 3 double crochet stitches into the next chain space.★

Repeat the section inside the stars twice more. CH1, [DC3, CH2, DC3] into the next chain space. CH1. (52 stitches.) Join the round as before.

---

- 5** CH4, DC3 into the next chain space.

★CH1, [DC3, CH2, DC3] into the next chain space. Work the following sequence twice: CH1, DC3 into the next chain space.★

Repeat the section inside the stars twice more. CH1, [DC3, CH2, DC3] into the next chain space. CH1, DC2 into the next chain space. (68 stitches.)

Join the round as before. Cut the yarn and secure the last stitch.

---

- 6** Insert your hook into the first stitch and draw through colour D. CH3. DC2 into the first chain space. CH1, DC3 into the next chain space.

★CH1, [DC3, CH2, DC3] into the next chain space.

---



Work the following sequence 3 times: CH1, DC3 into the next chain space.★

Repeat the section inside the stars twice more. CH1, [DC3, CH2, DC3] into the next chain space. CH1, DC3 into the next chain space. CH1. (84 stitches.)

Join the round as before.

---

- 7** CH3. Work the following sequence twice: CH1, DC3 into the next chain space.

★CH1, [DC3, CH2, DC3] into the next chain space. Work the following sequence 4 times: CH1, DC3 into the next chain space.★

Repeat the section inside the stars twice more. CH1, [DC3, CH2, DC3] into the next chain space. CH1, DC3 into the next chain space. CH1, DC2 into the next chain space. (100 stitches.)

Join the round as before. Cut the yarn and secure the last stitch.

---

- 8** Insert your hook into the first stitch and draw through colour A. CH3. DC2 into the first chain space. Work the following sequence twice: CH1, DC3 into the next chain space.

★CH1, [DC3, CH2, DC3] into the next chain space. Work the following sequence 5 times: CH1, DC3 into the

---

next chain space.★

Repeat the section inside the stars twice more. CH1, [DC3, CH2, DC3] into the next chain space. Work the following sequence twice: CH1, DC3 into the next chain space. CH1. (116 stitches.)

Join the round as before. Cut the yarn and secure the last stitch.

- 
- 9** Insert your hook into the first stitch and draw through colour E. CH3. CH3. Work the following sequence 3 times: CH1, DC3 into the next chain space.

★CH1, [DC3, CH2, DC3] into the next chain space. Work the following sequence 6 times: CH1, DC3 into the next chain space.★

Repeat the section inside the stars twice more. CH1, [DC3, CH2, DC3] into the next chain space. Work the following sequence twice: CH1, DC3 into the next chain space. CH1, DC2. (132 stitches.) Join the round as before. Cut the yarn and secure the last stitch.

- 
- 10** Insert your hook into the first stitch and draw through colour B. CH3. DC2 into the first chain space. Work the following sequence 3 times: CH1, DC3 into the next chain space.

★CH1, [DC3, CH2, DC3] into the next chain space.

Work the following sequence 7 times: CH1, DC3 into the next chain space.★

Repeat the section inside the stars twice more. CH1, [DC3, CH2, DC3] into the next chain space. Work the following sequence 3 times: CH1, DC3 into the next chain space. CH1. (148 stitches.)

Join the round as before. Cut the yarn and secure the last stitch.

- 
- 11** Insert your hook into the first stitch and draw through colour A. CH3. CH3. Work the following sequence 4 times: CH1, DC3 into the next chain space.

★CH1, [DC3, CH2, DC3] into the next chain space. Work the following sequence 8 times: CH1, DC3 into the next chain space.★

Repeat the section inside the stars twice more. CH1, [DC3, CH2, DC3] into the next chain space. Work the following sequence 4 times: CH1, DC3 into the next chain space. CH1. (164 stitches.)

Join the round as before. Cut the yarn and secure the last stitch.

## RECTANGULAR MOTIF

Follow the instructions twice to make 2 of your squares into rectangles. You will only be working on a single side of each square.

- 1 Insert your hook into one of the corner chain spaces in the final round of your crocheted square motif and pull through colour E. It is not important which corner you work into as all are identical at this point.
- 

- 2 CH3. ★CH1, DC3 into the next chain space.★

Repeat the section inside the stars until you get to the next corner chain space on this side of the square. CH1, DC1 into the corner chain space. Cut the yarn and secure the last stitch. Turn your piece around, ready to crochet back across the stitches you just worked.

---

- 3 Insert your hook into the last stitch of the previous row and pull through colour B. CH3, DC2 into the next chain space.

★CH1, DC3 into the next chain space.★

Repeat the section inside the stars until you have 1 chain space left of your row. DC2 into the next chain space. DC1 into the final stitch of the row. Cut the yarn and secure the last stitch. Turn your work.

---

- 4 Insert your hook into the last stitch of the previous row and pull through colour C. CH3.
-

★CH1, DC3 into the next chain space.★

Repeat the section inside the stars until you have 1 chain space left of your row. CH1, DC1 into the last chain space. Cut the yarn and secure the last stitch. Turn your work.

---

- 5** Insert your hook into the last stitch of the previous row and pull through colour D. CH3, DC2 into the next chain space.

★CH1, DC3 into the next chain space.★

Repeat the section inside the stars until until you have 1 chain space left of your row. DC2 into the last chain space. DC1 into the final stitch of the row. Cut the yarn and secure the last stitch. Turn your work.

---

- 6** Insert your hook into the last stitch of the previous row and pull through colour A. CH3.

★CH1, DC3 into the next chain space.★

Repeat the section inside the stars until until you have 1 chain space left of your row. CH1, DC1 into the last chain space. Cut the yarn and secure the last stitch.

---

## **BODY - SIDE SECTION**

You will now make the sides of your sweater. Follow the instructions twice to make both sides.

- 1** With colour A, make a foundation chain of 25 chain stitches. Turn your piece around, ready to crochet back across the stitches you just worked.

---

- 2** Work across these 25 stitches in double crochet until the side edge of your piece is the same length as the side edge of your rectangular motifs. This should be approx. 40cm/15.5" (25 rows) from the foundation chain edge.

---

- 3** Work in double crochet across the first 12 stitches of your row. Tie a piece of scrap yarn through your last stitch to stop your work unravelling but do not cut your yarn. You will come back and work from this stitch later.

## **BODY - TOP SECTION**

You will now split your work to create your armholes and begin to work across the front and back top sections of your sweater.

- 1** Pick up the live stitch of your first side panel (both panels are identical so it isn't important which). CH3. DC12 across the same stitches you created in step 3 of the Body - Side Section.

You will work your next stitches across the top edge of

your rectangular motif. This will incorporate it into the body of your sweater without having to seam it in later.

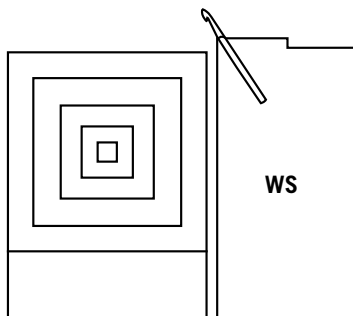

- 2 Lay your rectangular motif next to the piece attached to your hook so that its last worked row aligns with the foundation row on the bottom edge of the side panel.

- 
- 3 Work from right to left across the top edge of your motif panel as follows: DC1 into the top right corner chain space. Skip 1 stitch, DC2.

★DC1 into the next chain space, DC3.★

Repeat the section inside the stars a further 7 times. DC1 into the next chain space. Skip 1 stitch, DC2. DC1 into the top left corner chain space. (50 stitches.)

---

You will now work your stitches across the top edge of your second side panel. This will join both front and back together and avoid seaming together later.

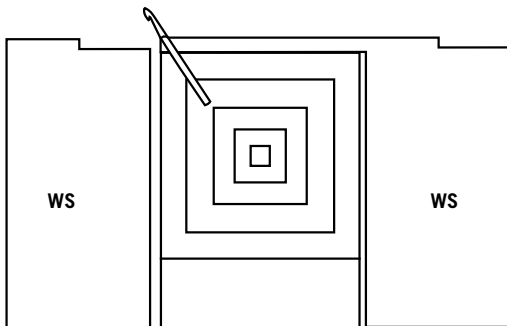

**4** Lay your second side panel next to the piece attached to your hook so that their bottom edges align.

---

**5** DC12 across your second side panel. You will have worked 62 stitches across your two side panels and your rectangular motif. Turn your piece around ready to work back across the stitches you just worked.

---

**6** Work 6 rows in double crochet.

---

**7** CH3, DC10, SC42. DC10.

Cut your yarn approx. 15cm/6" from the last stitch. Pull on the loop on your crochet hook until the end pops through (you have now secured the last stitch).

You have now finished working one side of your body (both front and back are identical so you can choose your favourite) and will now move on to the other side.



- 8** Pick up the saved stitch of your second side panel. CH3. Working away from the already incorporated motif rectangle, and across the 12 double crochet stitches created in step 5 of the BODY - SIDE SECTION instructions, DC12.

You will work your next stitches across the top edge of your second rectangular motif.

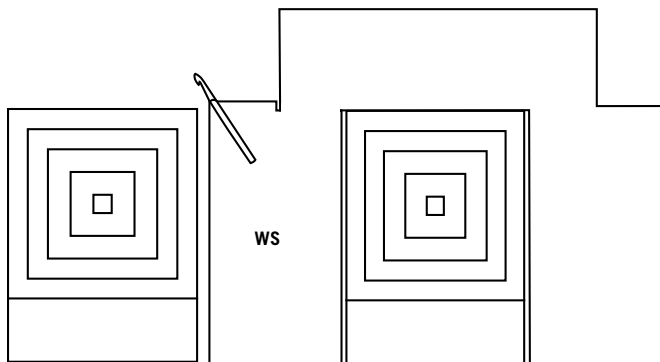

- 9** As you did for your first side, lay your second rectangular motif next to the piece attached to your hook so that their bottom edges align.
- 
- 10** Work from right to left across the top edge of your motif panel as follows: DC1 into the top right corner chain space. Skip 1 stitch, DC2.

★DC1 into the next chain space, DC3.★

Repeat the section inside the stars a further 7 times.  
DC1 into the next chain space. Skip 1 stitch, DC1 into the next 2 stitches. DC1 into the top left corner chain space. (50 stitches.)

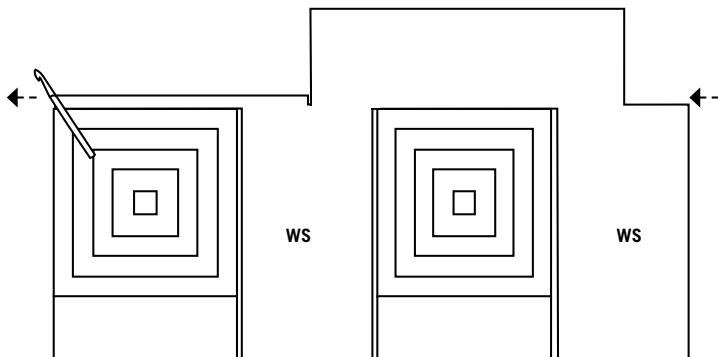

You are now going to start working in the round, so the next stitches you'll be working across are the ones from your first side panel.

- 
- 11** DC12 across your first side panel. (62 stitches). Turn your piece around ready to work back across the stitches you just worked.
- 
- 12** Repeat steps 6 and 7.
-

## ASSEMBLY AND FINISHING

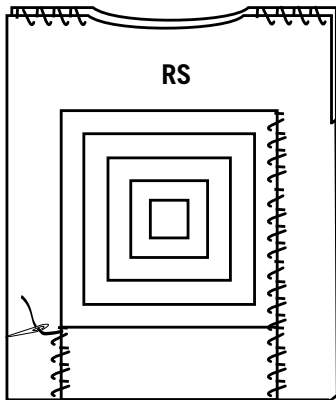

- 1 Lay your main body piece flat, with the right side facing out, so that the rectangle motifs are on top of each other and the single crochet sections of the top edges align.

---

- 2 Use the whip stitch technique to sew the shoulders together for 14cm/5.5» (leaving a neck opening of 25cm/10»).

---

- 3 Use the whip stitch technique to sew the sides of the rectangle motif into the sides of the body.

## ATTACHING THE SLEEVES

- 1 With the right side facing out, fold your first sleeve in half so the long edges meet, and locate the centre point at the top edge - this should line up with the shoulder seam of the body.

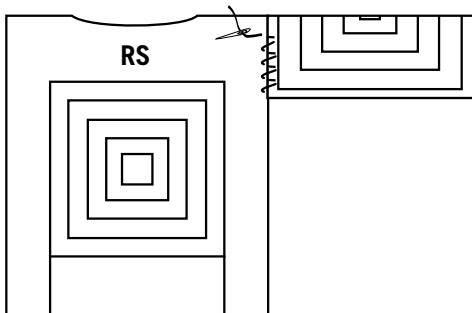

- 2 Use the whip stitch technique to attach the sleeve.
- 3 Repeat for the other sleeve.

## SLEEVE JOIN

You will join the edge of your sleeves using a decorative crochet join. Repeat these steps twice to attach both of your sleeves.

- 1 With the right side facing out, fold your sleeves so the

long edges meet. Starting at the right-hand corner of the lower edge, insert your crochet hook through the corner chain space and pull through colour A.

---

**2** CH2, make a slip stitch into the corresponding stitch on the other side edge.

---

**3** Work the following sequence twice: CH1, SC1 into the next double crochet cluster on the other side edge.

---

**4** Work the following sequence twice: CH1, SC1 into the next chain space on the other edge.

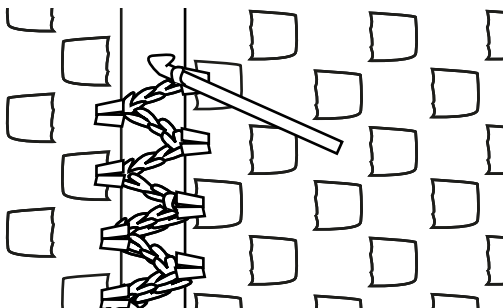

Repeat steps 3 and 4 until you have completed the sleeve join. Make a slipstitch into the underarm of the body. Cut the yarn and secure the last stitch.



Help's only a stitch away. Watch the video tutorials online at [www.woolandthegang.com/videos](http://www.woolandthegang.com/videos)

## CROCHET TECHNIQUES

### Crochet hook

The crochet hook is your tool on the path to greatness! Your pattern may refer to different parts of the crochet hook - here is an illustration to help you understand it all a little better.

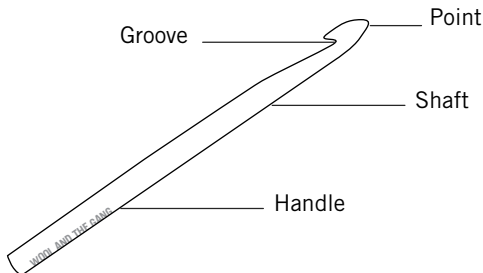

### Turning chains / [Online video tutorial](#)

When working in crochet, you often need to do a 'turning chain' at the beginning of your row. This creates a stitch that 'lifts' you up to the next level, so you're ready to crochet the next row. The turning chain is made up of chain stitches, and the number of stitches varies between different types of stitches. (Your pattern will tell you how many stitches to use for the stitch you're working in.)

## Chain stitch / [▶ Online video tutorial](#)

This is the foundation of most crochet work and can also be used as a technique on its own.

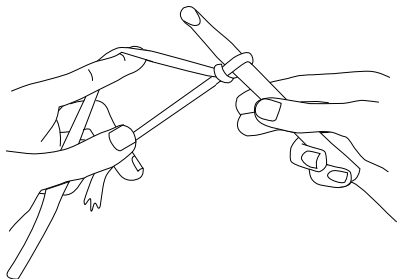

1. Make a slipknot and place it on the shaft of your crochet hook. Hold the hook in your right hand and the yarn in your left hand.

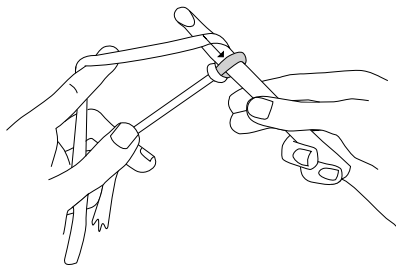

2. Move the point of the crochet hook **UNDER** the yarn from left to right, then move it **OVER** the yarn from right to left. The yarn is now looped around your crochet hook.

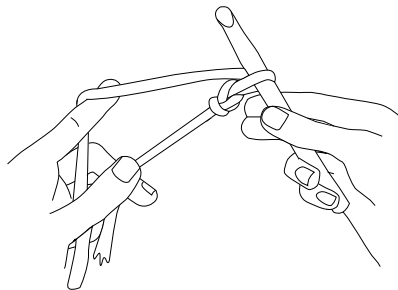

3. Scoop up the yarn with the groove of the hook, and pull it through the loop already on your hook. Slide the new stitch towards the shaft of the hook. You've now made one chain stitch.

Repeat steps 2 and 3 to keep creating new stitches. Take care not to pull your stitches too tightly! When counting your stitches, count each of the loops except the one on your hook.

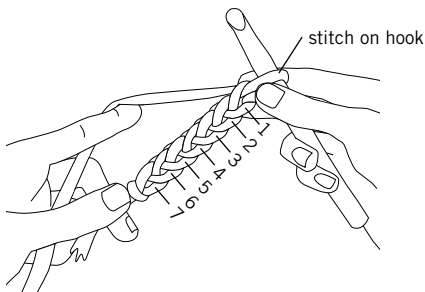

To make a chain stitch in the main body of your piece (for example, to make a turning chain), repeat steps 2 and 3.



## Chain spaces

This technique is used as a decorative stitch and creates a 'space' in your crochet. You create the 'space' by skipping stitches in your row and instead working some stitches in chain stitch - this creates a loop in your crochet. On the next row, instead of inserting your hook into stitches in the regular way, you insert your hook into the space between the chain of stitches and the row below, so the chain ends up being covered by the new stitches.

## Single crochet / [▶ Online video tutorial](#)

This stitch is one of the most basic crochet stitches. It uses a turning chain of 1 stitch.

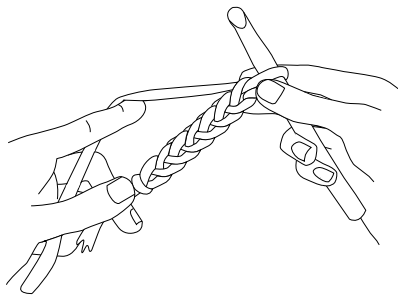

To work into a foundation chain at the beginning of your work, start with your hook in your right hand and the work in the left. Work across your foundation chain from right to left.

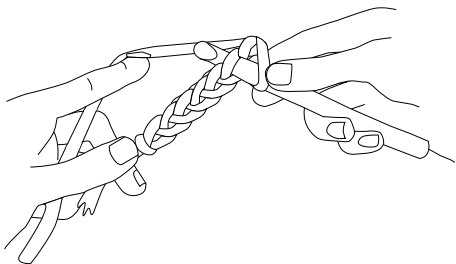

1. Insert your crochet hook into the middle of the second stitch from the hook (not counting the stitch on the hook!).

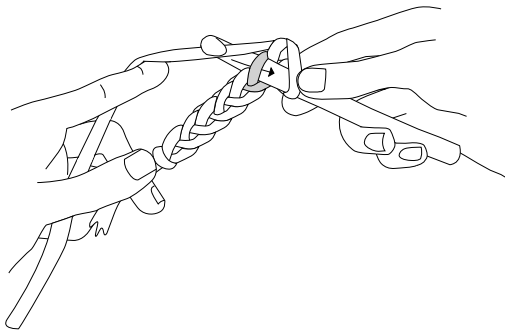

2. Move the hook under and then over the yarn. Scoop the yarn with the groove of your hook, and pull it through the stitch. There are now two loops on your hook.

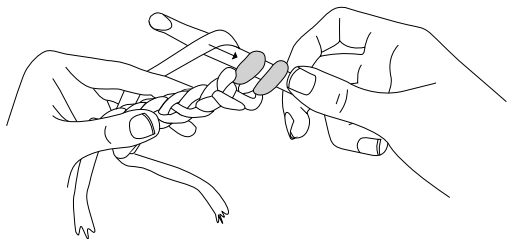

3. Loop the yarn around the hook again, and pull the yarn through BOTH of the loops on your hook. You have now worked one stitch in single crochet, and there's a single stitch on your hook again.

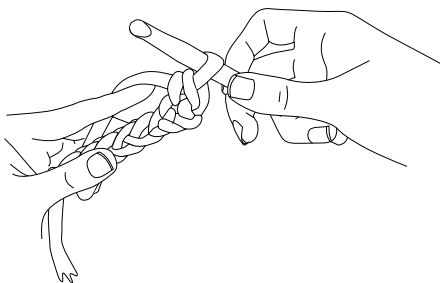

4. To continue working in single crochet, insert the hook into the next stitch of your row and repeat steps 2 and 3.

## Double crochet / [▶ Online video tutorial](#)

This stitch is taller than both single and half double crochet. It uses a turning chain of 3 stitches.

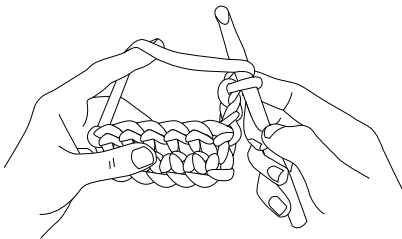

1. Make 3 chain stitches (this is your turning chain). Starting with the hook in front of the yarn, move the hook underneath the yarn, and then over it, so the yarn ends up looped around the shaft of the hook.

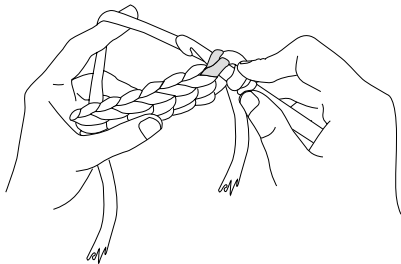

2. Insert the hook into the middle of the next stitch, underneath both strands of the sideways 'V' at the top.

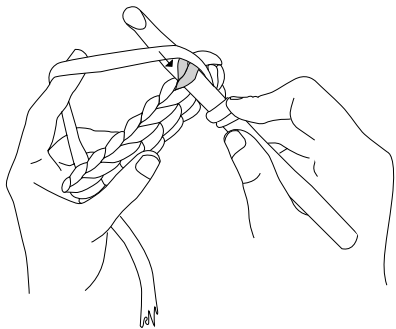

3. Loop the yarn around the groove of the hook, and pull it through the stitch and up onto the shaft of the hook. There are now three loops on your hook.

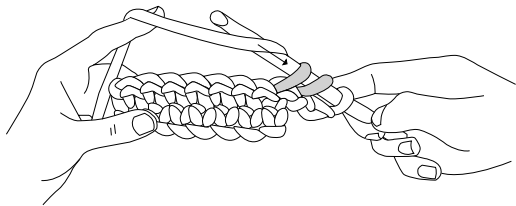

4. Loop the yarn around the hook again, and pull the yarn through two of the three loops on your hook. You now have two loops left on your hook.

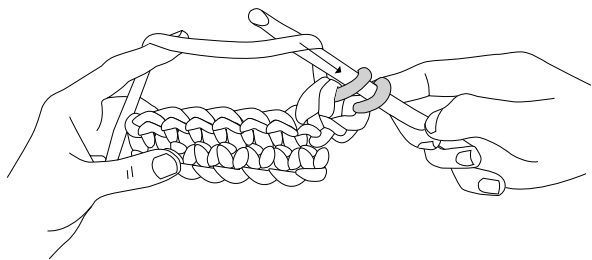

5. Loop the yarn around your hook once more and draw through BOTH of the loops on your hook. There is now a single loop left on your hook and you have worked one stitch in double crochet.

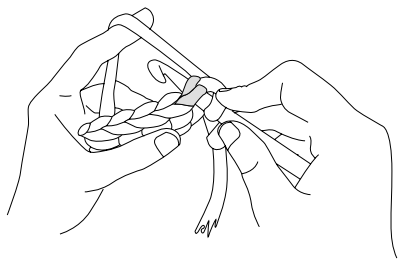

6. To continue working in double crochet, loop the yarn around the hook again, and repeat steps 2 to 5.

To work into a stitch that was crocheted on the previous row, insert your crochet hook underneath **both strands** of the sideways 'V' at the top of the next stitch, then repeat steps 2 and 3.

### **Slip stitch / [▶ Online video tutorial](#)**

Insert your crochet hook into the next stitch. Starting with the hook in front of the yarn, move the hook under and then over the yarn, so the yarn ends up looped around the shaft of the hook. Scoop up the yarn with the groove of your hook and pull it through both the stitch and the loop on your hook. You now have a single loop on your hook. You have worked one slip stitch.

### **Adding a new ball of yarn / [▶ Online video tutorial](#)**

To add a new ball of the same colour, start your stitch in the regular way, but stop before working the final wrap-around (for single crochet: insert the hook, loop your yarn, pull the yarn through and then stop!) At this point, loop your new yarn around the hook, leaving a long tail of the new yarn, and pull the new yarn through the remaining two loops to finish the stitch.

## FINISHING TECHNIQUES

### Whip stitch

This is a simple way of joining two pieces of crochet.

1. Place the two crocheted pieces together with the right sides facing you.
2. Thread your sewing needle with a strand of yarn, and secure it to the wrong side of the fabric.
3. Insert your sewing needle through the first stitch of your row and, working from the inside of your piece to the outside, pull the yarn through your first piece.
4. Insert your sewing needle into the next stitch in your second piece of fabric, and push it back from outside to inside. Pull the yarn through.
5. Move back to your first piece and work from inside to outside once more.
6. Continue in this way until your seam is done.

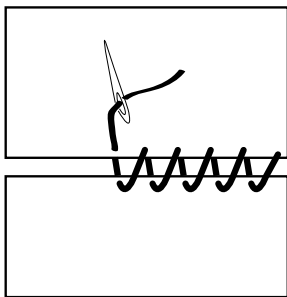



## Hiding your yarn ends

To hide the tail of your yarn, turn your work so the wrong side is facing you. Thread your sewing needle with the yarn end, and sew horizontally across your work, inserting needle and yarn underneath the back two strands of your crocheted stitches. Work like this for a few stitches, then move down a row and work back in the opposite direction. Finally, cut the yarn close to the fabric.

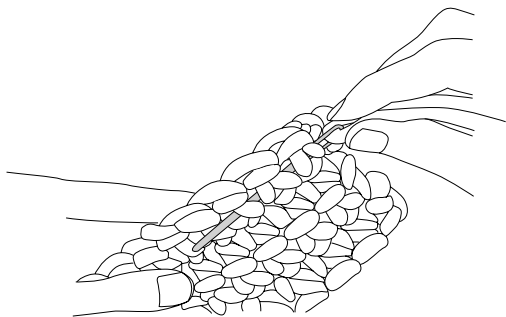

# MAKING MEMOIRS

STARTED ON .....

FINISHED ON .....

WHERE I MADE IT

- .....

- .....

- .....

MADE FOR

Me     .....

COLOUR COMBO .....

THIS PROJECT WAS

( ) easy peasy ( ) nice ( ) challenging ( ) hardcore

I FEEL    

OTHER THOUGHTS .....

.....





1"

2"

3"

4"

5"



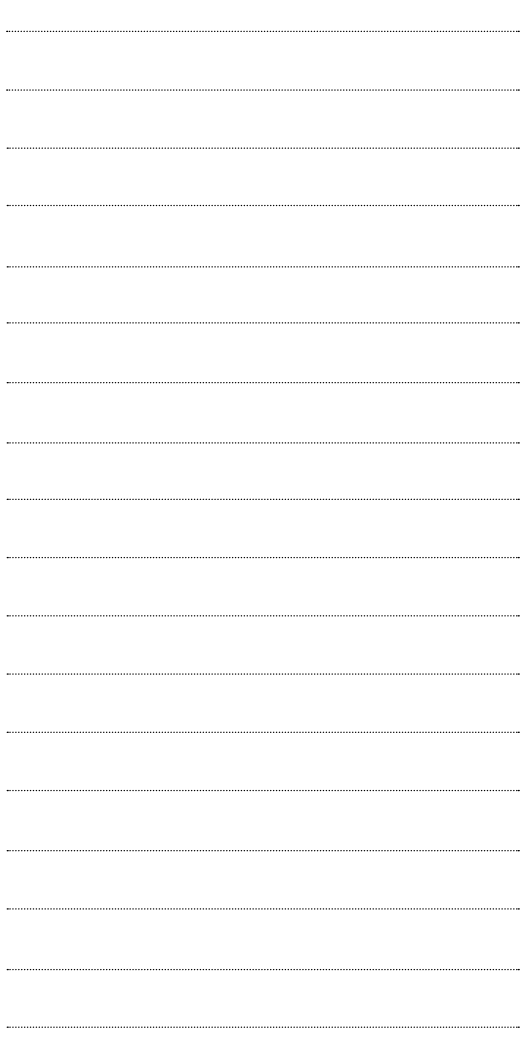

**5 CM**

**10 CM**



**Wool and the Gang**



**@woolandthegang**



**@woolandthegang**



**WATGsnaps**



**Wool and the Gang**



**woolandtheganghq**

# YOUR PROJECT DESERVES SOME SEXY YARN



**CRAZY SEXY WOOL**  
100% Peruvian Wool



**SUGAR BABY ALPACA**  
100% Baby Alpaca



**WOOL ME TENDER**  
100% Peruvian Wool



**JERSEY BE GOOD**  
98% Cotton  
2% Elastane



**MIXTAPE YARN**  
80% Cotton  
20% Polyester



**BILLIE JEAN**  
100% Upcycled Denim



**SHINY HAPPY COTTON**  
100% Peruvian  
Pima Cotton



**WOOLY BULLY ALPACA**  
80% Superfine Alpaca  
20% Merino Wool



**SHEEPACA YARN**  
50% Baby Alpaca  
50% Merino Wool



**TAKE CARE MOHAIR**  
78% Kid Mohair  
13% Wool / 9% Polyamide



**FEELING GOOD**  
70% Baby Alpaca  
7% Merino / 23% Nylon

#  
**WOOL  
AND THE  
GANG**

V207345007

