

WOOL AND THE GANG

#MADEUNIQUE

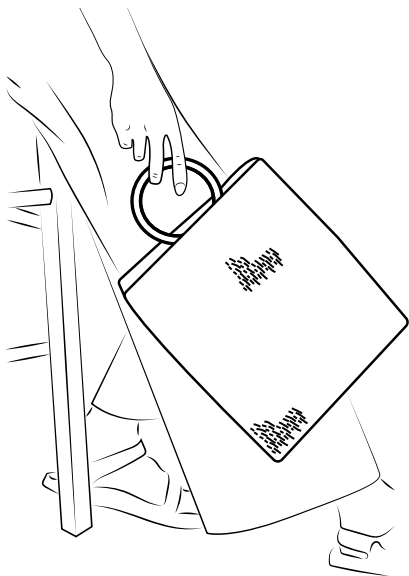

DIAMOND HEART BAG

INTERMEDIATE

4.5MM HOOK

YOUR ADVENTURE STARTS NOW

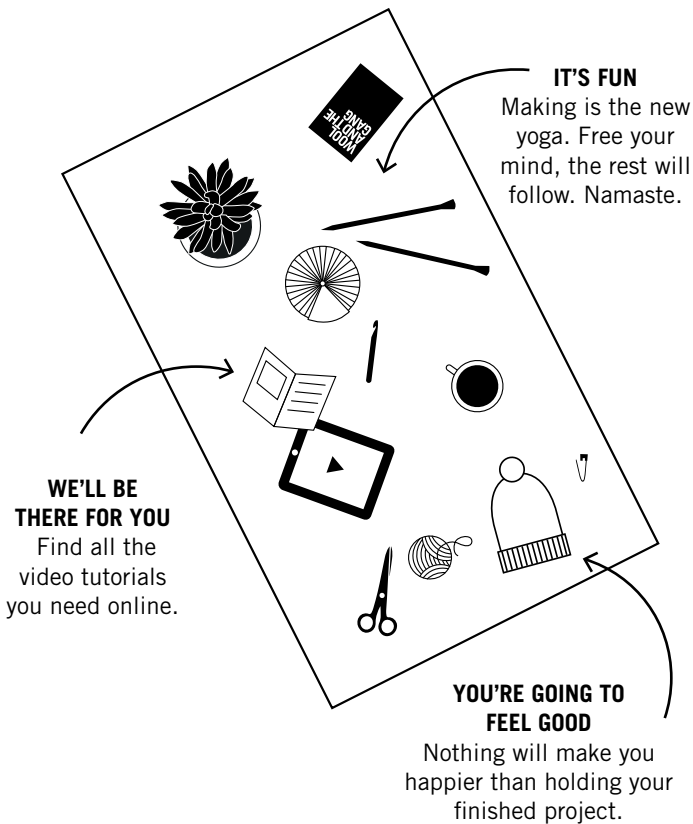

IT'S FUN

Making is the new yoga. Free your mind, the rest will follow. Namaste.

WE'LL BE THERE FOR YOU

Find all the video tutorials you need online.

YOU'RE GOING TO FEEL GOOD

Nothing will make you happier than holding your finished project.

RECIPE FOR SUCCESS

1

GET YOUR TOOLS READY.

Everything you need to get making.

2

FAMILIARISE YOURSELF WITH THE TECHNIQUES.

Everything from the stitches used to the finishing touches for your project.

3

GET TO KNOW YOUR YARN.

Before you start your piece, play around with your new yarn to get used to it, and to check your tension.

4

WOOL SCHOOL

Pick up your hook & yarn and make the magic happen! For a little extra help, check out our Wool School at:

www.woolandthegang.com/t/how-to

5

#WOOLANDTHEGANG

When you're done - let the world know.

LET'S GET MAKING

Tool kit

- 1 roll of WATG's Ra-Ra Raffia in colour A
- 1 roll of WATG's Ra-Ra Raffia in colour B
- 1 roll of WATG's Ra-Ra Raffia in colour C
- 1 Diamond Heart Bag pattern
- 1 4.5mm crochet hook
- 2 wooden handles
- 1 sewing needle

Tension

To ensure your crochet project has the same measurements as the pattern, it is a good idea to make a tension swatch before you start. A tension swatch is a small sample of crochet where you count the stitches and rows and check them against the tension given in the pattern. If you get MORE stitches/rows than the pattern's tension, it means your crochet is TIGHTER. If you get FEWER stitches/rows than the pattern, your crochet is LOOSER. Sometimes, it works to crochet tighter or looser to compensate.

Single crochet

- 10 cm/4" = 16 stitches
- 10 cm/4" = 20 rows

All techniques can be found at the back of the pattern.

Spike stitch

10 cm/4" = 12 stitches

10 cm/4" = 21 rows

Count your stitches and rows as labelled in the photo below.

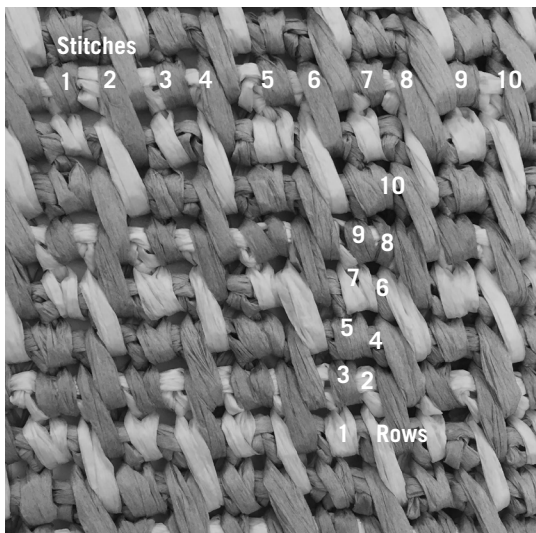

MEASUREMENTS

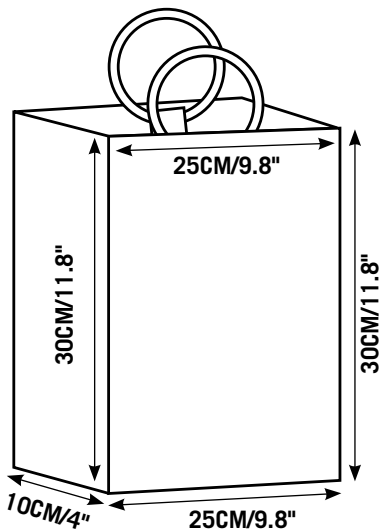

Help's only a stitch away. Watch the video tutorials online at www.woolandthegang.com/t/how-to

Pssst! Remember that you must not copy our patterns and sell, or even give them away for free, in accordance with copyright law.

HOW TO CROCHET YOUR DIAMOND HEART BAG

Your bag is worked in 5 separate panels, a front, a back, 2 sides and a base. You will attach your wooden handles before using the whip stitch to assemble to your bag.

FRONT AND BACK PANEL

Follow the instructions twice to make your front and back panels.

1 Make a foundation chain of 30 stitches using colour A.

2 Chain 1 stitch, (this is your turning chain), work in single crochet across each of the remaining stitches of your foundation chain. (30 stitches.)

3 Chain 1 stitch, work in single crochet to the end of the row.

4 Change to colour B by working 1 chain stitch, you will now work your first row of spike stitches which will be slightly different to the rest of the pattern as you are working into the foundation chain.

★Counting down from where you normally insert your hook (the middle of the stitch underneath both strands of the sideways 'V' at the top) instead, insert your hook into the 3rd hole below (this will be into your foundation chain). Wrap your yarn as usual and bring your hook up to the same level as the row you are working (you will

need a bit of slack in the yarn in your left hand), wrap your yarn again and pull through both loops on the hook. You have made your first long foundation spike stitch.

The next stitch is a variation of this technique. Counting down from where you normally insert your hook instead, insert your hook into the 2nd hole below. Wrap your yarn as usual and bring your hook up to the same level as the row you are working, wrap your yarn again and pull through both loops on the hook. You have made your first short foundation spike stitch★.

Repeat the section inside the stars to the end of the row.

TOP TIP - when changing colours, carry the yarn that you aren't using up the sides (where possible) by twisting it with the colour that you are using at the start of the row. This will save you from having lots of ends to weave in at the end!

5 Chain 1 stitch, work in single crochet to the end of the row.

6 Change to colour C by working 1 chain stitch. Work 1 single crochet stitch. ★Counting down from where you normally insert your hook, instead insert your hook into the 2nd hole below, just to the right of your short foundation spike stitch made 2 rows previously. Wrap your yarn as usual and bring your hook up to the same level as the row you are working, wrap your yarn again and pull through both loops on the hook. You have made

you first short spike stitch.

Counting down from where you normally insert your hook, instead insert your hook into the 4th hole below, just to the right of your long foundation spike stitch made 2 rows previously. Wrap your yarn as usual and bring your hook up to the same level as the row you are working, wrap your yarn again and pull through both loops on the hook. You have made your first long spike stitch★.

Repeat the section inside the stars until you have 1 stitch left of your row, work 1 single crochet stitch.

For the rest of the panel you will work in short and long spike stitches.

-
- 7** Chain 1 stitch, work in single crochet to the end of the row.
-
- 8** Change to colour A by working 1 chain stitch, ★work 1 long spike stitch just to the right of your long spike stitch made 2 rows previously, work 1 short spike stitch just to the right of your short spike stitch made 2 rows previously★. Repeat the section inside the stars to the end of the row.
-
- 9** Chain 1 stitch, work in single crochet to the end of the row.
-
- 10** Change to colour B by working 1 chain stitch. Work 1
-

single crochet stitch, ★work 1 short spike stitch, work 1 long spike stitch★. Repeat the section inside the stars until you have 1 stitch left of your row, work 1 single crochet stitch.

11 Chain 1 stitch, work in single crochet to the end of the row.

12 Change to colour C by working 1 chain stitch, ★work 1 long spike stitch, work 1 short spike stitch★. Repeat the section inside the stars to the end of the row.

13 Chain 1 stitch, work in single crochet to the end of the row.

14 Change to colour A by working 1 chain stitch. Work 1 single crochet stitch, ★work 1 short spike stitch, work 1 long spike stitch★. Repeat the section inside the stars until you have 1 stitch left of your row, work 1 single crochet stitch.

15 Chain 1 stitch, work in single crochet to the end of the row.

16 Change to colour B by working 1 chain stitch, ★work 1 long spike stitch, work 1 short spike stitch★. Repeat the section inside the stars to the end of the row.

17 Chain 1 stitch, work in single crochet to the end of the row.

18 Repeat steps 6 to 17 a further 3 times, your piece should measure approximately 25cm/ 9.8" from the foundation chain.

19 Repeat step 6 to 16 once more.

20 Cut the yarn approx. 15cm/6" from the last stitch. Pull on the loop on your crochet hook until the end pops through - you have now secured the last stitch.

21 Weave in any loose ends.

BASE PANEL

1 For your base panel repeat steps 1 to 17 as for your front and back panel.

2 Repeat steps 6 to 10 once more as for your front and back panel, your piece should measure approximately 10cm/ 4" from the foundation chain.

3 Cut the yarn approx. 15cm/6" from the last stitch. Pull on the loop on your crochet hook until the end pops through - you have now secured the last stitch.

4 Weave in any loose ends.

SIDE PANELS

Follow the instructions twice to make your side panels.

- 1 Make a foundation chain of 36 stitches using colour A.

- 2 Chain 1 stitch, (this is your turning chain), work in single crochet across each of the remaining stitches of your foundation chain. (36 stitches.)

- 3 Chain 1 stitch, work in single crochet to the end of the row.

- 4 Change to colour B by working 1 chain stitch, ★work 1 long foundation spike stitch, work 1 short foundation spike stitch★. Repeat the section inside the stars to the end of the row.

- 5 Chain 1 stitch, work in single crochet to the end of the row.

- 6 Change to colour C by working 1 chain stitch. Work 1 single crochet stitch, ★work 1 short spike stitch, work 1 long spike stitch★. Repeat the section inside the stars until you have 1 stitch left of your row, work 1 single crochet stitch.

- 7 Chain 1 stitch, work in single crochet to the end of the row.

- 8 Change to colour A by working 1 chain stitch, ★work 1

long spike stitch, work 1 short spike stitch★. Repeat the section inside the stars to the end of the row.

9 Chain 1 stitch, work in single crochet to the end of the row.

10 Change to colour B by working 1 chain stitch. Work 1 single crochet stitch, ★work 1 short spike stitch, work 1 long spike stitch★. Repeat the section inside the stars until you have 1 stitch left of your row, work 1 single crochet stitch.

11 Chain 1 stitch, work in single crochet to the end of the row.

12 Change to colour C by working 1 chain stitch, ★work 1 long spike stitch, work 1 short spike stitch★. Repeat the section inside the stars to the end of the row.

13 Chain 1 stitch, work in single crochet to the end of the row.

14 Change to colour A by working 1 chain stitch. Work 1 single crochet stitch, ★work 1 short spike stitch, work 1 long spike stitch★. Repeat the section inside the stars until you have 1 stitch left of your row, work 1 single crochet stitch.

15 Chain 1 stitch, work in single crochet to the end of the row.

16 Change to colour B by working 1 chain stitch, ★work 1

long spike stitch, work 1 short spike stitch★. Repeat the section inside the stars to the end of the row.

17 Chain 1 stitch, work in single crochet to the end of the row.

18 Repeat steps 6 to 10 once more, your piece should measure approximately 10cm/4”.

19 Cut the yarn approx. 15cm/6” from the last stitch. Pull on the loop on your crochet hook until the end pops through - you have now secured the last stitch.

20 Weave in any loose ends.

ASSEMBLY AND FINISHING

Now it's time to make the handle attachments and assemble your bag!

Note: Due to the nature of the single crochet spike stitch you might find your crochet leans to one side, particularly on your bigger front and back panels. To help when assembling your bag, you can pin your pieces in place and steam them so the sides are straight.

First you will attach your handles by making single crochet strap attachments.

- 1 Using colour A make a foundation chain of 8 stitches.

- 2 Work in single crochet until your piece measures 8cm/ 3.1" from the foundation edge.

- 3 Cut the yarn approx. 15cm/6" from the last stitch. Pull on the loop on your crochet hook until the end pops through - you have now secured the last stitch.

- 4 Repeat steps 1 to 3 once more for your second handle attachment.

- 5 Lay your front panel piece flat with the wrong side facing you. Along the top edge, mark 10cm/ 4" from each side towards the centre. Then between these two points measure 5cm/ 2" from the top edge and mark.

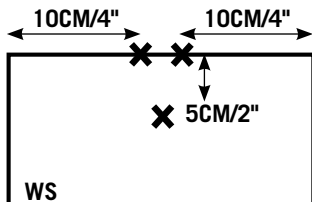

-
- 6 Take your handle attachment and fold in half over your handle, pin the edges together.

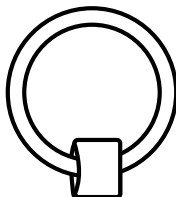

Then place these two edge at the marked point 5cm/ 2" from the top edges of your panel.

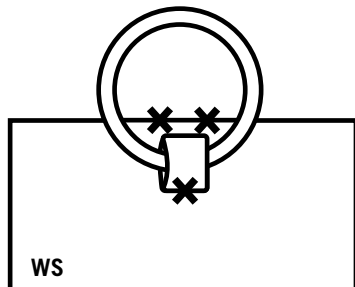

- 7** Thread your needle with a strand of yarn in colour A. Starting under the handle at one side of the attachment, work clockwise around the attachment using the whip stitch technique to attach your handle to the bag. Stop when you reach the handle on the other side.

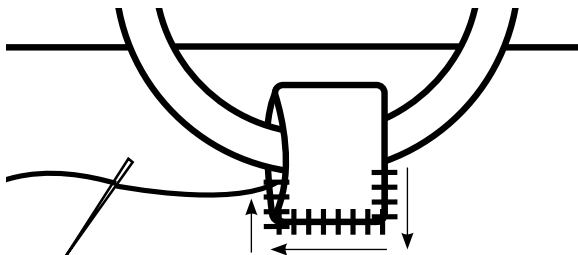

-
- 8** Weave in any loose ends.
-
- 9** Repeat steps 6 to 9 on the back panel piece to attach your other handle.

Note: These instructions attach your handles to the inside of your bag but if you want your handles to be on the outside then simply follow the same steps but work on the right side of your bag!

You will now attach your panels together.

-
- 10** Lay your pieces flat with the right sides facing you. Thread your needle with a long strand of colour B
-

and use the whip stitch technique to sew your pieces together as follows:

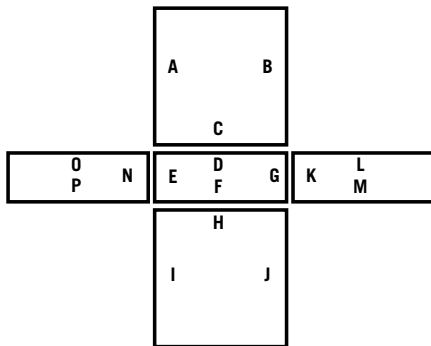

Attach side C to D.
Attach side F to H.
Attach side G to K.
Attach side E to N.
Attach side B to L.
Attach side M to J.
Attach side I to P.
Attach side O to A.

-
- 11** You will now add a decorative slip stitch edging around the top of your basket.

Starting in the top corner where you have joined sides B and L, using colour B work in slip stitch along the edge of your panels. Work 30 stitches along each long edge and 12 stitches along each short edge. Join your round

with a slip stitch into the first stitch made in the step.
(84 stitches.)

12 Weave in any loose ends.

CROCHET TECHNIQUES



Help's only a stitch away. Watch the video tutorials online at www.woolandthegang.com/t/how-to

Crochet hook

The crochet hook is your tool on the path to greatness! Your pattern may refer to different parts of the crochet hook - here is an illustration to help you understand it all a little better.

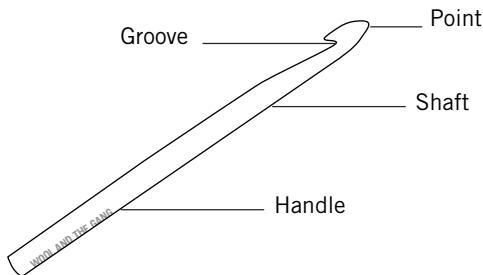

Turning Chains

When working in crochet, you often need to do a 'turning chain' at the beginning of your row. This creates a stitch that 'lifts' you up to the next level, so you're ready to crochet the next row. The turning chain is made up of chain stitches, and the number of stitches varies between different types of stitches. (Your pattern will tell you how many stitches to use for the stitch you're working in.)

Chain stitch / [▶ Online video tutorial](#)

This is the foundation of most crochet work and can also be used as a technique on its own.

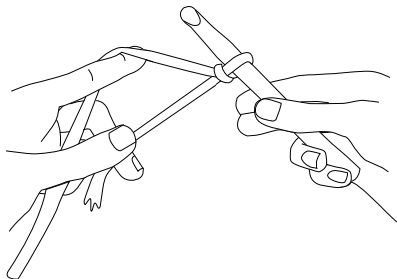

- 1 Make a slipknot and place it on the shaft of your crochet hook. Hold the hook in your right hand and the yarn in your left hand.

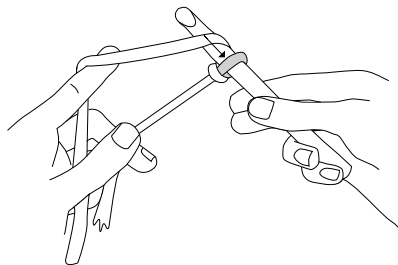

- 2 Move the point of the crochet hook UNDER the yarn from left to right, then move it OVER the yarn from right to left. The yarn is now looped around your crochet hook.

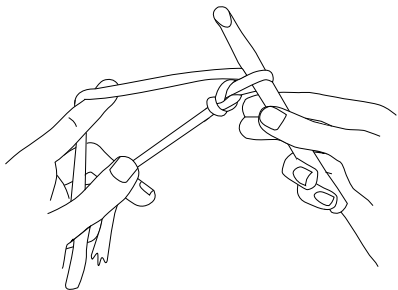

- 3** Scoop up the yarn with the groove of the hook, and pull it through the loop already on your hook. Slide the new stitch towards the shaft of the hook. You've now made one chain stitch.

Repeat steps 2 and 3 to keep creating new stitches. Take care not to pull your stitches too tightly! When counting your stitches, count each of the loops except the one on your hook.

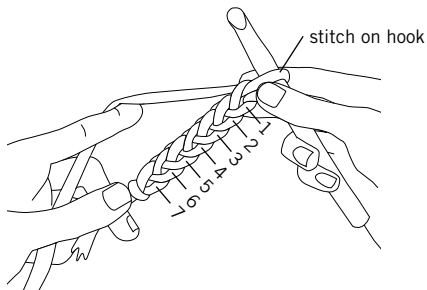

To make a chain stitch in the main body of your piece (for example, to make a turning chain), repeat steps 2 and 3.

Single crochet / [▶ Online video tutorial](#)

This stitch is one of the most basic crochet stitches. It uses a turning chain of 1 stitch.

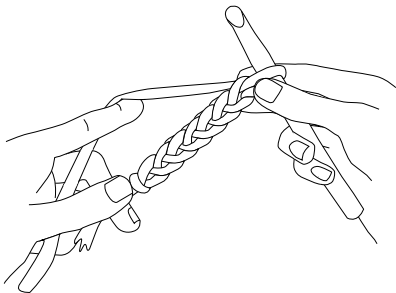

To work into a foundation chain at the beginning of your work, start with your hook in your right hand and the work in the left. Work across your foundation chain from right to left.

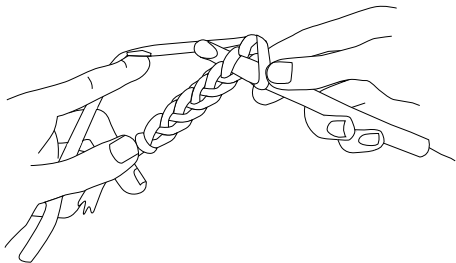

- 1 Insert your crochet hook into the middle of the second stitch from the hook (not counting the stitch on the hook!).

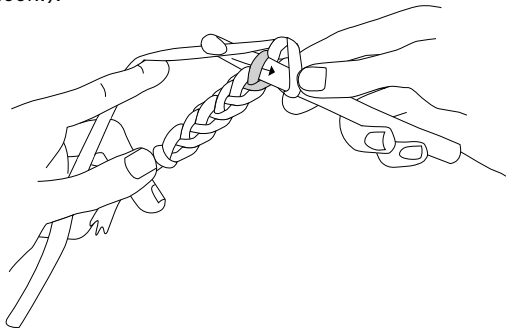

- 2 Move the hook under and then over the yarn. Scoop the yarn with the groove of your hook, and pull it through the stitch. There are now two loops on your hook.

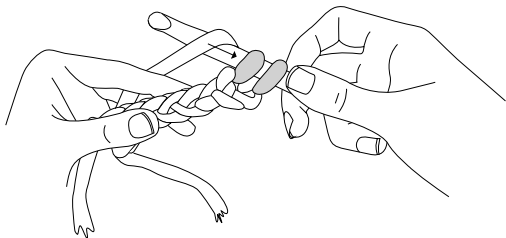

- 3 Loop the yarn around the hook again, and pull the yarn through BOTH of the loops on your hook. You have now worked one stitch in single crochet, and there's a single

stitch on your hook again.

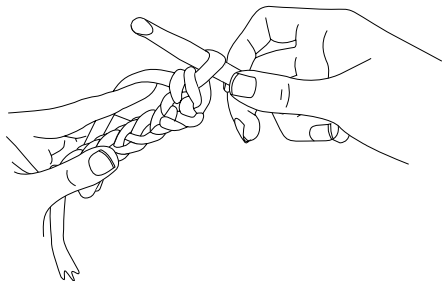

- 4 To continue working in single crochet, insert the hook into the next stitch of your row and repeat steps 2 and 3.

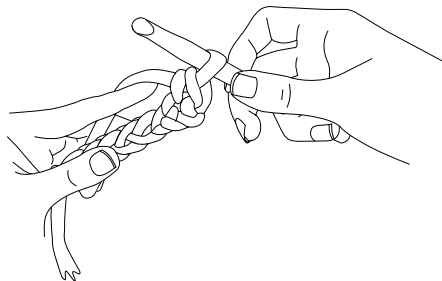

To work into a stitch that was crocheted on the previous row, insert your crochet hook underneath **both strands** of the sideways 'V' at the top of the next stitch, then repeat steps 2 and 3.

Spike stitch / [▶ Online video tutorial](#)

The spike stitch is a variation of single crochet and looks really effective when worked in a stripe, but can also be worked in one colour. This stitch is worked over multiples of 2 stitches.

These instructions show you how to work a short spike stitch and a long spike stitch, these can be used in variations, for example you can work a row of just short stitches or just long stitches, or mix them together.

- 1 Work 2 rows of single crochet.
- 2 You will now make your first long foundation spike stitch. Chain 1 stitch, counting down from where you normally insert your hook (the middle of the stitch underneath both strands of the sideways's 'V' at the top) instead, insert your hook into the 3rd hole below (this will be into your foundation chain).

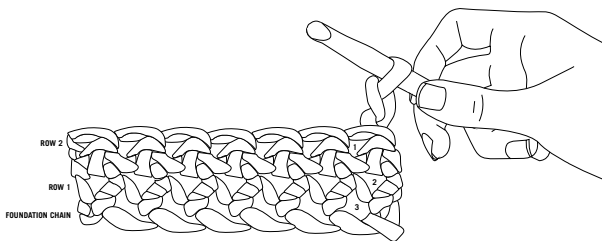

Wrap your yarn as usual and bring your hook up to the same level as the row you are working (will need a bit of slack in the yarn in your left hand), wrap your yarn again and pull through both loops on the hook.

- 3** You will now make your first short foundation spike stitch. Counting down from where you normally insert your hook, instead insert your hook into the 2nd hole below (this will be into row 1).

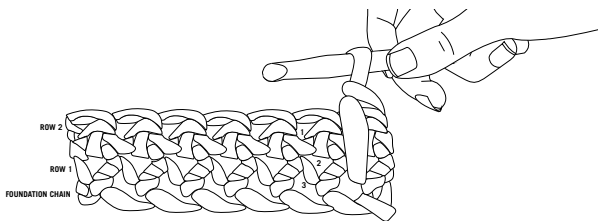

Wrap your yarn as usual and bring your hook up to the same level as the row you are working, wrap your yarn again and pull through both loops on the hook.

- 4** Continue alternating between long foundation spike stitches and short foundation spike stitches until you reach the end of your row.

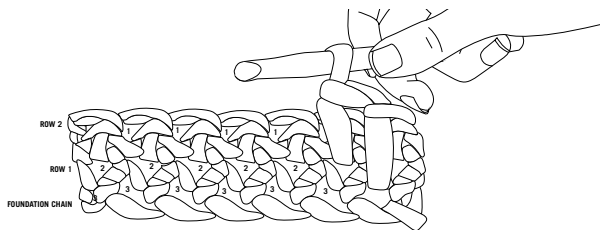

- 5** Chain 1 stitch, work 1 row of single crochet.

- 6** You will now make your first long spike stitch. Chain 1 stitch, counting down from where you normally insert your hook instead, insert your hook into the 4th hole below, just to the right of your long foundation spike stitch made 2 rows previously. Wrap your yarn as usual and bring your hook up to the same level as the row you are working, wrap your yarn again and pull through both loops on the hook.

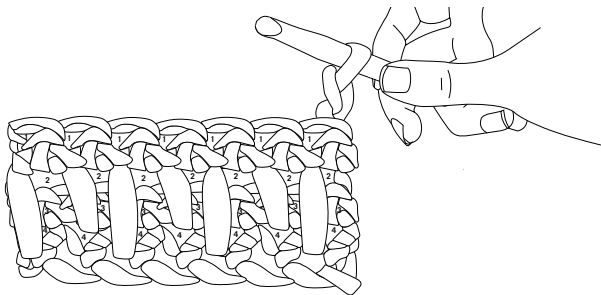

- 7** You will now make your first short spike stitch. Counting down from where you normally insert your hook instead, insert your hook into the 2nd hole below, just to the right of short foundation spike stitch made 2 rows previously. Wrap your yarn as usual and bring your hook up to the same level as the row you are working, wrap your yarn again and pull through both loops on the hook.

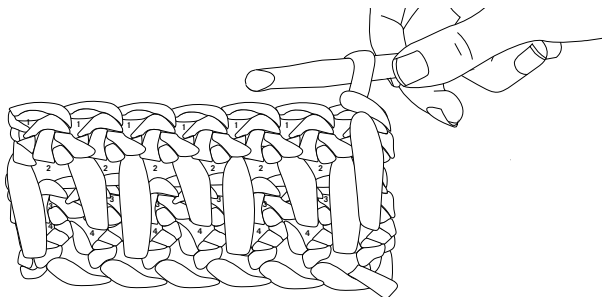

- 8** Continue alternating between long spike stitches and short spike stitches until you reach the end of your row.

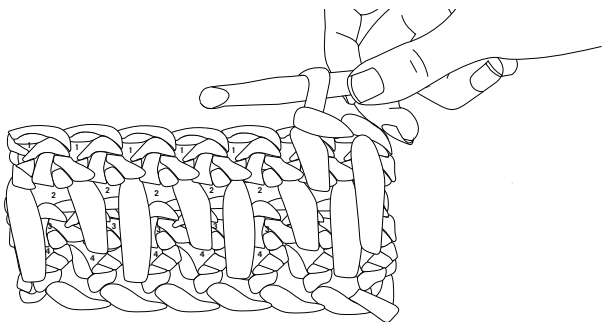

- 9** Repeat steps 5 to 8 until your piece is the desired length.

Working with stripes / [▶ Online video tutorial](#)

When working with stripes, there is no need to cut the yarn every time you change colour. Instead, you simply carry the yarn up the edge of your crochet (when possible) - this way you won't have a ton of yarn ends to sew in at the end! To avoid long loops at the edges where the yarn is carried, you twist your yarns together.

To change colour at the beginning of your row, make 1 chain stitch (this is your turning chain) using the colour you are changing to and continue to work your row using the new colour.

Slip stitch / [▶ Online video tutorial](#)

Insert your crochet hook into the next stitch. Starting with the hook in front of the yarn, move the hook under and then over the yarn, so the yarn ends up looped around the shaft of the hook. Scoop up the yarn with the groove of your hook and pull it through both the stitch and the loop on your hook. You now have a single loop on your hook. You have worked one slip stitch.

FINISHING TECHNIQUES

Whip Stitch

This is a simple way of joining two pieces of crochet.

- 1 Place the two crocheted pieces together with the right sides facing you.
- 2 Thread your sewing needle with a strand of yarn, and secure it to the wrong side of the fabric.
- 3 Insert your sewing needle through the first stitch of your row and, working from the inside of your piece to the outside, pull the yarn through your first piece.
- 4 Insert your sewing needle into the next stitch in your second piece of fabric, and push it back from outside to inside. Pull the yarn through.
- 5 Move back to your first piece and work from inside to outside once more.

Continue in this way until your seam is done.

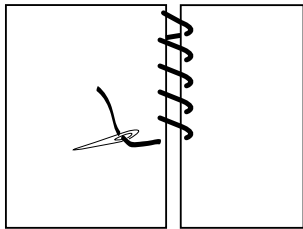

Hiding your yarn ends / [▶ Online video tutorial](#)

To hide the tail of your yarn, turn your work so the wrong side is facing you. Thread your sewing needle with the yarn end, and sew horizontally across your work, inserting needle and yarn underneath the back two strands of your crocheted stitches. Work like this for a few stitches, then move down a row and work back in the opposite direction. Finally, cut the yarn close to the fabric.

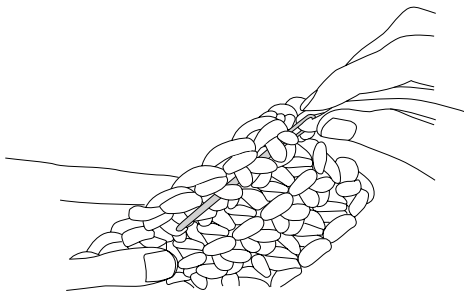

MAKING MEMOIRS

STARTED ON

FINISHED ON

WHERE I MADE IT

-

-

-

MADE FOR

Me

COLOUR COMBO

.....

THIS PROJECT WAS

() easy peasy () nice () challenging () hardcore

I FEEL    

OTHER THOUGHTS

NOTES

1"

2"

3"

4"

5"

5 CM

10 CM



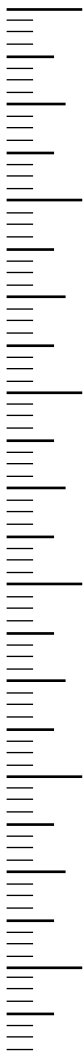

1"

2"

3"

4"

5"



5 CM

10 CM





Wool and the Gang



@woolandthegang



@woolandthegang



WATGsnaps



Wool and the Gang



woolandtheganghq

YOUR PROJECT DESERVES SOME SEXY YARN

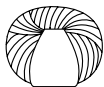

CRAZY SEXY WOOL

100% Peruvian Wool

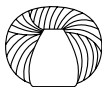

HEAL THE WOOL

100% Recycled Wool



LIL' HEAL THE WOOL

100% Recycled Wool



JERSEY BE GOOD

98% Cotton
2% Elastane



MIXTAPE YARN

80% Cotton
20% Polyester



BILLIE JEAN

100% Upcycled Denim



TAKE CARE MOHAIR

78% Kid Mohair
13% Wool / 9% Polyamide



FEELING GOOD

70% Baby Alpaca
7% Merino / 23% Nylon



SHINY HAPPY COTTON

100% Peruvian
Pima Cotton



SUGAR BABY ALPACA

100% Baby Alpaca



TINA TAPE YARN

100% Tencel®

WWW.WOOLANDTHEGANG.COM

**WOOL
AND THE
GANG**

V763143504

