

WOOL AND THE GANG

#MADEUNIQUE

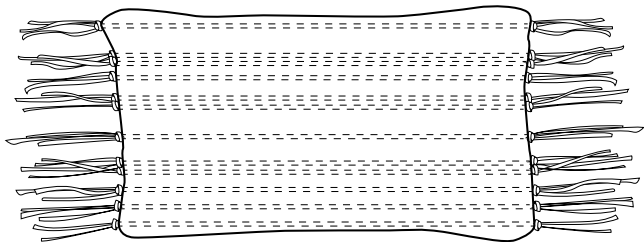

ACHY BREAKY CUSHION

EASY

5MM (8US) NEEDLES

© Wool and the Gang LTD. 2019

YOUR ADVENTURE STARTS NOW



IT'S FUN
MAKING is the
new yoga. Free
your mind, the
rest will follow.
Namaste.

**WE'LL BE
THERE FOR YOU**
Find all the
video tutorials
you need online.

**YOU'RE GOING TO
FEEL GOOD**
Nothing will make you
happier than holding your
finished project.

RECIPE FOR SUCCESS

1

GET YOUR TOOLS READY.

Everything you need to get knitting.

2

FAMILIARISE YOURSELF WITH THE TECHNIQUES.

Everything from the stitches used to the finishing touches for your project.

3

GET TO KNOW YOUR YARN.

Before you start knitting your piece, play around with your new yarn to get used to it, and to check your tension.

4

WOOL SCHOOL

Pick up your needles & yarn and make the magic happen! For a little extra help, check out our Wool School at:

www.woolandthegang.com/videos

5

#SHAREYOURKNITS

When you're done - let the world know.

LET'S GET KNITTING

Tool kit

- 3 balls of WATG's Shiny Happy Cotton in colour A
- 1 ball of WATG's Shiny Happy Cotton in colour B
- 1 ball of WATG's Shiny Happy Cotton in colour C
- 1 ball of WATG's Shiny Happy Cotton in colour D
- 1 ball of WATG's Shiny Happy Cotton in colour E
- 1 Achy Breaky Cushion pattern
- 1 pair of 5mm (8US) knitting needles
- 1 sewing needle

You will also need an inner cushion (not included)
30cm/11.5" x 50cm/19.5"

Tension

To ensure your knitting has the same measurements as the pattern, it is a good idea to make a tension swatch before you start knitting your project. A tension swatch is a small sample of your knitting where you count the stitches and rows and check them against the tension given in the pattern. If you get MORE stitches/rows than the pattern's tension, it means your knitting is tighter. If you get FEWER stitches/rows than the pattern, your knitting is looser. Sometimes, it works to knit tighter or looser to compensate.

Reverse stocking stitch

10 cm/4" = 17 stitches

10 cm/4" = 23 rows

All knitting techniques can be found at the back of the pattern.

MEASUREMENTS

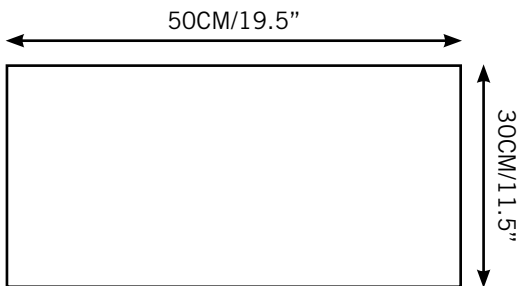

Pssst! Remember that you must not copy our patterns and sell, or even give them away for free, in accordance with copyright law.

HOW TO KNIT YOUR ACHY BREAKY CUSHION

Your cushion is knitted in one long rectangle and is then folded inwards on assembly to create an envelope opening at the back. You will then weave yarn through, after assembly, to create the stripe pattern.

- 1 Using colour A cast on 52 stitches using the cable cast on technique.

- 2 Starting with a right side row (purl row), work in reverse stocking stitch until your piece measures 110cm/43.3" from the cast on edge. (Approx. 253 rows.)

- 3 Cast off.

ASSEMBLY AND FINISHING

- 1 Place your knitted piece flat and horizontal with the wrong side facing you. Make a fold 30cm/11.8" from one of the short edges (the wrong sides of the fabric will be touching). Thread your needle with a length of yarn in colour A and sew the side edges together using the vertical invisible seam technique.

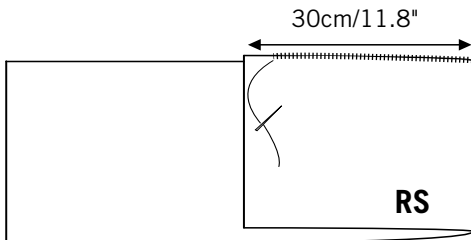

-
- 2 Now make a fold 30cm/11.8" from the second short edge, so it overlaps the first fold by 10cm/3.9". Sew the side edges together using the vertical invisible seam technique. At the point where the two layers overlap, continue using the vertical invisible seam technique but instead of joining the two edges you will be joining the overlap edge to the seam of the cushion underneath. You will be going under the horizontal bar at the edge of the top layer, and under the horizontal bar closest to the seam on the bottom layer.

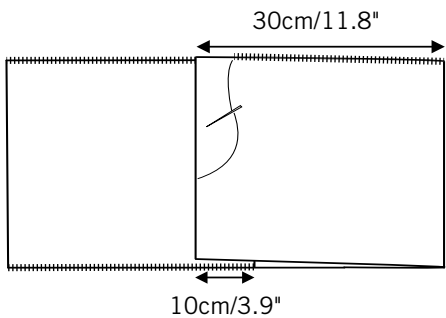

3 Weave in any loose ends.

WEAVING THROUGH REVERSE STOCKING STITCH

The right (purl) side of reverse stocking stitch looks like a series of curved horizontal bars - half are the actual stitches (these look a little like 'n's), and the rest are formed when the yarn is carried between stitches (these look like 'u's).

To create the stripe weave pattern, you will be weaving upwards through the actual stitches ('n's) and then in between each stitch where the yarn is carried between stitches ('u's). In the weave pattern both these 'n's and 'u's will be referred to as columns. For example when you are instructed to 'weave 2 columns in colour B' you will be weaving once upwards through the actual stitches ('n's) and then once upwards in between each stitch where the yarn is carried between stitches ('u's).

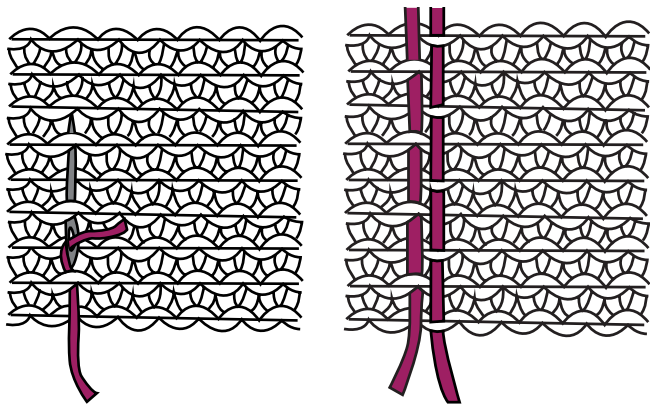

Weaving Technique

Cut the following strands of yarn ready to weave;

- Cut 16 strands of yarn measuring 160cm/62.9" in colour B.
- Cut 10 strands of yarn measuring 160cm/62.9" in colour C.
- Cut 12 strands of yarn measuring 160cm/62.9" in colour D.
- Cut 10 strands of yarn measuring 160cm/62.9" in colour E.

Fold each strand in half, you will now have 48 double ply lengths of yarn measuring 80cm/31.4", one end will have 2 loose ends, the other end will have a folded end.

To weave through the cushion, thread your sewing needle with a double ply strand. Thread your needle through your first stitch ('n') in one column, leaving a 15cm/5.9" tail of yarn at the beginning. Next, alternately weave the yarn under and over the little horizontal bars along one vertical column for 50cm/19.5", leaving 15cm/5.9" of yarn at the end of your cushion.

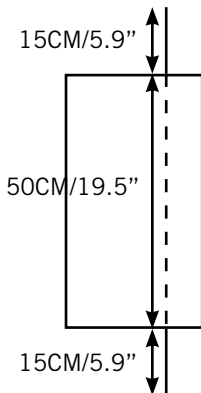

Take your next strand, starting one column to the right (through the 'u's). Again, alternately weave the yarn under and over the little horizontal bars of the column for 50cm/19.5".

TOP TIP: Don't pull your strands too tight when weaving them through, as this will alter the shape of your cushion!

Place your assembled cushion down vertically with the front of the cushion facing you. Starting at the bottom left of your cushion, follow the following pattern for the stripe pattern.

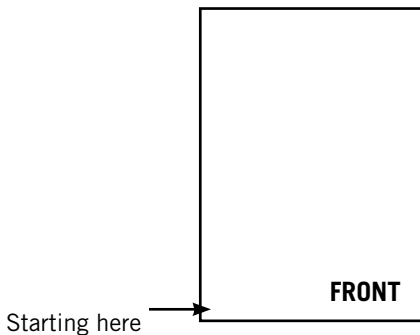

- 1 Skip 4 columns.

- 2 Weave 4 columns in colour B.

- 3 Skip 2 columns.

- 4 Weave 2 columns in colour C.

- 5** Skip 4 columns.
-
- 6** Weave 4 columns in colour D.
-
- 7** Weave 2 columns in colour B.
-
- 8** Skip 2 columns.
-
- 9** Weave 2 columns in colour E.
-
- 10** Skip 6 columns.
-
- 11** Weave 2 columns in colour C.
-
- 12** Weave 2 columns in colour B.
-
- 13** Skip 4 columns.
-
- 14** Weave 2 columns in colour D.
-
- 15** Skip 2 columns.
-
- 16** Weave 4 columns in colour E.
-
- 17** Skip 2 columns.
-
- 18** Weave 2 columns in colour B.
-
- 19** Skip 6 columns.
-
- 20** Weave 2 columns in colour C.
-

- 21** Weave 2 columns in colour D.
-
- 22** Skip 2 columns.
-
- 23** Weave 2 columns in colour E.
-
- 24** Skip 4 columns.
-
- 25** Weave 4 columns in colour B.
-
- 26** Weave 2 columns in colour D.
-
- 27** Skip 6 columns.
-
- 28** Weave 4 columns in colour C.
-
- 29** Skip 2 columns.
-
- 30** Weave 2 columns in colour E.
-
- 31** Weave 2 columns in colour B.
-
- 32** Skip 2 columns.
-
- 33** Weave 2 columns in colour D.
-
- 34** Skip 4 columns.

To finish, group your ends into groups of 4 threads and make an overhand knot then trim the yarn ends to 10cm/3.9”.

KNITTING TECHNIQUES

Work! Work! Work!

There are two main ways to 'work' stitches: they can be knitted or purled. When the pattern asks you to 'work' a number of stitches/rows/cm, it will always specify which stitch pattern to work in.

Cable cast on / [Online video tutorial](#)

- 1 Create a slipknot on the left needle. Insert the right needle knit-wise into the slipknot. Wrap the yarn around the needle clockwise.
- 2 Scoop the right needle forwards.
- 3 You now have a stitch on the right needle - pull on the stitch to make it a little larger.
- 4 Slip the stitch onto the left needle. (You now have 2 stitches.)
- 5 To cast on your next stitch, insert the right needle **between** the 2 stitches, then repeat steps 2 to 4.

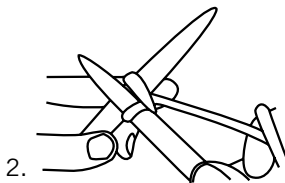
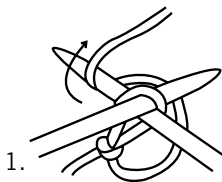

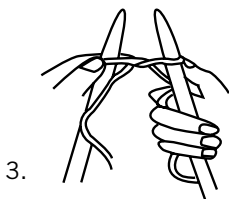

Reverse stocking stitch

A basic stitch pattern where all the stitches of the first row (right side) are purled, and on the second row they are knitted. These two rows are repeated to make the pattern.

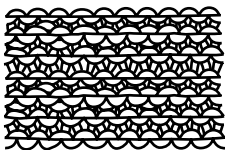

Adding a new ball of yarn / [▶ Online video tutorial](#)

When your ball of yarn runs out, or when you need to change the colour, tie a loose knot on to the tail with the new ball of yarn and slide it up to the needle. Tighten the knot. Continue knitting with the new yarn.

Casting off / [▶ Online video tutorial](#)

When you complete your project, you need to cast off your last row of stitches in order to make an edge that won't unravel. For your final row, knit the first two stitches. Using the tip of the left needle, lift the first stitch up and over the second stitch and then slip it off the right needle. Now you

have only one stitch on your right needle. Knit the next stitch from the left needle, then lift the previous stitch over it and off the needle as before. Do this with each stitch until there are no stitches on the left needle and just one stitch on the right needle. Cut the yarn, leaving a 15cm/6" end. With your fingers, gently pull the tail through the last stitch and pull the yarn tight to secure.

FINISHING TECHNIQUES

Vertical invisible seam / [▶ Online video tutorial](#)

This technique is used to join the side edges of two pieces. Place the two knitted pieces side by side with the right sides up.

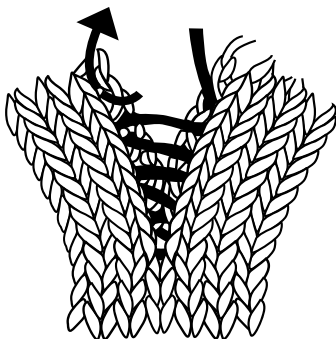

Pull the yarn through and insert the needle through the opposite horizontal bar on the other piece. Sew back and forth through the horizontal bars along the edge. To tighten the stitches, pull the yarn gently - and they will disappear.

Weaving in the ends / [▶ Online video tutorial](#)

Weave the ends of your yarn into your knitting to finish it off and stop it from unravelling. Thread the tail onto the sewing needle. Weave the yarn along the edge of your knitting as shown in the diagram. Weave in approximately 10 cm/4", then cut the tail.

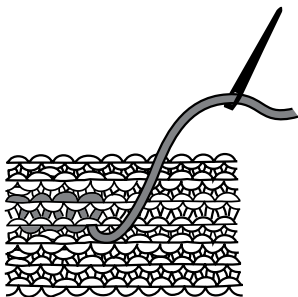

OVERHAND KNOT

- 1 Start by making a loop where you want your knot to be. Cross the working end in front of the tail end.
- 2 Now take the working end through the back of the loop and pull the two ends away from each other to tighten the knot.

TAIL END

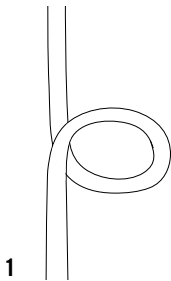

1

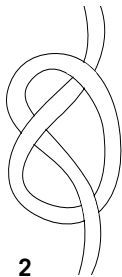

2

WORKING END

MAKING MEMOIRS

STARTED ON

FINISHED ON

WHERE I MADE IT

-

-

-

MADE FOR

Me

COLOUR COMBO

.....

THIS PROJECT WAS

() easy peasy () nice () challenging () hardcore

I FEEL    

OTHER THOUGHTS

.....

NOTES

1"

2"

3"

4"

5"

Handwriting practice lines consisting of 20 horizontal dotted lines.

5 CM

10 CM

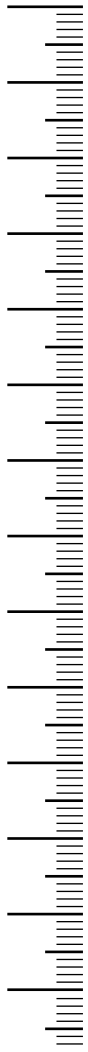



Wool and the Gang



@woolandthegang



@woolandthegang



WATGsnaps



Wool and the Gang



woolandtheganghq

YOUR PROJECT DESERVES SOME SEXY YARN



CRAZY SEXY WOOL
100% Peruvian Wool



SUGAR BABY ALPACA
100% Baby Alpaca



WOOL ME TENDER
100% Peruvian Wool



JERSEY BE GOOD
98% Cotton
2% Elastane



MIXTAPE YARN
80% Cotton
20% Polyester



BILLIE JEAN
100% Upcycled Denim



SHINY HAPPY COTTON
100% Peruvian
Pima Cotton



WOOLY BULLY ALPACA
80% Superfine Alpaca
20% Merino Wool



SHEEPACA YARN
50% Baby Alpaca
50% Merino Wool



TAKE CARE MOHAIR
78% Kid Mohair
13% Wool / 9% Polyamide



FEELING GOOD
70% Baby Alpaca
7% Merino / 23% Nylon

**WOOL
AND THE
GANG**

V381157342

