



MeacoClean CA-HEPA 76x5 Wifi Instruction Manual



MeacoClean CA-HEPA 76x5 Wifi

Please read this instruction manual before using the air purifier and keep safe for future reference.

Thank you for choosing Meaco, we really appreciate it.

SAFETY INFORMATION

This portable air conditioner must not be used in rooms under the following conditions:

- *Potentially explosive atmosphere*
- *Aggressive atmospheres*
- *Featuring a high concentration of solvents*
- *An extremely high ratio of dust*



Keep Children Away: Do not allow children to play with or around this unit, which could result in injury. Be sure the unit is inaccessible to children when not attended. This appliance is not intended for use by person (including children) with reduced physical, sensory or mental capabilities, or lack of experience and knowledge, unless they have been given supervision or instruction concerning use of the appliance by a person responsible for their safety.

Keep Unit Grounded: Always operate the unit with a grounded plug and a grounded electrical outlet. A grounded plug is an essential safety feature that helps reduce the risk of shock or fire.

Protect Power Cord from Damage: Never operate a unit with a damaged power cord, as this may lead to electrical or fire hazards. If the power supply cord is damaged, it must be replaced by a cord of the same type and amperage rating.

Extension Cords: Extension cords must be grounded and able to deliver the appropriate voltages to the unit.

External Timers: Never operate the air purifier with an external timer. Doing so could damage the internal components and will decrease the lifespan of the product. Using the unit with an external timer will invalidate the warranty.

Handle with Care: Do not drop, throw or crash the air purifier. Rough treatment can damage the components or wiring and create a hazardous condition.

Run on Stable Surface: Always operate the unit on a stable, level surface, for example the floor or a strong counter, so that the air purifier cannot fall and cause injury.

Keep Out of Water: Never operate the unit in pooled or standing water, as this may create a risk of injury from electrical shock. Do not store or operate outdoors. If electrical wiring or components become wet, thoroughly dry them before using the unit. If in doubt do not use the air purifier and consult a qualified electrician or a Meaco approved engineer.

Keep Electrical Components Dry: Never allow water inside the air purifier's electrical components. If these areas become wet for any reason, thoroughly dry them before using the air purifier. If in doubt, do not use the air purifier and consult a qualified electrician or a Meaco approved engineer.

Keep Air Intakes Clear: Do not clog or block the air intakes by placing the air purifier too close to curtains, walls or anything that will restrict the air inlet. This may cause the unit to overheat and result in a fire or electrical hazard.

Keep Filter Clean or Replace: Always use a clean air filter. Do not allow any material to clog the filter as this may cause the air purifier to overheat. Never use without a filter, if the filter is blocked then it is time to buy a replacement filter set. Always check, and if necessary, clean or replace the filter before switching the air purifier on. Do not allow oil, grease, or other contaminants to be drawn into the air purifier. Do not clean the air purifier with organic solvents.

A Clean Filter is Important: Check the filter regularly in order to keep it clean as per the instructions in this manual. A dirty filter will restrict the air flow into the machine which will increase the resistance on the fan and could result in damage and might invalidate the warranty. The power light will flicker when the filters have come to the end of their natural life.

Turning Off: Never unplug the power cord without press the "Power" key to off first, as this could damage the unit. Always unplug the unit when not in use or moving location. To disconnect from the power supply, grip the plug and pull from the power socket. Never pull by the cord.

Repairs: To repair the unit, take it to a qualified service engineer. Repairs carried out by unqualified people may cause damage to the unit or injury to persons or property and void the warranty.

The operator must make the operating instruction available for the user and make sure that the user does understand the manual.

WIRING INSTRUCTIONS

Should it be necessary to change the plug, please note the wires in the mains lead are coloured in accordance with the following code:

BLUE – NEUTRAL
 BROWN – LIVE
 GREEN AND YELLOW – EARTH

As the colours of the wires in the mains lead of this appliance may not correspond with the coloured markings identifying the terminals in your plug, proceed as follows:

1. The **BLUE** wire is the NEUTRAL and must be connected to the terminal which is marked with the letter N or coloured **BLACK**.
2. The **BROWN** wire is the LIVE and must be connected to the terminal which is marked with the letter L or coloured **RED**.
3. The **GREEN/YELLOW** is the EARTH and must be connected to the terminal which is marked with the letter E or coloured **GREEN** or **GREEN/YELLOW**.
4. Always ensure that the cord grip is positioned and fastened correctly.
5. Only ever use the same fuse as fitted in the original product, if in doubt please contact Meaco first, or a qualified electrician.

Example wiring for a Standard British Plug:

Please note: The Earth Terminal is marked with the letter E or Earth Symbol .

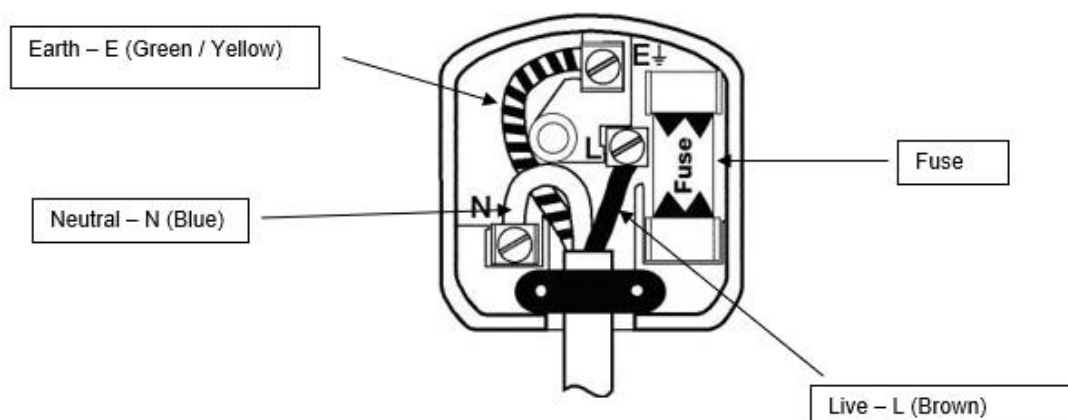

GENERAL ADVICE

- Before putting your air purifier into operation for the first time, the instruction manual should be studied carefully.
- After receiving the air purifier, you should check the unit for any transport damage. In case of damage, you should inform the sender immediately.
- Keep the packaging for the air purifier in a safe place in order to be able to despatch the unit safely if it requires a service. In order to save space, you can simply cut through the adhesive tape using a knife and fold the cardboard box.

GENERAL PRINCIPLES

This air purifier uses a multi-stage air cleaning system. The room air first moves across the pre-filter to remove larger particles such as dust from the air. The HEPA filter then removes smaller allergens from the air and finally the charcoal filter removes any smells from the air. The ioniser helps to remove extra dust particles from the air.

The more times that the air within the room passes through the air purifier the cleaner the air will become. This is why it is important to carefully size the air purifier to your room size. Look for a minimum of three air changes per hour through the air purifier, we use five air changes per hour as a guide when sizing the machine up.

PRODUCT IDENTIFICATION

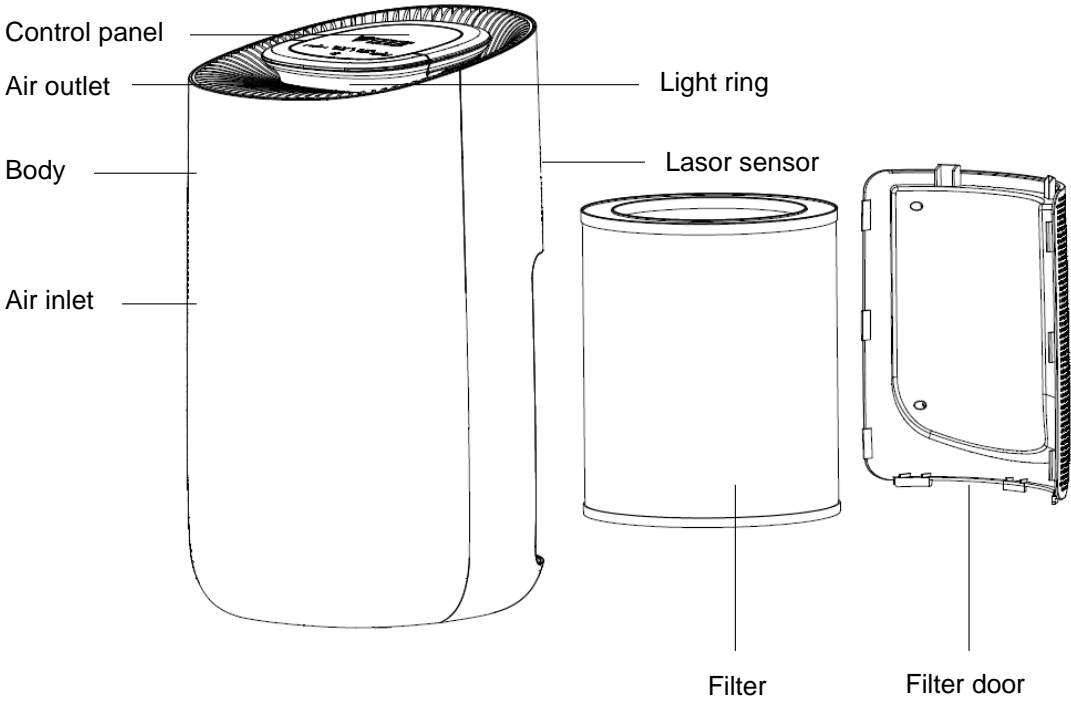

INSTALLATION

- Position the air purifier on a firm, flat, horizontal surface.
- Leave at least 30cm of space around the air purifier and 50cm of space above the air purifier when in use.
- Do not allow any objects or water to drop into or be inserted into the air purifier.
- Remove packaging from the filter before use, see diagrams below. Make sure the air purifier is unplugged before removing the filter cover.

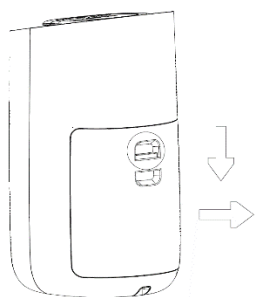

1. Open the filter door by squeezing the button on the door to release.

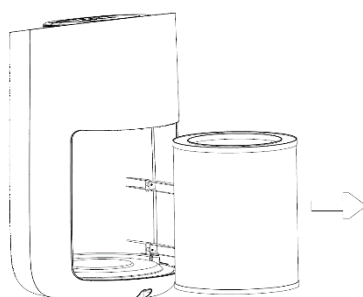

2. Push the filter down and twist it clockwise to remove.

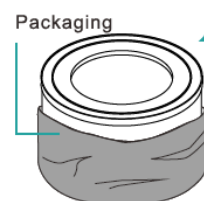

3. Remove the filter from its packaging.

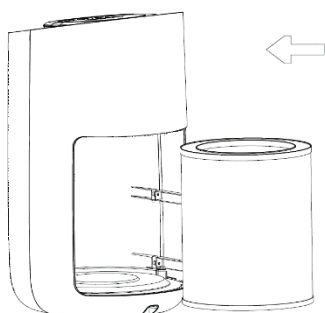

4. Re-insert filter.

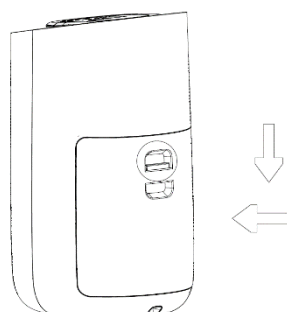

5. Put the filter door back in place – squeeze the button on the door to reinsert.



6. Tap and hold the filter button on the display for 7 seconds.

CONTROL PANEL

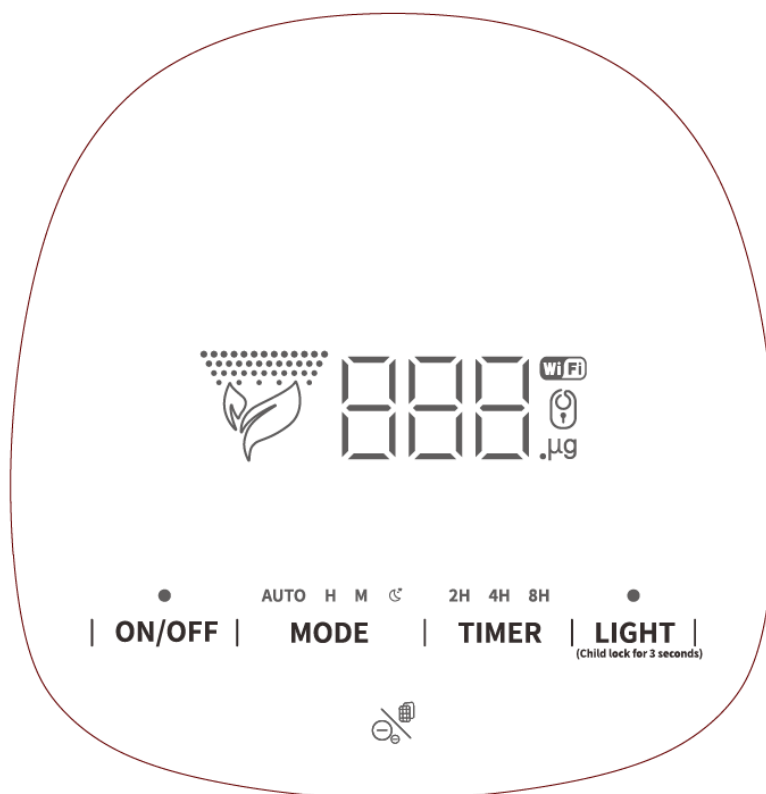

When plugged in all LED indicators will display for one second and then turn off – the air purifier is in standby mode. The display is touch screen, press the buttons quickly and firmly unless instructed otherwise.

● ON/OFF

Power button

Press the power button once to turn the air purifier on – it will run in default mode. The LED lights will change colour for 20 seconds in the following order:

blue – cyan – green – yellow – orange – red – purple

After 20 seconds the light will stay solid. The chosen light colour is dependent on the air quality. Blue indicates good air quality, yellow indicates average air quality and purple indicates poor air quality. The digital display will show the PM_{2.5} number of the air.

Press the power button again to turn the air purifier off – all the LED indicators will turn off and the air purifier will be in standby mode.



PM_{2.5} reading

PM_{2.5} means the mass per cubic metre of air of particles with a size (diameter) generally less than 2.5 micrometres (µm). The air purifier has a laser sensor which measures the concentration of dust particles in the air. This is then shown on the display as a PM_{2.5} particle reading – effectively showing how clean the air is.

0-75µm means the air quality is good, 76-150µm means the air quality is normal and 150+ µm means the air quality is bad. The light ring will change colour in correspondence to these levels.

AUTO H M 

Mode button

MODE

Press the mode button to move through the four modes: Auto, High, Medium and Sleep. The corresponding symbol will light up on the display.

1. Auto Mode: The fan speed will automatically adjust according to the air quality.

2. High Mode: The air purifier will run on the highest fan speed.

3. Medium Mode: The air purifier will run on the middle fan speed.

4. Sleep Mode: In sleep mode all lights on the display will turn off after five seconds. The power light and sleep mode icon will remain on but dim. The air purifier will run on the lowest fan speed. The lights on the display will turn on when any button is pressed. To remove sleep mode, press the mode button and change the mode to Auto, High or Medium.

2H 4H 8H

Timer/Wi-Fi button

TIMER

Press the timer button to set an 'off timer' for either 2, 4 or 8 hours. The chosen number of hours will light up on the display. Once the chosen time is up, the air purifier will stop working and all lights on the display (except the Wi-Fi light) will turn off – the air purifier will be in standby mode. See page 9 for more information on the Wi-fi options.



Light/Child Lock button

LIGHT

(Child lock for 3 seconds)

Press the light button to adjust the brightness of the coloured light between soft, standard and off mode. The light button cannot be operated during the first 20 seconds of the air purifier turning on. If you want to turn all the lights on the display off, put the air purifier into sleep mode (see above).

Hold the light button down for three seconds to turn child lock on. The air purifier will beep once and a lock symbol will appear on the display. When child lock is on all functions are disabled. To turn child lock off hold the light button down for three seconds. The air purifier will beep once and the lock symbol will disappear.



Ioniser/Filter button

Press the ionizer button once to turn the ioniser on, press it again to turn the ioniser off. The button will beep every time it is pressed. The ioniser/filter button cannot be seen unless it is pressed. See page 7 for its location on the display.

Once the air purifier has reached 2200 hours of usage, or detects that the filter needs changing, the ioniser/filter button will flash red. See pages 12 and 13 for instructions on how to change the filter. Once the filter has been changed, hold the ioniser/filter button for 7 seconds to reset the air purifier.

The air purifier will continue to run with the ioniser/filter button flashing red but the filter **must** be changed or the air purifier may become damaged.

WI-FI CONNECTION VIA THE 'SMART LIFE' APP

The air purifier can be controlled via a smart device using the third-party Smart Life app. Only one mobile device can be paired at a time. If you want to change the mobile device the air purifier is connected with, make sure you remove the connection from the previously connected smart device.

1. Download the 'Smart Life' app.



2. Make sure the air purifier is not in Sleep Mode – it can be in Auto, High or Medium.

3. Hold the timer button for 7 seconds, the air purifier will bleep once, and the Wi-Fi button will start to flash quickly.



4. Open the app and click 'Add Device'.



5. Click 'Small Home Appliances' and then 'Air-Purifier'.

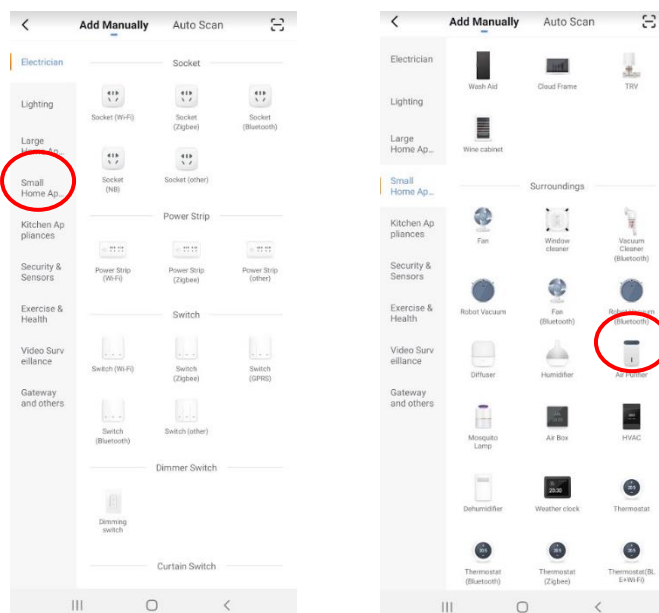

6. Click 'Confirm indicator rapidly blink'.

Confirm indicator rapidly blink

7. Enter your Wi-Fi password and click 'Confirm'.

8. Wait for the app to connect to the air purifier. This may take a few minutes. Place your smart device as close to the air purifier as possible.

9. If the connection fails, click 'Switch Pairing Modes'.

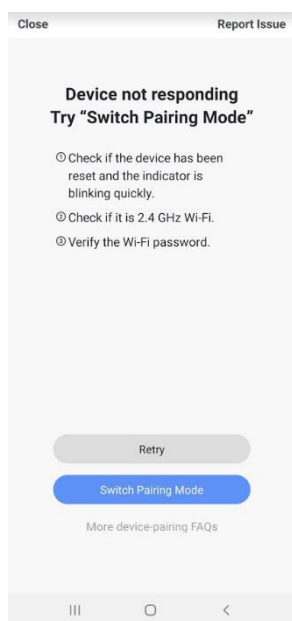

10. Hold the timer button again for 7 seconds. The air purifier will bleep and after a couple of seconds the Wi-Fi button will change to flashing slowly.

11. Scroll to the bottom of the page and click 'Confirm indicator slowly blink'.

Confirm indicator slowly blink

12. Enter your Wi-Fi password and click 'Confirm'.

13. Click 'Go to connect'. The app will take you to the Wi-Fi page on your mobile device.

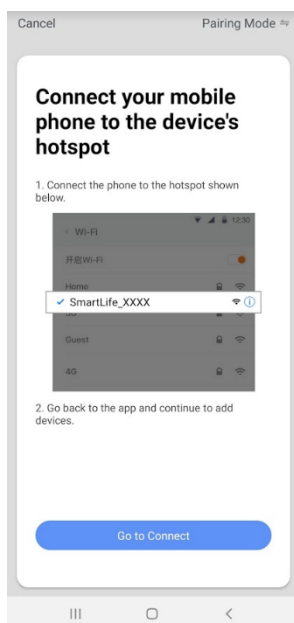

14. Choose the Wi-Fi connection called 'Smart Life' (or something similar, the name will differ depending on the type of mobile device used).

15. Go back to the app and once the connection reaches 100% it is complete.

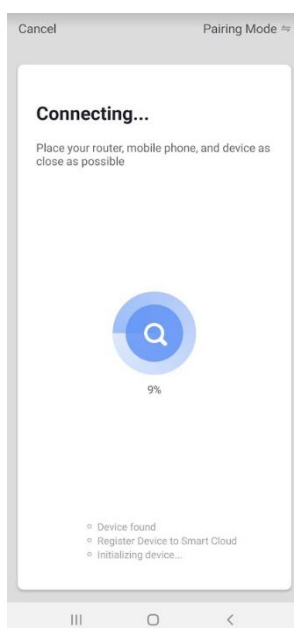

CLEANING AND STORAGE

- Before cleaning the air purifier make sure the power has been turned off and the air purifier is unplugged from the mains.
- The air purifier has one filter which is a combination of the following: the pre-filter, the HEPA filter and the carbon filter.

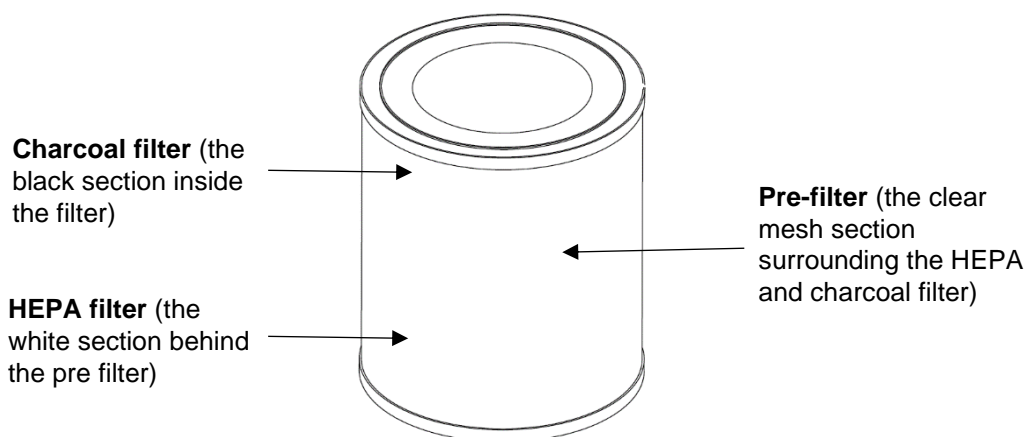

- The pre-filter must be cleaned every two weeks using a soft cloth to brush away any dust or dirt. Do not clean the pre-filter with water or a Hoover.
- The HEPA and charcoal filters cannot be cleaned as they are inside the filter and inaccessible.
- The whole filter must be replaced when the ioniser/filter button flashes red – it will do this after 2200 hours of use or if it detects a build up of dust and dirt on the filters. See page 7 for the location of the Ioniser/Filter button.
- The air purifier will continue to run with the ionizer/filter button flashing red but the filter **must** be changed or the air purifier may become damaged.
- To replace the filter, follow the six steps below:

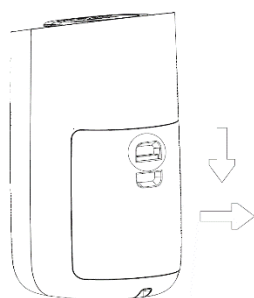

1. Open the filter door by squeezing the button on the door to release.

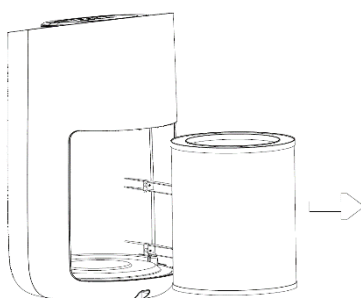

2. Push the filter down and twist it clockwise to remove.

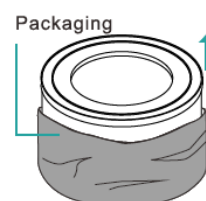

3. Remove the new filter from its packaging.

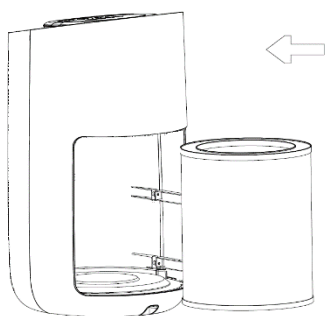

4. Insert the new filter.

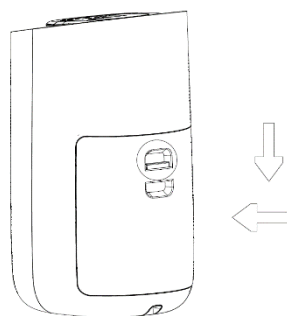

5. Put the filter door back in place – squeeze the button on the door to reinsert.



6. Tap and hold the filter button on the display for 7 seconds to reset the air purifier.

- If the air purifier will not be used for a long period of time clean the filter and store the machine in a dust-free location away from direct sunlight, preferably covered with a sheet of plastic.

SPECIFICATIONS

Room Size	76m ³ for 5 air changes/hour
Noise Level (high/medium/sleep mode)	56/43/25 dB(A)
Air Flow (high/medium/sleep mode)	450m ³ /250m ³ /150m ³
Rated Voltage	220 – 240V / 50Hz
Power Consumption	50W
Dimensions (HWD)	497 x 303 x 270 mm
Nett / Gross Weight	4.6 Kgs / 5.5 Kgs

TROUBLE SHOOTING

TROUBLE	CAUSE	SOLUTION
The ioniser/filter button is flashing red	The filter is dirty and needs replacing	Replace the filter and then hold the ioniser/filter button for 7 seconds to reset the air purifier
The ioniser/filter button is still flashing red after the filter has been replaced	The air purifier needs to be reset	Hold the ioniser/filter button for 7 seconds to reset the air purifier
All the buttons are disabled	Child Lock has been turned on	Hold the light button down for 3 seconds to disable Child Lock
The lights flash on and go off straight away	The air purifier is in sleep mode	Press the mode button and change the mode to Auto, High or Medium
The air purifier is plugged in but there are no lights on the display	The air purifier is in standby mode	Press the power button once – it will run in default mode
The air purifier has turned off without me manually turning it off	The timer was set	Turn the air purifier back on by pressing the power button
The fan speed keeps changing	The air purifier is in auto mode	Press the mode button and change the mode to Sleep, High or Medium
The coloured light is not showing how clean the air is	The light is turned off	Press the light button and choose either soft or standard
There is a weird smell coming from the air purifier	If the air purifier is new, it is normal for it to emit a smell of plastic	The smell will disappear with time
	The pre-filter needs cleaning	See pages 12 and 13 for instructions on how to clean the pre-filter

WARRANTY AND CUSTOMER SERVICE

There is a two-year manufacturer's warranty on your air purifier from the date of purchase. Please register your purchase at <https://meaco.com/warranty-register> - as a thank you, you will be entered into our monthly free prize draw to help support the David Shepard Wildlife Foundation. Registering also allows us to keep you update with any important developments concerning your product.

Within the two-year manufacturer's warranty, all manufacturing defects will be repaired free of charge (excluding damage caused by wear and tear). Filters are not covered under the manufacturer's warranty.

The following applies:

1. Any repairs or replacement of components during the warranty period will not result in an extension of the warranty period.
2. The warranty will expire if any alterations have been made, not genuine components have been fitted or if the air purifier has been repaired by a third party.
3. Components subject to normal wear and tear are not covered by the warranty.
4. The warranty is only valid on presentation of the original, unaltered, and date-stamped purchased receipt.
5. The warranty does not cover damage caused by actions that deviate from those as described in the user's manual or by neglect.
6. The warranty does not cover faults caused by dirt or by third-party products.
7. The warranty does not cover accidental damage.
8. All claims for compensation, including consequential damage, will not be entertained.
9. Using a third-party switching device that turns the humidifier on or off via the mains will invalidate the warranty.

For the full list of the warranty terms and conditions please visit: www.meaco.com/warranty-terms.

To prevent unnecessary expenses, we recommend that you always carefully read the user's manual first. If this does not provide a solution, please call Meaco and we will be happy to help.

This humidifier has been imported into the UK and EU by:

*Meaco (UK) Limited
Meaco House
Parklands
Railton Road
Guildford
GU2 9JX*

*Telephone: 01483 234900
Email: service@meaco.com
Website: www.meaco.com*

Please record, for future reference, your date of purchase and where you bought the air purifier from here.

Date of purchase:

Purchased from www.meaco.com (if not, then please record the supplier's name below).

Suppliers name:

If your air purifier develops a fault at any time, please contact us and we will always try and help you as best we can. Please keep hold of the original box and packaging your unit arrived in just in case we need to collect the humidifier from you for a repair/service in the future.



This marking indicates that this product should not be disposed with other household wastes throughout the UK and EU. To prevent possible harm to the environment or human health from uncontrolled waste disposal, recycle it responsibly to promote the sustainable reuse of material resources. To return your used device, please use the return and collection systems or contact the retailer where the product was purchased. They can take this product for environmental safe recycling.

