



MeacoFan 650 Air Circulator Instruction Manual



MeacoFan 650 Air Circulator

Please read this instruction manual before using the air circulator and keep safe for future reference.

Thank you for choosing Meaco, we really appreciate it.

Safety Information

This air circulator must not be used in rooms under the following conditions: potentially explosive atmosphere, aggressive atmospheres, featuring a high concentration of solvents or an extremely high ratio of dust.



Magnets: The air circulator and the remote control both contain magnets. Please note the following: Pacemakers and defibrillators may be affected by magnets. If this affects you then please do not put the remote control in a pocket and warn anyone who is likely to use the air circulator or the remote that it has a magnet. Credit cards and data cards can also be affected by magnets and should not be placed near to the air circulator or the fan.

Keep Children Away: Do not allow children to play with or around this unit, which could result in injury. Be sure the unit is inaccessible to children when not attended. This appliance is not intended for use by person (including children) with reduced physical, sensory or mental capabilities, or lack of experience and knowledge, unless they have been given supervision or instruction concerning use of the appliance by a person responsible for their safety.

Keep Unit Grounded: Always operate the unit with a grounding plug and a grounded electrical outlet. A grounding plug is an essential safety feature that helps reduce the risk of shock or fire.

Protect Power Cord from Damage: Never operate a unit with a damaged power cord, as this may lead to electrical or fire hazards. If the power supply cord is damaged, it must be replaced by a cord of the same type and amperage rating.

Extension Cords: Extension cords must be grounded and able to deliver the appropriate voltages to the unit.

Handle with Care: Do not drop, throw or crash the air circulator. Rough treatment can damage the components or wiring and create a hazardous condition.

Run on Stable Surface: Always operate the unit on a stable, level surface, for example the floor or a strong counter, so that the air circulator cannot fall and cause injury.

Keep Out of Water: Never operate the unit in pooled or standing water, as this may create a risk of injury from electrical shock. Do not store or operate outdoors. If electrical wiring or components become wet, thoroughly dry them before using the unit. If in doubt do not use the air circulator and consult a qualified electrician or a Meaco approved engineer.

Keep Air Intakes Clear: Do not clog or block the air intakes by placing the air circulator too close to curtains, walls or anything that will restrict the air inlet. This may cause the unit to overheat and result in a fire or electrical hazard.

Keep Electrical Components Dry: Never allow water inside the air circulator's electrical components. If these areas become wet for any reason, thoroughly dry them before using the air circulator. If in doubt, do not use the air circulator and consult a qualified electrician or a Meaco approved engineer.

The operator must make the operating instruction available for the user and make sure that the user does understand the manual.

Power Supply

This power supply changes mains alternating current to touch safe low voltage (DC). The power supply is only designed for indoor use and should not come into contact with water or dust. To prevent overheating the power supply should not be covered when it is in use.

The mains socket should be easily accessible. In the event of operational error, the plug should be immediately removed from the socket. In the event that the mains cable becomes damaged, then the power supply should not be used.

The power supply contains potentially dangerous voltages internally and the cover should not be removed. All service or maintenance work should be carried out by qualified personnel.

If you require assistance, please contact Meaco.

General Advice

- Before putting your air circulator into operation for the first time, the instruction manual should be studied carefully.
- After receiving the air circulator, you should check the unit for any transport damage. In case of damage, you should inform the sender immediately.
- Keep the packaging for the air circulator in a safe place. In order to save space, you can simply cut through the adhesive tape using a knife and fold the cardboard box.

Product Identification

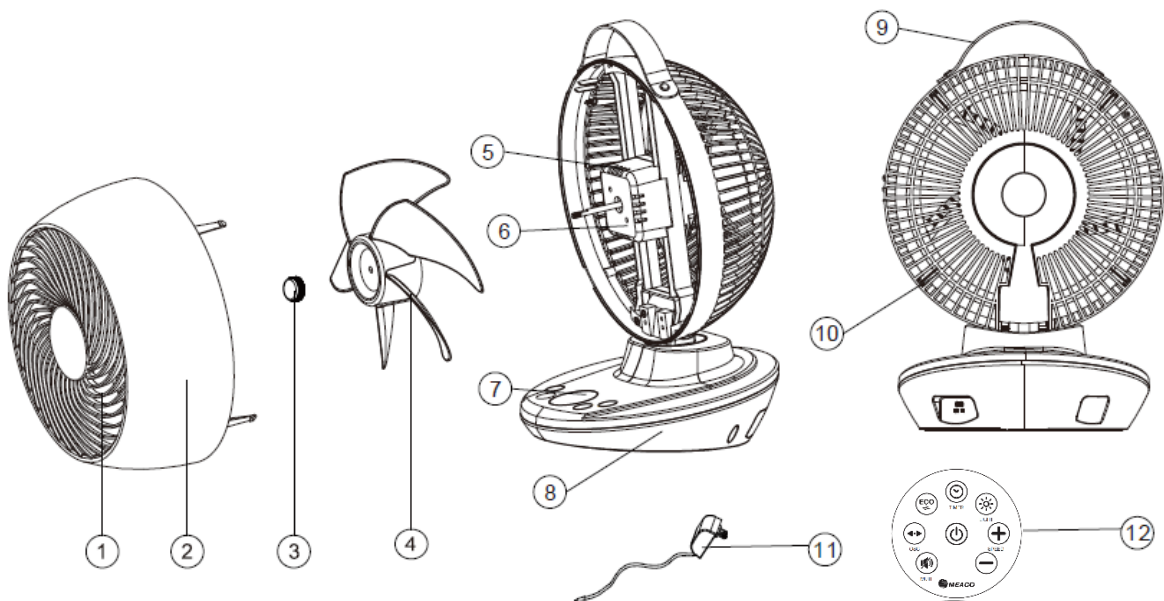

- | | | |
|------------------|-----------------------------|--------------------|
| 1. Front guard | 2. Front shell | 3. Blade nut |
| 4. Fan blades | 5. Motor holder | 6. Fan motor |
| 7. Control panel | 8. Base | 9. Handle |
| 10. Back guard | 11. Cable and mains adapter | 12. Remote control |

**The handle is made from artificial materials and does not contain any animal products.*

***The remote is supplied with a CR2025 DC3V battery. Please remove the tab from the battery before use.*

When you first receive the fan, the fan cable and mains adapter must be connected to the base of the fan. In order to do this, see the diagram below. The cable can be inserted into the fan either way up. Do not try and force the connection.

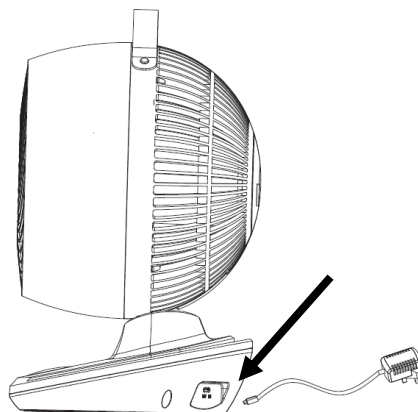

Control Panel



Please note all the buttons are touch sensitive and bleep when pressed. If you do not want the buttons to bleep when pressed, use the Mute Button on the remote control (see page 5).

Power



When plugged in the fan will bleep once and display the room temperature on the display, this is standby mode. To turn the fan on press the ON/OFF button. The fan will bleep and start to operate. To turn the fan off press the ON/OFF button again, you will hear a longer bleep and the fan will slow down and stop.

Speed



Press the speed button to adjust the air flow fan speed. There are 12 fan speeds available. As long as the fan remains plugged in the fan will remember the last fan speed used. The speed can be adjusted on the control panel or via the remote control.

Oscillation (OSC)



Press the oscillation button to start and stop the sideways oscillation left and right. Press the button once to turn the oscillation on and press the button again to stop the motion, in doing so you can fix the direction of the fan.

The up and down angle can be fixed manually by hand, place one hand on the base and one hand on the top of the fan, gently move the head up or down as required.

Timer



When the fan is in standby mode use the timer button to set an interval, in 30-minute segments, between 1 and 6 hours after which the fan will turn ON. Once you have reached the desired number of hours on the display the number will flash four times and then set.

When the fan is turned on and running, use the timer button to set an interval, in 30-minute segments, between 1 and 6 hours after which the fan will turn OFF. Once you have reached the desired number of hours on the display the number will flash four times and then set.

Remote Control

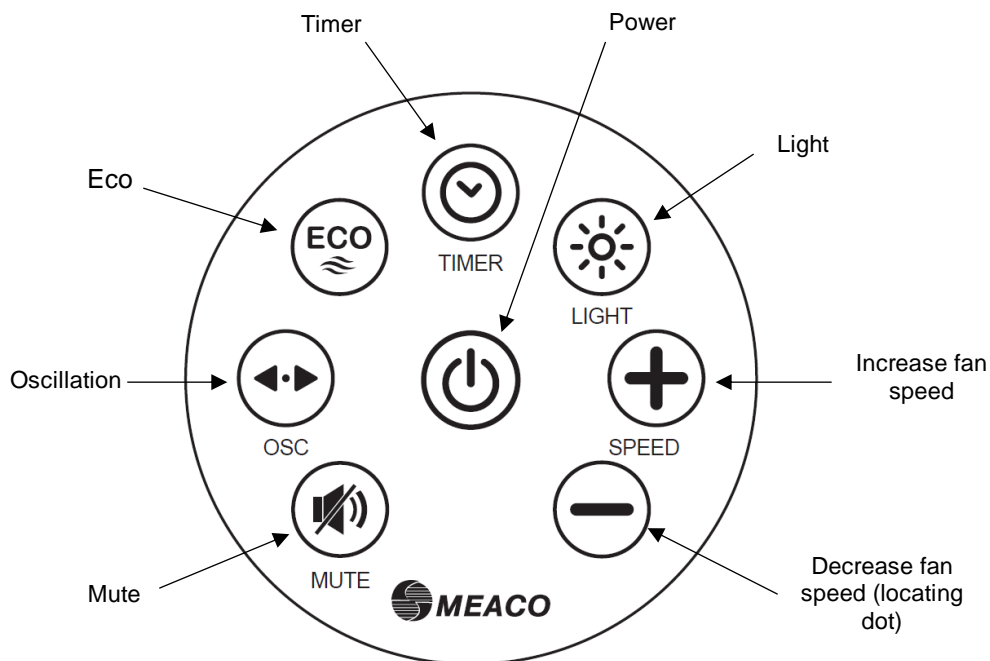

The following functions are only available via the remote-control. All other buttons on the remote-control work in the same way as the control panel (see page 4). The remote control has a range of approximately three metres. Before using the remote control, please remove the plastic tab.

Mute

Press the mute button to stop the fan from beeping when a button is pressed. To turn the beeps back on, press the mute button again.

Light

Press the light button to turn the lights on the display ON/OFF.

Eco

Press the ECO button to turn ECO mode ON/OFF. In ECO mode the fan speed will automatically change as per the table on the following page. AI (Artificial Intelligence) will appear on the display.

Increase fan speed

Press the increase fan speed button to increase the air flow fan speed between 1 and 12.

Decrease fan speed

Press the decrease fan speed button to decrease the air flow fan speed between 12 and 1.



ECO Mode

Room temperature	Fan speed
<23°C	2
23 to 25°C	4
25 to 27°C	6
27 to 29°C	8
29 to 31°C	9
31 to 33°C	10
>33°C	12

Electrical Connections & Operating Conditions

This air circulator was designed to operate in a 220V-240V/50Hz electrical installation. Make sure that the electric sockets are connected to earth and that all safety precautions are taken.

This air circulator can be operated within an ambient temperature range from +5°C to +40°C and with a non-condensing relative humidity.

Specifications

Operating conditions	+5°C / +40°C
Humidity operating range	Non-condensing
Fan motor type	DC
Maximum air flow	650 cubic metres per hour
*Maximum air velocity (c)	5m/sec
*Rated voltage and frequency	220-240V / 50Hz
Power consumption	3.5 to 12 watts
*Standby power consumption (PSB)	0.3 watts
Oscillation swing angles	40° up and 5° down manually 37° left and 33° right automatically
*Fan sound power level (LWA)	20 to 60dB(A)
*Service value (SV)	0.78 (m ³ /min)/W
*Fan power input (P)	12 watts
*Maximum fan flow rate (F)	9.42m ³ /min
Dimensions (HWD)	350 x 255 x 235mm
Nett / Gross weight	1.6 / 3.0 Kgs

Measurement Standard for Service Value (all items): EN 55014:2017

Cleaning & Maintenance

Always turn the fan off and unplug it from the socket before cleaning.

Use a soft dry cloth to clean the external and internal parts of the fan. Do not allow the fan to get wet. In order to access the fan blades, follow the steps below:

1. Using a screwdriver, unscrew the small screw at the top back of the fan. It is located directly below the right end of the handle.

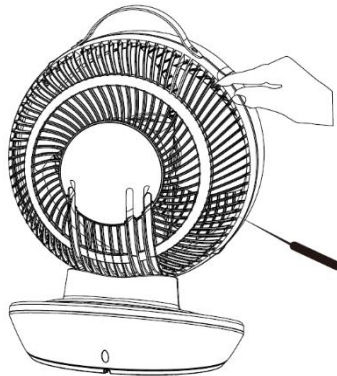

2. Squeeze four locks to pull away the front guard. At the front of the fan blades there is a locking cap – unscrew the cap in a clockwise motion to remove the fan blades.

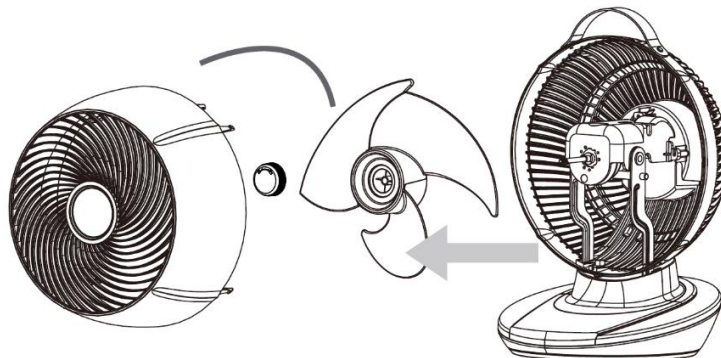

3. Clean the fan blades and the internal part of the fan using a soft dry cloth. Reverse the procedure to put the fan back together. Make sure the locking cap is tightened securely.

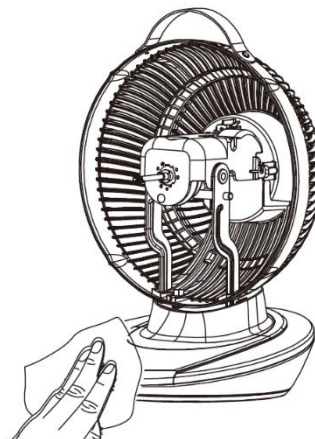

Replacing the battery

If the remote control fails to work whilst close to the fan, please replace the battery. The battery is a CR2025 and can be replaced following the steps in the diagram below.

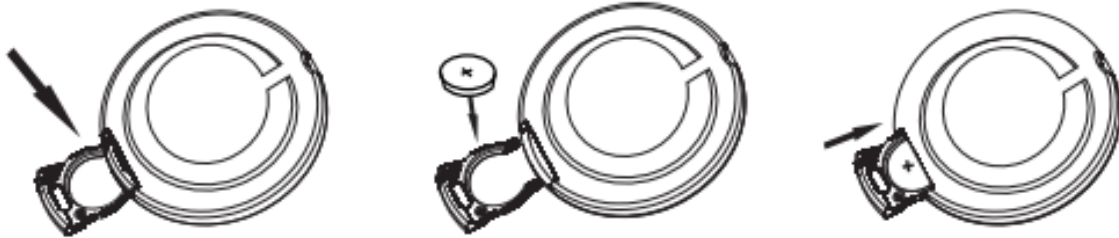

Storage

When storing the fan use the cable compartment at the back of the fan to store the mains cable. The cable compartment cover may be stiff to remove at first – use the small lever at the top to pull it away from the fan.

We recommend storing the fan in its plastic bag or original box to protect the fan from dust. Alternatively, a customised bag can be purchased from www.meaco.com.

Remember the fan can also be used in winter to help distribute warm air more effectively within a room.

Trouble Shooting

Trouble	Cause	Solution
The display shows '00' or '99'	There is a problem with the circuit	Please contact Meaco
The fan does not oscillate	The MPCB needs resetting	Unplug the fan from the mains for 40 minutes
Increased noise level	The fan blades are dirty	Clean the fan blades (see page 8)
	The fan blades or fan motor is loose	Tighten the locking cap (see page 8)
	There is a fault with the fan motor	Please contact Meaco
The motor can be heard on the lower fan speeds	As the fan is so quiet it is expected to hear the motor on the lower fan speeds. As the fan speed increases, the noise of the motor will reduce	This is not a fault and is normal
The fan does not start up	The fan is in standby mode	Press the power button again
The fan is making a clicking noise	The fan needs lubricating	Run the fan on the highest fan speed for 4 hours
The remote does not work	The battery needs replacing	Replace the battery (see page 9)
	The remote is being used more than 3m away from the fan	Use the remote closer to the fan and make sure it is pointing directly at the fan base
AI appears on the display	This is a not a fault, the fan is in ECO mode	Press the ECO button to turn ECO mode off

Warranty & Customer Service

There is a two-year manufacturer's warranty on your air circulator from the date of purchase. Please register your purchase at <https://meaco.com/warranty-register> - as a thank you, you will be entered into our monthly free prize draw to help support the David Shepherd Wildlife Foundation. Registering also allows us to keep you update with any important developments concerning your product.

Within the two-year manufacturer's warranty, all manufacturing defects will be repaired free of charge.

The following applies:

1. Any repairs or replacement of components during the warranty period will not result in an extension of the warranty period.
2. The warranty will expire if any alterations have been made, not genuine components have been fitted or if the air circulator has been repaired by a third party.
3. Components subject to normal wear and tear are not covered by the warranty.
4. The warranty is only valid on presentation of the original, unaltered, and date-stamped purchased receipt.
5. The warranty does not cover damage caused by actions that deviate from those as described in the user's manual or by neglect.
6. The warranty does not cover faults caused by dirt or by third-party products.
7. The warranty does not cover accidental damage.
8. All claims for compensation, including consequential damage, will not be entertained.
9. Using a third-party switching device that turns the air circulator on or off via the mains will invalidate the warranty.

For the full list of the warranty terms and conditions please visit: www.meaco.com/warranty-terms.

To prevent unnecessary expenses, we recommend that you always carefully read the user's manual first. If this does not provide a solution, please call Meaco and we will be happy to help.

This air circulator has been imported into the UK by:

*Meaco (UK) Limited
Meaco House, Parklands
Railton Road, Guildford
GU2 9JX*

*Telephone: 01483 234900
Email: customerservice@meaco.com
Website: www.meaco.com*

Please record, for future reference, your date of purchase and where you bought the air circulator from here:

Date of purchase:

Purchased from www.meaco.com (if not, then please record the supplier's name below).

Suppliers name:

If your air circulator develops a fault at any time, please contact us and we will always try and help you as best we can. Please keep hold of the original box and packaging your unit arrived in.

This marking indicates that this product should not be disposed with other household wastes throughout the UK. To prevent possible harm to the environment or human health from uncontrolled waste disposal, recycle it responsibly to promote the sustainable reuse of material resources. To return your used device, please use the return and collection systems or contact the retailer where the product was purchased. They can take this product for environmental safe recycling.

