

CAUTION: PROTECT BALLS AND RACES FROM SAWDUST, DIRT, PAINT, ETC. SHOULD BEARING BECOME "ROUGH" FROM DIRTY RACES, FLUSH THOROUGHLY WITH HOT SOAPY WATER, RINSE, OVEN DRY AND RE-OIL.

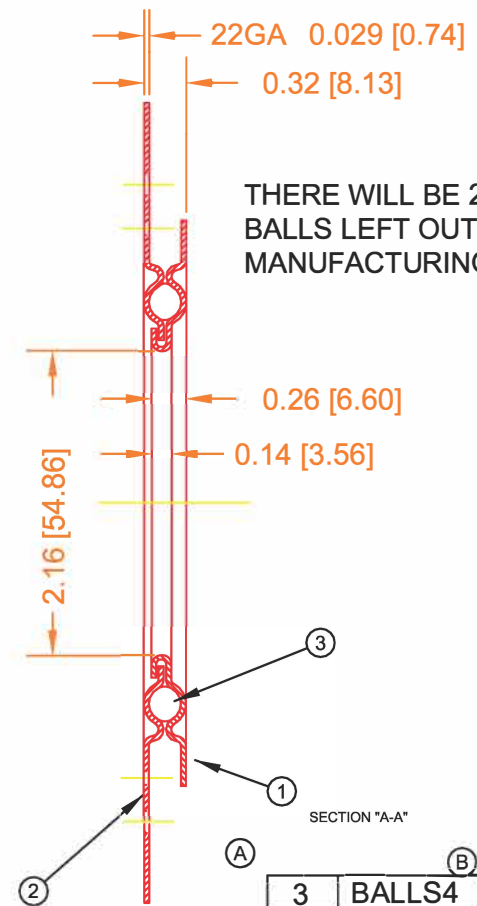
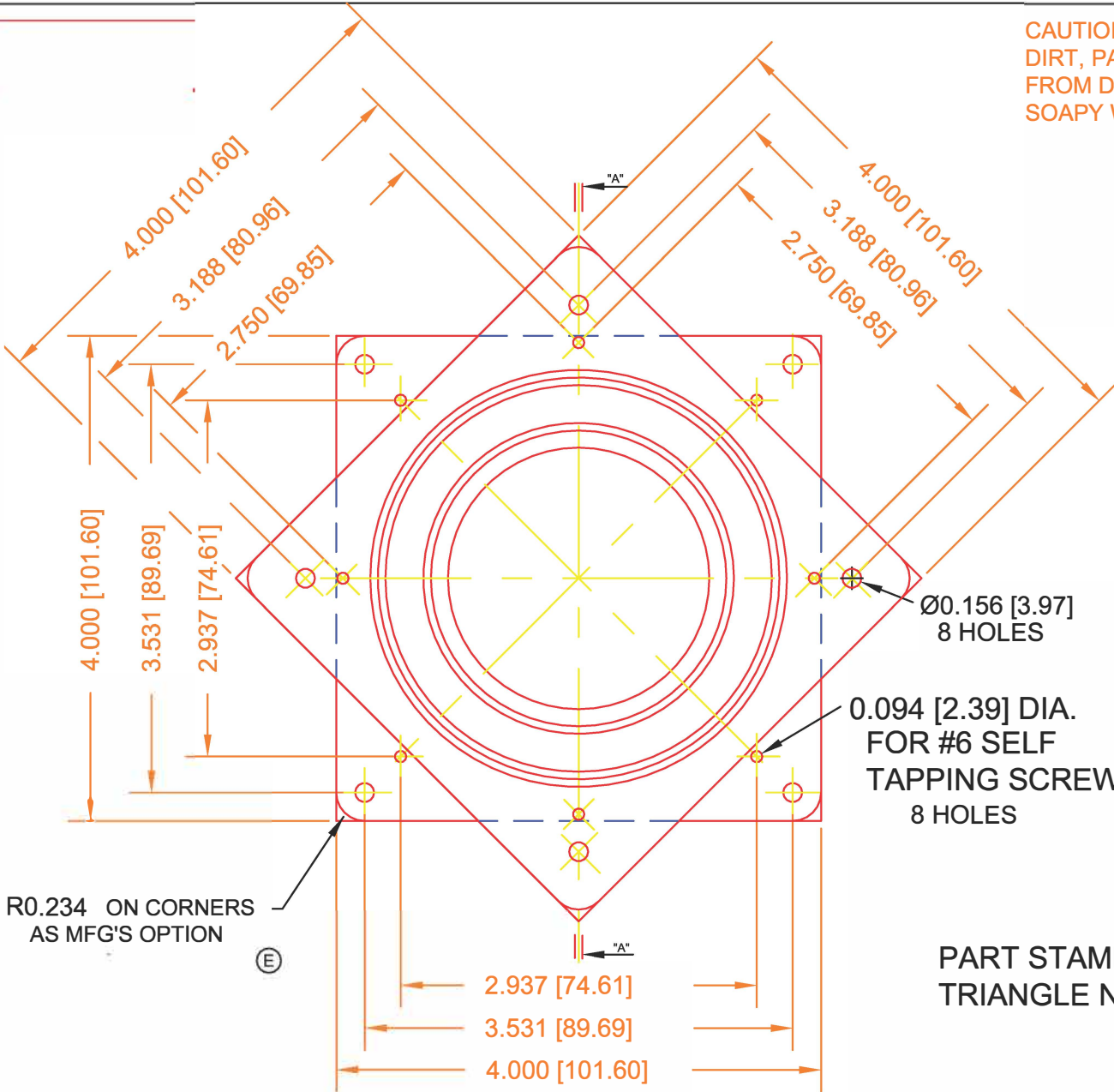

THERE WILL BE 2 TO 4 BALLS LEFT OUT DUE TO MANUFACTURING PROCESS.

PART STAMPED WITH TRIANGLE NAME STAMP

3	BALLS4	BALL	1
2	2823	PLAIN RACE	1
1	9486	STAMPING	1
DET	PART NUMBER	DESCRIPTION	AMT
<b>B</b> TRIANGLE MANUFACTURING CO.			

FIT		////	
PLATING		ELECTRO-GALV	
MATERIAL		SEE DETAILS	
ALL DIMS ±.020 UNLESS SPECIFIED			
NAME		4" LAZY SUSAN BEARING	
USED IN		4C SERIES	
DATE		11-2659	PART NO.
DRAWN		LML	4C
CHECKED		MJK	
SCALE		1 / 1	

CHANGE LEVEL
H   09-05-12