

Weld-on-Hubs

Taper Bore Weld-on-Hubs are made out of steel, drilled, tapped and taper bored to receive standard Taper Bushes. The extended flange provides a convenient means of welding hubs into fan rotors, steel pulleys, plate sprockets, impellers, agitators and many other devices which must be firmly fastened to the shaft.

Challenge Weld-on-Hubs are manufactured to complement the Taper Bush range and include W, WH and WM Taper Bore Hubs. All are manufactured to world standards using low carbon steel.

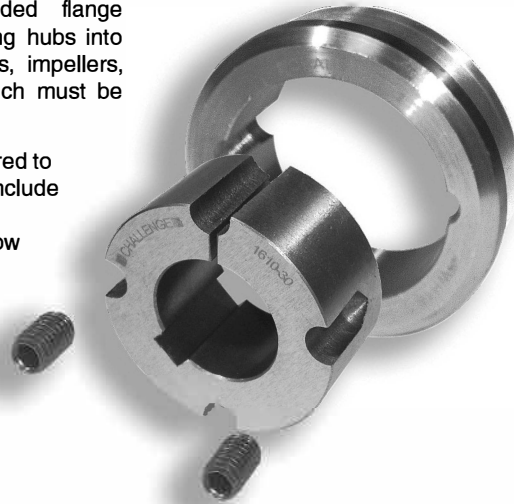

Typical Assembly

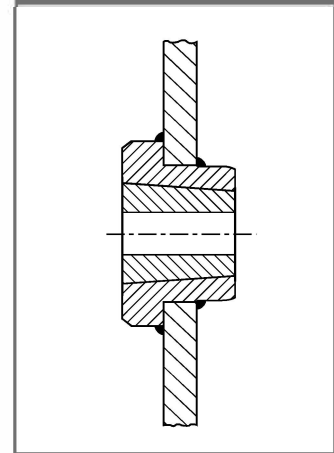

W Weld-on-Hubs

Hub Reference	Bush Size	A	B	C	D	E	F	F1	X
W12	1215	73	64	63	38	16	10	-	-
W16	1615	83	73	72	38	16	10	-	-
W25	2517	127	111	110	44	19	13	-	-
WG30	3030	150	133	133	76	25	19	23	23
WG35	3535	184	159	158	89	32	25	30	30
WG40	4040	225	197	196	102	32	32	34	34
WG45	4545	254	222	221	114	38	38	38	38
WG50	5050	276	241	240	127	38	38	42	42
WG60	6050	375	343	342	127	38	38	42	42
WG70	7060	425	375	374	153	51	51	51	51
WG80	8065	445	394	393	165	51	51	55	55
WG100	10085	559	495	494	216	51	51	72	72

"G" notation represents welding relief.

W & WH Weld-on-Hub

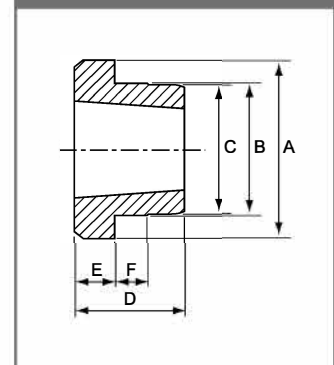

WH Weld-on-Hubs

Hub Reference	Bush Size	A	B	C	D	E	F	F1	X
WH12	1210	70	65	64.5	25	9	10	-	-
WH16-1	1610	80	75	74.5	25	9	10	-	-
WH20	2012	95	90	89.5	32	12	12	-	-
WH25	2517	115	110	109.5	44	19	15	-	-
WHG30-2	3020	145	140	139.5	50	20	15	17	17
WHG35	3525	190	180	179.5	65	25	25	22	22
WHG40-1	4030	200	190	189.0	76	32	30	25	25
WHG40-2	4040	200	190	189.5	101	32	30	34	34
WHG45-1	4535	210	200	199.5	89	40	30	30	30
WHG45-2	4545	210	200	199.5	114	40	30	38	38
WHG50-1	5040	230	220	219.5	102	40	35	34	34
WHG50-2	5050	230	220	219.5	127	40	35	42	42

"G" notation represents welding relief.

WG & WHG Weld-on-Hub

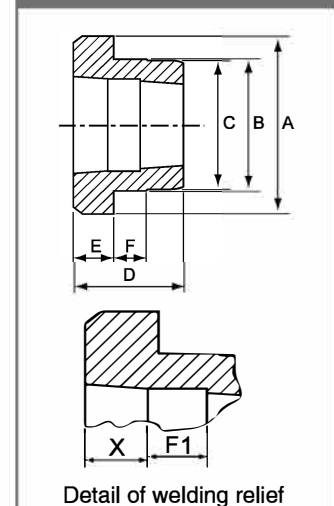

Shaft Fixings

Weld-on-Hubs

WM Weld-on-Hubs

Hub Reference	Bush Size	A	B	C	D	E	F	F1	X
WMG12	1210	70	60	58	26	9	10	9	9
WMG16-1	1610	83	70	68	26	9	10	9	9
WMG16-2	1615	83	70	68	38	16	11	13	13
WMG20	2012	95	90	88	32	12	12	11	11
WMG25	2517	127	110	108	44	19	13	15	15
WMG30-2	3020	152	130	125	50	20	15	17	17
WMG30-3	3030	152	130	125	76	25	19	25	25
WMG35	3535	184	155	151	89	32	25	30	30
WMG40	4040	225	195	187	102	32	32	34	34
WMG45	4545	254	220	213	114	38	38	38	38
WMG50	5050	276	242	228	127	38	38	42	42

"G" notation represents welding relief.

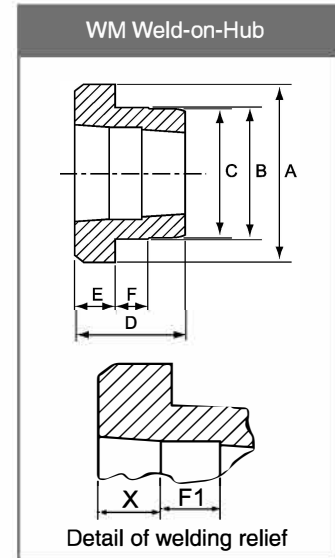

WELD-ON-HUB WELDING INSTRUCTIONS

Challenge Weld-on-Hubs are made from steel, drilled, tapped and taper bored to receive standard Taper Bushes. The external flange provides a convenient means of welding hubs into fan rotors, steel pulleys, plate sprockets, impellers and many other devices which need to be firmly fastened to a shaft.

It is recommended that a continuous 45° mitre weld be used, working on the larger hub diameter section only. To ensure accuracy in the welded assembly it is essential to apply only sufficient weld to achieve sufficient strength. Excess weld should not be necessary for normal use which, due to greater heat input, gives a higher risk of distortion. The Table A shows the recommended continuous fillet weld requirements for each hub size.

For electric arc welding, low hydrogen electrodes are recommended.

Please note: the "G" reference on Challenge welding-on-hubs represents a welding relief inside the bore to help avoid problems with distortion caused by welding hook.
(see F1)

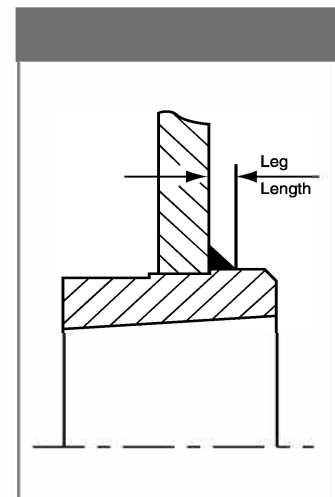

Hub Size.	Leg Length mm
WH12	4
WH16	4
WH20	5
WH25	5
WH30	6
WH35	6
WH40	8
WH45	8
WH50	10

Table A