

# Goldair™



## Operating Instructions

### 120cm Ceiling Fan



Model: GCCF165

# General Care and Safety Guide

**Thank you for choosing this Goldair product. This Goldair appliance has been designed and manufactured to high standards of engineering and with proper use and care, as described in this leaflet, will give you years of useful service. Please read these instructions carefully and keep them for future reference.**

1. This appliance is not intended for use by persons (including children) with reduced physical, sensory or mental capabilities, or lack of experience and knowledge, unless they have been given supervision or instruction concerning use of the appliance by a person responsible for their safety.
2. Children should be supervised to ensure that they do not play with the appliance.
3. If the supply cord is damaged, it must be replaced by the manufacturer, its service agent or similarly qualified persons in order to avoid a hazard.
4. Ensure that the fan is switched off from the supply mains before removing the guard.
5. Use only the voltage specified on the rating plate of the appliance.
6. Keep all objects at least 1 Metre from the front, sides and rear of the appliance
7. This appliance is intended for household use only and not for commercial or industrial use.
8. Use this appliance only as described in this manual. Any other use is not recommended by the manufacturer and may cause fire, electric shock or injury.
9. The common cause of overheating is deposits of dust or fluff in the appliance. Ensure these deposits are removed regularly by unplugging the appliance and vacuum cleaning the air vents and grills.
10. Always unplug appliance when not in use.
11. When the appliance has been unpacked, check it for transport damage and ensure all parts have been delivered. If parts are missing or the appliance has been damaged, contact the Goldair Customer Services Team.
12. If your appliance does not work, or is not working properly, contact the place of purchase. Repair work on the appliance by unqualified persons can cause serious risk to the user.
13. Ensure hands are dry before handling the plug or the main unit.
14. Carry out regular checks of the supply cord to ensure no damage is evident.
15. Ensure that the cord is fully extended (not coiled) while in use.
16. Avoid contact with the moving parts. Keep hands, hair, clothing, away from blade of the fan during operation to reduce the risk of injury to person and/or damage to the unit.
17. Switch off and use handles provided when moving.
18. It is recommended that this fan is plugged directly into the wall socket.
19. A correctly specified, undamaged extension cord may be used with this fan provided it is used in a safe manner.

# General Care and Safety Guide

20. Never place appliance close to radiant heat source.
21. Never operate in areas where petrol, paint or other flammable liquids are used or stored.
22. Never use the appliance to dry clothes.
23. Never insert or allow foreign objects to enter any ventilation or exhaust opening, as this may cause an electric shock, fire or damage to the appliance.
24. Never use abrasive cleaning products on this appliance. Clean with a damp cloth (not wet) rinsed in hot soapy water only. Always remove plug from the mains supply before cleaning.
25. Never connect the appliance to mains supply until completely assembled and adjusted.
26. Never remove plug from power socket until the appliance has been switched off.
27. Never remove plug from power socket by pulling cord – always grip plug.
28. Never twist, kink or wrap the cord around the appliance, as this may cause the insulation to weaken and split. Always ensure that all cord has been removed from any cord storage area and is unrolled before use.
29. Never use this appliance in the immediate surrounds of a bath, a shower, or a swimming pool or other liquids. The appliance must not be immersed in any liquids.
30. Due to the risk of injury, never use this appliance for any purpose other than its intended use. This appliance is intended for use in household and similar applications such as staff kitchen areas in shops, offices and other working environments; farm houses, by clients in hotels, motels, bed and breakfast type environments and other residential type environments
31. Never use this appliance outdoors.
32. Never operate the appliance with a damaged cord or plug, after it malfunctions, or if it has been damaged in any manner. Have the appliance checked and repaired by a qualified electrician if repair is necessary.
33. Never place the unit in wardrobes or other enclosed spaces as this may cause fire hazards.

<b>Goldair</b>	<b>T</b>
Model No: GCCF165	
Supply: 220-240VAC 50Hz	
Wattage: 75W	
Approval No: GMA-514021-EA	
MADE IN CHINA	
QC Passed: PO#-WWYY	
<b>CUSTOMER SUPPORT</b>	
<b>NEW ZEALAND PH: 0800 232 633</b>	
<b>AUSTRALIA PH: 1300 465 324</b>	

# Components

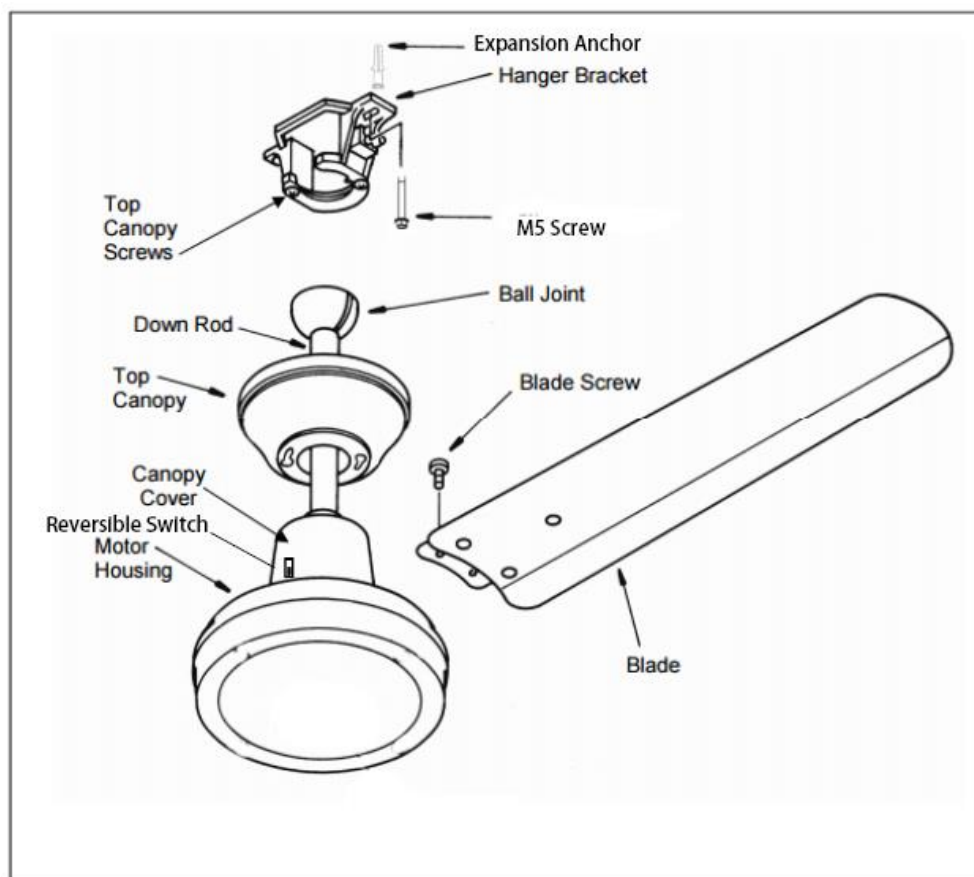

Part	Qty	Part	Qty	Part	Qty
Hanger Bracket	1	Down Rod (21mm Diameter)	1	Blade Screws	6
M5 Screws	2	Down Rod Pin	1	Blade Washers	6
Top Canopy	1	Down Rod Short Screw	2	Reversible Switch	1
Top Canopy Screws	2	Canopy Cover	1	HPI Wall Controller	1
Ball Joint	1	Motor Housing	1		
Ball Joint Screw	1	Expansion Anchor	2		
Ball Joint Pin	1	Blades	3		

# Installing your Fan

NOTE: Improperly installed ceiling fans can be dangerous and expensive to repair and will void the warranty. This fan is designed for indoor use only. Do not mount in positions where fan is subject to water or moisture.

**The fan must be installed so that the blades are more than 2.1 metres above the floor.**

**WARNING** keep all objects at least 500mm from the sides of the appliance.

Note to the Installer

1. Please retain this instruction leaflet and give it to the owner for their future reference.
2. Means for disconnection must be incorporated in the fixed wiring in accordance with the wiring rules.
3. All wiring must comply with the requirements of AS/NZS 3000.
4. Use the AS/NZS Certified wall switch/controller supplied or an AS/NZS Certified wall switch/controller supplied by an authorised electrician.
5. The fan blades supplied for this fan are matched to minimise wobble.
6. If installing more than one fan do not mix blade sets.
7. This appliance is not intended for use by persons (including children) with reduced physical, sensory or mental capabilities, or lack of experience and knowledge, unless they have been given supervision or instruction concerning use of the appliance by a person responsible for their safety.

Installation

1. Choose a location for the fan which will ensure adequate clearance from all objects and walls and that the fan blades will be more than 2.1 metres from the floor.
2. At the selected mounting position, check whether there is a ceiling joist to which the fan can be secured. If there is no suitable supporting member, install a 50 x 100mm brace between ceiling joists.
3. Secure the Hanger bracket with 2 screws to the ceiling

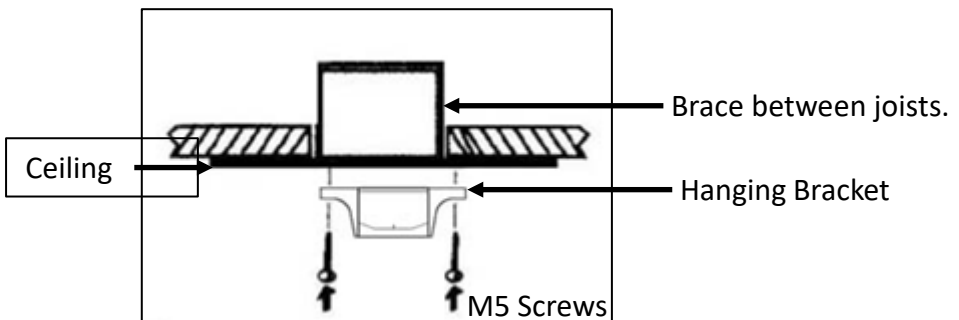

## Angled Ceiling Installation

This fan hanging system supports a maximum 15 degree angled ceiling installation.

# Installing your Fan

This fan is to be installed by authorised electrician. Wiring diagram below for reference.  
The fan must be earthed.

Wiring Diagram:

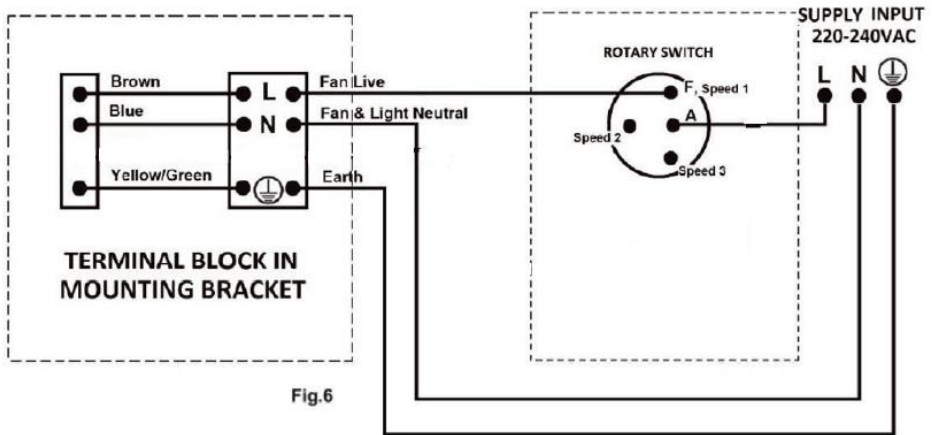
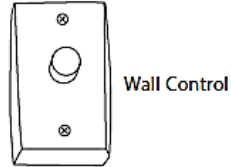
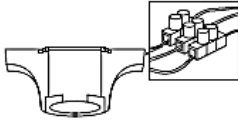

# Installing your Fan

Attach the blades to the motor housing using 2 blade screws per blade.



# Installing your Fan

Carefully lift the fan assembly onto the hanging bracket. Rotate fan until the notch on down rod ball (1) engages the ridge in the hanging bracket (2). This will allow for hands free wiring. With the hanging bracket holding the fan assembly, make sure the connector is properly in place.

Wires connections on the terminal Brown wire --- L; Blue wire --- N; Green/Yellow --- 

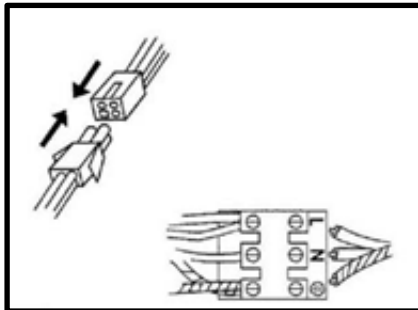
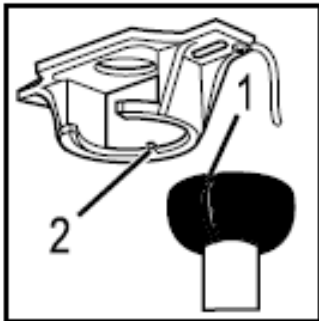

Hanging bracket holding the fan assembly



Make sure the electrical connector is properly in place.

Tighten the lower canopy set screws. Ensure that they are tightened against the down rod to ensure good electrical and mechanical fixing of the lower canopy to the down rod.

Fit the controller. The controller will fit standard wall plate mountings. Wire the controller in accordance with the wiring diagram. Fit to wall. Fit screw caps.

Check all wiring, switch power on at switchboard, check operation.

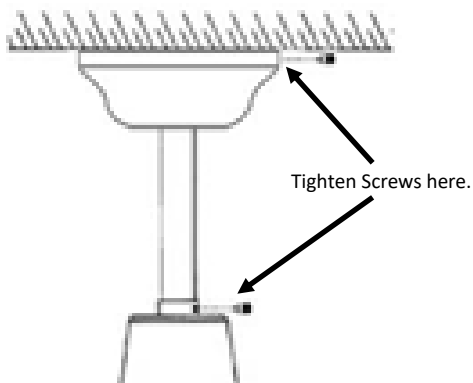



# Operating Instructions

The fan is operated from the wall mounted control switch. It has 3 speed positions and an off position. Turn the knob to the desired speed position to activate the fan and to off to stop it.



## Summer/Winter Operation

This fan incorporates a reversing switch. The switch is located on the side of the lower canopy, just above the motor and blades. With the switch set to the upper position (marked "S" or Summer) air flow is directed downward. This is best for cooling in summer. With the switch set to the lower position (marked "W" or Winter) air flow is directed upwards. This is best for winter operation, and can assist in moving heated air around the room.



# Cleaning and Maintenance

## Care and Cleaning

Periodic cleaning of your new ceiling fan is the only maintenance that is needed. Use a soft brush or lint free cloth to avoid scratching the finish.

- Do not use water when cleaning your ceiling fan, it could damage the motor or the blades and create the possibility of an electrical shock.
- Motor has permanently lubricated ball bearings. No need to oil.
- This fan is not intended for use by young children or infirm persons without supervision.
- Do not allow young children to play with the fan.

## Wobble

- Ceiling fans tend to move during operation due to the fact that they are not generally rigidly mounted - if they were, they could generate excessive ceiling vibration and stress on their mountings.
- Movement of a couple of centimetres is quite OK and does not suggest the fan will fall down.
- Ceiling fans are mounted very securely on steel brackets with rubber cushioning or with ball joints to allow free movement.
- Please note that all ceiling fans are not the same, even in the same model - some may move more or less than others.

The following procedures should eliminate any wobble. Check for wobble after each step. It is impossible to eliminate wobble completely.

- a. Check that all blade brackets are tightened securely.
- b. Most wobble problems result from inconsistent blade level. To check blade level, measure the distance from each blade tip to the ceiling. If measurements are inconsistent, adjustments of brackets will be required.
- c. Wobble problem could also result from deviations in distance from blade to blade. To check blade separation, measure the distance from blade tip to blade tip. Should measurements vary, loosen screws connecting blades and brackets (one at a time) then shift blade to proper position and re-tighten screws.

# Cleaning and Maintenance

## Normal Wear and Tear

Threaded components working slightly loose or blade carriers even slightly bent due to vigorous cleaning or bumping can cause extra wobble and noise. This is not covered under warranty - but a little care and maintenance can reduce or prevent this problem.

## Bumps-in-the-night

This is the biggest cause for service calls which are outside the manufacturer's warranty. If a fan has a fault, it will be noticeable at all times. Naturally when everything is quiet at night, you will be more inclined to hear small noises which may not be noticeable at other times. Even slight power fluctuations, and mains frequency signals superimposed in you electricity supply for off-peak hot water control may cause a change in fan motor noise. This is normal.

## Trouble Shooting

TROUBLE	PROBLEM CAUSE	SUGGESTED REMEDY
Fan will not start	a. Fuse or circuit breaker blown b. Loose power line connections to the fan. c. Reversing switch (where applicable) neither up or down. d. Speed controller not in correct position	a. Check main and branch circuit fuses or circuit breakers. b. Check line wire connections to fan. c. Push switch either fully up or down. d. Check speed controller's position.
Fan wobbles	a. Fan blades not horizontal to ceiling b. Blade screws are loose	a. Measure from ceiling to tip of blades, then rotate fan so all blades are checked for equal height from ceiling. (Note: adjustments may be made by slight pressure up or down on blade holders). Make sure all screws are securely fastened
Fan sounds noisy	a. Light kit glassware loose or rattling b. Incorrect bulb(s) being used in light kit. c. Loose fan blade screws d. Ceiling fan not secured against ceiling	a. Glass fixings should be finger tight. b. Check suggested bulb(s) in light kit c. Re-tighten all screws on fan blades but never over-tighten d. Re-tighten all screws in the hanging bracket or plate. e. Change the controller to the one supplied. Re-tighten the screws in the upper side of the fan motor body.
Mechanical Noise		a. Allow for at least 8 hours settling-in period.

## PROOF OF PURCHASE

To receive warranty retain receipt as proof of purchase. (Refer to back of booklet).

# Goldair™

## SUPPORT AND TECHNICAL ADVICE

**Goldair – New Zealand**  
 Monday – Friday 8am-5pm  
 Phone +64 (0)9 917 4000  
 Phone 0800 232 633  
 info@cdb.co.nz

**Goldair – Australia**  
 Monday – Friday 8am-5pm  
 Phone +61 (0)3 9365 5100  
 Phone 1300 465 324  
 info@cdbgoldair.com.au



## One Year Warranty

Thank you for purchasing this Goldair product. Your product is warranted against faults and manufacture when used in normal domestic use for a period of **one year**. In non-domestic use Goldair limits the voluntary warranty to **three months**.

Goldair undertake to repair or replace this product at no charge if found to be defective due to a manufacturing fault during the warranty period.

This warranty excludes damage caused by misuse, neglect, shipping accident, incorrect installation, or work carried out by anyone other than a qualified electrical service technician.

PLEASE KEEP YOUR RECEIPT AS THIS WILL HELP VERIFY YOUR WARRANTY.

The benefits to you given by this warranty are in addition to other rights and remedies available to you under a law in relation to the goods or services to which this warranty relates.

In Australia, our goods come with guarantees that cannot be excluded under the Australian Consumer Law. You are entitled to a replacement or refund for a major failure and compensation for any other reasonably foreseeable loss or damage. You are also entitled to have the goods repaired or replaced if the goods fail to be of acceptable quality and the failure does not amount to a major failure.

In New Zealand this warranty is additional to the conditions and guarantees of the Consumers Guarantee Act (1993).

### Goldair – New Zealand

CDB Goldair  
PO Box 100-707  
N.S.M.C  
Auckland , 0745

Phone +64 (0)9 917 4000  
Phone 0800 232 633  
[www.goldair.co.nz](http://www.goldair.co.nz)

### Goldair – Australia

CDB Goldair Australia Pty  
PO Box 574  
South Morang  
Victoria, 3752

Phone +61 (0)3 9365 5100  
Phone 1300 GOLDAIR (1300 465 324)  
[www.goldair.com.au](http://www.goldair.com.au)

**Goldair One Year Warranty** (IMPORTANT: Please complete and retain this warranty card)

Name \_\_\_\_\_

Address \_\_\_\_\_

Place Of Purchase \_\_\_\_\_ Date of Purchase \_\_\_\_\_

Name Of Product \_\_\_\_\_ Model Number \_\_\_\_\_

Attach a copy of the purchase receipt to this warranty card

Due to continual design improvements, the product illustrated in this User Manual may differ slightly from the actual product.

# Goldair™



CDB  Goldair™

New Zealand  
PO Box 100707,  
North Shore Mail Centre,  
Auckland, 0745  
[www.goldair.co.nz](http://www.goldair.co.nz)

Australia  
PO Box 574,  
South Morang,  
Victoria, 3752  
[www.goldair.com.au](http://www.goldair.com.au)